



Chipsmall Limited consists of a professional team with an average of over 10 year of expertise in the distribution of electronic components. Based in Hongkong, we have already established firm and mutual-benefit business relationships with customers from,Europe,America and south Asia,supplying obsolete and hard-to-find components to meet their specific needs.

With the principle of “Quality Parts,Customers Priority,Honest Operation,and Considerate Service”,our business mainly focus on the distribution of electronic components. Line cards we deal with include Microchip,ALPS,ROHM,Xilinx,Pulse,ON,Everlight and Freescale. Main products comprise IC,Modules,Potentiometer,IC Socket,Relay,Connector.Our parts cover such applications as commercial,industrial, and automotives areas.

We are looking forward to setting up business relationship with you and hope to provide you with the best service and solution. Let us make a better world for our industry!



Contact us

Tel: +86-755-8981 8866 Fax: +86-755-8427 6832

Email & Skype: info@chipsmall.com Web: www.chipsmall.com

Address: A1208, Overseas Decoration Building, #122 Zhenhua RD., Futian, Shenzhen, China



THIS COPY IS PROVIDED ON A RESTRICTED BASIS AND IS NOT TO BE USED IN ANY WAY DETRIMENTAL TO THE INTERESTS OF PANDUIT CORP.

(A)

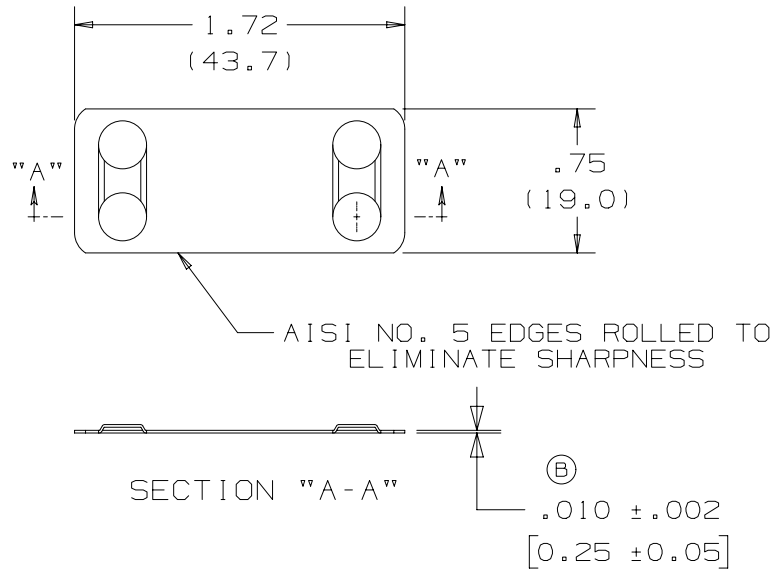

07A

PART NO.	MATERIAL	PKG. QTY.
MMP172-C	304 S.S.	100
MMP172-C316	316 S.S.	100
MMP172-M	304 S.S.	1000

NOTES:

1. DIMENSION IN () ARE mm.
2. CUSTOM PERMANENT MARKING AVAILABLE. CONSULT FACTORY.
3. USE WITH STD. CROSS SECTION MLT'S.
4. TOLERANCE (UNLESS OTHERWISE SPECIFIED):
 .XXX = ±.020 (.51)
 .XX = ±.03 (.8)

07A	12/11/17	RVU	CLW	JHAC	ADD MMP172-M TO TABLE WITH 1000 PIECES.	GAECN04428
06A	2/13	JAMB	MIM	RGRO	UPDATE DRAWING TO NEW PANDUIT TITLE BLOCK WITH PANDUIT LOGO	SSECN01031
05	1/07	JAMB	SKB	---	(B) ADDED THICKNESS DIMENSION TO SECTION "A-A"	SS00314
04	10/03	BRH	DPN	---	(A) ADDED PACKAGE QTY /CODE TO PART NUMBERS IN TABLE	11167
03	5/02	JAMB	DPN	---	REMOVED MATERIAL 302 SS FROM PART NO. MMP172	10041
02	2/01	KMD	SKB	---	FILE SPEC WAS N41045SA_PCD_01	09086
01	4/93	SM	LM	---	ADDED STK THK DIM	01532
00	3/91	SM	LM	---	RELEASED	00378
REV	DATE	BY	CHK	APR	DESCRIPTION	ECN

TITLE					
MINI STANDARD MARKER PLATE					
CUSTOMER DRAWING					
ITEM REVISION NAME	N41045BS/07				
DATASET FILE NAME	N41045BS_DC/07A				
UNLESS OTHERWISE SPECIFIED, DIMENSIONAL TOLERANCES ARE: IN (mm)	PANDUIT				
.X ± .XXX ± .XX ± .020 (.5) ANGES ±					
MATERIAL:	STAINLESS STEEL				
DRAWING NUMBER:	N41045BS_DC				
DRAWN BY	DATE	CHK	SCALE	DRAWING NUMBER:	SIZE
SAM	2/4/91	JAC	NONE	SHT 1 OF 1	A