



Chipsmall Limited consists of a professional team with an average of over 10 year of expertise in the distribution of electronic components. Based in Hongkong, we have already established firm and mutual-benefit business relationships with customers from,Europe,America and south Asia,supplying obsolete and hard-to-find components to meet their specific needs.

With the principle of “Quality Parts,Customers Priority,Honest Operation,and Considerate Service”,our business mainly focus on the distribution of electronic components. Line cards we deal with include Microchip,ALPS,ROHM,Xilinx,Pulse,ON,Everlight and Freescale. Main products comprise IC,Modules,Potentiometer,IC Socket,Relay,Connector.Our parts cover such applications as commercial,industrial, and automotives areas.

We are looking forward to setting up business relationship with you and hope to provide you with the best service and solution. Let us make a better world for our industry!



Contact us

Tel: +86-755-8981 8866 Fax: +86-755-8427 6832

Email & Skype: info@chipsmall.com Web: www.chipsmall.com

Address: A1208, Overseas Decoration Building, #122 Zhenhua RD., Futian, Shenzhen, China



RF Power LDMOS Transistor

N-Channel Enhancement-Mode Lateral MOSFET

Designed for handheld two-way radio applications with frequencies from 136 to 941 MHz. The high gain, ruggedness and wideband performance of this device make it ideal for large-signal, common-source amplifier applications in handheld military radio equipment.

Narrowband Performance (7.5 Vdc, I_{DQ} = 100 mA, T_A = 25°C, CW)

Frequency (MHz)	G _{ps} (dB)	η _D (%)	P _{out} (W)
870 ⁽¹⁾	15.2	71.0	7.3

Wideband Performance (7.5 Vdc, T_A = 25°C, CW)

Frequency (MHz)	P _{in} (W)	G _{ps} (dB)	η _D (%)	P _{out} (W)
136–174	0.25	14.6	69.0	7.2
350–470 ^(2,5)	0.20	15.6	60.9	7.3
450–520 ^(3,5)	0.22	15.4	56.0	7.5
760–860 ^(4,5)	0.23	15.1	48.1	7.5

Load Mismatch/Ruggedness

Frequency (MHz)	Signal Type	VSWR	P _{in} (W)	Test Voltage	Result
870 ⁽¹⁾	CW	> 65:1 at all Phase Angles	0.4 (3 dB Overdrive)	10.8	No Device Degradation

1. Measured in 870 MHz narrowband test circuit.
2. Measured in 350–470 MHz UHF broadband reference circuit.
3. Measured in 450–520 MHz UHF broadband reference circuit.
4. Measured in 760–860 MHz UHF broadband reference circuit.
5. The values shown are the minimum measured performance numbers across the indicated frequency range.

Features

- Characterized for Operation from 136 to 941 MHz
- Unmatched Input and Output Allowing Wide Frequency Range Utilization
- Integrated ESD Protection
- Integrated Stability Enhancements
- Wideband — Full Power Across the Band
- Exceptional Thermal Performance
- Extreme Ruggedness
- High Linearity for: TETRA, SSB
- In Tape and Reel. T1 Suffix = 1,000 Units, 16 mm Tape Width, 7-inch Reel.

Typical Applications

- Output Stage VHF Band Handheld Radio
- Output Stage UHF Band Handheld Radio
- Output Stage for 700–800 MHz Handheld Radio

MMRF1021NT1

**136–941 MHz, 7 W, 7.5 V
WIDEBAND
RF POWER LDMOS TRANSISTOR**

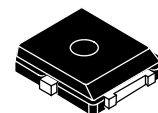

PLD-1.5W

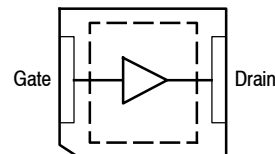

Note: The center pad on the backside of the package is the source terminal for the transistor.

Figure 1. Pin Connections

Table 1. Maximum Ratings

Rating	Symbol	Value	Unit
Drain-Source Voltage	V_{DSS}	-0.5, +30	Vdc
Gate-Source Voltage	V_{GS}	-6.0, +12	Vdc
Operating Voltage	V_{DD}	12.5, +0	Vdc
Storage Temperature Range	T_{stg}	-65 to +150	°C
Case Operating Temperature Range	T_C	-40 to +150	°C
Operating Junction Temperature (1,2)	T_J	-40 to +150	°C
Total Device Dissipation @ $T_C = 25^\circ\text{C}$ Derate above 25°C	P_D	114 0.91	W W/°C

Table 2. Thermal Characteristics

Characteristic	Symbol	Value (2,3)	Unit
Thermal Resistance, Junction to Case Case Temperature 74°C, 7 W CW, 7.5 Vdc, $I_{DQ} = 100$ mA, 870 MHz	$R_{\theta JC}$	1.1	°C/W

Table 3. ESD Protection Characteristics

Test Methodology	Class
Human Body Model (per JESD22-A114)	2, passes 2500 V
Machine Model (per EIA/JESD22-A115)	B, passes 200 V
Charge Device Model (per JESD22-C101)	IV, passes 2000 V

Table 4. Moisture Sensitivity Level

Test Methodology	Rating	Package Peak Temperature	Unit
Per JESD22-A113, IPC/JEDEC J-STD-020	3	260	°C

Table 5. Electrical Characteristics ($T_A = 25^\circ\text{C}$ unless otherwise noted)

Characteristic	Symbol	Min	Typ	Max	Unit
----------------	--------	-----	-----	-----	------

Off Characteristics

Zero Gate Voltage Drain Leakage Current ($V_{DS} = 30$ Vdc, $V_{GS} = 0$ Vdc)	I_{DSS}	—	—	10	μA dc
Zero Gate Voltage Drain Leakage Current ($V_{DS} = 7.5$ Vdc, $V_{GS} = 0$ Vdc)	I_{DSS}	—	—	2	μA dc
Gate-Source Leakage Current ($V_{GS} = 5$ Vdc, $V_{DS} = 0$ Vdc)	I_{GSS}	—	—	1	μA dc

On Characteristics

Gate Threshold Voltage ($V_{DS} = 10$ Vdc, $I_D = 110$ μA dc)	$V_{GS(th)}$	1.6	2.1	2.6	Vdc
Drain-Source On-Voltage ($V_{GS} = 10$ Vdc, $I_D = 1.1$ Adc)	$V_{DS(on)}$	—	0.12	—	Vdc
Forward Transconductance ($V_{DS} = 7.5$ Vdc, $I_D = 3$ Adc)	g_{fs}	—	9.8	—	S

Dynamic Characteristics

Reverse Transfer Capacitance ($V_{DS} = 7.5$ Vdc \pm 30 mV(rms)ac @ 1 MHz, $V_{GS} = 0$ Vdc)	C_{rss}	—	2.7	—	pF
Output Capacitance ($V_{DS} = 7.5$ Vdc \pm 30 mV(rms)ac @ 1 MHz, $V_{GS} = 0$ Vdc)	C_{oss}	—	56	—	pF
Input Capacitance ($V_{DS} = 7.5$ Vdc, $V_{GS} = 0$ Vdc \pm 30 mV(rms)ac @ 1 MHz)	C_{iss}	—	107	—	pF

1. Continuous use at maximum temperature will affect MTTF.
2. MTTF calculator available at <http://www.freescale.com/rf>. Select Software & Tools/Development Tools/Calculators to access MTTF calculators by product.
3. Refer to AN1955, *Thermal Measurement Methodology of RF Power Amplifiers*. Go to <http://www.freescale.com/rf>. Select Documentation/Application Notes - AN1955.

(continued)

Table 5. Electrical Characteristics ($T_A = 25^\circ\text{C}$ unless otherwise noted) **(continued)**

Characteristic	Symbol	Min	Typ	Max	Unit
----------------	--------	-----	-----	-----	------

Functional Tests (In Freescale Test Fixture, 50 ohm system) $V_{DD} = 7.5\text{ Vdc}$, $I_{DQ} = 100\text{ mA}$, $P_{in} = 0.22\text{ W}$, $f = 870\text{ MHz}$

Common-Source Amplifier Output Power	P_{out}	—	7.3	—	W
Drain Efficiency	η_D	—	71.0	—	%

Load Mismatch/Ruggedness (In Freescale Test Fixture, 50 ohm system) $I_{DQ} = 100\text{ mA}$

Frequency (MHz)	Signal Type	VSWR	P_{in} (W)	Test Voltage, V_{DD}	Result
870	CW	> 65:1 at all Phase Angles	0.4 (3 dB Overdrive)	10.8	No Device Degradation

TYPICAL CHARACTERISTICS

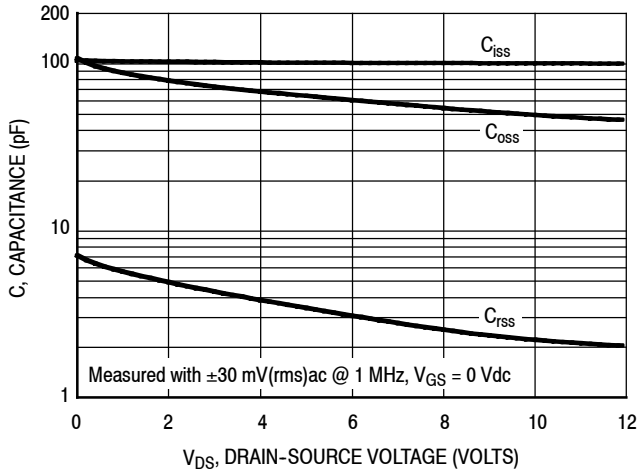

Figure 2. Capacitance versus Drain-Source Voltage

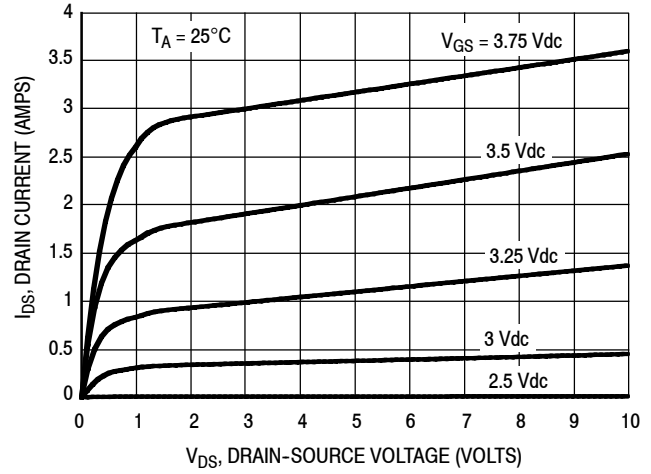
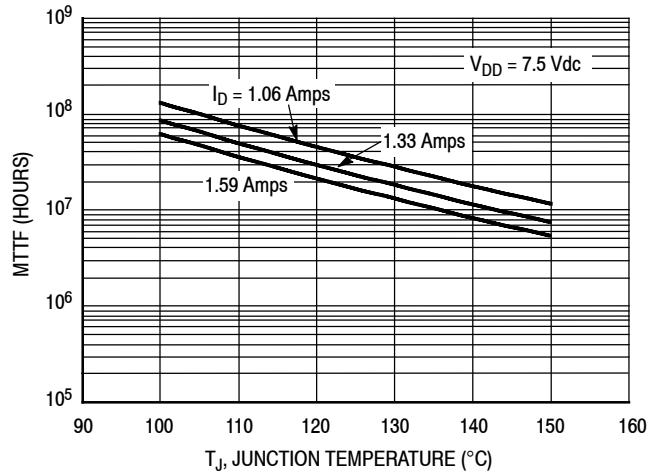

Figure 3. Drain Current versus Drain-Source Voltage



Note: MTTF value represents the total cumulative operating time under indicated test conditions.

MTTF calculator available at <http://www.freescale.com/rf>. Select Software & Tools/Development Tools/Calculators to access MTTF calculators by product.

Figure 4. MTTF versus Junction Temperature — CW

870 MHz NARROWBAND PRODUCTION TEST FIXTURE

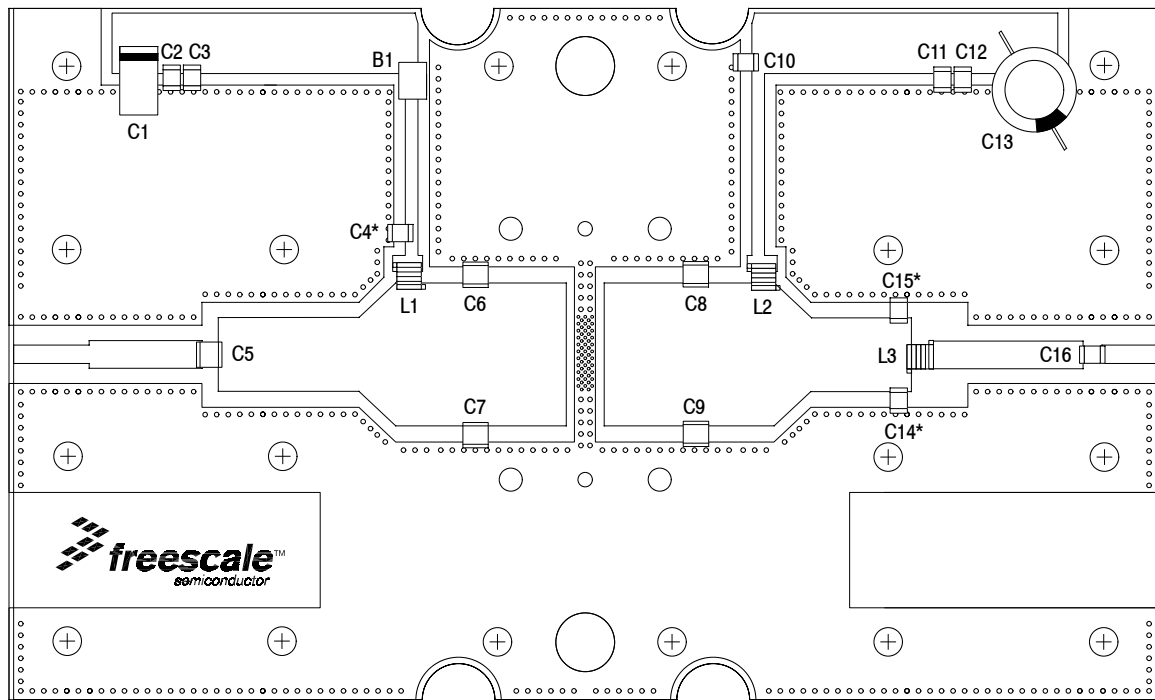

*C4, C14 and C15 are mounted vertically.

Figure 5. MMRF1021NT1 Narrowband Test Circuit Component Layout — 870 MHz

Table 6. MMRF1021NT1 Narrowband Test Circuit Component Designations and Values — 870 MHz

Part	Description	Part Number	Manufacturer
B1	RF Bead, Short	2743019447	Fair-Rite
C1	22 μ F, 35 V Tantalum Capacitor	T491X226K035AT	Kemet
C2, C12	0.1 μ F Chip Capacitors	CDR33BX104AKWS	Kemet
C3, C11	0.01 μ F Chip Capacitors	C0805C103K5RAC	Kemet
C4, C10, C16	56 pF Chip Capacitors	ATC100B560CT500XT	ATC
C5	3.9 pF Chip Capacitor	ATC100B3R9CT500XT	ATC
C6, C7	7.5 pF Chip Capacitors	ATC100B7R5CT500XT	ATC
C8, C9	6.8 pF Chip Capacitors	ATC100B6R8CT500XT	ATC
C13	330 μ F, 35 V Electrolytic Capacitor	MCGPR35V337M10X16-RH	Multicomp
C14, C15	3.6 pF Chip Capacitors	ATC100B3R6CT500XT	ATC
L1	8.0 nH Inductor	A03TKLC	Coilcraft
L2	18.5 nH Inductor	A05TKLC	Coilcraft
L3	5.0 nH Inductor	A02TKLC	Coilcraft
PCB	Rogers RO4350B, 0.030", $\epsilon_r = 3.66$	—	MTL

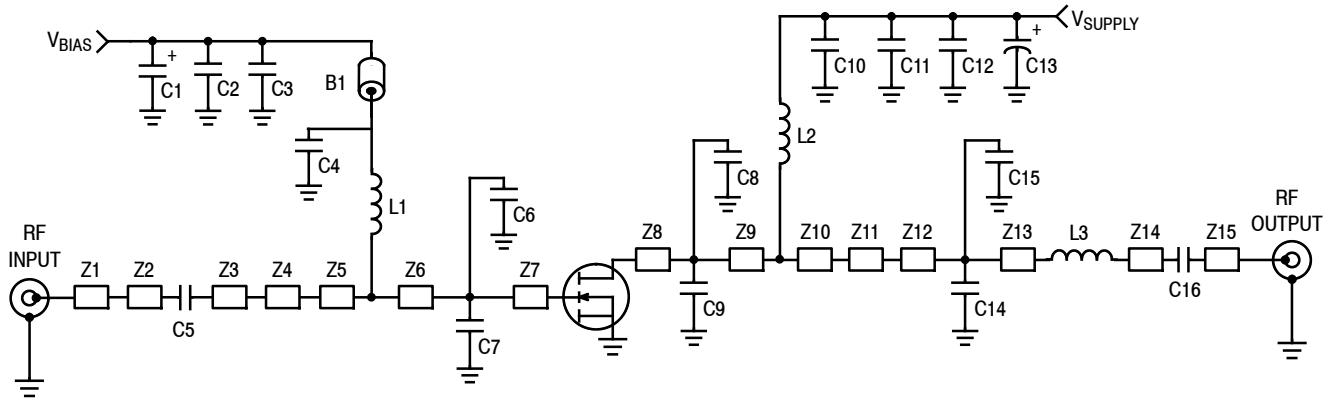

Figure 6. MMRF1021NT1 Narrowband Test Circuit Schematic — 870 MHz

Table 7. MMRF1021NT1 Narrowband Test Circuit Microstrips — 870 MHz

Microstrip	Description
Z1	0.328" × 0.080" Microstrip
Z2	0.490" × 0.120" Microstrip
Z3	0.610" × 0.320" Microstrip
Z4	0.160" × 0.320" × 0.620" Taper
Z5	0.058" × 0.620" Microstrip
Z6	0.288" × 0.620" Microstrip
Z7	0.394" × 0.620" Microstrip
Z8	0.398" × 0.620" Microstrip

Microstrip	Description
Z9	0.295" × 0.620" Microstrip
Z10	0.046" × 0.620" Microstrip
Z11	0.159" × 0.620" × 0.320" Taper
Z12	0.379" × 0.320" Microstrip
Z13	0.055" × 0.320" Microstrip
Z14	0.665" × 0.120" Microstrip
Z15	0.238" × 0.080" Microstrip

TYPICAL CHARACTERISTICS — 870 MHz

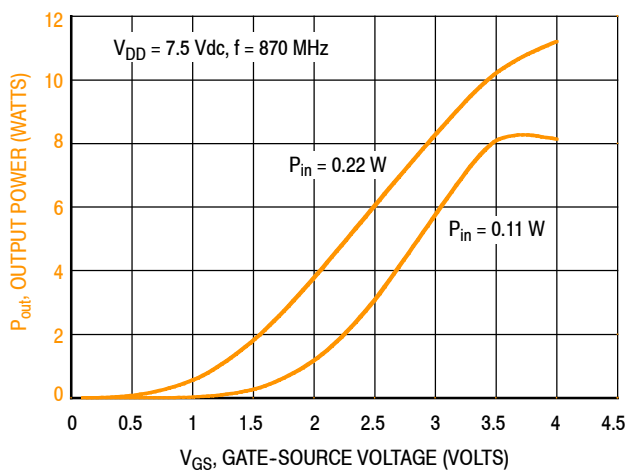

Figure 7. Output Power versus Gate-Source Voltage at a Constant Input Power

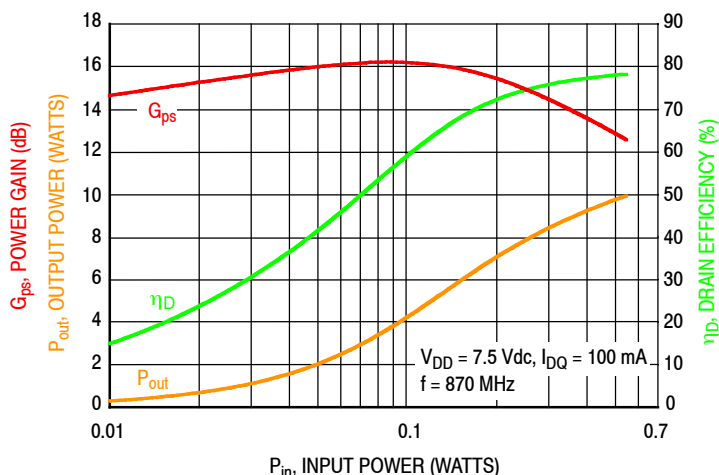

Figure 8. Power Gain, Output Power and Drain Efficiency versus Input Power

$V_{DD} = 7.5 \text{ Vdc}, I_{DQ} = 100 \text{ mA}, P_{out} = 7 \text{ W}$

f MHz	Z_{source} Ω	Z_{load} Ω
870	$0.54 + j1.35$	$1.31 + j1.93$

Z_{source} = Test circuit impedance as measured from gate to ground.

Z_{load} = Test circuit impedance as measured from drain to ground.

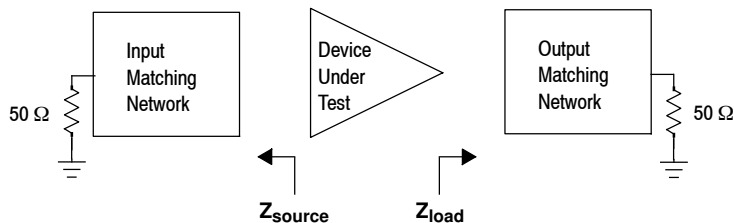

Figure 9. Narrowband Series Equivalent Source and Load Impedance — 870 MHz

350–470 MHz UHF BROADBAND REFERENCE CIRCUIT

Table 8. 350–470 MHz UHF Broadband Performance (In Freescale Reference Circuit, 50 ohm system)

$V_{DD} = 7.5 \text{ Vdc}$, $I_{DQ} = 200 \text{ mA}$, $T_A = 25^\circ\text{C}$, CW

Frequency (MHz)	P_{in} (W)	G_{ps} (dB)	η_D (%)	P_{out} (W)
350	0.15	16.6	60.9	7.3
410	0.15	16.6	66.5	7.3
470	0.20	15.6	70.1	7.3

Table 9. Load Mismatch/Ruggedness (In Freescale Reference Circuit)

Frequency (MHz)	Signal Type	VSWR	P_{in} (W)	Test Voltage, V_{DD}	Result
470	CW	> 65:1 at all Phase Angles	0.4 (3 dB Overdrive)	10.8	No Device Degradation

350–470 MHz UHF BROADBAND REFERENCE CIRCUIT

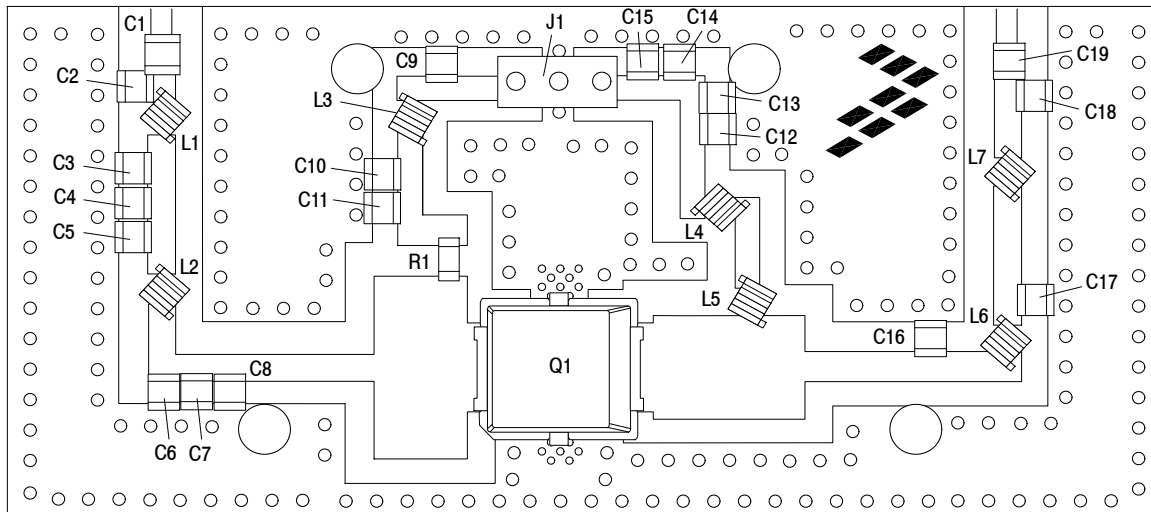

Figure 10. MMRF1021NT1 UHF Broadband Reference Circuit Component Layout — 350–470 MHz

Table 10. MMRF1021NT1 UHF Broadband Reference Circuit Component Designations and Values — 350–470 MHz

Part	Description	Part Number	Manufacturer
C1, C10, C19	100 pF Chip Capacitors	ATC600F101JT250XT	ATC
C2	10 pF Chip Capacitor	ATC600F100JT250XT	ATC
C3	3.0 pF Chip Capacitor	ATC600F3R0BT250XT	ATC
C4, C8	27 pF Chip Capacitors	ATC600F270JT250XT	ATC
C5	5.1 pF Chip Capacitor	ATC600F5R1BT250XT	ATC
C6, C7	30 pF Chip Capacitors	ATC600F300JT250XT	ATC
C9	10 nF Chip Capacitor	C1210C103J5GAC-TU	Kemet
C11	82 pF Chip Capacitor	ATC600F820JT250XT	ATC
C12	240 pF Chip Capacitor	ATC600F241JT250XT	ATC
C13	2.2 μ F Chip Capacitor	C3225X7R1H225K250AB	TDK
C14	0.1 μ F Chip Capacitor	GRM21BR71H104KA01B	Murata
C15	0.01 μ F Chip Capacitor	GRM21BR72A103KA01B	Murata
C16	47 pF Chip Capacitor	ATC600F470JT250XT	ATC
C17	18 pF Chip Capacitor	ATC600F180BT250XT	ATC
C18	7.5 pF Chip Capacitor	ATC100A7R5JT150XT	ATC
J1	3-pin Header	22-28-8360	Molex
L1	8.1 nH Inductor	0908SQ8N1	Coilcraft
L2	2.55 nH, 3 Turn Inductor	0906-3JLC	Coilcraft
L3, L4, L5	21.5 nH Inductors	0908SQ22N	Coilcraft
L6	3.85 nH, 4 Turn Inductor	0906-4JLC	Coilcraft
L7	8.9 nH Inductor	0806SQ8N9	Coilcraft
Q1	RF Power LDMOS Transistor	MMRF1021NT1	Freescale
R1	62 Ω , 1/10 W Chip Resistor	RG2012N-620-B-T1	Susumu
PCB	Shengyi S1000-2, 0.020", $\epsilon_r = 4.8$	—	MTL

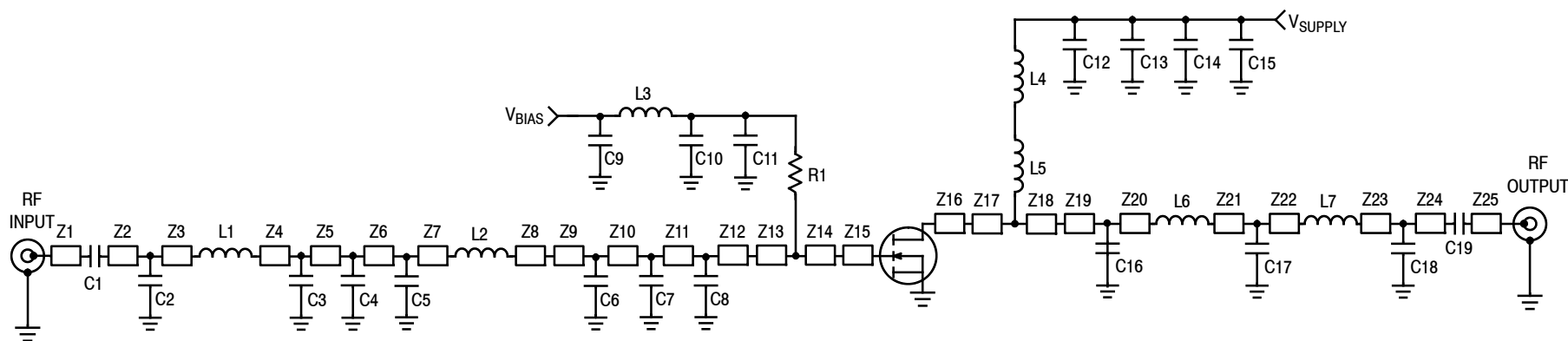

Figure 11. MMRF1021NT1 UHF Broadband Reference Circuit Schematic — 350–470 MHz

Table 11. MMRF1021NT1 UHF Broadband Reference Circuit Microstrips — 350–470 MHz

Microstrip	Description	Microstrip	Description	Microstrip	Description
Z1	0.060" × 0.034" Microstrip	Z10	0.037" × 0.046" Microstrip	Z18	0.088" × 0.170" Microstrip
Z2	0.026" × 0.046" Microstrip	Z11	0.055" × 0.046" Microstrip	Z19	0.205" × 0.046" Microstrip
Z3	0.026" × 0.046" Microstrip	Z12	0.235" × 0.046" Microstrip	Z20	0.148" × 0.046" Microstrip
Z4	0.060" × 0.046" Microstrip	Z13	0.121" × 0.300" Microstrip	Z21	0.032" × 0.046" Microstrip
Z5	0.054" × 0.046" Microstrip	Z14	0.031" × 0.300" Microstrip	Z22	0.195" × 0.046" Microstrip
Z6	0.054" × 0.046" Microstrip	Z15	0.070" × 0.146" Microstrip	Z23	0.089" × 0.046" Microstrip
Z7	0.060" × 0.046" Microstrip	Z16	0.070" × 0.146" Microstrip	Z24	0.046" × 0.046" Microstrip
Z8	0.084" × 0.046" Microstrip	Z17	0.160" × 0.170" Microstrip	Z25	0.060" × 0.034" Microstrip
Z9	0.044" × 0.046" Microstrip				

TYPICAL CHARACTERISTICS — 350–470 MHz UHF BROADBAND REFERENCE CIRCUIT

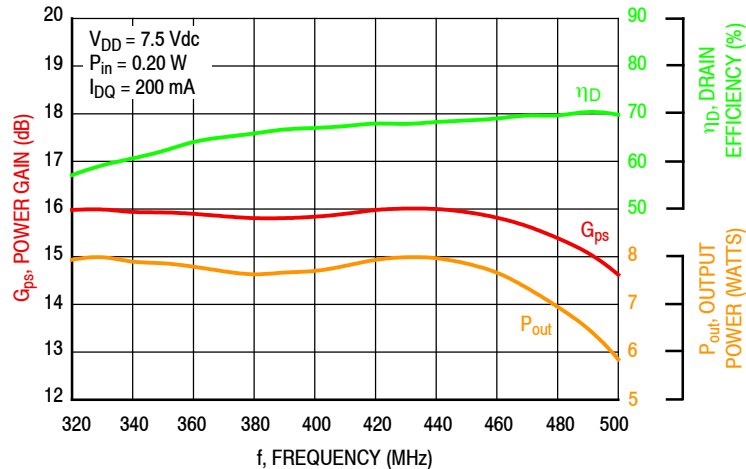

Figure 12. Power Gain, Drain Efficiency and Output Power versus Frequency at a Constant Input Power

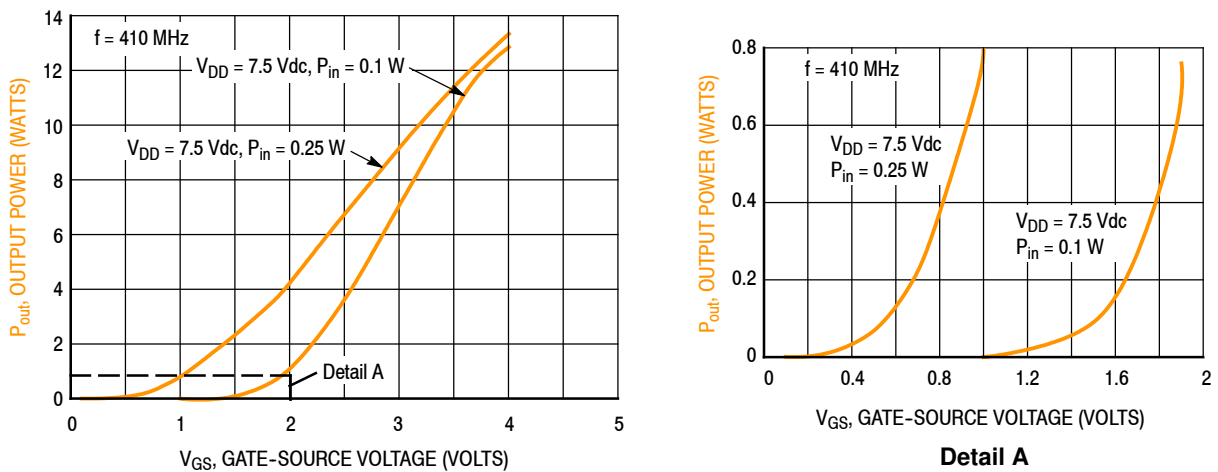

Figure 13. Output Power versus Gate-Source Voltage

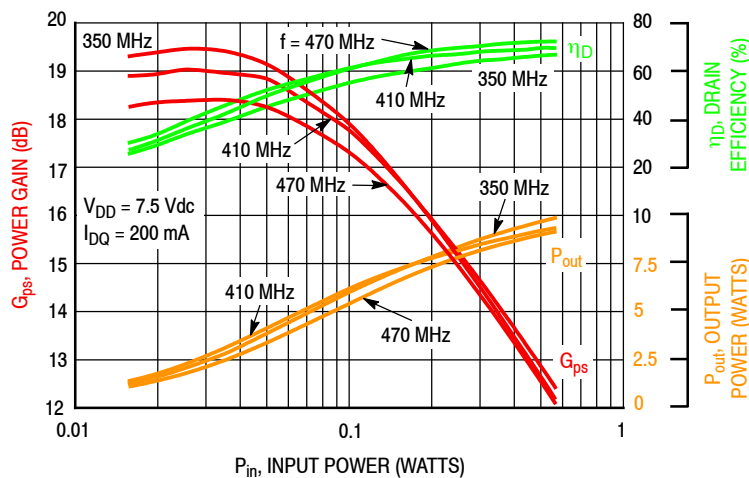
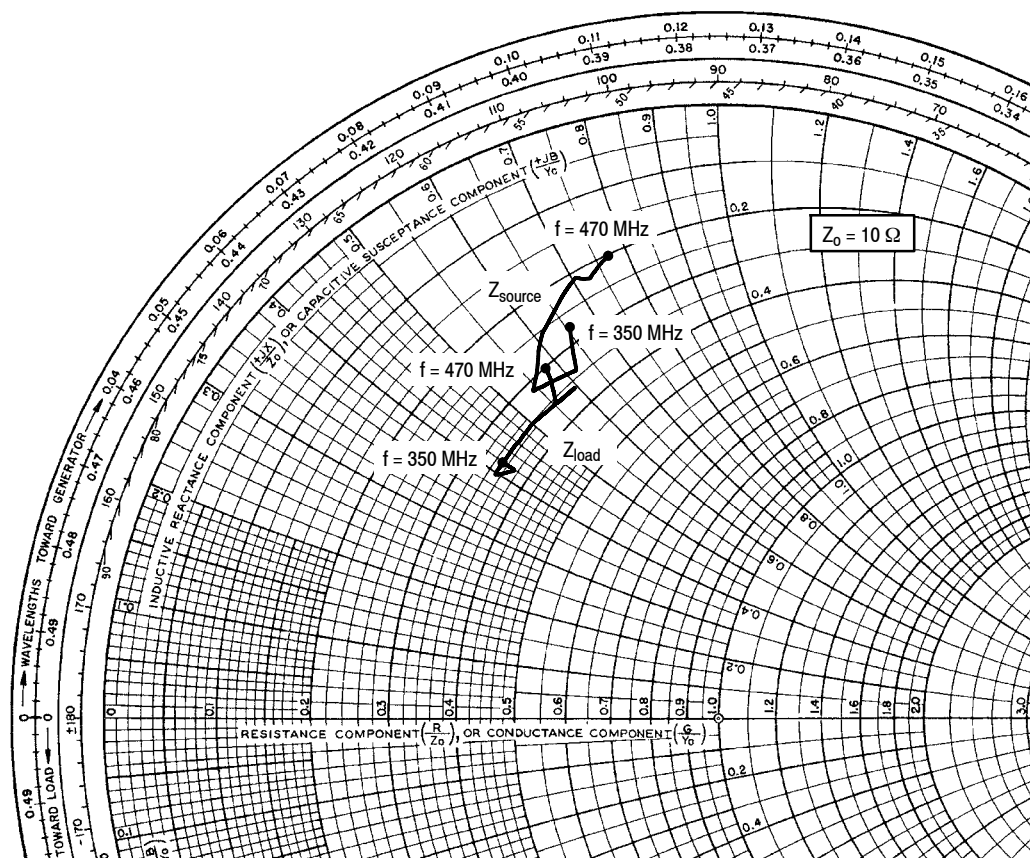

Figure 14. Power Gain, Drain Efficiency and Output Power versus Input Power and Frequency

350–470 MHz UHF BROADBAND REFERENCE CIRCUIT



$V_{DD} = 7.5 \text{ Vdc}$, $I_{DQ} = 200 \text{ mA}$, $P_{out} = 7.5 \text{ W}$

f MHz	Z_{source} Ω	Z_{load} Ω
350	$2.7 + j6.6$	$3.5 + j4.2$
370	$3.3 + j6.2$	$3.7 + j4.2$
390	$3.1 + j5.4$	$3.5 + j4.0$
410	$2.6 + j6.1$	$3.5 + j5.0$
430	$2.1 + j7.1$	$3.6 + j5.9$
450	$2.2 + j7.3$	$3.6 + j5.6$
470	$2.0 + j7.7$	$3.0 + j5.8$

Z_{source} = Test circuit impedance as measured from gate to ground.

Z_{load} = Test circuit impedance as measured from drain to ground.

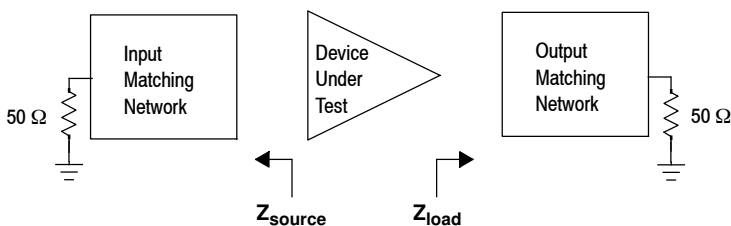

Figure 15. UHF Broadband Series Equivalent Source and Load Impedance — 350–470 MHz

450–520 MHz UHF BROADBAND REFERENCE CIRCUIT

Table 12. 450–520 MHz UHF Broadband Performance (In Freescale Reference Circuit, 50 ohm system)

$V_{DD} = 7.5 \text{ Vdc}$, $I_{DQ} = 150 \text{ mA}$, $T_A = 25^\circ\text{C}$, CW

Frequency (MHz)	P_{in} (W)	G_{ps} (dB)	η_D (%)	P_{out} (W)
450	0.21	15.4	57.7	7.5
485	0.21	15.5	56.0	7.5
520	0.18	16.2	66.3	7.5

Table 13. Load Mismatch/Ruggedness (In Freescale Reference Circuit)

Frequency (MHz)	Signal Type	VSWR	P_{in} (W)	Test Voltage, V_{DD}	Result
520	CW	> 65:1 at all Phase Angles	0.2 (3 dB Overdrive)	10.8	No Device Degradation

450–520 MHz UHF BROADBAND REFERENCE CIRCUIT

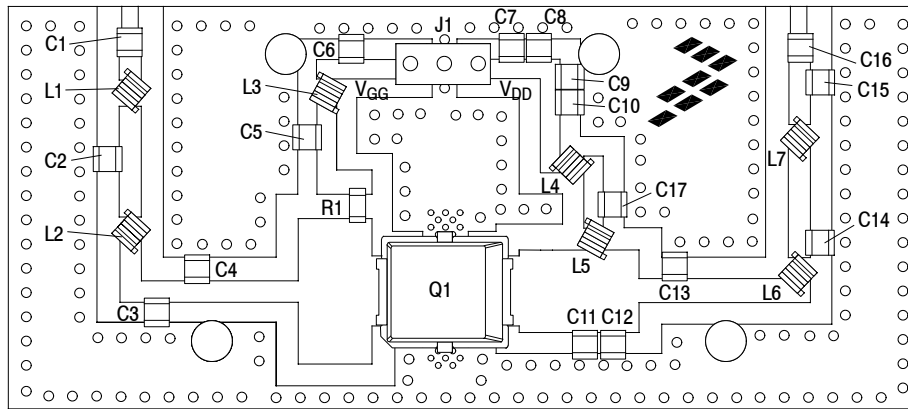

Figure 16. MMRF1021NT1 UHF Broadband Reference Circuit Component Layout — 450–520 MHz

Table 14. MMRF1021NT1 UHF Broadband Reference Circuit Component Designations and Values — 450–520 MHz

Part	Description	Part Number	Manufacturer
C1, C16	100 pF Chip Capacitors	ATC600F101JT250XT	ATC
C2	7.5 pF Chip Capacitor	GQM2195C2E7R5BB12D	Murata
C3	5.6 pF Chip Capacitor	ATC600F5R6BT250XT	ATC
C4	39 pF Chip Capacitor	ATC600F390JT250XT	ATC
C5, C9	240 pF Chip Capacitors	ATC600F241JT250XT	ATC
C6, C7	0.1 μ F Chip Capacitors	GRM21BR71H104KA01B	Murata
C8	0.01 μ F Chip Capacitor	GRM21BR72A103KA01B	Murata
C10	2.2 μ F Chip Capacitor	GRM31CR71H225KA88L	Murata
C11, 12	12 pF Chip Capacitors	ATC600F120JT250XT	ATC
C13	8.2 pF Chip Capacitor	ATC600F8R2BT250XT	ATC
C14	20 pF Chip Capacitor	ATC600F200JT250XT	ATC
C15	2 pF Chip Capacitor	ATC600F2R0BT250XT	ATC
C17	47 pF Chip Capacitor	ATC600F470JT250XT	ATC
J1	3-pin Header	22-28-8360	Molex
L1	2.55 nH Inductor	0906-3JLC	Coilcraft
L2	3.85 nH Inductor	0906-4JLC	Coilcraft
L3	22 nH Inductor	0908SQ22N	Coilcraft
L4, L5	17 nH Inductors	0908SQ17N	Coilcraft
L6	1.65 nH Inductor	0906-2JLC	Coilcraft
L7	8.1 nH Inductor	0908SQ8R1N	Coilcraft
R1	22 Ω , 1/10 W Chip Resistor	RR1220Q-220-D	Susumu
Q1	RF Power LDMOS Transistor	MMRF1021NT1	Freescale
PCB	Shengyi S1000-2, 0.020", $\epsilon_r = 4.8$	—	MTL

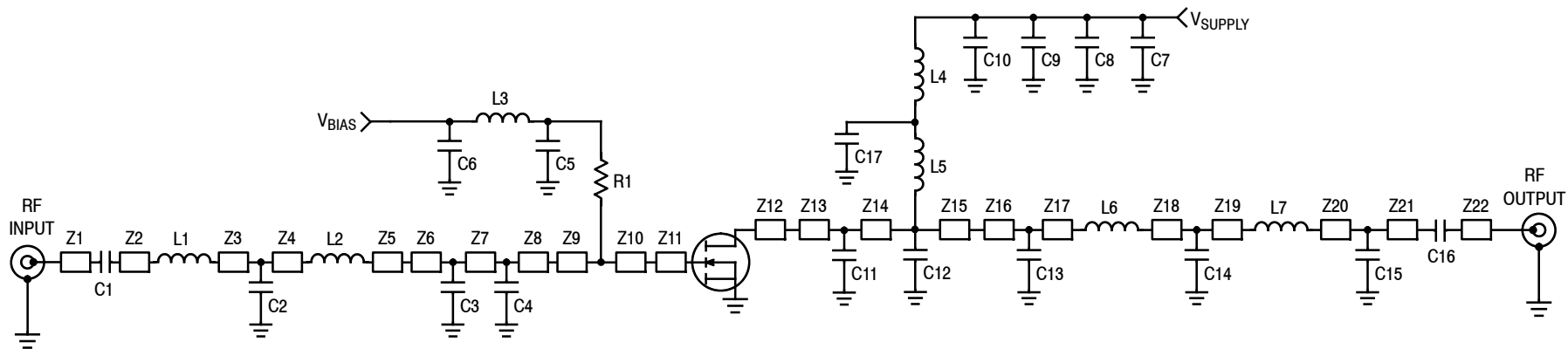

Figure 17. MMRF1021NT1 UHF Broadband Reference Circuit Schematic — 450–520 MHz

Table 15. MMRF1021NT1 UHF Broadband Reference Circuit Microstrips — 450–520 MHz

Microstrip	Description	Microstrip	Description	Microstrip	Description
Z1	0.060" × 0.034" Microstrip	Z9	0.121" × 0.300" Microstrip	Z16	0.075" × 0.049" Microstrip
Z2	0.052" × 0.046" Microstrip	Z10	0.031" × 0.300" Microstrip	Z17	0.279" × 0.049" Microstrip
Z3	0.110" × 0.046" Microstrip	Z11	0.070" × 0.146" Microstrip	Z18	0.032" × 0.046" Microstrip
Z4	0.118" × 0.046" Microstrip	Z12	0.070" × 0.146" Microstrip	Z19	0.195" × 0.046" Microstrip
Z5	0.084" × 0.046" Microstrip	Z13	0.138" × 0.170" Microstrip	Z20	0.089" × 0.046" Microstrip
Z6	0.124" × 0.046" Microstrip	Z14	0.055" × 0.170" Microstrip	Z21	0.046" × 0.046" Microstrip
Z7	0.084" × 0.046" Microstrip	Z15	0.055" × 0.170" Microstrip	Z22	0.060" × 0.034" Microstrip
Z8	0.207" × 0.046" Microstrip				

TYPICAL CHARACTERISTICS — 450–520 MHz UHF BROADBAND REFERENCE CIRCUIT

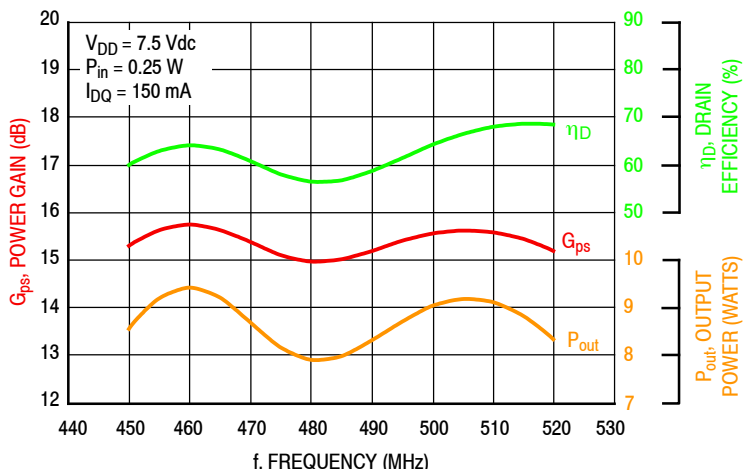

Figure 18. Power Gain, Output Power and Drain Efficiency versus Frequency at a Constant Input Power — 7.5 V

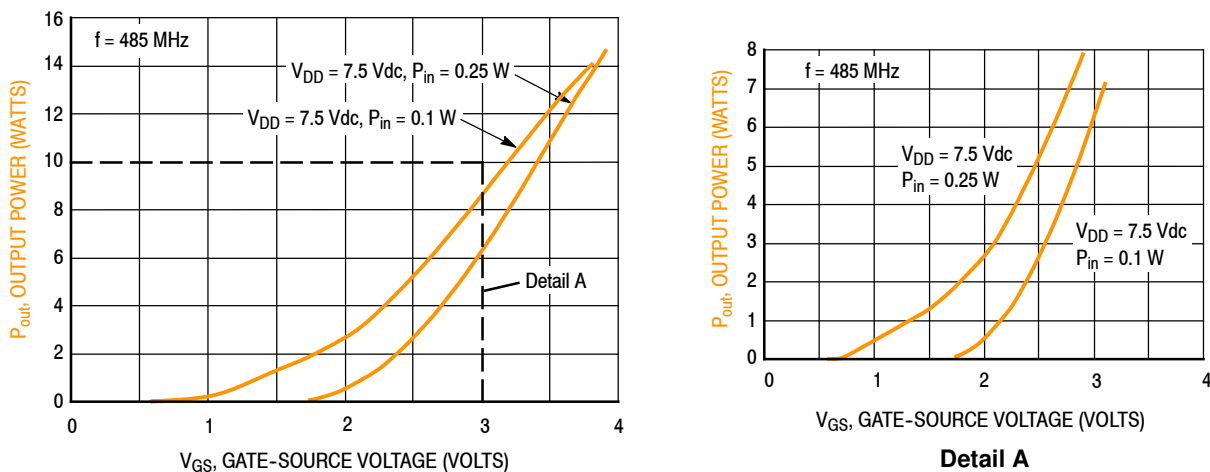

Figure 19. Output Power versus Gate-Source Voltage

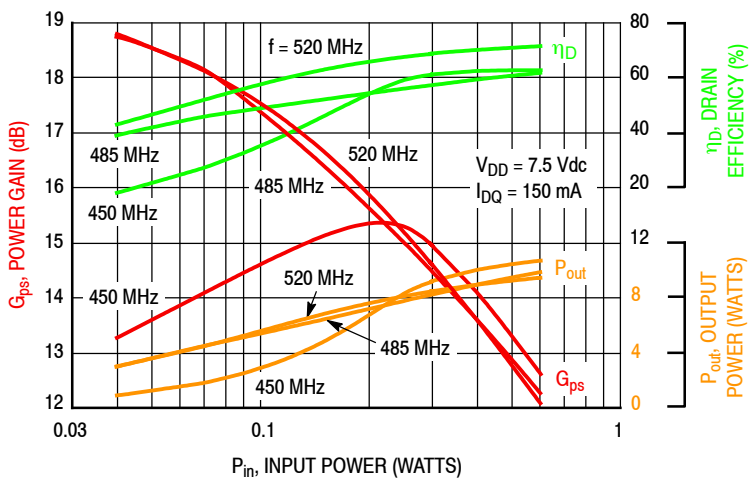
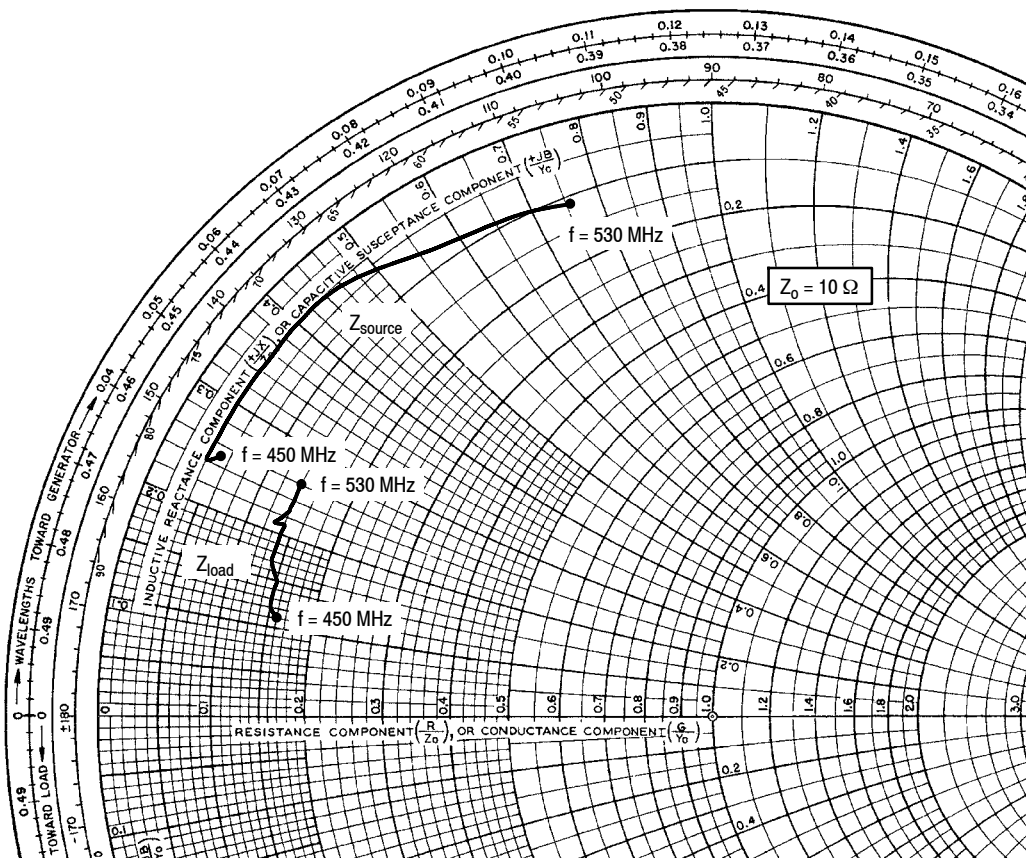

Figure 20. Power Gain, Output Power and Drain Efficiency versus Input Power and Frequency

450–520 MHz UHF BROADBAND REFERENCE CIRCUIT



$V_{DD} = 7.5 \text{ Vdc}$, $I_{DQ} = 150 \text{ mA}$, $P_{out} = 7.5 \text{ W}$

f MHz	Z_{source} Ω	Z_{load} Ω
450	$0.45 + j2.46$	$1.56 + j1.05$
460	$0.40 + j2.37$	$1.52 + j1.24$
470	$0.40 + j2.97$	$1.46 + j1.51$
480	$0.38 + j3.56$	$1.39 + j1.71$
490	$0.41 + j4.16$	$1.35 + j2.06$
500	$0.51 + j4.79$	$1.34 + j2.06$
510	$0.70 + j5.54$	$1.37 + j2.30$
520	$0.93 + j6.44$	$1.40 + j2.50$
530	$1.14 + j7.56$	$1.42 + j2.62$

Z_{source} = Test circuit impedance as measured from gate to ground.

Z_{load} = Test circuit impedance as measured from drain to ground.

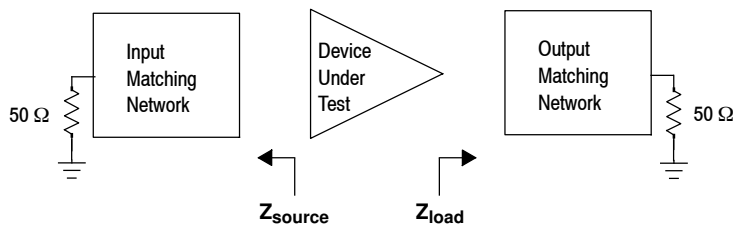

Figure 21. UHF Broadband Series Equivalent Source and Load Impedance — 450–520 MHz

760–860 MHz BROADBAND REFERENCE CIRCUIT

Table 16. 760–860 MHz Broadband Performance (In Freescale Reference Circuit, 50 ohm system)

$V_{DD} = 7.5 V_{DC}$, $I_{DQ} = 150 \text{ mA}$, $T_A = 25^\circ\text{C}$, CW

Frequency (MHz)	P_{in} (W)	G_{ps} (dB)	η_D (%)	P_{out} (W)
760	0.20	15.3	48.1	7.0
810	0.16	16.3	54.1	7.0
860	0.21	15.1	59.5	7.0

Table 17. Load Mismatch/Ruggedness (In Freescale Reference Circuit)

Frequency (MHz)	Signal Type	VSWR	P_{in} (W)	Test Voltage, V_{DD}	Result
810	CW	> 65:1 at all Phase Angles	0.5 (3 dB Overdrive)	9.0	No Device Degradation

760–860 MHz BROADBAND REFERENCE CIRCUIT

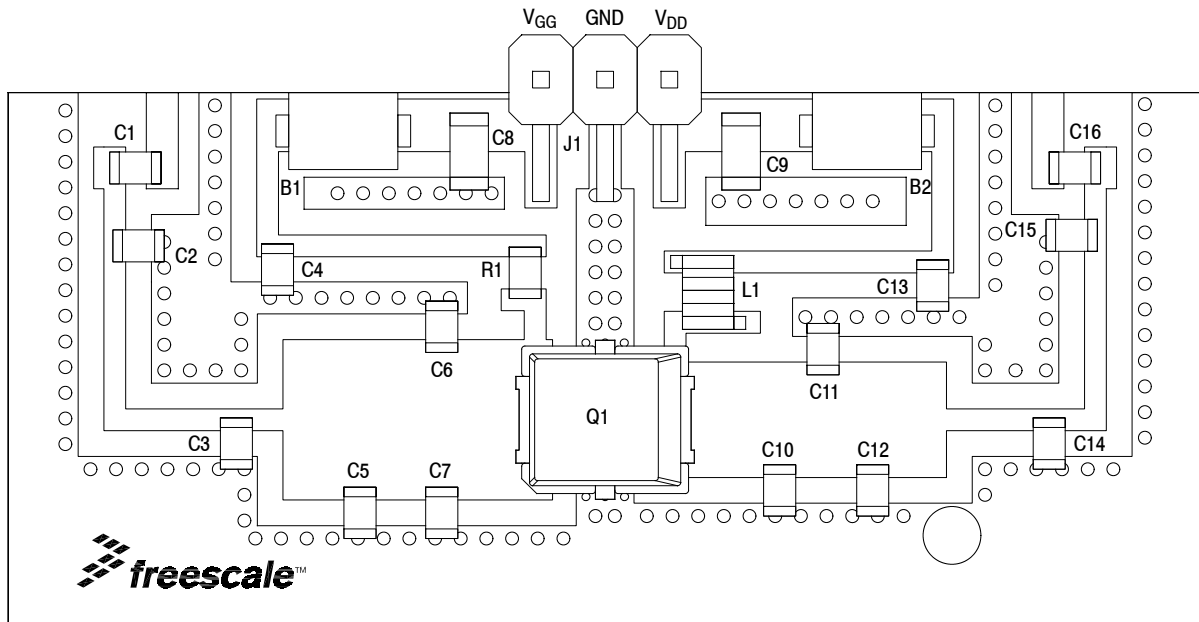

Figure 22. MMRF1021NT1 Broadband Reference Circuit Component Layout — 760–860 MHz

Table 18. MMRF1021NT1 Broadband Reference Circuit Component Designations and Values — 760–860 MHz

Part	Description	Part Number	Manufacturer
B1, B2	RF Beads	2743019447	Fair-Rite
C1	10 pF Chip Capacitor	GQM2195C2E100FB15	Murata
C2	3.9 pF Chip Capacitor	GQM2195C2E3R9BB15	Murata
C3	7.5 pF Chip Capacitor	GQM2195C2E7R5BB15	Murata
C4, C13, C16	100 pF Chip Capacitors	GQM2195C2E101GB15	Murata
C5	8.2 pF Chip Capacitor	GQM2195C2E8R2BB15	Murata
C6, C7	20 pF Chip Capacitors	GQM2195C2E200GB15	Murata
C8	1 μ F Chip Capacitor	GRM31MR71H105KA88L	Murata
C9	10 μ F Chip Capacitor	GRM31CR61H106KA12L	Murata
C10, C11	12 pF Chip Capacitors	GQM2195C2E120FB15	Murata
C12	5.1 pF Chip Capacitor	GQM2195C2E5R1BB15	Murata
C14	4.7 pF Chip Capacitor	GQM2195C2E4R7BB15	Murata
C15	3.9 pF Chip Capacitor	GQM2195C2E3R9BB15	Murata
J1	3-pin Header	22-28-8360	Molex
L1	22 nH Inductor	0908SQ-22NJL	Coilcraft
Q1	RF Power LDMOS Transistor	MMRF1021NT1	Freescale
R1	200 Ω Chip Resistor	CRCW0805200RJNEA	Vishay
PCB	Shengyi S1000-2, 0.020", $\epsilon_r = 4.8$	—	MTL

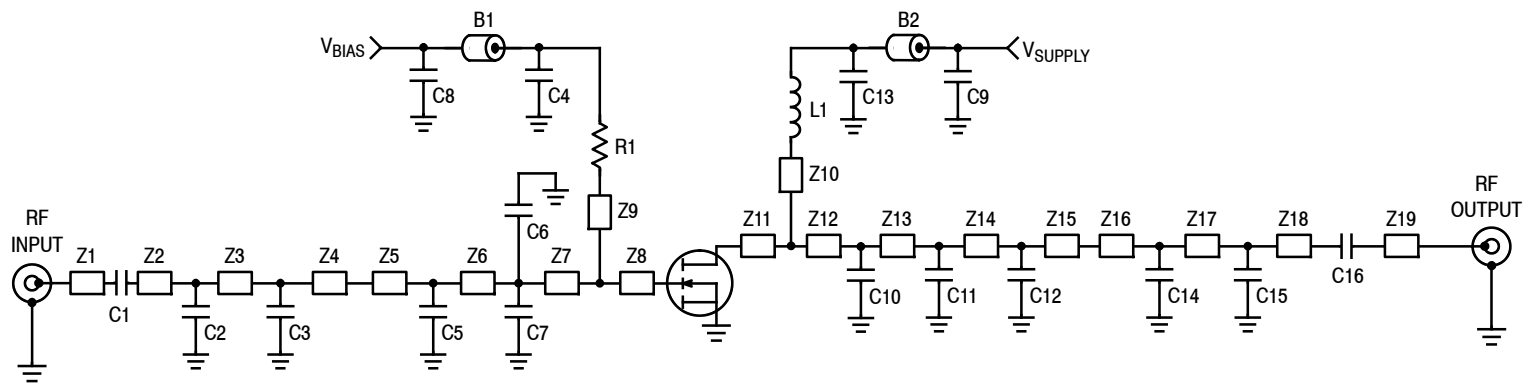

Figure 23. MMRF1021NT1 Broadband Reference Circuit Schematic — 760–860 MHz

Table 19. MMRF1021NT1 Broadband Reference Circuit Microstrips — 760–860 MHz

Microstrip	Description	Microstrip	Description	Microstrip	Description
Z1	0.150" × 0.050" Microstrip	Z8	0.027" × 0.250" Microstrip	Z15	0.115" × 0.180" Microstrip
Z2	0.120" × 0.034" Microstrip	Z9	0.066" × 0.034" Microstrip	Z16	0.160" × 0.034" Microstrip
Z3	0.460" × 0.034" Microstrip	Z10	0.110" × 0.034" Microstrip	Z17	0.360" × 0.034" Microstrip
Z4	0.073" × 0.034" Microstrip	Z11	0.027" × 0.180" Microstrip	Z18	0.105" × 0.034" Microstrip
Z5	0.120" × 0.250" Microstrip	Z12	0.163" × 0.180" Microstrip	Z19	0.150" × 0.050" Microstrip
Z6	0.128" × 0.250" Microstrip	Z13	0.068" × 0.180" Microstrip		
Z7	0.145" × 0.250" Microstrip	Z14	0.077" × 0.180" Microstrip		

* Line length includes microstrip bends.

TYPICAL CHARACTERISTICS — 760–860 MHz BROADBAND REFERENCE CIRCUIT

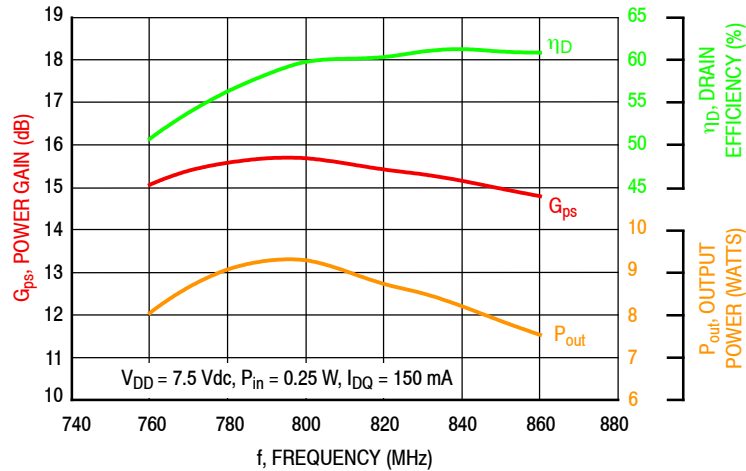

Figure 24. Power Gain, Output Power and Drain Efficiency versus Frequency at a Constant Input Power — 7.5 V

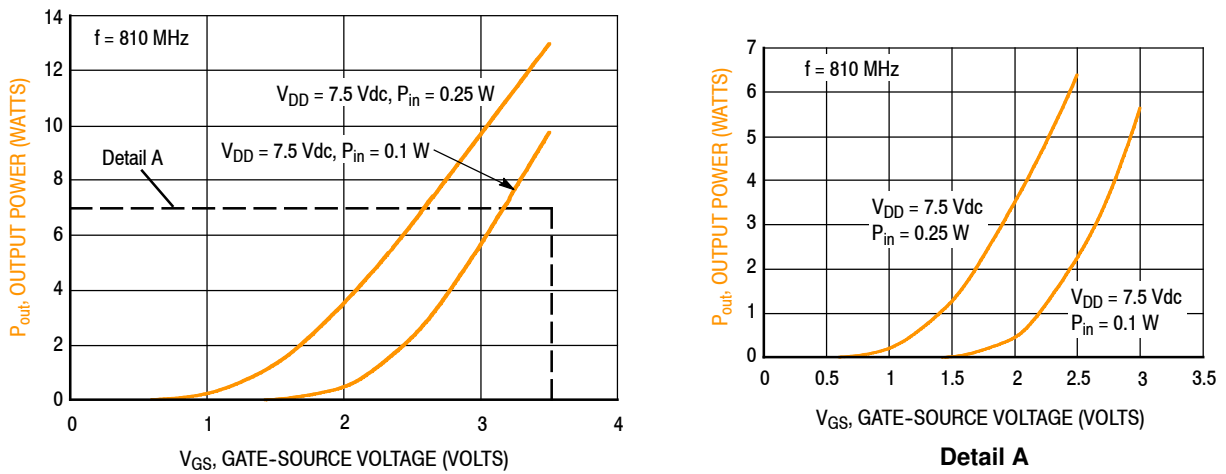

Figure 25. Output Power versus Gate-Source Voltage

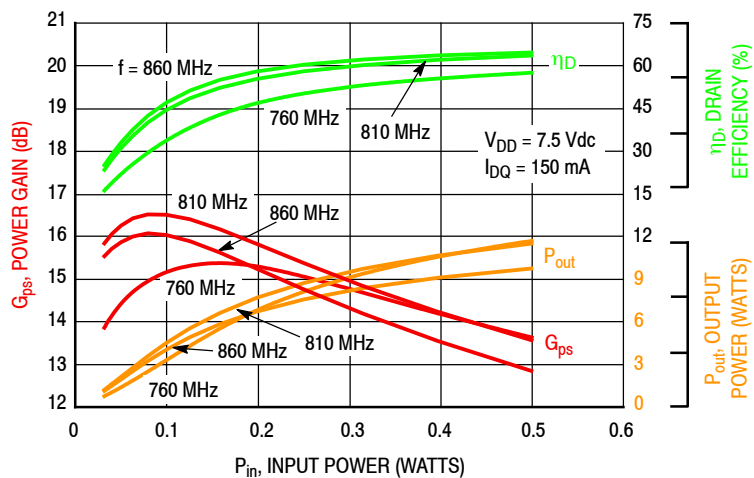
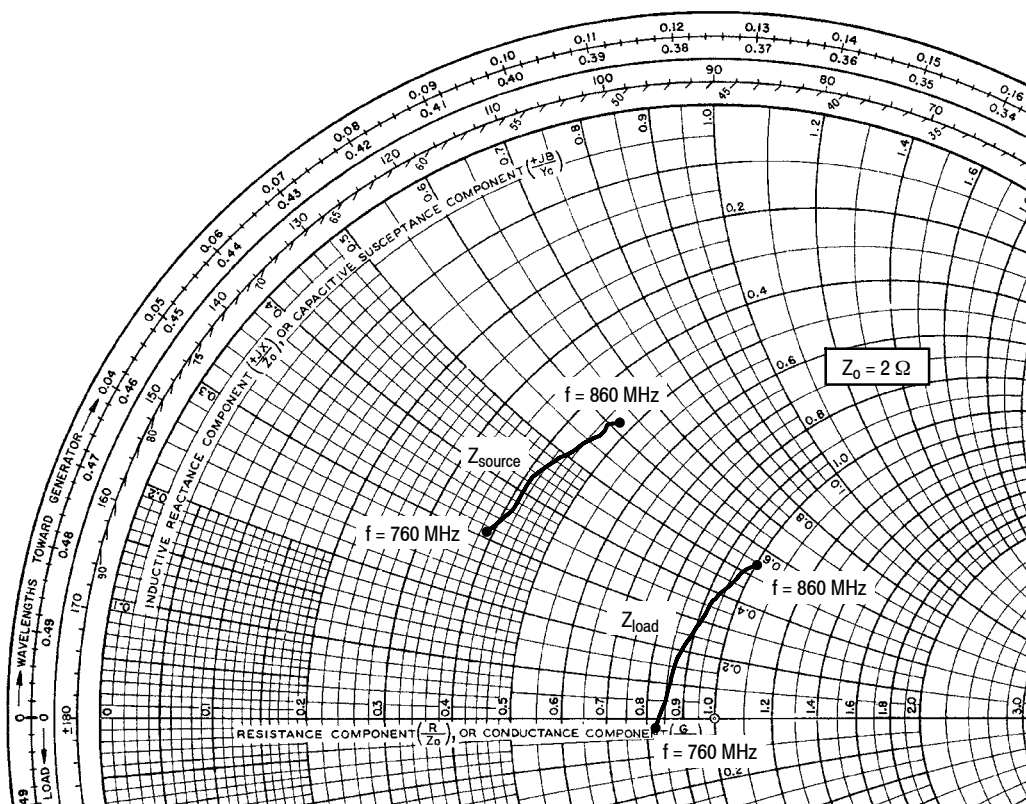

Figure 26. Power Gain, Output Power and Drain Efficiency versus Input Power and Frequency

760–860 MHz BROADBAND REFERENCE CIRCUIT



$V_{DD} = 7.5 \text{ Vdc}$, $I_{DQ} = 150 \text{ mA}$, $P_{out} = 7 \text{ W}$

f MHz	Z_{source} Ω	Z_{load} Ω
760	$0.77 + j0.62$	$1.65 - j0.04$
770	$0.81 + j0.71$	$1.70 + j0.10$
780	$0.81 + j0.79$	$1.72 + j0.24$
790	$0.82 + j0.85$	$1.74 + j0.36$
800	$0.84 + j0.92$	$1.77 + j0.49$
810	$0.85 + j0.98$	$1.81 + j0.61$
820	$0.88 + j1.02$	$1.84 + j0.69$
830	$0.89 + j1.07$	$1.87 + j0.79$
840	$0.91 + j1.13$	$1.91 + j0.90$
850	$0.91 + j1.19$	$1.93 + j0.99$
860	$0.94 + j1.23$	$1.99 + j1.08$

Z_{source} = Test circuit impedance as measured from gate to ground.

Z_{load} = Test circuit impedance as measured from drain to ground.

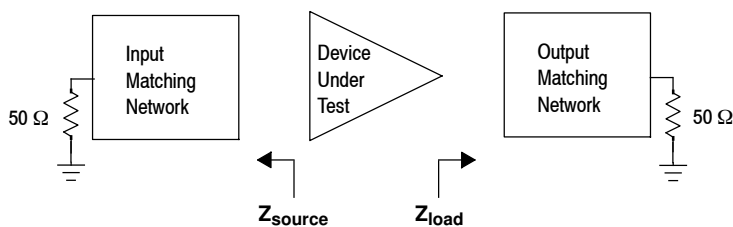

Figure 27. Broadband Series Equivalent Source and Load Impedance — 760–860 MHz

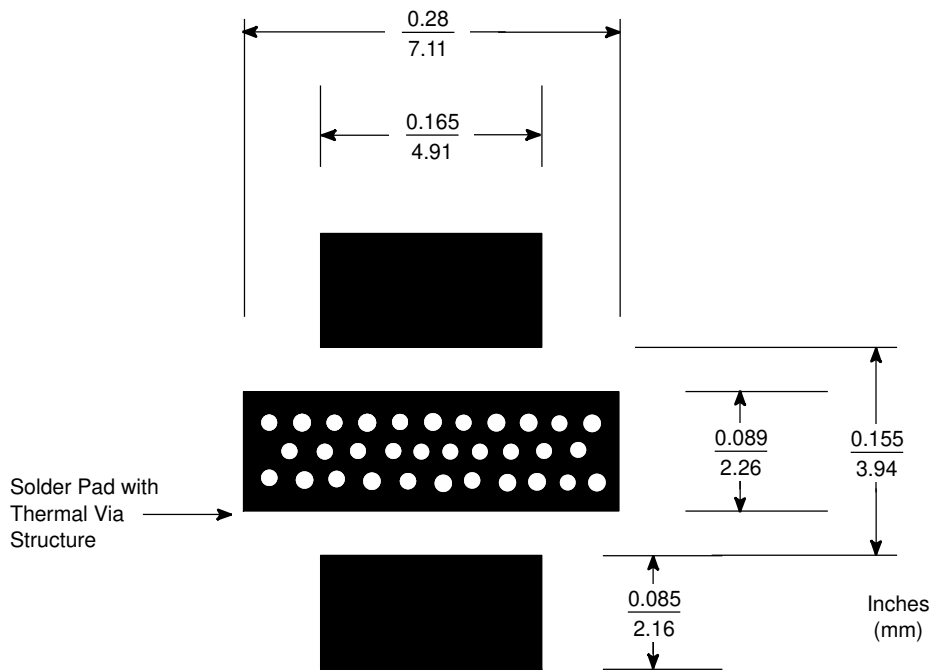

Figure 28. PCB Pad Layout for PLD-1.5W

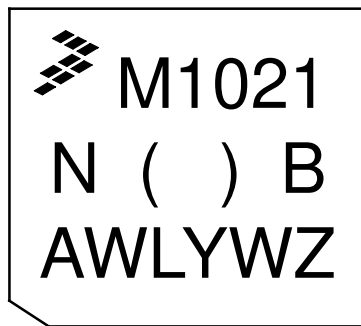
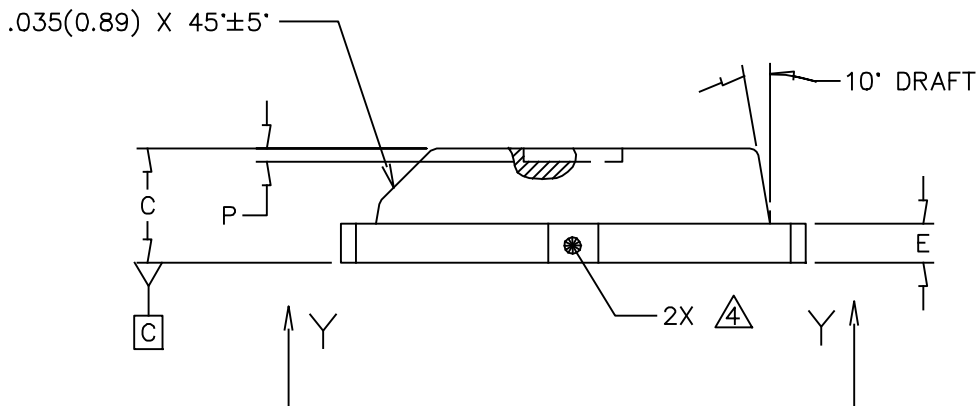
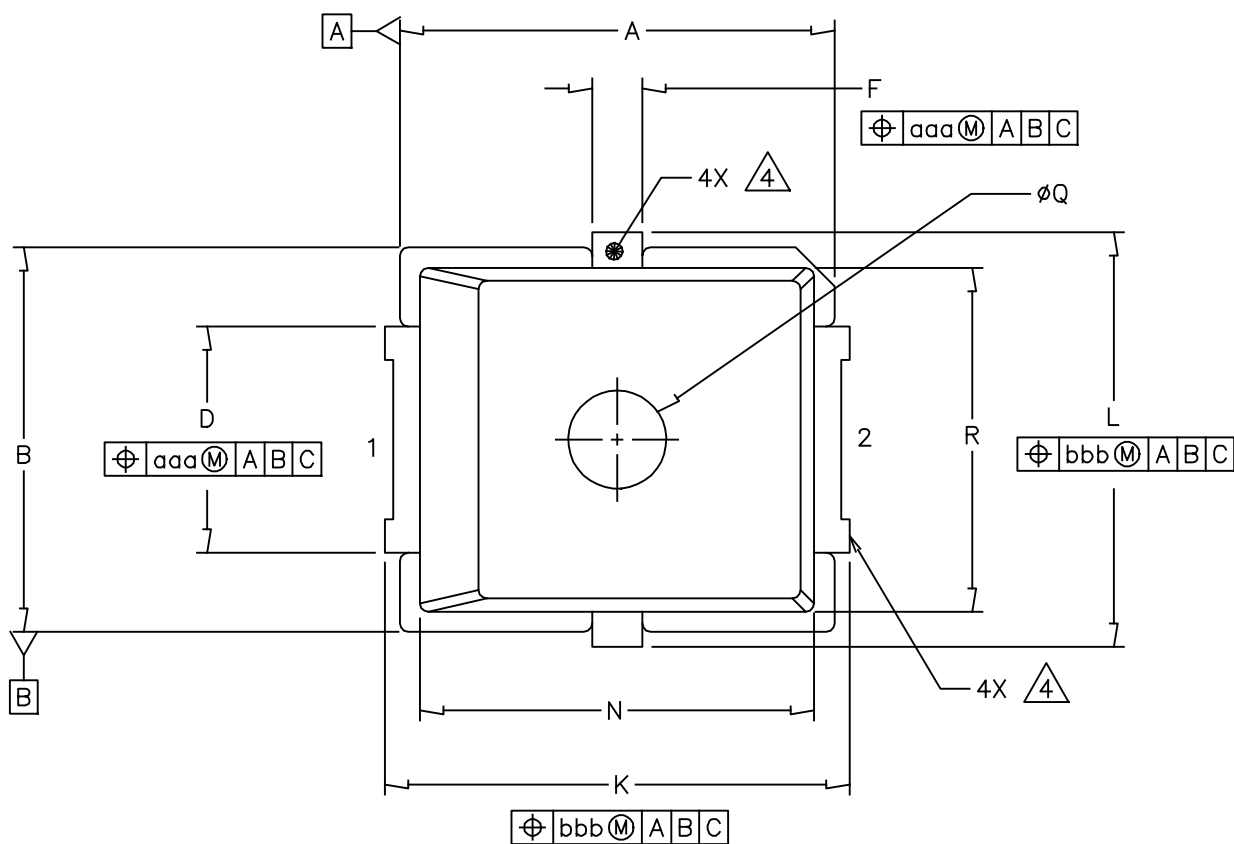
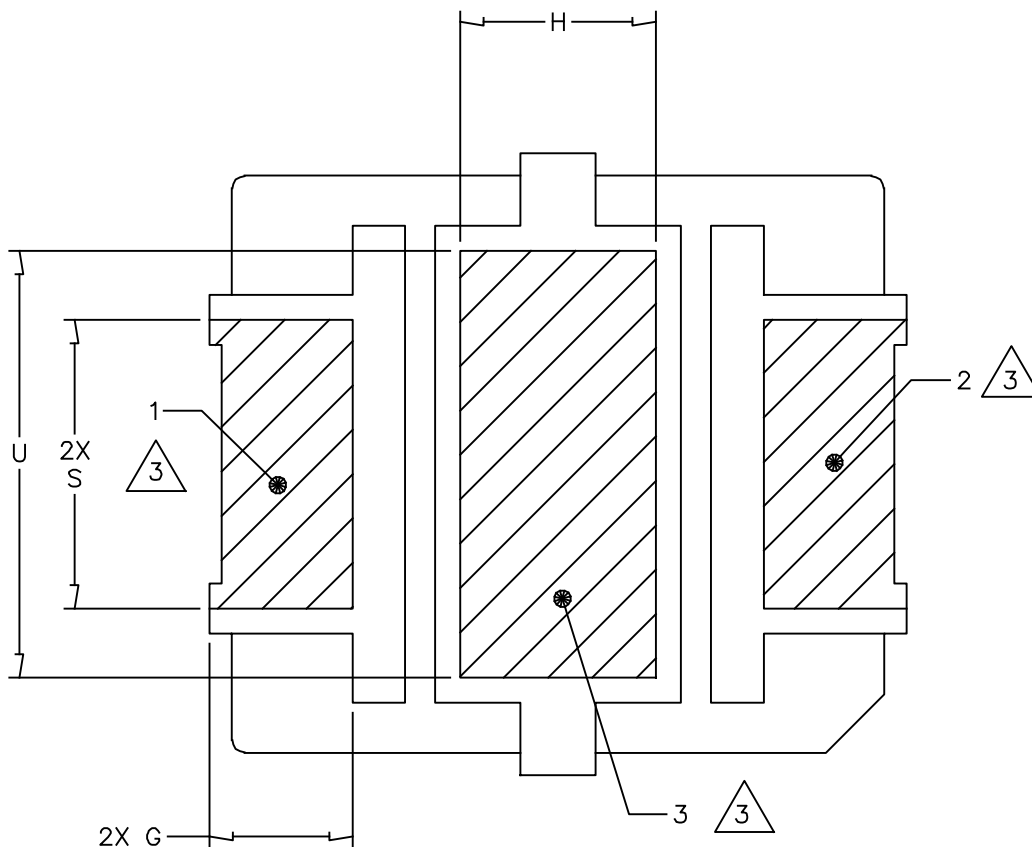

Figure 29. Product Marking

PACKAGE DIMENSIONS



© FREESCALE SEMICONDUCTOR, INC. ALL RIGHTS RESERVED.	MECHANICAL OUTLINE	PRINT VERSION NOT TO SCALE	
TITLE: PLD-1.5W	DOCUMENT NO: 98ASA00476D	REV: 0	
	CASE NUMBER: 2297-01	14 JUN 2012	
	STANDARD: NON-JEDEC		



VIEW Y-Y

© FREESCALE SEMICONDUCTOR, INC. ALL RIGHTS RESERVED.	MECHANICAL OUTLINE	PRINT VERSION NOT TO SCALE	
TITLE: PLD-1.5W	DOCUMENT NO: 98ASA00476D	REV: 0	
	CASE NUMBER: 2297-01	14 JUN 2012	
	STANDARD: NON-JEDEC		