



Chipsmall Limited consists of a professional team with an average of over 10 year of expertise in the distribution of electronic components. Based in Hongkong, we have already established firm and mutual-benefit business relationships with customers from,Europe,America and south Asia,supplying obsolete and hard-to-find components to meet their specific needs.

With the principle of “Quality Parts,Customers Priority,Honest Operation,and Considerate Service”,our business mainly focus on the distribution of electronic components. Line cards we deal with include Microchip,ALPS,ROHM,Xilinx,Pulse,ON,Everlight and Freescale. Main products comprise IC,Modules,Potentiometer,IC Socket,Relay,Connector.Our parts cover such applications as commercial,industrial, and automotives areas.

We are looking forward to setting up business relationship with you and hope to provide you with the best service and solution. Let us make a better world for our industry!



Contact us

Tel: +86-755-8981 8866 Fax: +86-755-8427 6832

Email & Skype: info@chipsmall.com Web: www.chipsmall.com

Address: A1208, Overseas Decoration Building, #122 Zhenhua RD., Futian, Shenzhen, China



MMT10B230T3, MMT10B260T3, MMT10B310T3

Preferred Device

Thyristor Surge Protectors

High Voltage Bidirectional TSPD

These Thyristor Surge Protective devices (TSPD) prevent overvoltage damage to sensitive circuits by lightning, induction and power line crossings. They are breakover-triggered crowbar protectors. Turn-off occurs when the surge current falls below the holding current value.

Secondary protection applications for electronic telecom equipment at customer premises.

Features

- Outstanding High Surge Current Capability: 100 A 10x1000 μ sec Guaranteed at the extended temp range of -20°C to 65°C
- The MMT10B230T3 Series is used to help equipment meet various regulatory requirements including: Bellcore 1089, ITU K.20 & K.21, IEC 950, UL 1459 & 1950 and FCC Part 68.
- Bidirectional Protection in a Single Device
- Little Change of Voltage Limit with Transient Amplitude or Rate
- Freedom from Wearout Mechanisms Present in Non-Semiconductor Devices
- Fail-Safe, Shorts When Overstressed, Preventing Continued Unprotected Operation
- Surface Mount Technology (SMT)
- Complies with GR1089 Second Level Surge Spec at 500 A 2x10 μ sec Waveforms
-  Indicates UL Registered – File #E210057
- Pb-Free Packages are Available



ON Semiconductor®

<http://onsemi.com>

BIDIRECTIONAL TSPD (⚡)
100 AMP SURGE
265 thru 365 VOLTS

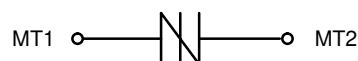

SMB
(No Polarity)
(Essentially JEDEC DO-214AA)
CASE 403C

MARKING DIAGRAMS

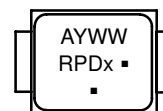

A = Assembly Location
Y = Year
WW = Work Week
RPDx = Device Code
x = F, G, or J
▪ = Pb-Free Package
(Note: Microdot may be in either location)

ORDERING INFORMATION

See detailed ordering and shipping information in the package dimensions section on page 2 of this data sheet.

Preferred devices are recommended choices for future use and best overall value.

MMT10B230T3, MMT10B260T3, MMT10B310T3

MAXIMUM RATINGS (T_J = 25°C unless otherwise noted)

Rating	Symbol	Value	Unit
Off-State Voltage – Maximum MMT10B230T3 MMT10B260T3 MMT10B310T3	V _{DM}	± 170 ± 200 ± 270	V
Maximum Pulse Surge Short Circuit Current Non-Repetitive Double Exponential Decay Waveform (Notes 1 and 2) (–20°C to +65°C) 2 x 10 μsec 10 x 700 μsec 10 x 1000 μsec	I _{PPS1} I _{PPS2} I _{PPS3}	± 500 ± 180 ± 100	A(pk)
Maximum Non-Repetitive Rate of Change of On-State Current Double Exponential Waveform, R = 2.0, L = 1.5 μH, C = 1.67 μF, I _{pk} = 110A	di/dt	± 100	A/μs

Maximum ratings are those values beyond which device damage can occur. Maximum ratings applied to the device are individual stress limit values (not normal operating conditions) and are not valid simultaneously. If these limits are exceeded, device functional operation is not implied, damage may occur and reliability may be affected.

1. Allow cooling before testing second polarity.
2. Measured under pulse conditions to reduce heating.

THERMAL CHARACTERISTICS

Characteristic	Symbol	Max	Unit
Operating Temperature Range Blocking or Conducting State	T _{J1}	–40 to +125	°C
Overload Junction Temperature – Maximum Conducting State Only	T _{J2}	+175	°C
Instantaneous Peak Power Dissipation (I _{pk} = 100 A, 10x1000 μsec @ 25°C)	P _{PK}	4000	W
Maximum Lead Temperature for Soldering Purposes 1/8" from Case for 10 Seconds	T _L	260	°C

ORDERING INFORMATION

Device	Package	Shipping†
MMT10B230T3	SMB	(12mm) Tape & Reel 2500 Units per Reel
MMT10B230T3G	SMB (Pb-Free)	
MMT10B260T3	SMB	
MMT10B260T3G	SMB (Pb-Free)	
MMT10B310T3	SMB	
MMT10B310T3G	SMB (Pb-Free)	

†For information on tape and reel specifications, including part orientation and tape sizes, please refer to our Tape and Reel Packaging Specifications Brochure, BRD8011/D.

MMT10B230T3, MMT10B260T3, MMT10B310T3

ELECTRICAL CHARACTERISTICS (T_J = 25°C unless otherwise noted)

Devices are bidirectional. All electrical parameters apply to forward and reverse polarities.

Characteristic	Symbol	Min	Typ	Max	Unit
Breakover Voltage (Both polarities) (dv/dt = 100 V/μs, I _{SC} = 1.0 A, V _{dc} = 1000 V) (+65°C)	V _(BO)	–	–	265 320 365 290 340 400	V
Breakover Voltage (Both polarities) (f = 60 Hz, I _{SC} = 1.0 A(rms), V _{OC} = 1000 V(rms), R _I = 1.0 kΩ, t = 0.5 cycle) (Note 3) (+65°C)	V _(BO)	–	–	265 320 365 290 340 400	V
Breakover Voltage Temperature Coefficient	dV _(BO) /dT _J	–	0.08	–	%/°C
Breakdown Voltage (I _(BR) = 1.0 mA) Both polarities	V _(BR)	–	190 240 280	–	V
Off State Current (V _{D1} = 50 V) Both polarities (V _{D2} = V _{DM}) Both polarities	I _{D1} I _{D2}	–	–	2.0 5.0	μA
On–State Voltage (I _T = 1.0 A) (PW ≤ 300 μs, Duty Cycle ≤ 2%) (Note 3)	V _T	–	1.53	5.0	V
Breakover Current (f = 60 Hz, V _{DM} = 1000 V(rms), R _S = 1.0 kΩ) Both polarities	I _{BO}	–	260	–	mA
Holding Current (Both polarities) (Note 3) V _S = 500 Volts; I _T (Initiating Current) = ± 1.0 A	I _H	150	270	–	mA
Critical Rate of Rise of Off–State Voltage (Linear waveform, V _D = Rated V _{BR} , T _J = 25°C)	dv/dt	2000	–	–	V/μs
Capacitance (f = 1.0 MHz, 50 Vdc, 1.0 V rms Signal) (f = 1.0 MHz, 2.0 Vdc, 15 mV rms Signal)	C _O	–	65 160	– 200	pF

3. Measured under pulse conditions to reduce heating.

Voltage Current Characteristic of TSPD (Bidirectional Device)

Symbol	Parameter
I _{D1} , I _{D2}	Off State Leakage Current
V _{D1} , V _{D2}	Off State Blocking Voltage
V _{BR}	Breakdown Voltage
V _{BO}	Breakover Voltage
I _{BO}	Breakover Current
I _H	Holding Current
V _{TM}	On State Voltage

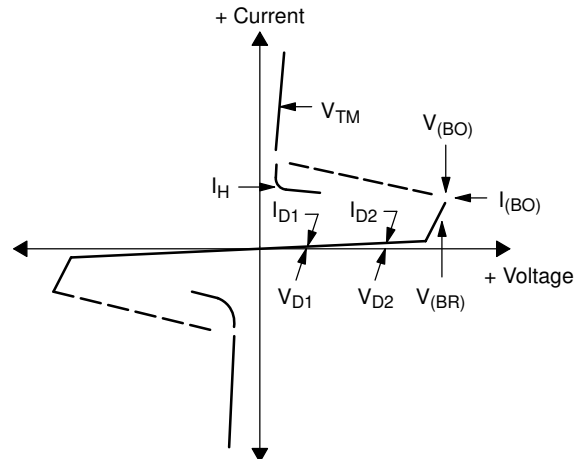

MMT10B230T3, MMT10B260T3, MMT10B310T3

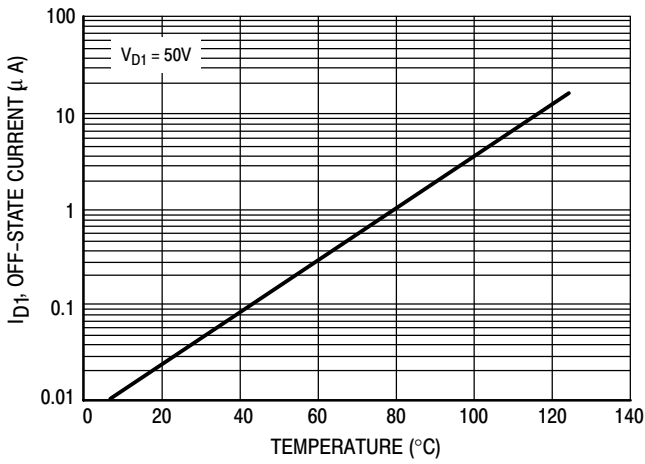

Figure 1. Off-State Current versus Temperature

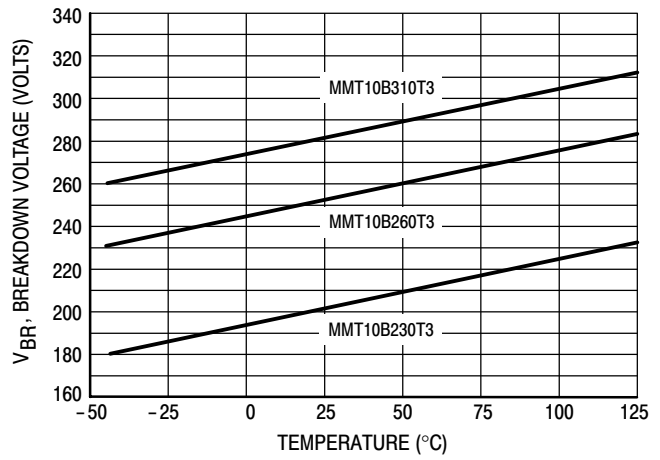

Figure 2. Breakdown Voltage versus Temperature

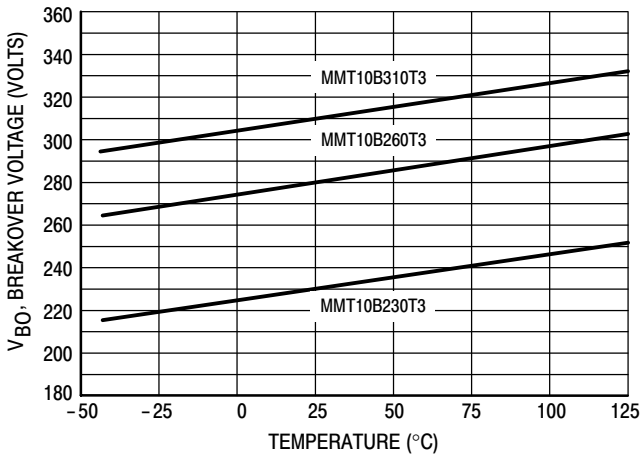

Figure 3. Breakover Voltage versus Temperature

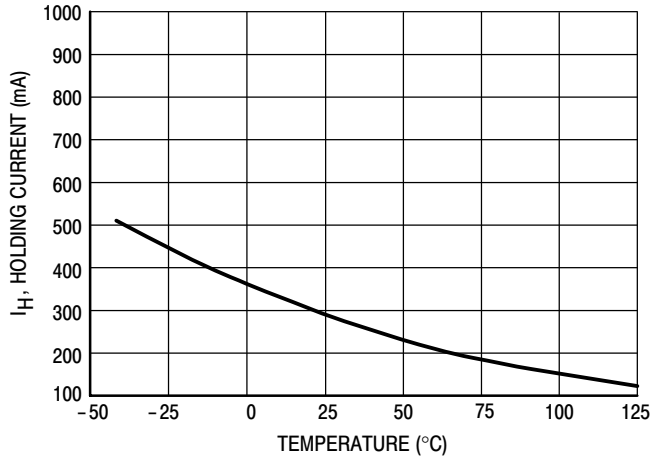

Figure 4. Holding Current versus Temperature

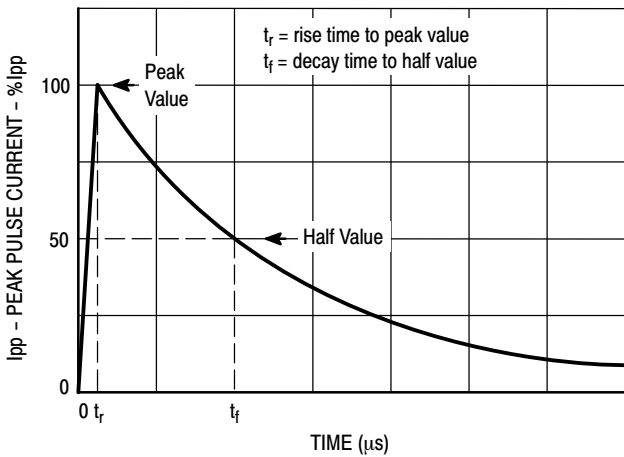

Figure 5. Exponential Decay Pulse Waveform

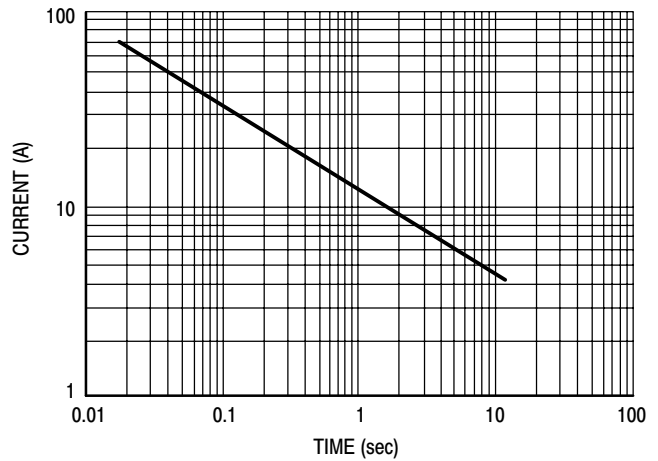
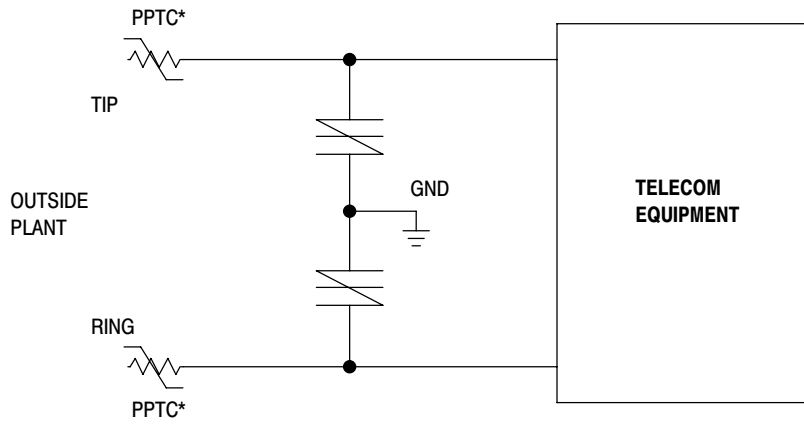
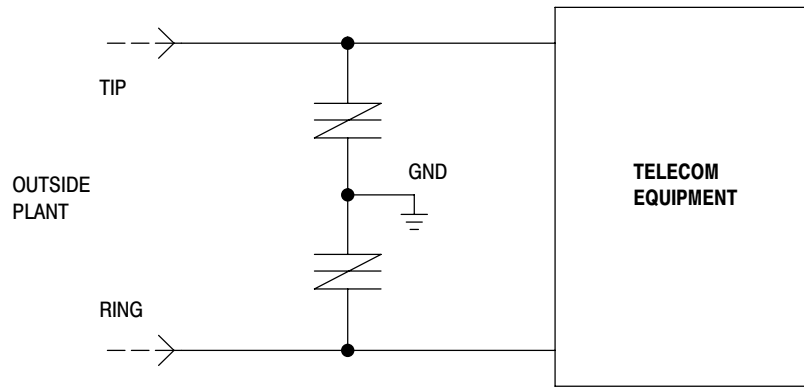
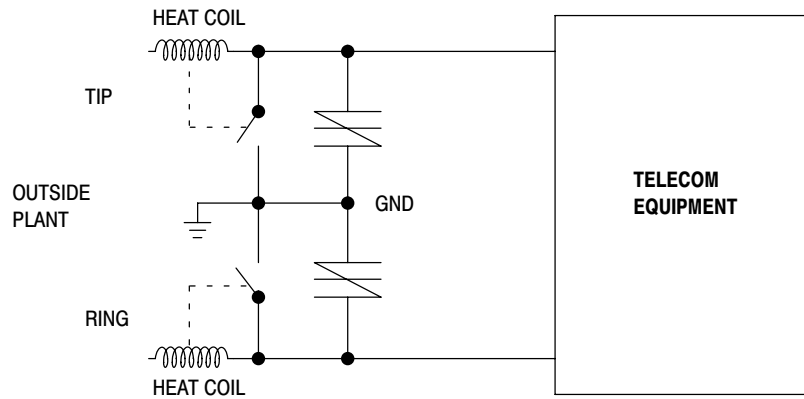

Figure 6. Peak Surge On-State Current versus Surge Current Duration, Sinusoidal Waveform

MMT10B230T3, MMT10B260T3, MMT10B310T3



*Polymeric PTC (positive temperature coefficient) overcurrent protection device



MMT10B230T3, MMT10B260T3, MMT10B310T3

PACKAGE DIMENSIONS

SMB
(No Polarity)
(Essentially JEDEC DO-214AA)
CASE 403C-01
ISSUE A

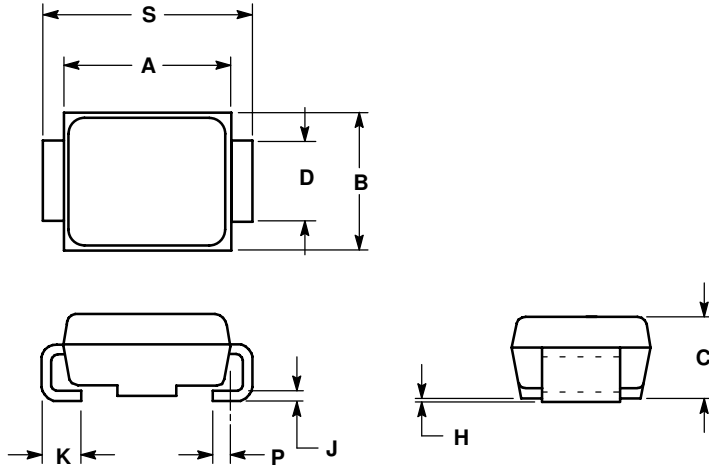

- NOTES:
1. DIMENSIONING AND TOLERANCING PER ANSI Y14.5M, 1982.
 2. CONTROLLING DIMENSION: INCH.
 3. D DIMENSION SHALL BE MEASURED WITHIN DIMENSION P.

DIM	INCHES		MILLIMETERS	
	MIN	MAX	MIN	MAX
A	0.160	0.180	4.06	4.57
B	0.130	0.150	3.30	3.81
C	0.075	0.095	1.90	2.41
D	0.077	0.083	1.96	2.11
H	0.0020	0.0060	0.051	0.152
J	0.006	0.012	0.15	0.30
K	0.030	0.050	0.76	1.27
P	0.020 REF		0.51 REF	
S	0.205	0.220	5.21	5.59

SOLDERING FOOTPRINT*

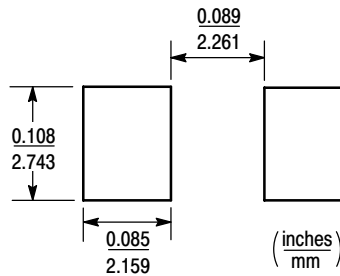

*For additional information on our Pb-Free strategy and soldering details, please download the ON Semiconductor Soldering and Mounting Techniques Reference Manual, SOLDERRM/D.

ON Semiconductor and  are registered trademarks of Semiconductor Components Industries, LLC (SCILLC). SCILLC reserves the right to make changes without further notice to any products herein. SCILLC makes no warranty, representation or guarantee regarding the suitability of its products for any particular purpose, nor does SCILLC assume any liability arising out of the application or use of any product or circuit, and specifically disclaims any and all liability, including without limitation special, consequential or incidental damages. "Typical" parameters which may be provided in SCILLC data sheets and/or specifications can and do vary in different applications and actual performance may vary over time. All operating parameters, including "Typicals" must be validated for each customer application by customer's technical experts. SCILLC does not convey any license under its patent rights nor the rights of others. SCILLC products are not designed, intended, or authorized for use as components in systems intended for surgical implant into the body, or other applications intended to support or sustain life, or for any other application in which the failure of the SCILLC product could create a situation where personal injury or death may occur. Should Buyer purchase or use SCILLC products for any such unintended or unauthorized application, Buyer shall indemnify and hold SCILLC and its officers, employees, subsidiaries, affiliates, and distributors harmless against all claims, costs, damages, and expenses, and reasonable attorney fees arising out of, directly or indirectly, any claim of personal injury or death associated with such unintended or unauthorized use, even if such claim alleges that SCILLC was negligent regarding the design or manufacture of the part. SCILLC is an Equal Opportunity/Affirmative Action Employer. This literature is subject to all applicable copyright laws and is not for resale in any manner.

PUBLICATION ORDERING INFORMATION

LITERATURE FULFILLMENT:
Literature Distribution Center for ON Semiconductor
P.O. Box 61312, Phoenix, Arizona 85082-1312 USA
Phone: 480-829-7710 or 800-344-3860 Toll Free USA/Canada
Fax: 480-829-7709 or 800-344-3867 Toll Free USA/Canada
Email: orderlit@onsemi.com

N. American Technical Support: 800-282-9855 Toll Free
USA/Canada

Japan: ON Semiconductor, Japan Customer Focus Center
2-9-1 Kamimeguro, Meguro-ku, Tokyo, Japan 153-0051
Phone: 81-3-5773-3850

ON Semiconductor Website: <http://onsemi.com>

Order Literature: <http://www.onsemi.com/litorder>

For additional information, please contact your local Sales Representative.