



Chipsmall Limited consists of a professional team with an average of over 10 year of expertise in the distribution of electronic components. Based in Hongkong, we have already established firm and mutual-benefit business relationships with customers from,Europe,America and south Asia,supplying obsolete and hard-to-find components to meet their specific needs.

With the principle of “Quality Parts,Customers Priority,Honest Operation,and Considerate Service”,our business mainly focus on the distribution of electronic components. Line cards we deal with include Microchip,ALPS,ROHM,Xilinx,Pulse,ON,Everlight and Freescale. Main products comprise IC,Modules,Potentiometer,IC Socket,Relay,Connector.Our parts cover such applications as commercial,industrial, and automotives areas.

We are looking forward to setting up business relationship with you and hope to provide you with the best service and solution. Let us make a better world for our industry!



Contact us

Tel: +86-755-8981 8866 Fax: +86-755-8427 6832

Email & Skype: info@chipsmall.com Web: www.chipsmall.com

Address: A1208, Overseas Decoration Building, #122 Zhenhua RD., Futian, Shenzhen, China



Cellular Gateways

General Description

Don't have an existing network connection where you need it most? ALTA Cellular Gateways allow your Monnit Wireless Sensors to communicate with the iMonnit Online Wireless Sensor Monitoring and Notification System via cellular transmission. They are the perfect solution for remote locations, or where an existing internet connection is not an option.

The ALTA Cellular Gateways are based on the latest Dual-band CDMA or 3G wireless protocols and come integrated with Monnit's wireless access point network (WAN) for use with all Monnit wireless sensors.

The ALTA Cellular Gateway is an advanced all wireless M2M gateway that enables fast time-to-market solutions for a wide range of M2M and partner applications as well. Monnit's ALTA Cellular Gateway is specifically designed to respond to the increasing market need for global technology that accommodates a variety of vertical M2M application segments and remote wireless sensor management solutions.

Example Applications

- Remote Location Monitoring
- Shipping and Transportation
- Agricultural Monitoring
- Vacant Property Management
- Vacation Home Property Management
- Construction Site Monitoring
- Data Center Monitoring

ALTA Cellular Gateway Features

- Wireless range of 1,200+ feet through 12+ walls *
- Frequency Hopping Spread Spectrum (FHSS)
- Improved interference immunity
- Encrypt-RF® Security (Diffie-Hellman Key Exchange + AES-128 CBC for sensor data messages)
- 50,000 sensor message memory
- Over the air updates (future proof)
- True plug & play, no hassles for internet configuration set-up
- No PC required for operation
- Low-cost cellular service packages
- Local status LEDs with transmission and online status indicators
- AC power supply
- Optional 24 hour battery backup in event of power outage

* Actual range may vary depending on environment.

Wireless Range Comparison

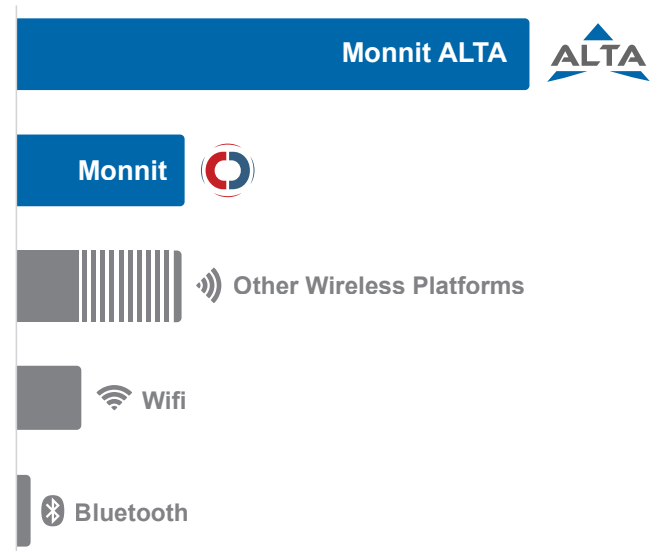

ALTA CDMA Cellular Gateways

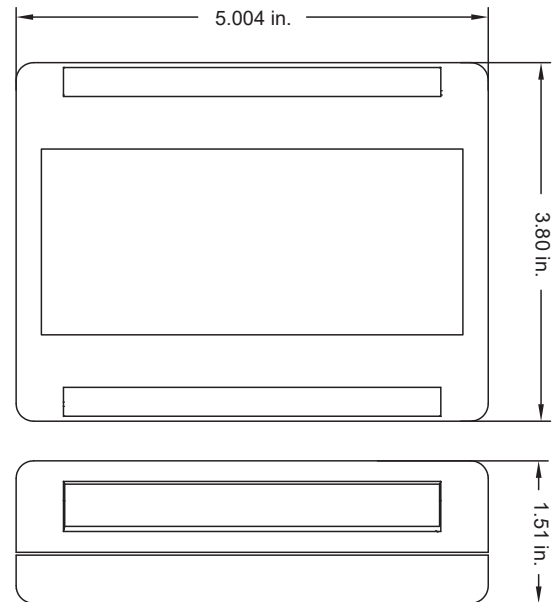

ALTA CDMA Cellular Gateway Specifications

Cellular

Carriers Supported	Verizon Wireless, Sprint Wireless, U.S. Cellular
CDMA	Dual Band CDMA Frequency Range: 800 / 1900 MHz
Antenna	Articulating Dipole, Connector: SMA, Gain (dBi): 1.5

Power

Input Power	5.5 VDC @ 900 mA
Optional Battery Backup	Battery Type: Rechargeable Lithium Polymer
	Battery Duration: Up to 24 hours
	Battery Cycle Life: 500 times

Mechanical

LEDs	Cellular Status LED, Online Status LED, Sensor Network Status LED
Device Memory:	50,000 sensor messages (Sensor messages will be stored in the event of Internet outage and transferred when connection is restored)

Enclosure

	ABS
Dimensions	5.004 x 3.8 x 1.51 in.
Weight	7 ounces



Environmental

Operating Temperature	-10 to +45°C (14 to 113°F)
Storage Temperature	-20 to +60°C (-4 to 140°F)

Wireless

Wireless Range	1,000+ ft. non-line-of-sight
Security	Encrypt-RF™ (256-bit key exchange and AES-128 CTR)

Certifications

	 	
Verizon	FCC: ZTL- G2SC1, FCC: MIVCNN0301	IC: 9794A-G2SC1 and IC: 4160a-CNN0301
Sprint / U.S. Cellular	FCC: ZTL- G2SC1, FCC: RI7CE910-DUAL	IC: 9794A-G2SC1 and IC: 5131A-CE910DUAL

ALTA 3G Cellular Gateways

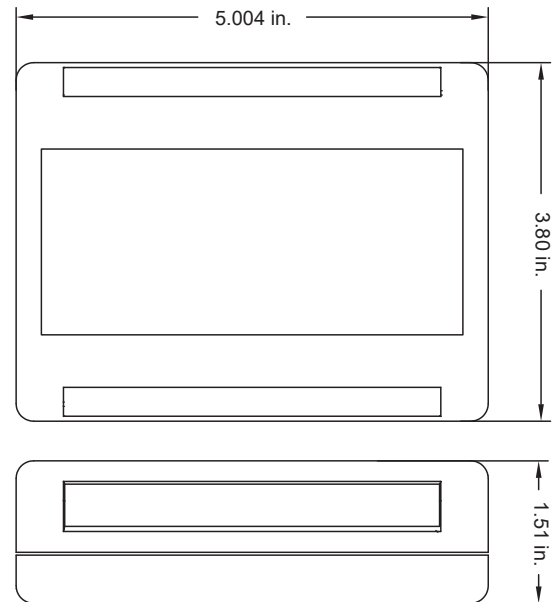

ALTA 3G Cellular Gateway Specifications

Cellular

Cellular Technology	UMTS Frequency Range: 850 / 1700 / 1900 MHz
Antenna	Connector: SMA Gain (dBi): 1.5
SIM Card Compatibility	Mini-SIM (2FF) 25 mm x 15 mm x 0.76 mm

Power

Input Power	5.5 VDC @ 2.5 A
Optional Battery Backup	Battery Type: Rechargeable Lithium Polymer
	Battery Duration: Up to 24 hours
	Battery Cycle Life: 500 times

Mechanical

LEDs	Cellular Status LED, Online Status LED, Sensor Network Status LED
Device Memory:	50,000 sensor messages (Sensor messages will be stored in the event of Internet outage and transferred when connection is restored)

Enclosure

Dimensions	5.004 x 3.8 x 1.51 in.
Weight	7 ounces

Environmental

Operating Temperature	-10 to +45°C (14 to 113°F)
Storage Temperature	-20 to +60°C (-4 to 140°F)

Wireless

Wireless Range	1,000+ ft. non-line-of-sight
Security	Encrypt-RF™ (256-bit key exchange and AES-128 CTR)
Certifications	 FCC: ZTL- G2SC1, FCC: RI7HE910 IC: 9794A-G2SC1 and IC: 5131A-HE910

ALTA Industrial CDMA Cellular Gateways

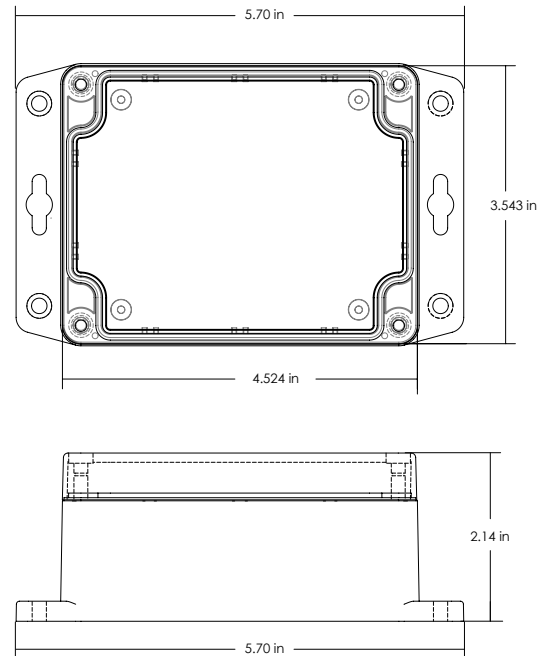

ALTA Industrial CDMA Cellular Gateway Specifications

Cellular

Carriers Supported	Verizon Wireless, Sprint Wireless, U.S. Cellular
CDMA	Dual Band CDMA Frequency Range: 800 / 1900 MHz
Antenna	Articulating Dipole, Connector: SMA, Gain (dBi): 1.5

Power

Input Power	5.5 VDC @ 900 mA (rated for outdoor use)
-------------	--

Mechanical

LEDs	Cellular Status LED, Online Status LED, Sensor Network Status LED
Device Memory:	50,000 sensor messages (messages will be stored in the event of Internet outage and transferred when connection is restored).
Enclosure	NEMA 1, 2, 4, 4x, 12 and 13 rated, sealed and weather proof Monnit's NEMA rated enclosures are constructed for both indoor or outdoor use and protect the enclosed circuitry against the ingress of solid foreign objects like dust as well as the damaging effects of water (rain, sleet, snow, splashing water, and hose directed water).
Dimensions	5.70 x 3.543 x 2.14 in.
Weight	12 ounces

Environmental

Operating Temperature	-10 to +45°C (14 to 113°F)
Storage Temperature	-20 to +60°C (-4 to 140°F)

Wireless

Wireless Range	1,000+ ft. non-line-of-sight
Security	Encrypt-RF™ (256-bit key exchange and AES-128 CTR)

Certifications

Verizon	FCC: ZTL- G2SC1, FCC: MIVCNN0301	IC: 9794A-G2SC1 and IC: 4160a-CNN0301
Sprint / U.S. Cellular	FCC: ZTL- G2SC1, FCC: RI7CE910-DUAL	IC: 9794A-G2SC1 and IC: 5131A-CE910DUAL

ALTA Industrial 3G Cellular Gateways

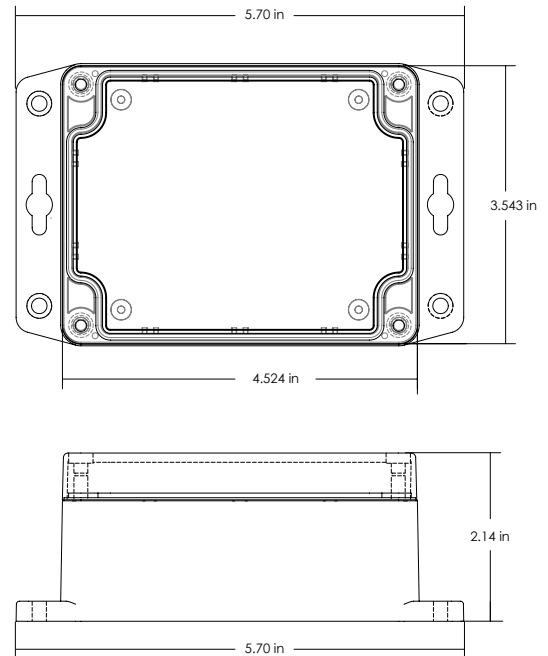

ALTA Industrial 3G Cellular Gateway Specifications

Cellular

Cellular Technology	UMTS Frequency Range: 850 / 1700 / 1900 MHz
Antenna	Connector: SMA Gain (dBi): 1.5
SIM Card Compatibility	Mini-SIM (2FF) 25 mm x 15 mm x 0.76 mm

Power

Input Power	5.5 VDC @ 2.5 A (rated for outdoor use)
-------------	---

Mechanical

LEDs	Cellular Status LED, Online Status LED, Sensor Network Status LED
Device Memory:	50,000 sensor messages (messages will be stored in the event of Internet outage and transferred when connection is restored).
Enclosure	NEMA 1, 2, 4, 4x, 12 and 13 rated, sealed and weather proof Monnit's NEMA rated enclosures are constructed for both indoor or outdoor use and protect the enclosed circuitry against the ingress of solid foreign objects like dust as well as the damaging effects of water (rain, sleet, snow, splashing water, and hose directed water).
Dimensions	5.70 x 3.543 x 2.14 in.
Weight	12 ounces

Environmental

Operating Temperature	-10 to +45°C (14 to 113°F)
Storage Temperature	-20 to +60°C (-4 to 140°F)

Wireless

Wireless Range	1,000+ ft. non-line-of-sight
Security	Encrypt-RF™ (256-bit key exchange and AES-128 CTR)

Certifications	 FCC: ZTL- G2SC1, FCC: RI7HE910 IC: 9794A-G2SC1 and IC: 5131A-HE910
----------------	---

Commercial Grade Cellular Gateways:

Monnit commercial grade cellular gateways are designed for applications in ordinary environments (normal room temperature, humidity and atmospheric pressure). Do not use these gateways under the following conditions as these factors can deteriorate the product characteristics and cause failures and burn-out.

- Corrosive gas or deoxidizing gas - chlorine gas, hydrogen sulfide gas, ammonia gas, sulfuric acid gas, nitric oxides gas, etc.).
- Volatile or flammable gas.
- Dusty conditions.
- Under low or high pressure.
- Wet or excessively humid locations.
- Places with salt water, oils chemical liquids or organic solvents.
- Where there are excessively strong vibrations.
- Other places where similar hazardous conditions exist.

Use these product within the specified temperature range. Higher temperature may cause deterioration of the characteristics or the material quality.

Industrial Grade Cellular Gateways - Type 1, 2, 4, 4X, 12 and 13 NEMA Rated Enclosure:

Monnit's Industrial cellular gateways are enclosed in reliable, weatherproof NEMA rated enclosures. Our NEMA rated enclosures are constructed for both indoor or outdoor use and protect the sensor circuitry against the ingress of solid foreign objects like dust as well as the damaging effects of water (rain, sleet, snow, splashing water, and hose directed water).

- Safe from falling dirt.
- Protects against wind blown dust.
- Protects against rain, sleet, snow, splashing water, and hose directed water
- Increased level of corrosion resistance
- Will remain undamaged by ice formation on the enclosure



For more information about our products or to place an order, please contact our sales department at 801-561-5555.

Visit us on the web at www.monnit.com.

Monnit Corporation
3400 South West Temple
South Salt Lake, UT 84115
801-561-5555
www.monnit.com