



Chipsmall Limited consists of a professional team with an average of over 10 year of expertise in the distribution of electronic components. Based in Hongkong, we have already established firm and mutual-benefit business relationships with customers from,Europe,America and south Asia,supplying obsolete and hard-to-find components to meet their specific needs.

With the principle of “Quality Parts,Customers Priority,Honest Operation,and Considerate Service”,our business mainly focus on the distribution of electronic components. Line cards we deal with include Microchip,ALPS,ROHM,Xilinx,Pulse,ON,Everlight and Freescale. Main products comprise IC,Modules,Potentiometer,IC Socket,Relay,Connector.Our parts cover such applications as commercial,industrial, and automotives areas.

We are looking forward to setting up business relationship with you and hope to provide you with the best service and solution. Let us make a better world for our industry!



Contact us

Tel: +86-755-8981 8866 Fax: +86-755-8427 6832

Email & Skype: info@chipsmall.com Web: www.chipsmall.com

Address: A1208, Overseas Decoration Building, #122 Zhenhua RD., Futian, Shenzhen, China



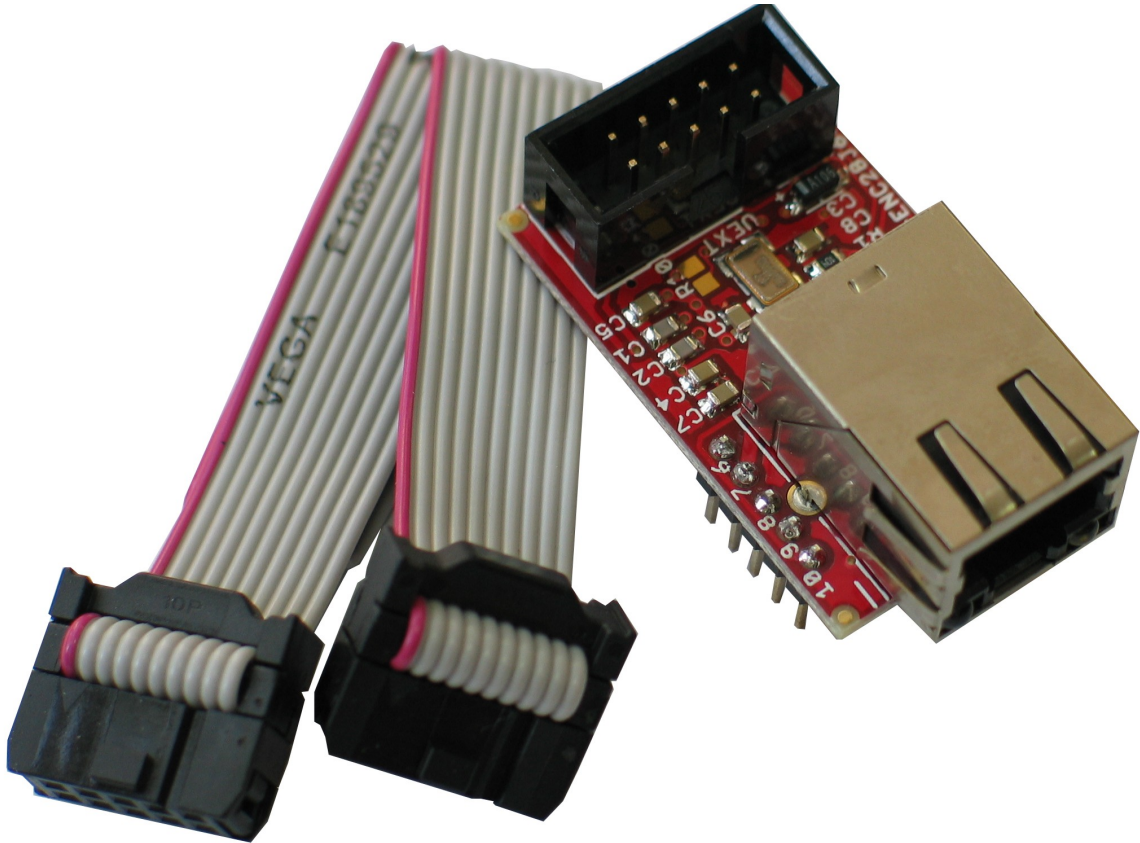

MOD-ENC28J60 development board

User's manual



All boards produced by Olimex are ROHS compliant

Document revision B, January 2015
Copyright(c) 2015, OLIMEX Ltd, All rights reserved

INTRODUCTION

MOD-ENC28J60 is development board with UEXT connector and 10 Mbit ENC28J60 ethernet controller from Microchip Technology Inc.

BOARD FEATURES

- MOD-ENC28J60 is the easiest way to add 10 Mbit ethernet connectivity to any of our boards with UEXT connector
- ENC28J60 Ethernet controller with UEXT connector for easy connection to our other development boards with UEXT connector
- LAN connector with build in transformer
- two status LEDs on LAN connector
- SPI interface takes only few pins to add Ethernet interface to your microcontroller project
- UEXT 10 pin interface on 0.1" row pins header
- backward compatibility with ENC28J60-H with 2×5 pin header
- PCB: FR-4, 1.5 mm (0,062"), soldermask, white silkscreen component print
- Dimensions: 40×24 mm (1.55×0.95")
- space between the pin rows: 20 mm (0.8")

ELECTROSTATIC WARNING

The MOD-ENC28J60 board is shipped in protective anti-static packaging. The board must not be subject to high electrostatic potentials. General practice for working with static sensitive devices should be applied when working with this board.

BOARD USE REQUIREMENTS

Hardware: Our development boards [PIC-WEB](#) and [PIC-MINI-WEB](#) use ENC28J60

Ethernet Controller Features

MOD-ENC28J60 board use ENC28J60 stand-alone ethernet controller with these features:

- IEEE 802.3. Compatible Ethernet Controller
- Fully Compatible with 10/100/1000Base-T Networks
- Integrated MAC and 10Base-T PHY
- Supports One 10Base-T Port with Automatic Polarity Detection and Correction
- Supports Full and Half-Duplex modes
- Programmable Automatic Retransmit on Collision
- Programmable Padding and CRC Generation
- Programmable Automatic Rejection of Erroneous Packets
- SPI Interface with Clock Speeds Up to 20 MHz

BLOCK DIAGRAM

ENC28J60 BLOCK DIAGRAM

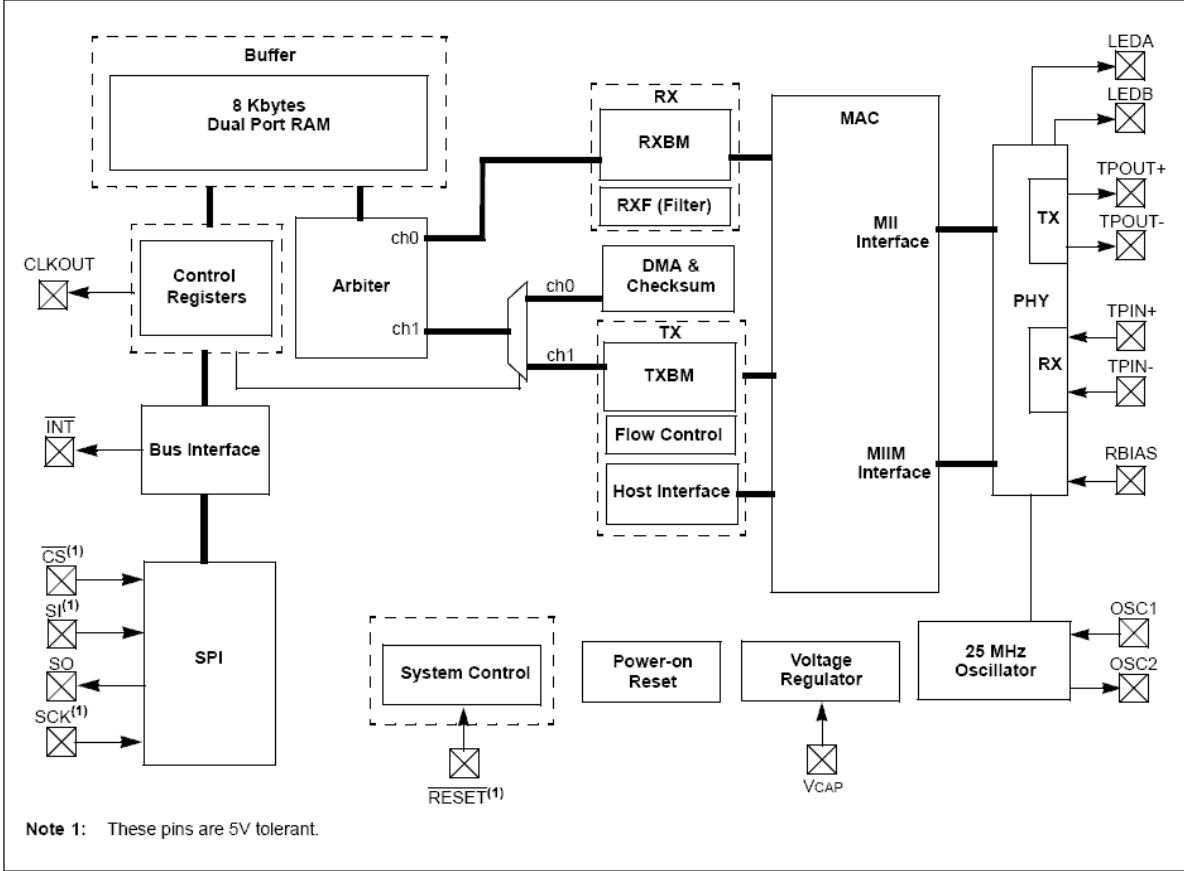

MEMORY MAP

ENC28J60 MEMORY ORGANIZATION

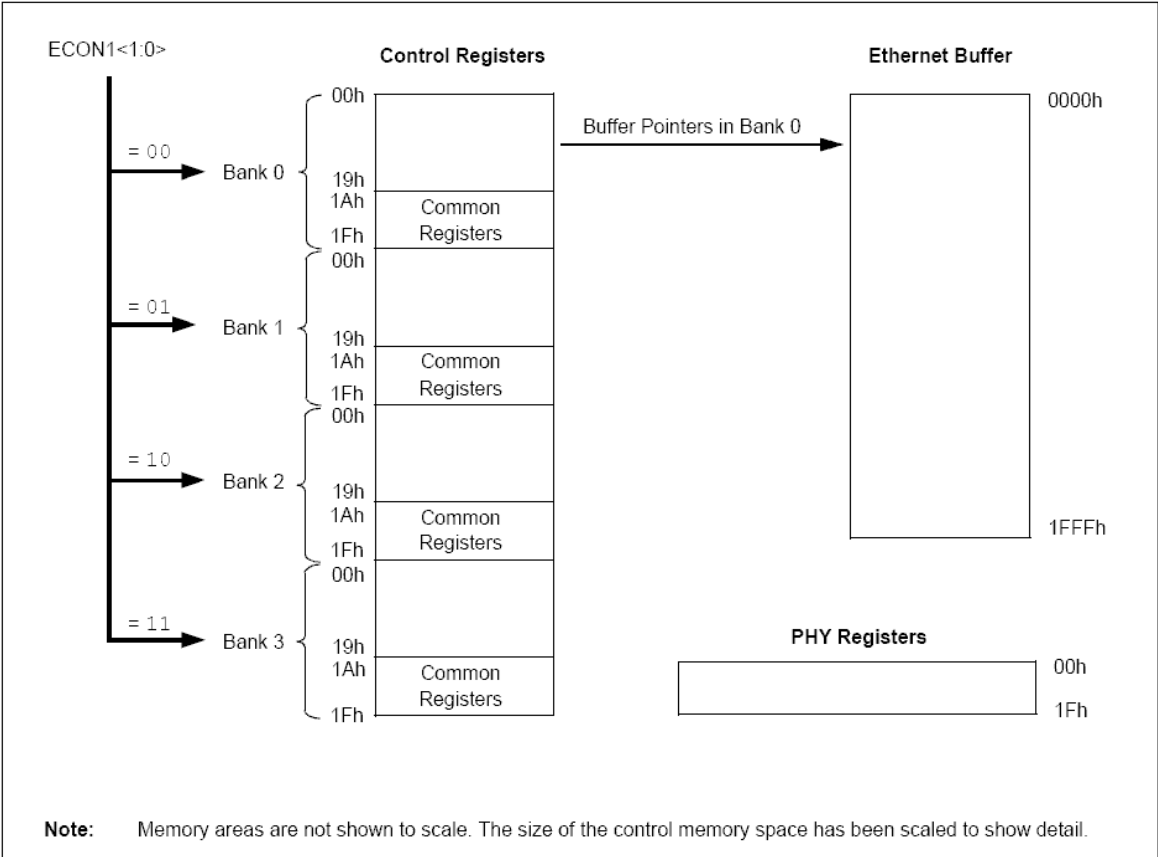

SCHEMATIC

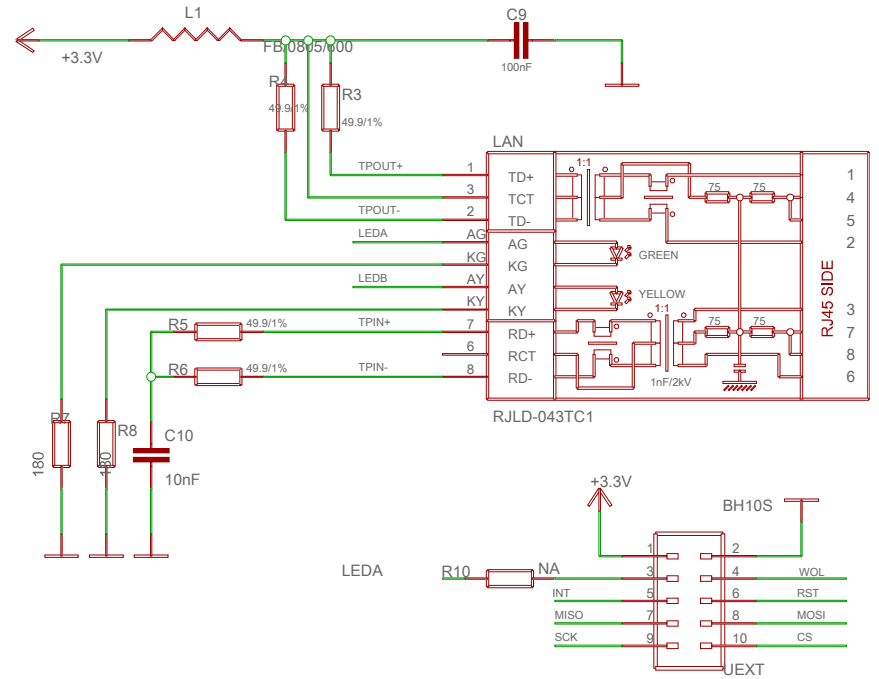
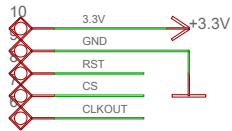
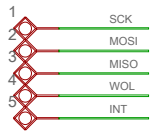
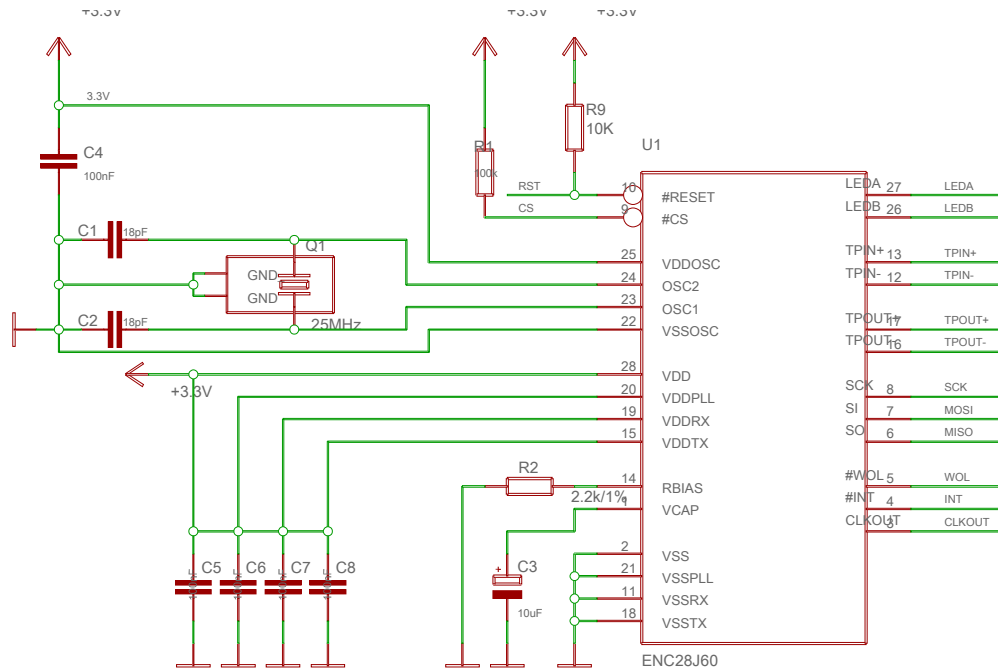

MOD-ENC28J60, board revision A

OLIMEX LTD, BULGARIA

<https://www.olimex.com>

BOARD LAYOUT

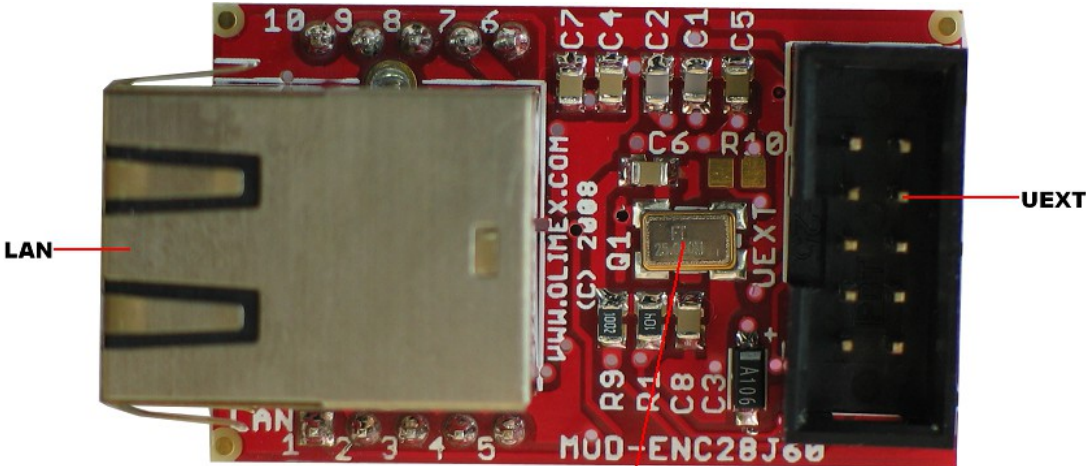

Quartz Crystal Q1

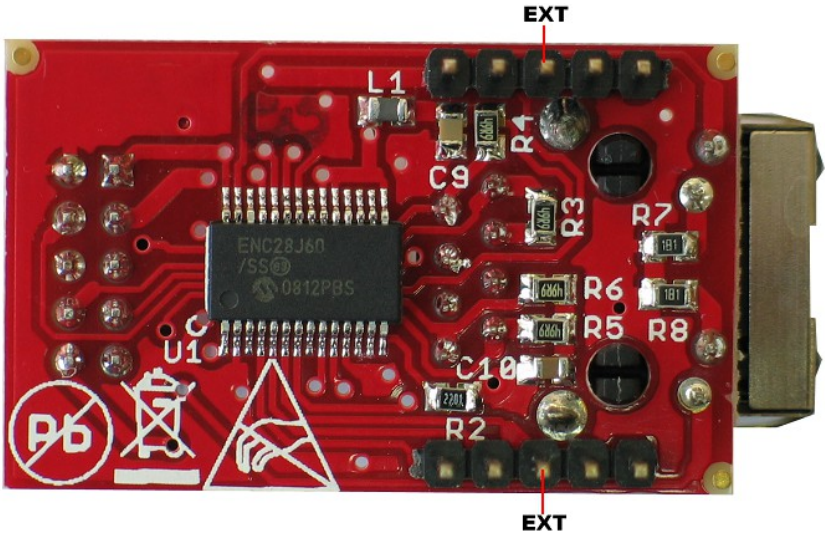

POWER SUPPLY CIRCUIT

MOD-ENC28J60 is typically power supplied by UEXT pin 1 and pin 2 and by EXT pin 10 and pin 9.

RESET CIRCUIT

MOD-ENC28J60 reset circuit includes pin 6 of UEXT connector, pin 10 of U1 and R9 (10k).

CLOCK CIRCUIT

Quartz crystal 25 MHz is connected to ENC28J60 pin 23 (OSC1) and pin24 (OSC2).

IMPORTANT: If the board has a quartz crystal rotated at 45 degrees relative to the pads provided do not panic. This is normal. We have two types of such crystals - one of them requires 4 pads, the other only 2 pads. That is why we have provided 4 pads to be able to fit both crystals. All boards Olimex manufactures pass automatized optical inspection after assembly and obvious misplacement like this is impossible to occur.

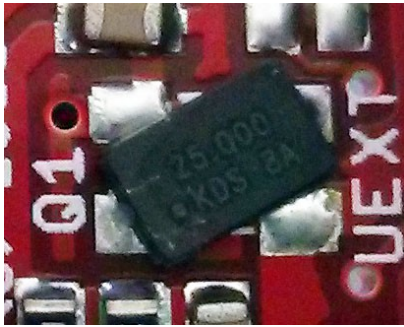

A tilted quartz crystal is not a sign of a manufacturing error!

JUMPER DESCRIPTION

There are no jumpers on the board.

CONNECTOR DESCRIPTIONS

UEXT

Pin #	Signal Name
1	3.3V
2	GND
3	LEDA
4	WOL
5	INT
6	RST
7	MISO
8	MOSI
9	SCK
10	CS

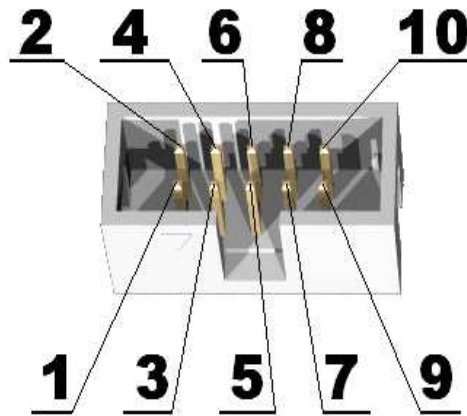

LAN

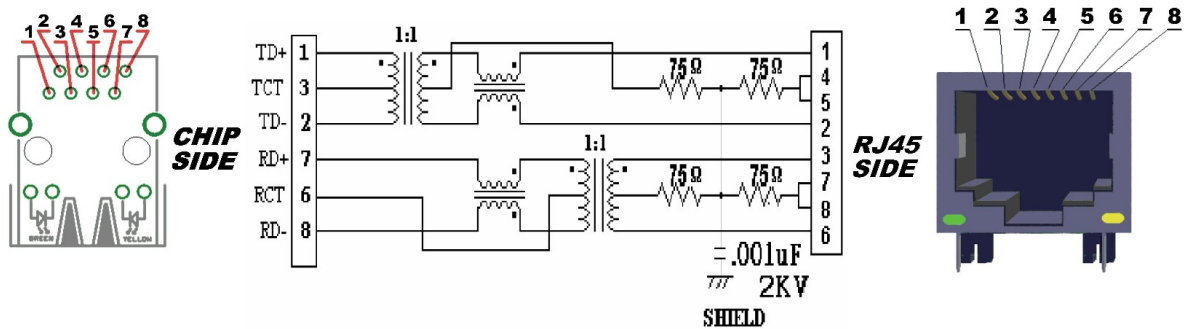

Pin #	Signal Name Chip Side	Pin #	Signal Name Chip Side
1	TX+	5	Not Connected (NC)
2	TX-	6	VDD
3	VDD	7	RX+
4	Not Connected (NC)	8	RX-

LED	Color	Usage
Right	Green	Link status
Left	Yellow	Activity status

EXT

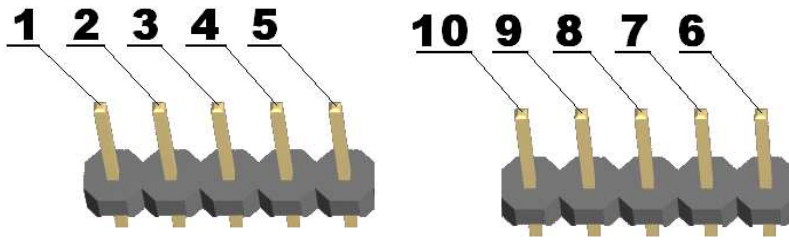

Pin#	Signal Name	Pin#	Signal Name
1	SCK	6	CLKOUT
2	MOSI	7	CS
3	MISO	8	RST
4	WOL	9	GND
5	INT	10	3.3V

MECHANICAL DIMENSIONS

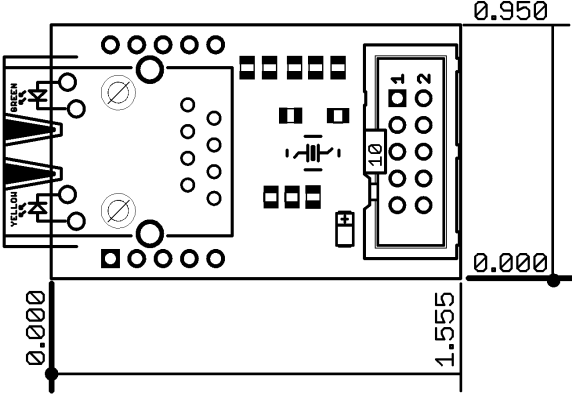

All measures are in inches.

AVAILABLE DEMO SOFTWARE

Please check the SOFTWARE section of the product page for a number of examples with different boards. The web page for MOD-ENC28J60 is:

<https://www.olimex.com/Products/Modules/Ethernet/MOD-ENC28J60/>

ORDER CODE

MOD-ENC28J60 – completely assembled and tested, includes ENC28J60 Ethernet controller

How to order?

You can purchase directly from our online shop or from any of our distributors. Note that usually it might be faster and cheaper to purchase Olimex products from our distributors. List of confirmed Olimex LTD distributors and resellers: <https://www.olimex.com/Distributors>

Please visit our web site www.olimex.com for more information.

REVISION HISTORY:

Board revision:

Board revision	Notable changes
B	Initial release of the board

Manual revision:

Document revision	Notable changes	Modified page
A	- Initial manual release	All
B, 23.01.15	- Cleared duplicate information - Added clarification about the rotated quartz crystal - Formatting improvements	All

Disclaimer:

© 2015 Olimex Ltd. Olimex®, logo and combinations thereof, are registered trademarks of Olimex Ltd. Other product names may be trademarks of others and the rights belong to their respective owners.

The information in this document is provided in connection with Olimex products. No license, express or implied or otherwise, to any intellectual property right is granted by this document or in connection with the sale of Olimex products.

The hardware design of MOD-ENC28J60 is considered intellectual property of Olimex. The hardware design files are considered copyright material and would not be distributed.

It is possible that the pictures in this manual differ from the latest revision of the board.

The product described in this document is subject to continuous development and improvements. All particulars of the product and its use contained in this document are given by OLIMEX in good faith. However all warranties implied or expressed including but not limited to implied warranties of merchantability or fitness for purpose are excluded. This document is intended only to assist the reader in the use of the product. OLIMEX Ltd. shall not be liable for any loss or damage arising from the use of any information in this document or any error or omission in such information or any incorrect use of the product.

This evaluation board/kit is intended for use for engineering development, demonstration, or evaluation purposes only and is not considered by OLIMEX to be a finished end-product fit for general consumer use. Persons handling the product must have electronics training and observe good engineering practice standards. As such, the goods being provided are not intended to be complete in terms of required design-, marketing-, and/or manufacturing-related protective considerations, including product safety and environmental measures typically found in end products that incorporate such semiconductor components or circuit boards.

Olimex currently deals with a variety of customers for products, and therefore our arrangement with the user is not exclusive. Olimex assumes no liability for applications assistance, customer product design, software performance, or infringement of patents or services described herein.

THERE IS NO WARRANTY FOR THE DESIGN MATERIALS AND THE COMPONENTS USED TO CREATE MOD-ENC28J60. THEY ARE CONSIDERED SUITABLE ONLY FOR MOD-ENC28J60.