



Chipsmall Limited consists of a professional team with an average of over 10 year of expertise in the distribution of electronic components. Based in Hongkong, we have already established firm and mutual-benefit business relationships with customers from,Europe,America and south Asia,supplying obsolete and hard-to-find components to meet their specific needs.

With the principle of “Quality Parts,Customers Priority,Honest Operation,and Considerate Service”,our business mainly focus on the distribution of electronic components. Line cards we deal with include Microchip,ALPS,ROHM,Xilinx,Pulse,ON,Everlight and Freescale. Main products comprise IC,Modules,Potentiometer,IC Socket,Relay,Connector.Our parts cover such applications as commercial,industrial, and automotives areas.

We are looking forward to setting up business relationship with you and hope to provide you with the best service and solution. Let us make a better world for our industry!



Contact us

Tel: +86-755-8981 8866 Fax: +86-755-8427 6832

Email & Skype: info@chipsmall.com Web: www.chipsmall.com

Address: A1208, Overseas Decoration Building, #122 Zhenhua RD., Futian, Shenzhen, China



DESCRIPTION

The MP3309A is a WLED step-up converter for 2.7V-to-5.5V input that uses peak-current mode to regulate the LED current sensed through an external low-side resistor. The 200mV feedback voltage and synchronous rectification reduces power loss and reduces PCB space requirements. To connect an external Schottky accomplishes the non-synchronous mode for heavy load to improve the thermal performance.

The MP3309A features a programmable switching frequency to optimize efficiency. It supports both analog and PWM dimming.

In addition, the MP3309A has LED open protection, cycle-by-cycle current limit protection, thermal shutdown protection and over-voltage protection. MP3309A is available in QFN10 3*3mm package.

FEATURES

- 2.7V-to-5.5V Input Voltage
- Low 200mV Feedback Voltage with $\pm 1\%$ Accuracy
- Synchronous Mode
- Analog and PWM Dimming
- Programmable Switching Frequency
- 35.5V Over Voltage Protection Point
- Hardware-Enable Function
- UVLO, Thermal Shutdown
- Available in 3x3mm QFN10 Package

APPLICATIONS

- Feature Phones and Smart Phones
- Tablets
- Video Displays

All MPS parts are lead-free and adhere to the RoHS directive. For MPS green status, please visit MPS website under Products, Quality Assurance page. "MPS" and "The Future of Analog IC Technology" are Registered Trademarks of Monolithic Power Systems, Inc.

TYPICAL APPLICATION

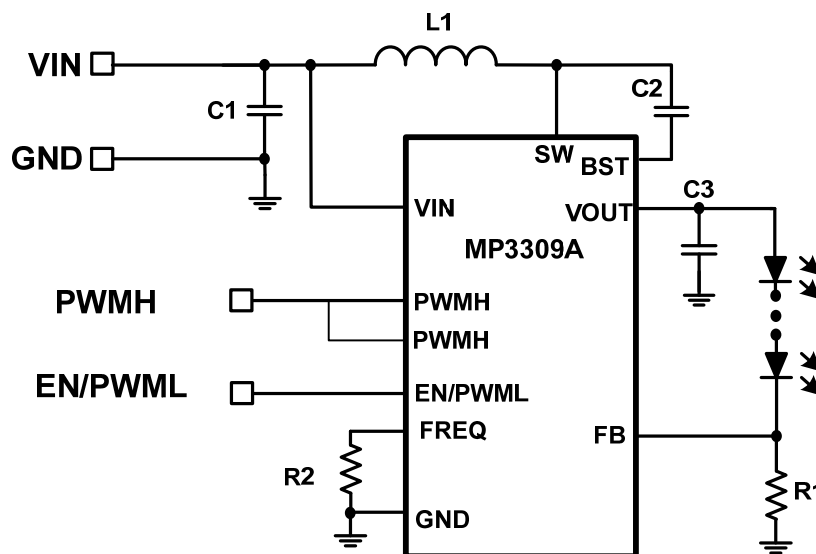

ORDERING INFORMATION

Part Number	Package	Top Marking
MP3309AGQ*	QFN10 (3x3mm)	AJFY

* For Tape & Reel, add suffix -Z (e.g. MP3309AGQ-Z);

PACKAGE REFERENCE

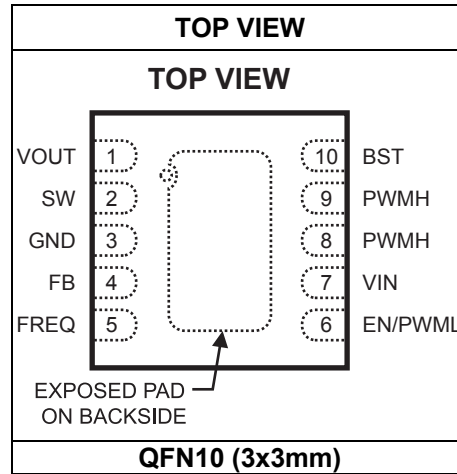

ABSOLUTE MAXIMUM RATINGS ⁽¹⁾

V_{IN}	-0.3V to +6V
V_{SW}, V_{OUT}	-1V to +40V
V_{BST}	-0.3V to $V_{SW} + 6V$
All Other Pins	-0.3V to +6V
Junction Temperature	150°C
Lead Temperature	260°C
Continuous Power Dissipation ($T_A = 25^\circ C$) ⁽²⁾	
QFN10(3x3mm)	2.5W

Recommended Operating Conditions ⁽³⁾

Supply Voltage V_{IN}	2.7V to 5.5V
Operating Junction Temp. (T_J).	-40°C to +125°C

Thermal Resistance ⁽⁴⁾	θ_{JA}	θ_{JC}
QFN10 (3x3mm)	50	12 °C/W

Notes:

- Exceeding these ratings may damage the device.
- The maximum allowable power dissipation is a function of the maximum junction temperature T_J (MAX), the junction-to-ambient thermal resistance θ_{JA} , and the ambient temperature T_A . The maximum allowable continuous power dissipation at any ambient temperature is calculated by P_D (MAX) = $(T_J$ (MAX) - T_A) / θ_{JA} . Exceeding the maximum allowable power dissipation will cause excessive die temperature, and the regulator will go into thermal shutdown. Internal thermal shutdown circuitry protects the device from permanent damage.
- The device is not guaranteed to function outside of its operating conditions.
- Measured on JESD51-7, 4-layer PCB.

ELECTRICAL CHARACTERISTICS

$V_{IN} = 3.6V$, $V_{EN} = V_{IN}$, $T_A = 25^{\circ}C$, unless otherwise noted.

Parameters	Symbol	Condition	Min	Typ	Max	Units
STEP-UP CONVERTER						
Operating Input Voltage	V_{IN}		2.7		5.5	V
Supply Current (Quiescent)	I_Q	$V_{IN}=3.6V$, $V_{EN}=V_{IN}$, no load with switching		420		μA
Supply Current (Shutdown)	I_{ST}	$V_{EN}=0V$, $V_{IN}=3.6V$			1	μA
Input UVLO Threshold	V_{IN_UVLO}	Rising Edge		2.5		V
Input UVLO Hysteresis				200		mV
EN High Voltage	V_{EN_HIGH}	V_{EN} Rising	1.2			V
EN Low Voltage	V_{EN_LOW}	V_{EN} Falling			0.4	V
Switching Frequency	f_{SW}	$R_{FREQ} = 200k\Omega$	540	640	740	kHz
Maximum Duty Cycle	D_{MAX}	Sync Mode, 640kHz	89	93		%
Feedback Regulation Voltage	V_{REF}		198	200	202	mV
POWER SWITCH						
Main Switch On-Resistance	R_{DSON_M}	$V_{IN}=3.6V$		0.3	0.5	Ω
Sync Switch On-Resistance	R_{DSON_S}	$V_{IN}=3.6V$		0.5	0.8	Ω
CURRENT DIMMING						
PWMH Input Low Threshold	V_{PWM_LO}	V_{PWM} Falling			0.4	V
PWMH Input High Threshold	V_{PWM_HI}	V_{PWM} Rising	1.2			V
PWML Shutdown Time	t_{SD}	EN/PWML High to Low		20		ms
PROTECTION						
OVP Voltage	V_{OVP}		33.5	35.5	37.5	V
		Hysteresis		2.5		V
Cycle-Cycle Current Limit	I_{LIM}	Max Duty Cycle	1.4	1.8		A
Startup Current Limit	I_{LIM_START}	Max Duty Cycle		0.8		A
Time Step for Half Current Limit	T_{LIM_HALF}			5		ms
OVP UVLO Threshold	V_{OVP_UV}			1.24		V
Thermal Shutdown Threshold	t_{ST}			150		$^{\circ}C$
Thermal Shutdown Hysteresis				25		$^{\circ}C$

TYPICAL PERFORMANCE CHARACTERISTICS

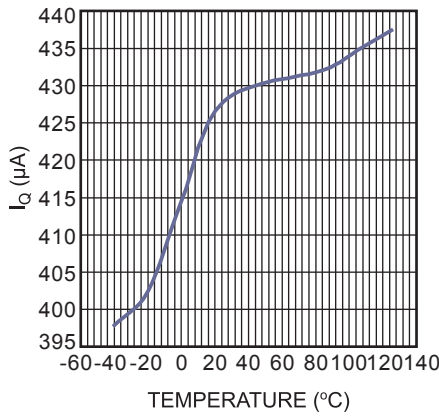
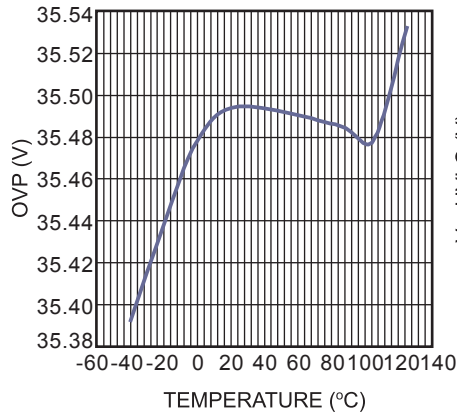
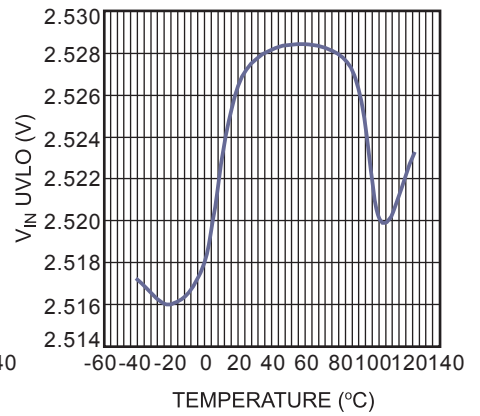
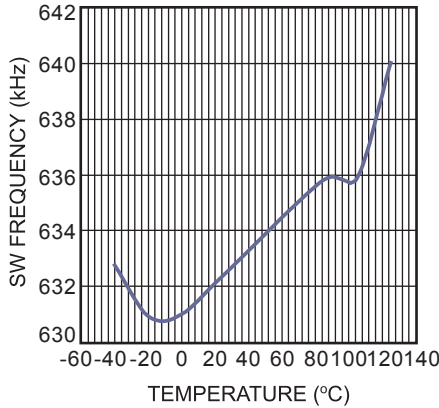
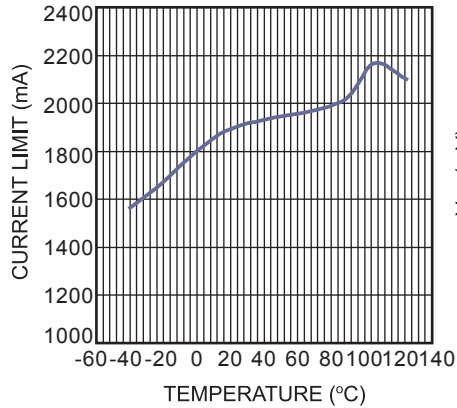
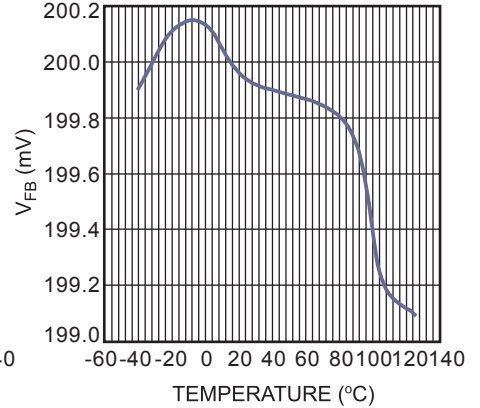
 I_Q vs. Temperature

OVP Voltage vs. Temperature

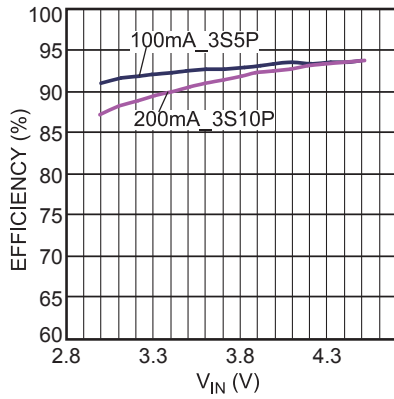
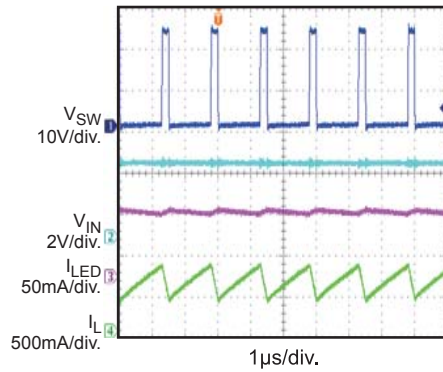
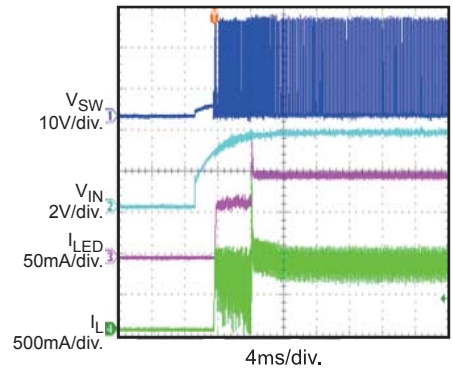
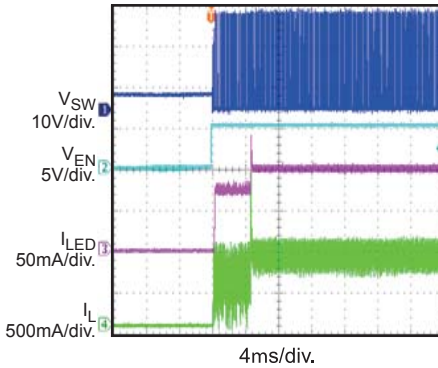
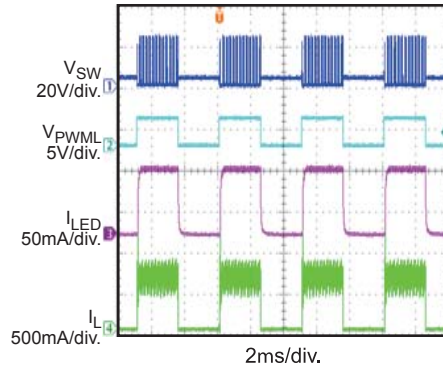
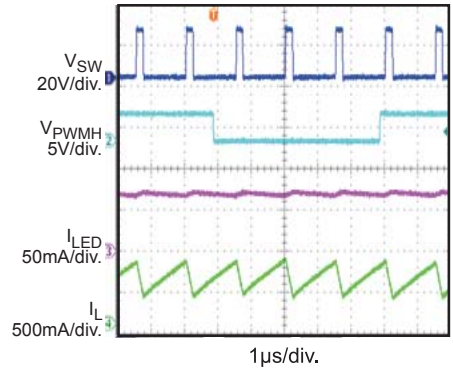
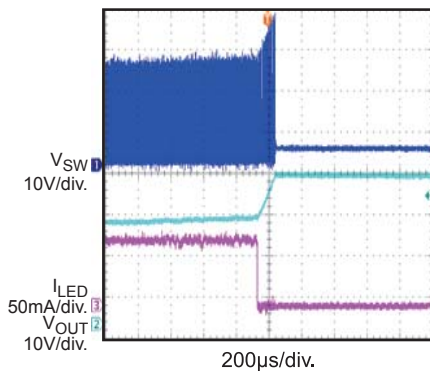
 V_{IN} UVLO Voltage vs. Temperature

SW Frequency Voltage vs. Temperature ($R_{FREQ}=200k\Omega$)

Current Limit vs. Temperature

 V_{FB} Regulation Voltage vs. Temperature

TYPICAL PERFORMANCE CHARACTERISTICS (continued)
 $V_{IN} = 3.6V$, 8 LEDs, $L = 10\mu H(59m\Omega)$ $I_{LED} = 80mA$, $T_A = 25^\circ C$, unless otherwise noted.

Efficiency vs. V_{IN}

Steady State

 V_{IN} Power On
 $I_{LED} = 100mA/String$

EN Power On
 $I_{LED} = 100mA/String$

PWM Dimming
 $f_{DIM} = 200Hz$, $D_{DIM} = 50\%$

Analog Dimming
 $f_{DIM} = 20kHz$, $D_{DIM} = 90\%$

Open LED Protection

PIN FUNCTIONS

Pin #	Name	Description
1	VOUT	Output Voltage. For non-synchronous mode, connect a Schottky diode between SW pin and this pin.
2	SW	Power Switch Node. Drain of the internal low-side MOSFET. Connect the power inductor between SW and VIN pin. For non-synchronous mode, connect a Schottky diode between this pin and VOUT.
3	GND	Ground.
4	FB	LED Current Feedback. Regulates the voltage across the current sense resistor between FB and GND to 200mV.
5	FREQ	Switching Frequency Set. Connect a resistor between this pin and GND to program the converter switching frequency. Do not leave this pin floating.
6	EN/PWML	Enable and PWM Brightness Control Pin. Apply a PWM signal for PWM dimming. For most applications, use a frequency range of 200Hz to 2kHz. A low-level signal longer than 20ms will shutdown the IC.
7	VIN	Input Supply Pin. Provides power for internal power and logic circuits. Must be locally bypassed.
8,9	PWMH	Dimming input pin for PWM input analog dimming, >20kHz PWM signal is recommended. Pull 2 pins high together when analog dimming is not used.
10	BST	Bootstrap. Connect a capacitor between SW and BST pin to provide the synchronous MOSFET gate driver.

FUNCTION BLOCK DIAGRAM

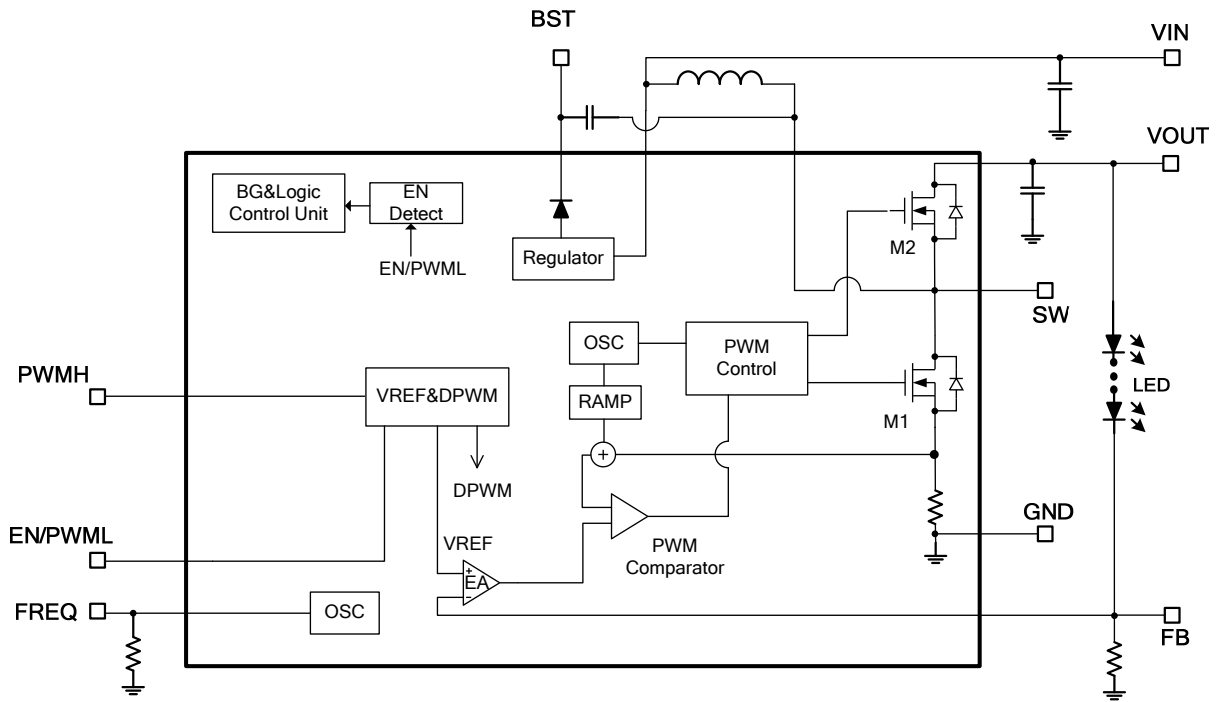

Figure 1: Functional Block Diagram

OPERATION

The MP3309A uses peak-current-mode control to regulate the current through the WLED string. At the start of each oscillator cycle, the control circuit turns on the low-side MOSFET (LS-FET, M1). A stabilizing ramp added to the output of the current-sense amplifier, which then feeds into the positive input of the PWM comparator, prevents sub-harmonic oscillations at duty cycles greater than 50%. When the input of the PWM comparator is equal to the output voltage of the error amplifier, M1 turns off. Then the inductor current flows through the synchronous power MOSFET, which forces the inductor current to decrease.

The voltage at the output of the error amplifier is the amplified difference between the 200mV reference voltage and the feedback voltage. If the feedback voltage starts to drop, the output of the error amplifier increases, increasing the current flowing through the M1, thus increasing the power to the inductor and output power. This method accurately regulates the LED current.

System Startup

When enabled, the MP3309A checks safety limits, including UVLO and over-temperature protection (OTP), over-current protection after passing the OVP test. If all the protection tests pass, the chip then starts boosting the step-up converter with an internal soft-start. During the soft-start, the current limit drops to 0.8A to prevent a large inrush current. This low-current-limit time lasts for 5ms after the IC is enabled.

Synchronous Mode

The converter works in synchronous mode. Synchronous mode can reduce diode power consumption caused by a large voltage drop. This synchronous mode increases the converter efficiency for low LED string voltage. This mode does not need an external Schottky diode, reducing PCB space requirements and BOM costs.

Dimming Control

The MP3309A provides two dimming methods: PWM and analog dimming.

For PWM dimming, apply a PWM signal to the EN/PWML pin. The LED current is then

segmented as per the PWM signal and the average LED current equals:

$$I_{\text{set}} \times D_{\text{dim}}$$

Where D_{dim} is the PWM duty cycle and I_{set} is the LED current amplitude. When PWM signal is high, the converter operates in normal mode. Conversely, when the PWM amplitude is low, the converter stops switching. Make sure that the PWM-signal low-level time is less than 20ms, otherwise the IC will shutdown. Use a 100Hz-to-2kHz PWM-dimming frequency for most dimming ratio requests.

For analog dimming, set the LED current amplitude through an external PWM signal. Implementing analog dimming by connecting the 2 PWMH pins together and apply a PWM signal. An internal RC filter filters the PWM signal. The LED current amplitude equals $I_{\text{set}} \times D_{\text{dim}}$, where D_{dim} is the PWM duty cycle and I_{set} is the LED current amplitude. Use a >20kHz PWM signal to improve filtering performance.

IC Enable and Shutdown

The MP3309A enables the internal band-gap and normal switching when the EN/PWML pin is high. The MP3309A shuts down the chip when the EN/PWML pin is low for longer than 20ms.

Open-String Protection

The MP3309A monitors the VOUT pin for open-string protection. If the LED string is open, the feedback voltage is lower than the reference voltage. The COMP then rises and charges the output capacitor until the VOUT voltage reaches the protection point $V_{\text{OVP}}(35.5\text{V})$.

The IC stops switching when V_{OUT} reaches the OVP threshold, the IC resumes function when V_{OUT} drops below the threshold.

Input Under-Voltage Protection

When V_{IN} exceeds 2.5V, the converter starts to charge the internal reference and provides power to the internal control circuitry. There is UVLO hysteresis, approximately 200mV, as V_{IN} falls. The IC shuts down when the input voltage drops below 2.3V.

Thermal-Shutdown Protection

Thermal shutdown prevents the IC from operating at exceedingly high temperatures. When the die temperature exceeds the upper threshold (T_{ST}), the IC shutdowns and resumes normal operation when the die temperature drops below lower threshold. Typically, the hysteresis is 25°C.

APPLICATION INFORMATION

Selecting the Switching Frequency

The switching frequency of the step-up converter can be programmed from 300kHz to 1.2MHz. A resistor on the FREQ pin sets the internal oscillator frequency for the step-up converter as per the equation below:

$$F_{SW} \text{ (KHz)} = \frac{128000}{R_{FREQ} \text{ (K}\Omega\text{)}}$$

For instance, if $R_{FREQ}=200\text{k}\Omega$, the switching frequency is to 640kHz.

Setting the LED Current

Set the LED current through the current-setting resistor on the FB pin.

$$I_{LED} \text{ (mA)} = \frac{V_{REF} \text{ (V)}}{R_{FB} \text{ (}\Omega\text{)}} \times 1000$$

For instance, if $V_{REF}=200\text{mV}$, and $R_{FB}=10\Omega$, the LED current is 20mA. Do not leave the FB pin floating.

Selecting the Input Capacitor

The input capacitor reduces the surge current drawn from the input supply and the switching noise from the device. The input capacitor impedance at the switching frequency should be less than the input source impedance to prevent the high-frequency switching current from passing through to the input. Use ceramic capacitors with X5R or X7R dielectrics for their low ESR and small temperature coefficients. For most applications, use a 2.2 μF -to-10 μF ceramic capacitor.

Selecting the Inductor

The MP3309A requires an inductor to boost its output voltage. A larger value inductor results in less ripple current, lowering both the peak-inductor current and the stress on the internal N-channel MOSFET. However, the larger inductor is physically larger, has a higher series resistance, and a lower saturation current.

Choose an inductor that does not saturate under the worst-case load conditions. Select the minimum inductor value to ensure that the boost converter works in continuous-conduction mode with high efficiency and good EMI performance.

Calculate the required inductance value using the equation:

$$L \geq \frac{\eta \times V_{OUT} \times D \times (1-D)^2}{2 \times f_{SW} \times I_{LOAD}}$$

$$D = 1 - \frac{V_{IN}}{V_{OUT}}$$

Where V_{IN} and V_{OUT} are the input and output voltages, f_{SW} is the switching frequency, I_{LOAD} is the LED load current, and η is the efficiency.

To avoid hitting the current limit, the worst-case inductor peak current should be less than 80% of the current limit, I_{LIM} .

$$I_{L(PEAK)} = \frac{V_{OUT} \times I_{LOAD}}{\eta V_{IN}} + \frac{V_{IN} \times (V_{OUT} - V_{IN})}{2 \times L \times f_{SW} \times V_{OUT}}$$

Where $I_{L(PEAK)}$ is the inductor peak current.

Selecting the Output Capacitor

The output capacitor keeps the output voltage ripple small and ensures feedback loop stability. The output capacitor impedance must be low at the switching frequency. Ceramic capacitors with X7R dielectrics are recommended for their low ESR characteristics. Selection must also account for the capacitance's dependence on the voltage rating; with a DC bias voltage, the capacitor can lose as much as 50% of its capacitance at its rated voltage rating. Leave a sufficient voltage rating margin when select the component.

For most applications, select a capacitor in the range of 0.33 μF to 3.3 μF .

Setting the Over-Voltage Protection Point

V_{OUT} determines the OVP point for open-string protection. In some cases, an LED string failure results in a 0V feedback voltage. The part then continuously boosts the output voltage higher and higher until the output voltage reaches the programmed OVP threshold to trigger open-string protection.

Dimming Mode

The MP3309A has a smart dimming function for both PWM and analog dimming.

1. For PWM dimming, apply a 100Hz-to-2kHz PWM signal to the EN/PWML pin. Make sure that the PWM-signal low-level time is less than 20ms, otherwise the IC will shutdown.

2. For analog dimming, set the LED current amplitude through an external >20kHz PWM signal on 2 PWMH pins.

Layout Considerations

Careful attention must be paid to the PCB board layout and components placement.

Proper layout of the high frequency switching path is critical to prevent noise and limit electromagnetic interference. The loop consisting of MP3309A's internal low-side MOSFET, synchronous MOSFET or diode, and output capacitor contains a high-frequency ripple current—minimize this loop. Place the output capacitor should as to the IC as possible.

TYPICAL APPLICATION CIRCUITS

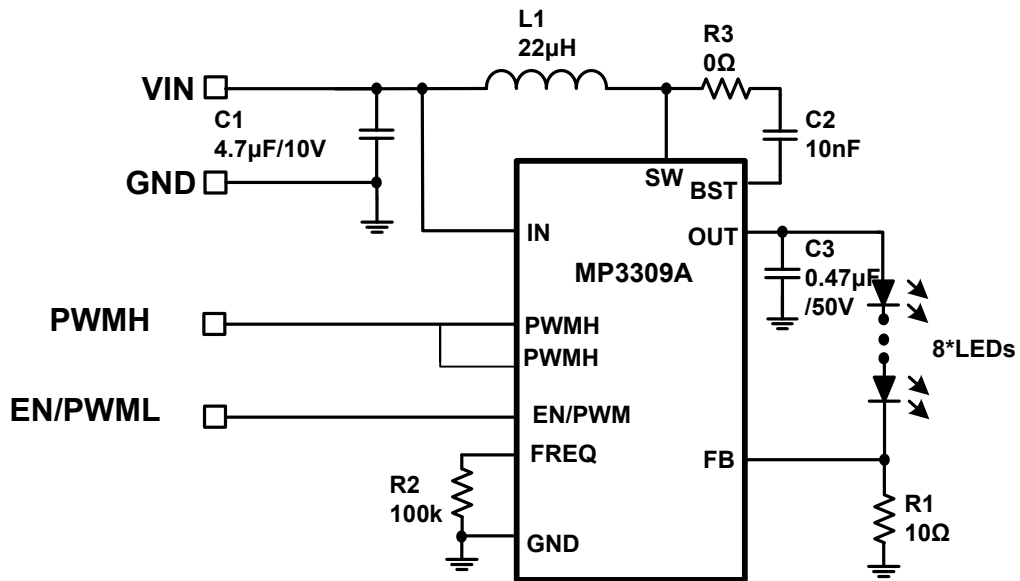
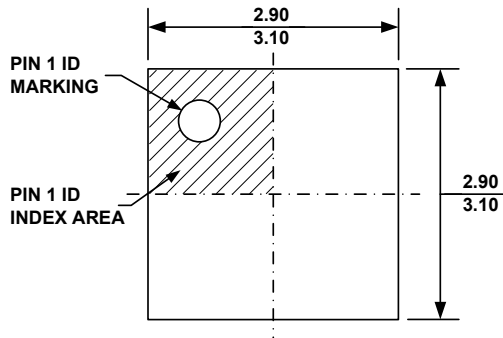

Figure 2: Typical Application for Single String 8LEDs (Synchronous)

PACKAGE INFORMATION

QFN10 (3x3mm)



TOP VIEW

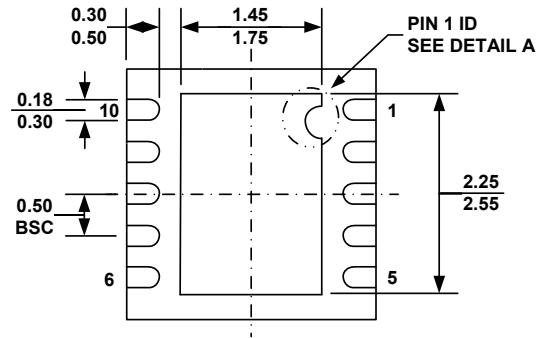

BOTTOM VIEW

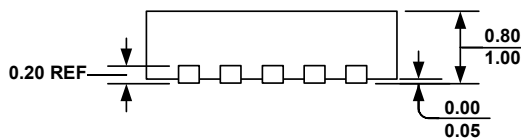

SIDE VIEW

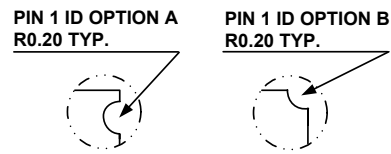

DETAIL A

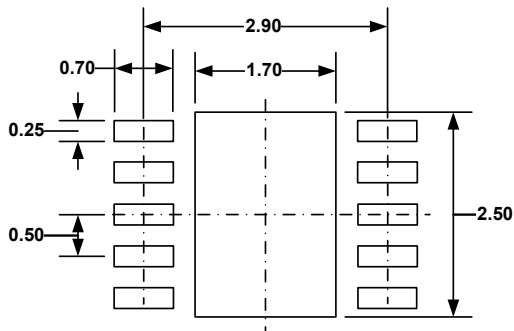

RECOMMENDED LAND PATTERN

NOTE:

- 1) ALL DIMENSIONS ARE IN MILLIMETERS.
- 2) EXPOSED PADDLE SIZE DOES NOT INCLUDE MOLD FLASH.
- 3) LEAD COPLANARITY SHALL BE 0.10 MILLIMETER MAX.
- 4) DRAWING CONFORMS TO JEDEC MO-229, VARIATION VEED-5.
- 5) DRAWING IS NOT TO SCALE.

NOTICE: The information in this document is subject to change without notice. Please contact MPS for current specifications. Users should warrant and guarantee that third party Intellectual Property rights are not infringed upon when integrating MPS products into any application. MPS will not assume any legal responsibility for any said applications.