



Chipsmall Limited consists of a professional team with an average of over 10 year of expertise in the distribution of electronic components. Based in Hongkong, we have already established firm and mutual-benefit business relationships with customers from,Europe,America and south Asia,supplying obsolete and hard-to-find components to meet their specific needs.

With the principle of “Quality Parts,Customers Priority,Honest Operation,and Considerate Service”,our business mainly focus on the distribution of electronic components. Line cards we deal with include Microchip,ALPS,ROHM,Xilinx,Pulse,ON,Everlight and Freescale. Main products comprise IC,Modules,Potentiometer,IC Socket,Relay,Connector.Our parts cover such applications as commercial,industrial, and automotives areas.

We are looking forward to setting up business relationship with you and hope to provide you with the best service and solution. Let us make a better world for our industry!



Contact us

Tel: +86-755-8981 8866 Fax: +86-755-8427 6832

Email & Skype: info@chipsmall.com Web: www.chipsmall.com

Address: A1208, Overseas Decoration Building, #122 Zhenhua RD., Futian, Shenzhen, China



Quad H-Bridge Micromotor Driver with DC/DC Boost Converter

The 17550 is a monolithic quad H-Bridge power IC ideal for portable electronic applications containing tiny bipolar stepper motors and/or brush DC-motors powered by two-to-four cell NiCd/NiMH batteries.

The 17550 operates from 2.5 V to 5.5 V, with independent control of each H-Bridge via parallel 3.0 V or 5.0 V logic-compatible I/O. The device features an on-board DC/DC boost converter that allows motor operation all the way down to 1.6 V (the boost converter supplies the gate-drive voltage for each of the four independent H-bridge output stages). Each output bridge has its own gate-drive and logic circuitry with built-in shoot-through current protection.

The 17550 has four operating modes: Forward, Reverse, Brake, and Tri-States (High Impedance). The 17550 has a low total $R_{DS(ON)}$ of 1.2 Ω max @ 25°C. In addition, it can be set into a very low current-drain standby mode.

The H-Bridge outputs can be independently PWM'ed at up to 200 kHz for speed/torque and current control. The 17550 can efficiently drive many types of micromotors owing to its low output resistance and high output slew rates.

Features

- Low Total $R_{DS(ON)}$ 0.7 Ω (Typ), 1.2 Ω (Max) @ 25°C
- Output Current 700 mA (Continuous per Output)
- Shoot-Through Current Protection Circuit
- PWM Control Input Frequency up to 200 kHz
- Built-In DC/DC Boost Converter
- Low Power Consumption Standby Mode
- Undervoltage Detection and Shutdown Circuit
- Pb-Free Packaging Designated by Suffix Code EV

17550

* **H-BRIDGE MOTOR DRIVER**



ORDERING INFORMATION		
Device	Temperature Range (T_A)	Package
MPC17550EV/EL	-10°C to 60°C	36 VMFP

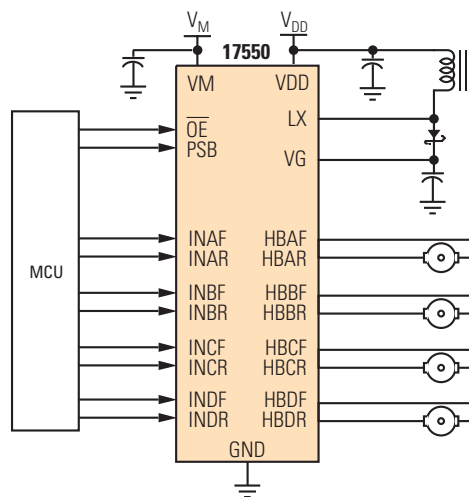

Figure 1. 17550 Simplified Application Diagram

* This document contains certain information on a new product. Specifications and information herein are subject to change without notice.

INTERNAL BLOCK DIAGRAM

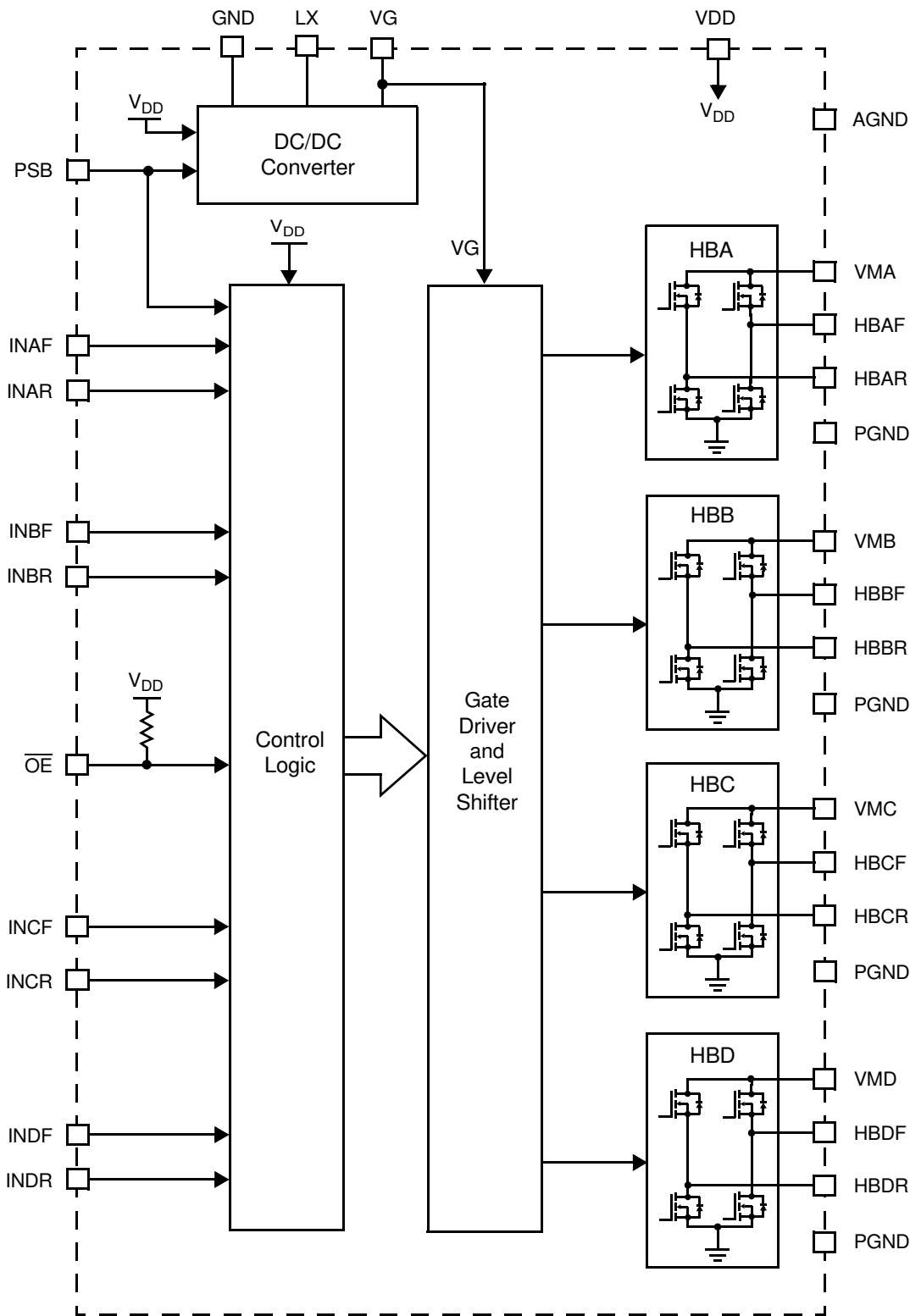

Figure 2. 17550 Simplified Internal Block Diagram

TERMINAL CONNECTIONS

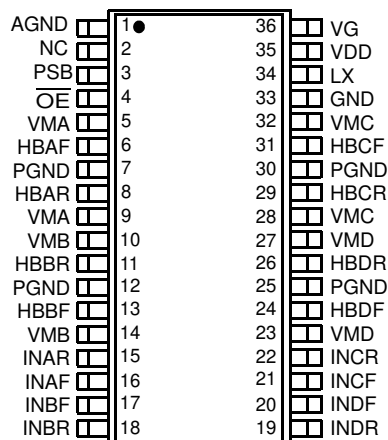

Figure 3. 17550 Terminal Connections

Table 1. Terminal Function Description

Terminal	Terminal Name	Formal Name	Definition
1	AGND	Analog Ground	Analog and logic signal ground reference terminal.
2	NC	No Connect	No connection to this terminal.
3	PSB	Power Standby	Power standby mode control terminal.
4	$\overline{\text{OE}}$	Output Enable	Logic output Enable control of H-Bridges (Low = True).
5, 9	VMA	Motor Drive Power Supply A	Power supply voltage connection for Motor "A" (top of HBA).
6	HBAF	HBA Forward Output	Forward output of H-Bridge A.
8	HBAR	HBA Reverse Output	Reverse output of H-Bridge A.
10, 14	VMB	Motor Drive Power Supply B	Power supply voltage connection for Motor "B" (top of HBB).
11	HBDR	HBB Reverse Output	Reverse output of H-Bridge B.
7, 12, 25, 30	PGND	Power Ground	Power ground connection.
13	HBBF	HBB Forward Output	Forward output of H-Bridge B.
15	INAR	Input Control HBA Reverse	Control signal input for H-Bridge A reverse.
16	INAF	Input Control HBA Forward	Control signal input for H-Bridge A forward.
17	INBF	Input Control HBB Forward	Control signal input for H-Bridge B forward.
18	INBR	Input Control HBB Reverse	Control signal input for H-Bridge B reverse.
19	INDR	Input Control HBD Reverse	Control signal input for H-Bridge D reverse.
20	INDF	Input Control HBD Forward	Control signal input for H-Bridge D forward.
21	INCF	Input Control HBC Forward	Control signal input for H-Bridge C forward.
22	INCR	Input Control HBC Reverse	Control signal input for H-Bridge C reverse.
23, 27	VMD	Motor Drive Power Supply D	Power supply voltage connection for Motor "D" (top of HBD).
24	HBDF	HBD Forward Output	Forward output of H-Bridge D.
26	HBDR	HBD Reverse Output	Reverse output of H-Bridge D.
28, 32	VMC	Motor Drive Power Supply C	Power supply voltage connection for Motor "C" (top of HBC).

Table 1. Terminal Function Description (continued)

Terminal	Terminal Name	Formal Name	Definition
29	HBCR	HBC Reverse Output	Reverse Output of H-Bridge C.
31	HBCF	HCB Forward Output	Forward Output of H-Bridge C.
33	GND	Ground	Control circuit ground terminal for DC/DC circuit ground.
34	LX	DC/DC Converter Switching Transistor Output	Open-drain output of the internal DC/DC converter circuit.
35	VDD	Logic Supply	Control circuit power supply terminal.
36	VG	Gate-Driver Circuit Power Supply	Input terminal for the gate-drive voltage.

ELECTRICAL CONNECTIONS

MAXIMUM RATINGS

Table 2. Maximum Ratings

All voltages are with respect to ground unless otherwise noted. Exceeding the ratings may cause a malfunction or permanent damage to the device.

Rating	Symbol	Value	Unit
Motor Supply Voltage	V_M	-0.5 to 9.0	V
Gate-Driver Circuit Power Supply Voltage	V_G	$V_{DD} - 0.5$ to 14	V
Logic Supply Voltage	V_{DD}	-0.5 to 6.0	V
Signal Input Voltage ⁽¹⁾	V_{IN}	-0.5 to $V_{DD} + 0.5$	V
Driver Output Current			A
Continuous ⁽²⁾	I_O	0.7	
Peak ⁽³⁾	I_{OPK}	2.0	
ESD Voltage ⁽⁴⁾			V
Human Body Model	V_{ESD1}	±2000	
Machine Model	V_{ESD2}	±100	
Storage Temperature Range	T_{STG}	-65 to 150	°C
Operating Ambient Temperature	T_A	-10 to 60	°C
Operating Junction Temperature	T_J	-10 to 150	°C
Thermal Resistance ⁽⁵⁾	$R_{\theta JA}$	TBD	°C/W
Power Dissipation ⁽⁶⁾	P_D	1500	mW
Soldering Temperature ⁽⁷⁾	T_{SOLDER}	260	°C

Notes

- V_{IN} is the voltage level applied to any input terminal.
- I_O is measured as the load current flowing through the H-bridge.
- $T_A = 25^\circ\text{C}$, pulse width < 10 ms at intervals > 0.2 seconds.
- ESD1 testing is performed in accordance with the Human Body Model ($C_{ZAP} = 100$ pF, $R_{ZAP} = 1500$ Ω), ESD2 testing is performed in accordance with the Machine Model ($C_{ZAP} = 200$ pF, $R_{ZAP} = 0$ Ω).
- Mounted on 37 x 50 Cu area (1.6 mm FR-4 PCB).
- Maximum at $T_A = 25^\circ\text{C}$.
- Soldering temperature limit is for 10 seconds maximum duration. Not designed for immersion soldering. Exceeding these limits may cause malfunction or permanent damage to the device.

STATIC ELECTRICAL CHARACTERISTICS

Table 3. STATIC ELECTRICAL CHARACTERISTICS

Characteristics noted under conditions $T_A = 25^\circ\text{C}$, $V_{DD} = 3.0\text{ V}$, $V_M = 2.5\text{ V}$, $\text{GND} = 0\text{ V}$, $f_{IN} = 176\text{ kHz}$ unless otherwise noted. Typical values noted reflect the approximate parameter means at $T_A = 25^\circ\text{C}$ under nominal conditions unless otherwise noted.

Characteristic	Symbol	Min	Typ	Max	Unit
POWER					
Motor Supply Voltage	V_M	1.6	2.5	5.5	V
Logic Supply Voltage	V_{DD}	2.5	3.0	5.5	V
Standby Power Supply Current ⁽⁸⁾					μA
Motor Supply Standby Current	I_{VMSTBY}	–	–	1.0	
Logic Supply Standby Current	$I_{VDDSTBY}$	–	–	1.0	
Logic Supply Current	I_{VDD}	–	0.3	1.0	mA
Gate Driver Circuit Power Supply Current ⁽⁹⁾					
Standby (PSB = "L")	I_{DDCO}	–	–	1.0	μA
No Signal Operating	I_{DDCN}	–	1.0	3.0	μA
Input Signal Operating ⁽¹⁰⁾	I_{DDC}	–	19	25	mA
Driver Output ON Resistance ⁽¹¹⁾	$R_{DS(ON)}$	–	0.7	1.2	Ω
GATE DRIVE					
Gate Driver Circuit Power Supply Voltage ⁽¹²⁾	V_G	10	11.5	13	V
CONTROL LOGIC					
Logic Input Voltage ⁽¹³⁾	V_{IN}	0	–	V_{DD}	V
Logic Input (F, R, PSB, \overline{OE})					
High-Level Input Voltage	V_{IH}	$V_{DD} \times 0.7$	–	–	V
Low-Level Input Voltage	V_{IL}	–	–	$V_{DD} \times 0.3$	V
High-Level Input Current	I_{IH}	–	–	1.0	μA
Low-Level Input Current	I_{IL}	-1.0	–	–	μA

Notes

8. Applies individually to each H-Bridge.
9. Average inductor current for DC/DC converter (connected between V_{DD} and LX [L = 1.0 mH, C = 2.2 μF]).
10. Full drive (input signal to all input control terminals).
11. The total H-bridge ON resistance when V_G is 11.5 V.
12. When voltage is supplied externally without built-in DC/DC.
13. V_{IN} is the voltage level applied to any input.

DYNAMIC ELECTRICAL CHARACTERISTICS

Table 4. DYNAMIC ELECTRICAL CHARACTERISTICS

Characteristics noted under conditions $T_A = 25^\circ\text{C}$, $V_{DD} = 3.0\text{ V}$, $V_M = 2.5\text{ V}$, $\text{GND} = 0\text{ V}$, $f_{IN} = 176\text{ kHz}$ unless otherwise noted. Typical values noted reflect the approximate parameter means at $T_A = 25^\circ\text{C}$ under nominal conditions unless otherwise noted.

Characteristic	Symbol	Min	Typ	Max	Unit
INPUT					
Pulse Input Frequency ⁽¹⁴⁾	f_{IN}	–	–	200	kHz
Internal Oscillator Frequency	f_{OSC}	–	100	200	kHz
OUTPUT					
Gate Driver Circuit Power Supply Wake-Up Time	t_{VGON}	–	10	20	ms
Propagation Delay Time					μs
Turn-ON Time	t_{PLH}	–	0.2	1.0	
Turn-OFF Time	t_{PHL}	–	0.2	1.0	

Notes

14. f_{IN} is the signal frequency applied to an input terminal (F, R).

FUNCTIONAL DESCRIPTION

INTRODUCTION

The 17550 is a monolithic quad H-Bridge ideal for portable electronic applications containing multiple bipolar stepper motors and/or brush DC motors. The device features an on-board DC/DC converter to provide gate-drive voltages, as well as level-shifting circuitry. The control logic translates the input signals to the gate-driver circuitry while providing cross-conduction suppression.

The 17550 has four operating modes: Forward, Reverse, Brake, and Tri-Styled (High Impedance). The MOSFETs comprising the output bridge have a total source+sink $R_{DS(ON)} \leq 1.2 \Omega$.

The 17550 can simultaneously drive four brush DC motors or two bipolar stepper motors. The drivers are designed to be PWM'ed at frequencies up to 200 kHz.

FUNCTIONAL TERMINAL DESCRIPTION

LOGIC SUPPLY (VDD)

The VDD terminal carries the logic supply voltage and current into the logic sections of the IC. V_{DD} has an undervoltage threshold. If the supply voltage drops below the undervoltage threshold, the output power stage switches to a tri-state condition. When the supply voltage returns to a level that is above the threshold, the power stage automatically resumes normal operation according to the established condition of the input control terminals.

CONTROL SIGNAL INPUT FOR H-BRIDGE, F=FORWARD, R= REVERSE (INAF, INAR, INBF, INBR, INCF, INCR, INDF, INDR)

These logic input control terminals control each H-Bridge output; e.g., IN^*F logic HIGH = HB^*F HIGH; likewise, IN^*R logic HIGH = HB^*R HIGH. However, if both "F" and "R" inputs are taken HIGH, the associated bridge's outputs are both tri-stated (refer to [Table 5, Truth Table](#), page 8).

OUTPUT ENABLE (\overline{OE})

\overline{OE} terminal is a LOW = TRUE enable input. When \overline{OE} = HIGH, all H-Bridge outputs are tri-stated (high impedance) regardless of logic inputs states.

OUTPUT OF H-BRIDGE, R=REVERSE, F=FORWARD (HBAF, HBAR, HBBF, HBBR, HBCF, HBCR, HBDF, HBDR)

These terminals provide connection to the outputs of each of the internal H-Bridges (see [Figure 2, 17550 Simplified Internal Block Diagram](#), page 2).

POWER SUPPLY VOLTAGE CONNECTION FOR MOTORS A, B, C, D (VMA, VMB, VMC, VMD)

The VM terminals carry the main supply voltage and current into the power sections of the 17550. This supply then becomes controlled and/or modulated by the 17550 as it delivers the power to the loads attached between the H-Bridge output terminals. All VM terminals must be connected together on the printed circuit board.

DC/ DC CONVERTER SWITCHING TRANSISTOR OUTPUT (LX)

The LX terminal is the open-drain output of the internal DC/DC converter circuit. It is the junction for the external inductor and the anode of the external Schottky diode.

GATE-DRIVER CIRCUIT POWER SUPPLY (VG)

The VG terminal is the input terminal for the gate-drive voltage. It can be supplied from the built-in DC/DC converter or from an external source.

GROUND TERMINALS (GND, AGND, PGND)

All ground terminals must be tied together on the PCB.

POWER STANDBY MODE CONTROL (PSB)

The PSB input controls the functioning of power output stages (the H-Bridges). When this input signal turns Low, the output stages and Internal DC/DC Converter which makes Gate Voltage are disabled and all the outputs are opened (High Impedance). When this input signal turns High, the output stages and Internal DC/DC Converter are enabled and the H-Bridges operate normally.

TYPICAL APPLICATIONS

INTRODUCTION

The 17550's built-in DC/DC converter must be connected to an external inductor, rectifier, and filter capacitor. This step-up converter generates the gate-drive voltage, V_G , required by the internal gate driver circuits. Although there is some latitude in selecting the values for the external component, care must be taken that V_G does not exceed 14 V. Additionally, too low an inductance will cause large instantaneous switching currents, which may damage the device.

Important Do not use an inductance lower than 330 μH .

To attain high-efficiency operation, the rectifier should be a Schottky diode, and the filter capacitor should be of the low

Equivalent Series Resistance (ESR) type. Attention should be paid to proper switch mode power supply PCB layout practice. Some experimentation may be required to determine optimal external component values. The recommended starting values are $L = 1.0 \text{ mH}$, $C = 2.2 \mu\text{F}$.

The DC/DC converter includes its own internal oscillator and does not require an external clock input.

TYPICAL APPLICATION

Two typical application schematics are shown in [Figure 6](#) and [Figure 7](#).

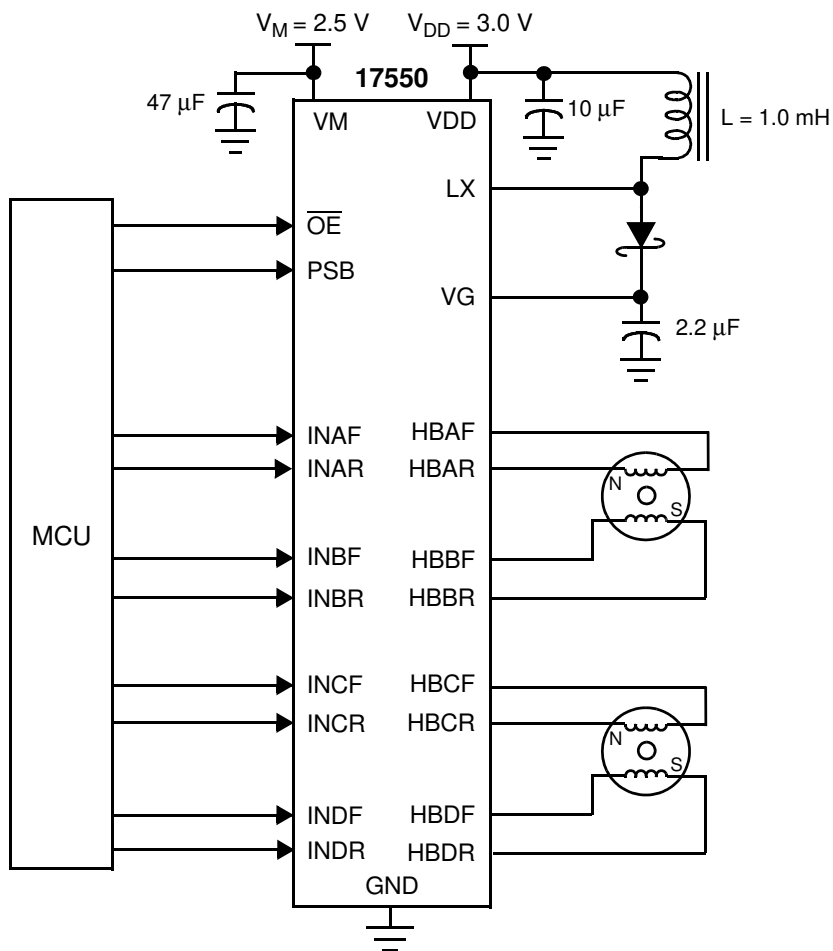

Figure 6. Typical 17550 Application - Controlling Stepper Motors

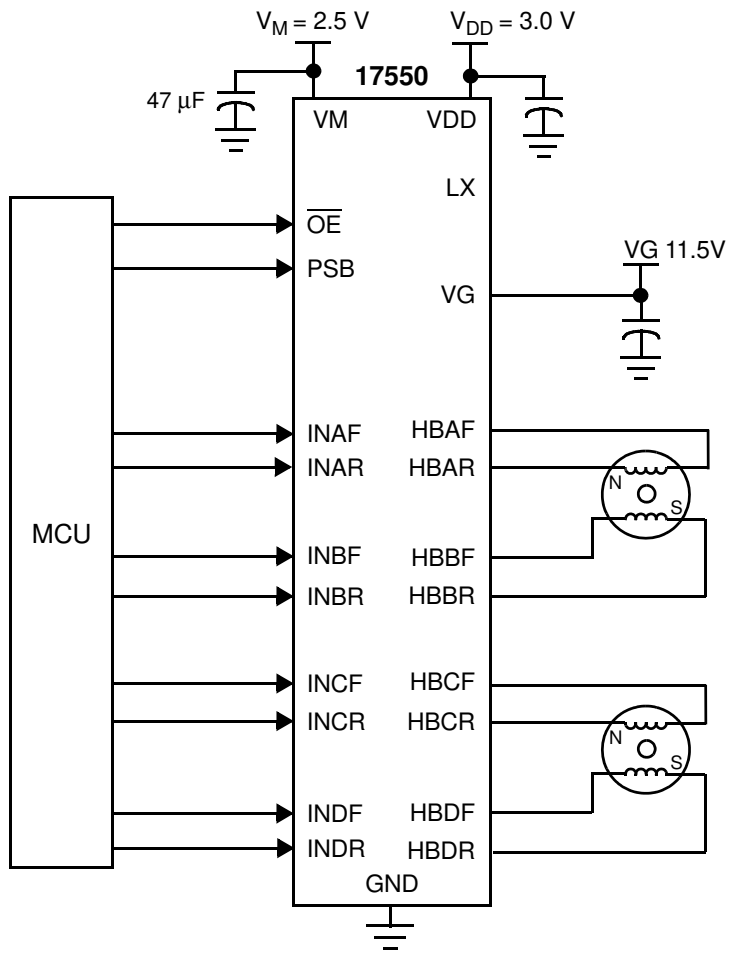

Figure 7. Typical 17550 Application - No Internal DC-DC Used

CEMF SNUBBING TECHNIQUES

Care must be taken to protect the IC from potentially damaging CEMF spikes induced when commuting currents in inductive loads. Typical practice is to provide snubbing of voltage transients by placing a capacitor or zener at the motor supply voltage terminal (VM) (see [Figure 8](#)).

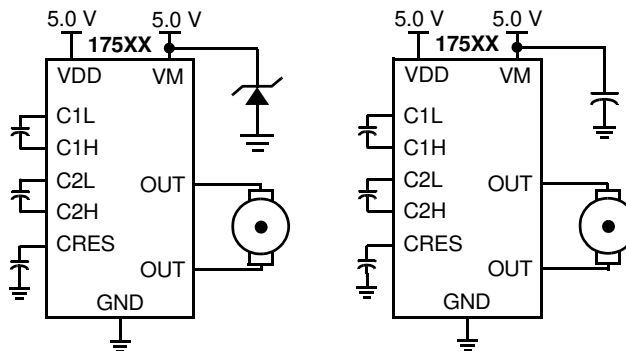
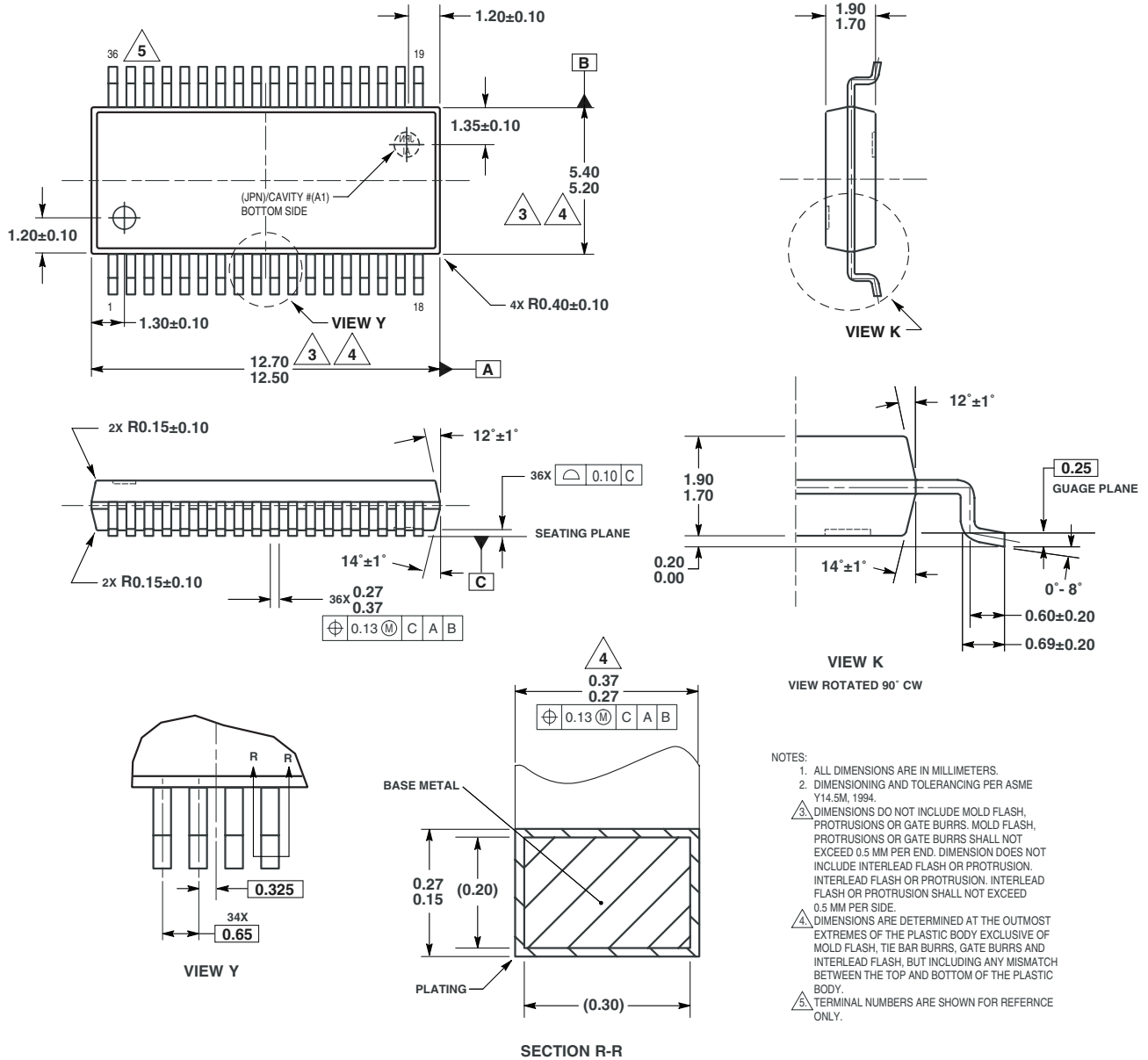

Figure 8. CEMF Snubbing Techniques

PACKAGING

PACKAGE DIMENSIONS

Important: For the most current revision of the package, visit www.freescale.com and perform a keyword search on the 98A number listed below.



EV (Pb-FREE) SUFFIX
36-LEAD VMFP
PLASTIC PACKAGE
CASE 1522-01
ISSUE O

REVISION HISTORY

REVISION	DATE	DESCRIPTION OF CHANGES
2.0	7/2006	<ul style="list-style-type: none"> • Converted to Freescale format and updated to the prevailing form and style • Added typical Application for non DC/DC use • Added RoHS compliance

How to Reach Us:

Home Page:

www.freescale.com

E-mail:

support@freescale.com

USA/Europe or Locations Not Listed:

Freescale Semiconductor
Technical Information Center, CH370
1300 N. Alma School Road
Chandler, Arizona 85224
+1-800-521-6274 or +1-480-768-2130
support@freescale.com

Europe, Middle East, and Africa:

Freescale Halbleiter Deutschland GmbH
Technical Information Center
Schatzbogen 7
81829 Muenchen, Germany
+44 1296 380 456 (English)
+46 8 52200080 (English)
+49 89 92103 559 (German)
+33 1 69 35 48 48 (French)
support@freescale.com

Japan:

Freescale Semiconductor Japan Ltd.
Headquarters
ARCO Tower 15F
1-8-1, Shimo-Meguro, Meguro-ku,
Tokyo 153-0064
Japan
0120 191014 or +81 3 5437 9125
support.japan@freescale.com

Asia/Pacific:

Freescale Semiconductor Hong Kong Ltd.
Technical Information Center
2 Dai King Street
Tai Po Industrial Estate
Tai Po, N.T., Hong Kong
+800 2666 8080
support.asia@freescale.com

For Literature Requests Only:

Freescale Semiconductor Literature Distribution Center
P.O. Box 5405
Denver, Colorado 80217
1-800-441-2447 or 303-675-2140
Fax: 303-675-2150
LDCForFreescaleSemiconductor@hibbertgroup.com

Information in this document is provided solely to enable system and software implementers to use Freescale Semiconductor products. There are no express or implied copyright licenses granted hereunder to design or fabricate any integrated circuits or integrated circuits based on the information in this document.

Freescale Semiconductor reserves the right to make changes without further notice to any products herein. Freescale Semiconductor makes no warranty, representation or guarantee regarding the suitability of its products for any particular purpose, nor does Freescale Semiconductor assume any liability arising out of the application or use of any product or circuit, and specifically disclaims any and all liability, including without limitation consequential or incidental damages. "Typical" parameters that may be provided in Freescale Semiconductor data sheets and/or specifications can and do vary in different applications and actual performance may vary over time. All operating parameters, including "Typicals", must be validated for each customer application by customer's technical experts. Freescale Semiconductor does not convey any license under its patent rights nor the rights of others. Freescale Semiconductor products are not designed, intended, or authorized for use as components in systems intended for surgical implant into the body, or other applications intended to support or sustain life, or for any other application in which the failure of the Freescale Semiconductor product could create a situation where personal injury or death may occur. Should Buyer purchase or use Freescale Semiconductor products for any such unintended or unauthorized application, Buyer shall indemnify and hold Freescale Semiconductor and its officers, employees, subsidiaries, affiliates, and distributors harmless against all claims, costs, damages, and expenses, and reasonable attorney fees arising out of, directly or indirectly, any claim of personal injury or death associated with such unintended or unauthorized use, even if such claim alleges that Freescale Semiconductor was negligent regarding the design or manufacture of the part.

Freescale™ and the Freescale logo are trademarks of Freescale Semiconductor, Inc. All other product or service names are the property of their respective owners.

© Freescale Semiconductor, Inc., 2006. All rights reserved.