



Chipsmall Limited consists of a professional team with an average of over 10 year of expertise in the distribution of electronic components. Based in Hongkong, we have already established firm and mutual-benefit business relationships with customers from,Europe,America and south Asia,supplying obsolete and hard-to-find components to meet their specific needs.

With the principle of “Quality Parts,Customers Priority,Honest Operation,and Considerate Service”,our business mainly focus on the distribution of electronic components. Line cards we deal with include Microchip,ALPS,ROHM,Xilinx,Pulse,ON,Everlight and Freescale. Main products comprise IC,Modules,Potentiometer,IC Socket,Relay,Connector.Our parts cover such applications as commercial,industrial, and automotives areas.

We are looking forward to setting up business relationship with you and hope to provide you with the best service and solution. Let us make a better world for our industry!



Contact us

Tel: +86-755-8981 8866 Fax: +86-755-8427 6832

Email & Skype: info@chipsmall.com Web: www.chipsmall.com

Address: A1208, Overseas Decoration Building, #122 Zhenhua RD., Futian, Shenzhen, China



Low Voltage 2.5 V and 3.3 V CMOS PLL Clock Driver

The MPC9600 is a low voltage 2.5 V or 3.3 V compatible, 1:21 PLL based clock driver and fanout buffer. With output frequencies up to 200 MHz and output skews of 150 ps, the device meets the needs of the most demanding clock tree applications.

Features:

- Multiplication of input frequency by 2, 3, 4 and 6
- Distribution of output frequency to 21 outputs organized in three output banks: QA0-QA6, QB0-QB6, QC0-QC6, each fully selectable
- Fully integrated PLL
- Selectable output frequency range is 50 to 100 MHz and 100 to 200 MHz
- Selectable input frequency range is 16.67 to 33 MHz and 25 to 50 MHz
- LVCMOS outputs
- Outputs disable to high impedance (except QFB)
- LVCMOS or LVPECL reference clock options
- 48 lead QFP packaging
- ± 50 ps cycle-to-cycle jitter
- 150 ps maximum output-to-output skew
- 200 ps maximum static phase offset window

The MPC9600 is a fully LVCMOS 2.5 V or 3.3 V compatible PLL clock driver. The MPC9600 has the capability to generate clock signals of 50 to 200 MHz from clock sources of 16.67 to 50 MHz. The internal PLL is optimized for this frequency range and does not require external loop filter components. QFB provides an output for the external feedback path to the feedback input FB_IN. The QFB divider ratio is configurable and determines the PLL frequency multiplication factor when QFB is directly connected to FB_IN. The MPC9600 is optimized for minimizing the propagation delay between the clock input and FB_IN.

Three output banks of 7 outputs each bank can be individually configured to divide the VCO frequency by 2 or by 4. Combining the feedback and output divider ratios, the MPC9600 is capable to multiply the input frequency by 2, 3, 4 and 6.

The reference clock is selectable either LVPECL or LVCMOS. The LVPECL reference clock feature allows the designer to use LVPECL fanout buffers for the inner branches of the clock distribution tree. All control inputs accept LVCMOS compatible levels. The outputs provide low impedance LVCMOS outputs capable of driving parallel terminated 50 Ω transmission to $V_{TT}=V_{CC}/2$. For series terminated lines the MPC9600 can drive two lines per output giving the device an effective total fanout of 1:42. With guaranteed maximum output-to-output skew of 150 ps, the MPC9600 PLL clock driver meets the synchronization requirements of the most demanding systems.

The VCCA analog power pin doubles as a PLL bypass select line for test purpose. When the VCCA is driven to GND the reference clock will bypass the PLL.

The device is packaged in a 48-lead LQFP package to provide optimum combination of board density and performance.

MPC9600

3.3 V OR 2.5 V LOW VOLTAGE CMOS PLL CLOCK DRIVER



FA SUFFIX
48-LEAD LQFP PACKAGE
CASE 932-03

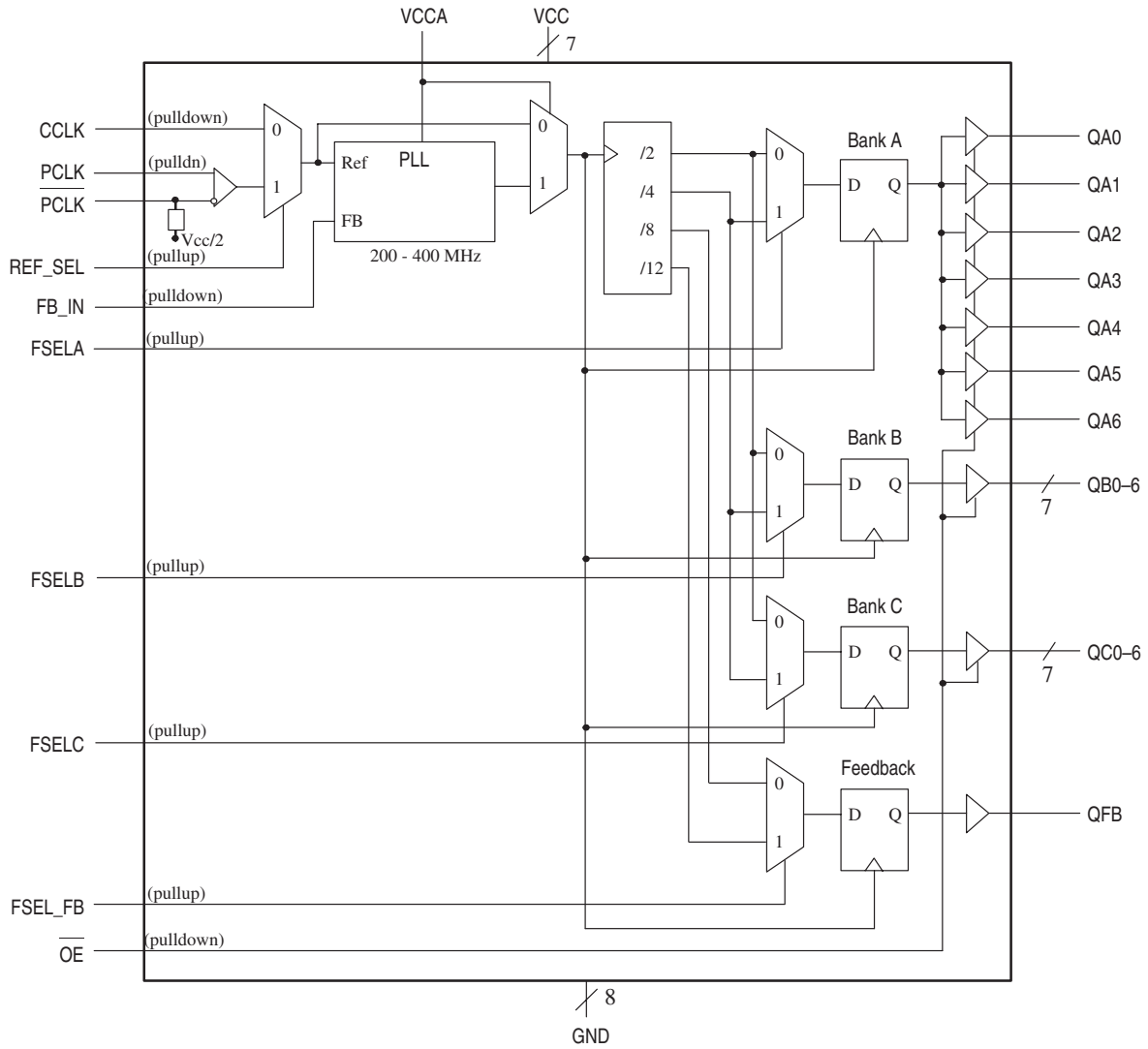

Figure 1. MPC9600 Logic Diagram

Freescale Semiconductor, Inc.

PIN CONFIGURATION

Pin	I/O	Type	Description
PCLK, $\overline{\text{PCLK}}$	Input	PECL	Differential reference clock frequency input
CCLK	Input	LVC MOS	Reference clock input
FB_IN	Input	LVC MOS	PLL feedback clock input
QAn	Output	LVC MOS	Bank A outputs
QBn	Output	LVC MOS	Bank B outputs
QCn	Output	LVC MOS	Bank C outputs
QFB	Output	LVC MOS	Differential feedback output
REF_SEL	Input	LVC MOS	Reference clock input select
FSELA	Input	LVC MOS	Selection of bank A output frequency
FSELB	Input	LVC MOS	Selection of bank B output frequency
FSELC	Input	LVC MOS	Selection of bank C output frequency
FSEL_FB	Input	LVC MOS	Selection of feedback frequency
$\overline{\text{OE}}$	Input	LVC MOS	Output enable
VCCA		Power supply	Analog power supply and PLL bypass. An external VCC filter is recommended for VCCA
VCC		Power supply	Core power supply
GND		Ground	Ground

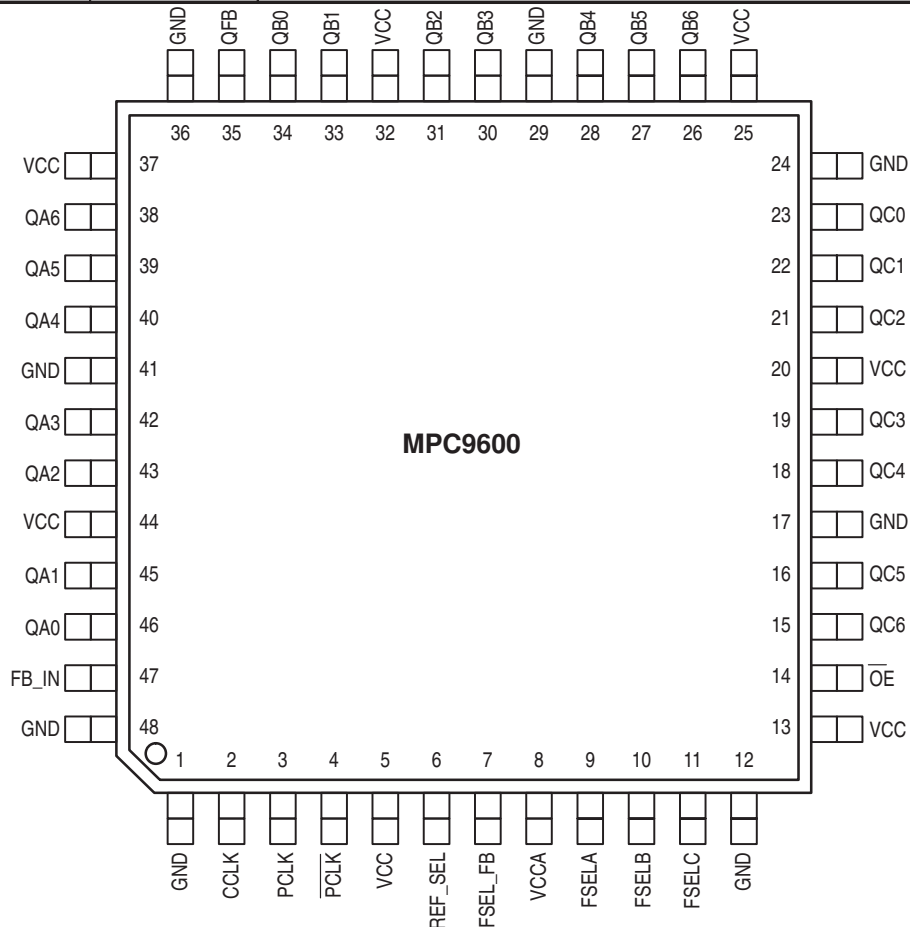

Figure 2. 48 Lead Package Pinout (Top View)

FUNCTION TABLE (CONTROLS)

Control Pin	0	1
REF_SEL	CCLK	PCLK
VCCA	PLL Bypass ¹	PLL Power
OE	Outputs Enabled	Outputs Disabled (except QFB)
FSELA	Output Bank A at VCO/2	Output Bank A at VCO/4
FSELB	Output Bank B at VCO/2	Output Bank B at VCO/4
FSELC	Output Bank C at VCO/2	Output Bank C at VCO/4
FSEL_FB	Feedback Output at VCO/8	Feedback Output at VCO/12

1..VCCA = GND, PLL off and bypassed for static test and diagnosis

Table 1: ABSOLUTE MAXIMUM RATINGS*

Symbol	Parameter	Min	Max	Unit
V _{CC}	Supply Voltage	-0.3	4.6	V
V _{IN}	DC Input Voltage	-0.3	V _{CC} + 0.3	V
V _{OUT}	DC Output Voltage	-0.3	V _{CC} + 0.3	V
I _{IN}	DC Input Current		±20	mA
I _{OUT}	DC Output Current		±50	mA
T _{Stor}	Storage Temperature Range	-40	125	°C

* Absolute maximum continuous ratings are those values beyond which damage to the device may occur. Exposure to these conditions or conditions beyond those indicated may adversely affect device reliability. Functional operation under absolute-maximum-rated conditions is not implied.

Table 2: GENERAL SPECIFICATIONS

Symbol	Characteristics	Min	Typ	Max	Unit	Condition
V _{TT}	Output Termination Voltage		V _{CC} ÷ 2		V	
MM	ESD Protection (Machine Model)	400			V	
HBM	ESD Protection (Human Body Model)	4000			V	
CDM	ESD Protection (Charged Device Model)	1500			V	
LU	Latch-Up Immunity	200			mA	
C _{PD}	Power Dissipation Capacitance		10		pF	Per output
C _{IN}	Input Capacitance		4.0		pF	Inputs

Table 3: DC CHARACTERISTICS (V_{CC} = 3.3 V ±5%, T_A = -40° to +85°C)

Symbol	Characteristics	Min	Typ	Max	Unit	Condition
V _{IH}	Input High Voltage	2.0		V _{CC} + 0.3	V	LVC MOS
V _{IL}	Input Low Voltage			0.8	V	LVC MOS
V _{PP}	Peak-to-peak Input Voltage (DC) PCLK, PCLK	250			mV	LVPECL
V _{CMR} ^a	Common Mode Range (DC) PCLK, PCLK	1.0		V _{CC} -0.6	V	LVPECL
V _{OH}	Output High Voltage	2.4			V	I _{OH} = -24 mA ^b
V _{OL}	Output Low Voltage			0.55 0.30	V V	I _{OL} = 24mA I _{OL} = 12mA
Z _{OUT}	Output Impedance		14 – 17		Ω	
I _{IN}	Input Leakage Current			±150	μA	V _{IN} = V _{CC} or GND
I _{CCA}	Maximum PLL Supply Current		2.0	5.0	mA	V _{CCA} Pin
I _{CCQ}	Maximum Quiescent Supply Current			1.0	mA	All V _{CC} Pins

- a. V_{CMR} (DC) is the crosspoint of the differential input signal. Functional operation is obtained when the crosspoint is within the V_{CMR} range and the input swing lies within the V_{PP} (DC) specification.
- b. The MPC9600 is capable of driving 50Ω transmission lines on the incident edge. Each output drives one 50Ω parallel terminated transmission line to a termination voltage of V_{TT}. Alternatively, the device drives up to two 50Ω series terminated transmission lines.

Table 4: DC CHARACTERISTICS ($V_{CC} = 2.5\text{ V} \pm 5\%$, $T_A = -40^\circ$ to $+85^\circ\text{C}$)

Symbol	Characteristics	Min	Typ	Max	Unit	Condition
V_{IH}	Input High Voltage	1.7		$V_{CC} + 0.3$	V	LVC MOS
V_{IL}	Input Low Voltage			0.7	V	LVC MOS
V_{PP}	Peak-to-peak input voltage (DC) PCLK, PCLK	250			mV	LVPECL
V_{CMR}^a	Common Mode Range (DC) PCLK, PCLK	1.0		$V_{CC}-0.6$	V	LVPECL
V_{OH}	Output High Voltage	1.8			V	$I_{OH} = -15\text{ mA}^b$
V_{OL}	Output Low Voltage			0.6	V	$I_{OL} = 15\text{ mA}$
Z_{OUT}	Output Impedance		17 – 20		Ω	
I_{IN}	Input Leakage Current			± 150	μA	$V_{IN} = V_{CC}$ or GND
I_{CCA}	Maximum PLL Supply Current		3.0	5.0	mA	V_{CCA} Pin
I_{CCQ}	Maximum Quiescent Supply Current			1.0	mA	All V_{CC} Pins

- a. V_{CMR} (DC) is the crosspoint of the differential input signal. Functional operation is obtained when the crosspoint is within the V_{CMR} range and the input swing lies within the V_{PP} (DC) specification.
- b. The MPC9600 is capable of driving 50 Ω transmission lines on the incident edge. Each output drives one 50 Ω parallel terminated transmission line to a termination voltage of V_{TT} . Alternatively, the device drives up to two 50 Ω series terminated transmission lines per output.

Table 5: AC CHARACTERISTICS ($V_{CC} = 3.3\text{ V} \pm 5\%$ or $V_{CC} = 2.5\text{ V} \pm 5\%$, $T_A = -40^\circ$ to $+85^\circ\text{C}$)^a

Symbol	Characteristics	Min	Typ	Max	Unit	Condition	
f_{ref}	Input Frequency						
	÷ 8 feedback (FSEL_FB=0)	25		50	MHz	PLL locked	
	÷ 12 feedback (FSEL_FB=1)	16.67		33	MHz	PLL locked	
	Static test mode ($V_{CCA} = \text{GND}$)	0		500	MHz	$V_{CCA} = \text{GND}$	
f_{VCO}	VCO Frequency	200		400	MHz		
f_{MAX}	Maximum Output Frequency	÷ 2 outputs (FSELx=0)	100	200	MHz	PLL locked	
		÷ 4 outputs (FSELx=1)	50	100	MHz	PLL locked	
f_{refDC}	Reference Input Duty Cycle	25		75	%		
V_{PP}	Peak-to-peak Input Voltage PCLK, PCLK	500		1000	mV	LVPECL	
V_{CMR}^b	Common Mode Range PCLK, PCLK	($V_{CC} = 3.3\text{ V} \pm 5\%$)	1.2	$V_{CC}-0.8$	V	LVPECL	
		($V_{CC} = 2.5\text{ V} \pm 5\%$)	1.2	$V_{CC}-0.6$	V	LVPECL	
t_r, t_f	CCLK Input Rise/Fall Time			1.0	ns	see Figure 12	
$t(\varnothing)$	Propagation Delay (static phase offset) CCLK to FB_IN		-60	+40	ps	PLL locked	
		PECL_CLK to FB_IN	+30	+130	ps	PLL locked	
$t_{sk(o)}$	Output-to-output Skew	all outputs, single frequency		70	150	ps	Measured at coincident rising edge
		all outputs, multiple frequency		70	150	ps	
		within QAx output bank		30	75	ps	
		within QBx outputs		40	125	ps	
	within QCx outputs		30	75	ps		
DC	Output Duty Cycle	45	50	55	%		
t_r, t_f	Output Rise/Fall Time	0.1		1.0	ns	see Figure 12	
$t_{PLZ, HZ}$	Output Disable Time			10	ns		
$t_{PZL, ZH}$	Output Enable Time			10	ns		
BW	PLL Closed Loop Bandwidth	÷ 8 feedback (FSEL_FB=0)		1.0 – 10	MHz	-3 dB point of PLL transfer characteristic	
		÷ 12 feedback (FSEL_FB=1)		0.6 – 4.0	MHz		

Freescale Semiconductor, Inc.

Table 5: AC CHARACTERISTICS ($V_{CC} = 3.3\text{ V} \pm 5\%$ or $V_{CC} = 2.5\text{ V} \pm 5\%$, $T_A = -40^\circ$ to $+85^\circ\text{C}$)^a

Symbol	Characteristics	Min	Typ	Max	Unit	Condition
$t_{\text{JIT(CC)}}$	Cycle-to-cycle Jitter ^c All outputs in $\div 2$ configuration All outputs in $\div 4$ configuration		40 40	130 180	ps ps	See application section for other configurations
$t_{\text{JIT(PER)}}$	Period Jitter ^c All outputs in $\div 2$ configuration All outputs in $\div 4$ configuration		25 20	70 100	ps ps	See application section for other configurations
$t_{\text{JIT}(\varnothing)}$	I/O Phase Jitter (1σ) $V_{CC} = 3.3\text{V}$ $V_{CC} = 2.5\text{V}$			17 ^d 15 ^c	ps ps	RMS value at $f_{\text{VCO}}=400\text{MHz}$
t_{LOCK}	Maximum PLL Lock Time			5.0	ms	

- a. AC characteristics are applicable over the entire ambient temperature and supply voltage range and are production tested. AC characteristics apply for parallel output termination of $50\ \Omega$ to V_{TT} .
- b. V_{CMR} (AC) is the crosspoint of the differential input signal. Normal AC operation is obtained when the crosspoint is within the V_{CMR} range and the input swing lies within the V_{PP} (AC) specification. Violation of V_{CMR} or V_{PP} impacts static phase offset $t_{\text{JIT}(\varnothing)}$.
- c. Cycle-to-cycle and period jitter depends on output divider configuration.
- d. See applications section for max I/O phase jitter versus frequency.

APPLICATIONS INFORMATION

Programming the MPC9600

The MPC9600 clock driver outputs can be configured into several divider modes. Additionally the external feedback of the device allows for flexibility in establishing various input to output frequency relationships. The selectable feedback divider of the three output groups allows the user to configure the device for 1:2, 1:3, 1:4 and 1:6 input:output frequency ratios. The use of even dividers ensure that the output duty cycle is always 50%. Table 6 illustrates the various output

configurations, the table describes the outputs using the input clock frequency CLK as a reference.

The feedback divider division settings establish the output relationship, in addition, it must be ensured that the VCO will be stable given the frequency of the outputs desired. The feedback frequency should be used to situate the VCO into a frequency range in which the PLL will be stable. The design of the PLL supports output frequencies from 50 MHz to 200 MHz while the VCO frequency range is specified from 200 MHz to 400 MHz and should not be exceeded for stable operation.

Table 6: Output Frequency Relationship^a for QFB connected to FB_IN

Configuration Inputs				Input Frequency Range CLK [MHz]	Output Frequency Ratio and Range		
FSEL_FB	FSELA	FSELB	FSELC		Ratio, QAx [MHz]	Ratio, QBx [MHz]	Ratio, QCx [MHz]
0	0	0	0	25.0–50.0	4•CLK (100–200)	4•CLK (100–200)	4•CLK (100–200)
0	0	0	1		4•CLK (100–200)	4•CLK (100–200)	2•CLK (50.0–100)
0	0	1	0		4•CLK (100–200)	2•CLK (50.0–100)	4•CLK (100–200)
0	0	1	1		4•CLK (100–200)	2•CLK (50.0–100)	2•CLK (50.0–100)
0	1	0	0		2•CLK (50.0–100)	4•CLK (100–200)	4•CLK (100–200)
0	1	0	1		2•CLK (50.0–100)	4•CLK (100–200)	2•CLK (50.0–100)
0	1	1	0		2•CLK (50.0–100)	2•CLK (50.0–100)	4•CLK (100–200)
0	1	1	1		2•CLK (50.0–100)	2•CLK (50.0–100)	2•CLK (50.0–100)
1	0	0	0	16.67–33.33	6•CLK (100–200)	6•CLK (100–200)	6•CLK (100–200)
1	0	0	1		6•CLK (100–200)	6•CLK (100–200)	3•CLK (50.0–100)
1	0	1	0		6•CLK (100–200)	3•CLK (50.0–100)	6•CLK (100–200)
1	0	1	1		6•CLK (100–200)	3•CLK (50.0–100)	3•CLK (50.0–100)
1	1	0	0		3•CLK (50.0–100)	6•CLK (100–200)	6•CLK (100–200)
1	1	0	1		3•CLK (50.0–100)	6•CLK (100–200)	3•CLK (50.0–100)
1	1	1	0		3•CLK (50.0–100)	3•CLK (50.0–100)	6•CLK (100–200)
1	1	1	1		3•CLK (50.0–100)	3•CLK (50.0–100)	3•CLK (50.0–100)

a. Output frequency relationship with respect to input reference frequency CLK. The VCO frequency range is always 200–400.

Typical and Maximum Period Jitter Specification

Device Configuration	QA0 to QA6		QB0 to QB6		QC0 to QC6	
	Typ	Max	Typ	Max	Typ	Max
All output banks in ÷2 or ÷4 divider configuration ^a ÷2 (FSELA=0 and FESLB=0 and FSELC=0) ÷4 (FSELA=1 and FESLB=1 and FSELC=1)	25	50	50	70	25	50
	20	70	50	100	20	70
Mixed ÷2/ ÷4 divider configurations ^b for output banks in ÷2 divider configurations for output banks in ÷4 divider configurations	80	130	100	150	80	130
	25	70	60	100	25	70

a. In this configuration, all MPC9600 outputs generate the same clock frequency. See Figure 1 for an example configuration.

b. Multiple frequency generation. Jitter data are specified for each output divider separately. See Figure 2 for an example.

Typical and Maximum Cycle-to-cycle Jitter Specification

Device Configuration	QA0 to QA6		QB0 to QB6		QC0 to QC6	
	Typ	Max	Typ	Max	Typ	Max
All output banks in ÷2 or ÷4 divider configuration ^a ÷2 (FSELA=0 and FESLB=0 and FSELC=0) ÷4 (FSELA=1 and FESLB=1 and FSELC=1)	40	90	80	130	40	90
	40	110	120	180	40	110
Mixed ÷2/ ÷4 divider configurations ^b for output banks in ÷2 divider configurations for output banks in ÷4 divider configurations	150	250	200	280	150	250
	30	110	120	180	30	110

a. In this configuration, all MPC9600 outputs generate the same clock frequency.

b. Multiple frequency generation. Jitter data are specified for each output divider separately.

Figure 3. Configuration for 125 MHz clocks

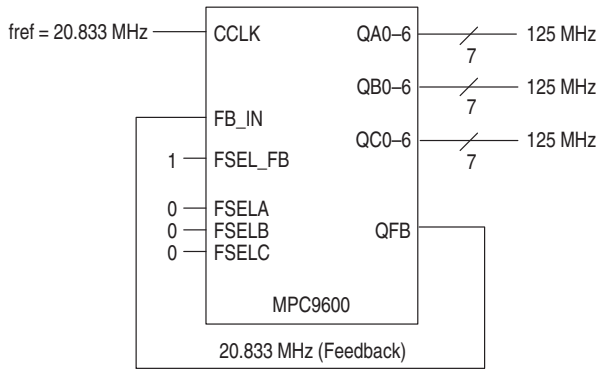

Frequency range	Min	Max
Input	16.67 MHz	33.33 MHz
QA outputs	100 MHz	200 MHz
QB outputs	100 MHz	200 MHz
QC outputs	100 MHz	200 MHz

Figure 4. Configuration for 133.3/66.67 MHz clocks

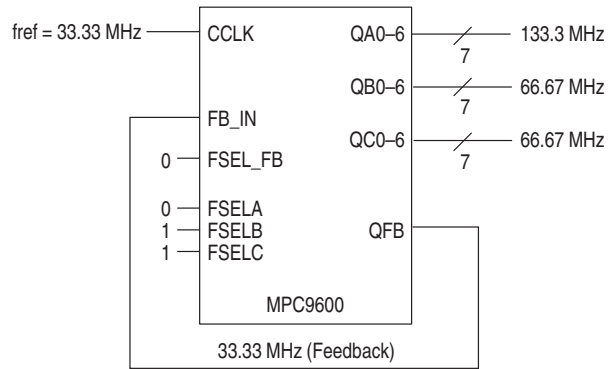

Frequency range	Min	Max
Input	25 MHz	50 MHz
QA outputs	100 MHz	200 MHz
QB outputs	100 MHz	200 MHz
QC outputs	100 MHz	200 MHz

Power Supply Filtering

The MPC9600 is a mixed analog/digital product. Its analog circuitry is naturally susceptible to random noise, especially if this noise is seen on the power supply pins. Random noise on the V_{CCA} (PLL) power supply impacts the device characteristics, for instance I/O jitter. The MPC9600 provides separate power supplies for the output buffers (V_{CC}) and the phase-locked loop (V_{CCA}) of the device. The purpose of this design technique is to isolate the high switching noise digital outputs from the relatively sensitive internal analog phase-locked loop. In a digital system environment where it is more difficult to minimize noise on the power supplies a second level of isolation may be required. The simple but effective form of isolation is a power supply filter on the V_{CCA} pin for the MPC9600. Figure 5. illustrates a typical power supply filter scheme. The MPC9600 frequency and phase stability is most susceptible to noise with spectral content in the 100kHz to 20MHz range. Therefore the filter should be designed to target this range. The key parameter that needs to be met in the final filter design is the DC voltage drop across the series filter resistor R_F . From the data sheet the I_{CCA} current (the current sourced through the V_{CCA} pin) is typically 3 mA (5 mA maximum), assuming that a minimum of 2.325 V ($V_{CC}=3.3$ V or $V_{CC}=2.5$ V) must be maintained on the V_{CCA} pin. The resistor R_F shown in Figure 5. "VCCA Power Supply Filter" must have a resistance of 9-10 Ω ($V_{CC}=2.5$ V) to meet the voltage drop criteria.

The minimum values for R_F and the filter capacitor C_F are defined by the required filter characteristics: the RC filter should provide an attenuation greater than 40 dB for noise whose spectral content is above 100 kHz. In the example RC filter shown in Figure 5. "VCCA Power Supply Filter", the filter cut-off frequency is around 3-5 kHz and the noise attenuation at 100 kHz is better than 42 dB.

$$R_F = 9-10 \Omega \text{ for } V_{CC} = 2.5 \text{ V or } V_{CC} = 3.3 \text{ V}$$

$$C_F = 22 \mu\text{F for } V_{CC} = 2.5 \text{ V or } V_{CC} = 3.3 \text{ V}$$

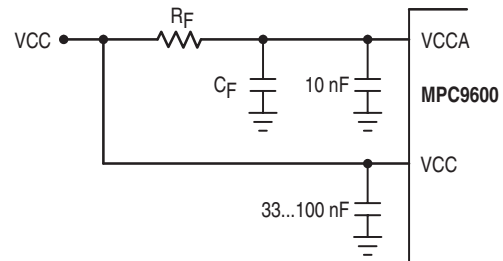

Figure 5. VCCA Power Supply Filter

As the noise frequency crosses the series resonant point of an individual capacitor its overall impedance begins to look inductive and thus increases with increasing frequency. The parallel capacitor combination shown ensures that a low impedance path to ground exists for frequencies well above the bandwidth of the PLL. Although the MPC9600 has several design features to minimize the susceptibility to power supply noise (isolated power and grounds and fully differential PLL) there still may be applications in which overall performance is being degraded due to system power supply noise. The power supply filter schemes discussed in this section should be adequate to eliminate power supply noise related problems in most designs.

Using the MPC9600 in zero-delay applications

Nested clock trees are typical applications for the MPC9600. For these applications the MPC9600 offers a differential LVPECL clock input pair as a PLL reference. This allows for the use of differential LVPECL primary clock distribution devices such as the Motorola MC100ES6111 or MC100ES6226, taking advantage of its superior low-skew performance. Clock trees using LVPECL for clock distribution and the MPC9600 as LVCMOS PLL fanout buffer with zero insertion delay will show significantly lower clock skew than clock distributions developed from CMOS fanout buffers.

The external feedback option of the MPC9600 PLL allows for its use as a zero delay buffer. The PLL aligns the feedback clock output edge with the clock input reference edge and virtually eliminates the propagation delay through the device.

The remaining insertion delay (skew error) of the MPC9600 in zero-delay applications is measured between the reference clock input and any output. This effective delay consists of the static phase offset (SPO or $t(\varnothing)$), I/O jitter ($t_{JIT}(\varnothing)$, phase or long-term jitter), feedback path delay and the output-to-output skew ($t_{SK(O)}$) relative to the feedback output.

Calculation of part-to-part skew

The MPC9600 zero delay buffer supports applications where critical clock signal timing can be maintained across several devices. If the reference clock inputs (CCLK or PCLK) of two or more MPC9600 are connected together, the maximum overall timing uncertainty from the common CCLK input to any output is:

$$t_{SK(PP)} = t(\varnothing) + t_{SK(O)} + t_{PD, LINE(FB)} + t_{JIT}(\varnothing) \cdot CF$$

This maximum timing uncertainty consist of 4 components: static phase offset, output skew, feedback board trace delay and I/O (phase) jitter:

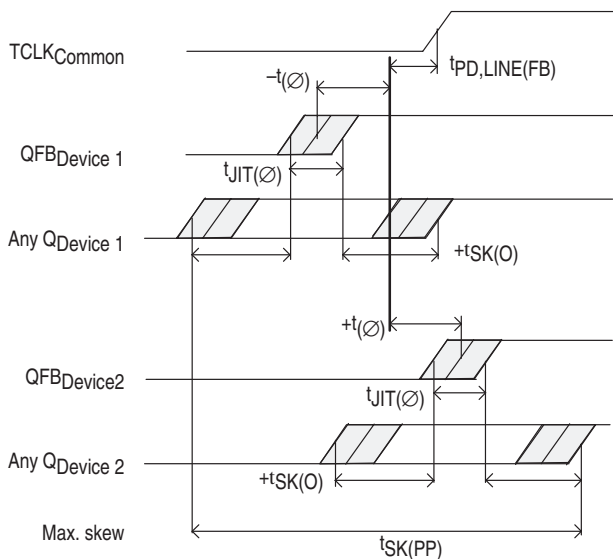

Figure 6. MPC9600 max. device-to-device skew

Due to the statistical nature of I/O jitter a RMS value (1σ) is specified. I/O jitter numbers for other confidence factors (CF) can be derived from Table 8.

Table 8: Confidence Factor CF

CF	Probability of clock edge within the distribution
$\pm 1\sigma$	0.68268948
$\pm 2\sigma$	0.95449988
$\pm 3\sigma$	0.99730007
$\pm 4\sigma$	0.99993663
$\pm 5\sigma$	0.99999943
$\pm 6\sigma$	0.99999999

The feedback trace delay is determined by the board layout and can be used to fine-tune the effective delay through each device. In the following example calculation a I/O jitter confidence factor of 99.7% ($\pm 3\sigma$) is assumed, resulting in a worst case timing uncertainty from input to any output of -261 ps to 341 ps relative to CCLK ($V_{CC}=3.3V$ and $f_{VCO} = 200$ MHz):

$$t_{SK(PP)} = [-60ps...140ps] + [-150ps...150ps] + [(17ps \cdot -3)...(17ps \cdot 3)] + t_{PD, LINE(FB)}$$

$$t_{SK(PP)} = [-261ps...341ps] + t_{PD, LINE(FB)}$$

Above equation uses the maximum I/O jitter number shown in the AC characteristic table for $V_{CC}=3.3V$ (17 ps RMS). I/O jitter is frequency dependant with a maximum at the lowest VCO frequency (200 MHz for the MPC9600). Applications using a higher VCO frequency exhibit less I/O jitter than the AC characteristic limit. The I/O jitter characteristics in Figure 7. can be used to derive a smaller I/O jitter number at the specific VCO frequency, resulting in tighter timing limits in zero-delay mode and for part-to-part skew $t_{SK(PP)}$.

Max. I/O Jitter versus frequency

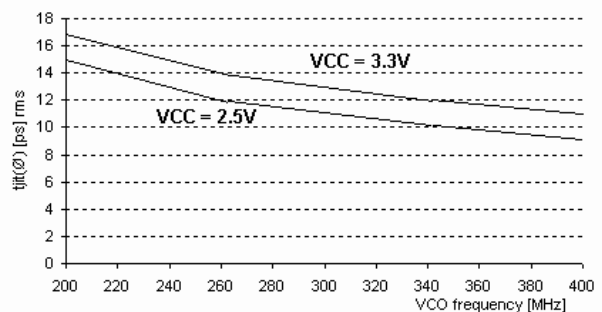

Figure 7. Max. I/O Jitter versus VCO frequency for $V_{CC}=2.5V$ and $V_{CC}=3.3V$

Driving Transmission Lines

The MPC9600 clock driver was designed to drive high speed signals in a terminated transmission line environment. To provide the optimum flexibility to the user the output drivers were designed to exhibit the lowest impedance possible. With an output impedance of less than $20\ \Omega$ the drivers can drive either parallel or series terminated transmission lines. For more information on transmission lines the reader is referred to Motorola application note AN1091. In most high performance clock networks point-to-point distribution of signals is the method of choice. In a point-to-point scheme either series terminated or parallel

terminated transmission lines can be used. The parallel technique terminates the signal at the end of the line with a 50Ω resistance to $V_{CC}+2$.

This technique draws a fairly high level of DC current and thus only a single terminated line can be driven by each output of the MPC9600 clock driver. For the series terminated case however there is no DC current draw, thus the outputs can drive multiple series terminated lines. Figure 8. "Single versus Dual Transmission Lines" illustrates an output driving a single series terminated line versus two series terminated lines in parallel. When taken to its extreme the fanout of the MPC9600 clock driver is effectively doubled due to its capability to drive multiple lines.

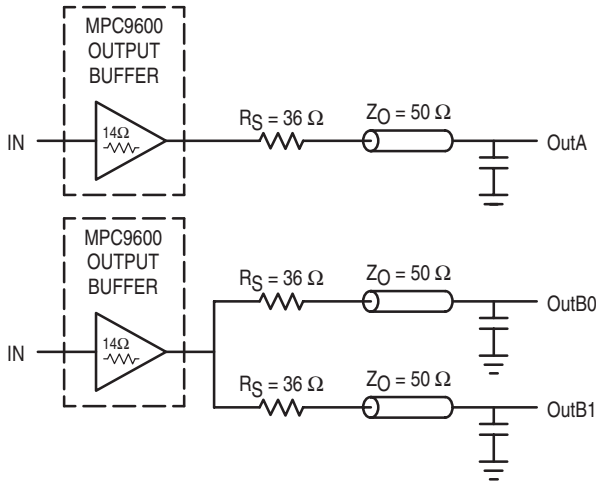

Figure 8. Single versus Dual Transmission Lines

The waveform plots in Figure 9. "Single versus Dual Line Termination Waveforms" show the simulation results of an output driving a single line versus two lines. In both cases the drive capability of the MPC9600 output buffer is more than sufficient to drive 50Ω transmission lines on the incident edge. Note from the delay measurements in the simulations a delta of only 43 ps exists between the two differently loaded outputs. This suggests that the dual line driving need not be used exclusively to maintain the tight output-to-output skew of the MPC9600. The output waveform in Figure 9. "Single versus Dual Line Termination Waveforms" shows a step in the waveform, this step is caused by the impedance mismatch seen looking into the driver. The parallel combination of the 36Ω series resistor plus the output impedance does not match the parallel combination of the line impedances. The voltage wave launched down the two lines will equal:

$$V_L = V_S (Z_0 \div (R_S + R_0 + Z_0))$$

$$\begin{aligned} Z_0 &= 50\Omega \parallel 50\Omega \\ R_S &= 36\Omega \parallel 36\Omega \\ R_0 &= 14\Omega \\ V_L &= 3.0 (25 \div (18+17+25)) \\ &= 1.31\text{ V} \end{aligned}$$

At the load end the voltage will double due to the near unity reflection coefficient, to 2.6 V. It will then increment towards the quiescent 3.0 V in steps separated by one round trip delay (in this case 4.0 ns).

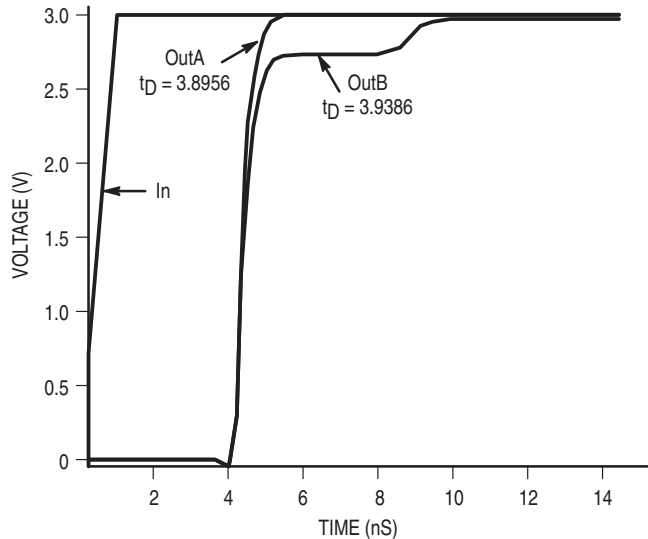

Figure 9. Single versus Dual Waveforms

Since this step is well above the threshold region it will not cause any false clock triggering, however designers may be uncomfortable with unwanted reflections on the line. To better match the impedances when driving multiple lines the situation in Figure 10. "Optimized Dual Line Termination" should be used. In this case the series terminating resistors are reduced such that when the parallel combination is added to the output buffer impedance the line impedance is perfectly matched.

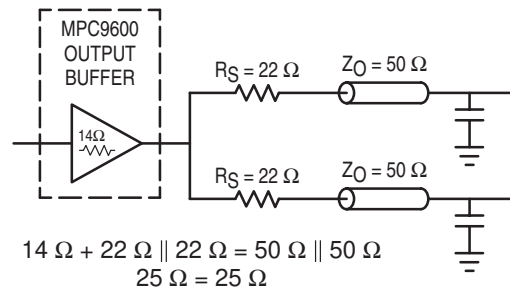

Figure 10. Optimized Dual Line Termination

The Following Figures Illustrate the Measurement Reference for the MPC9600 Clock Driver Circuit

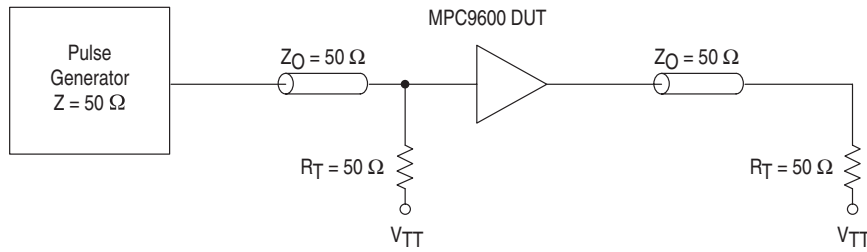

Figure 11. CCLK MPC9600 AC test reference

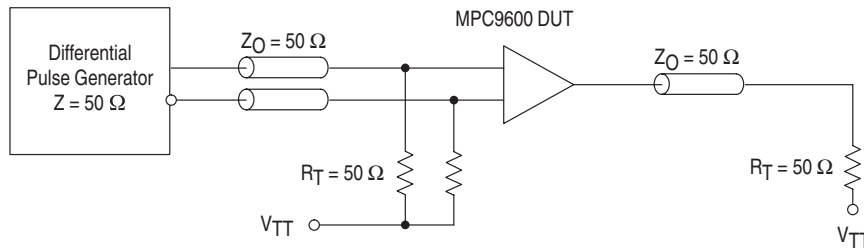

Figure 12. PCLK MPC9600 AC test reference

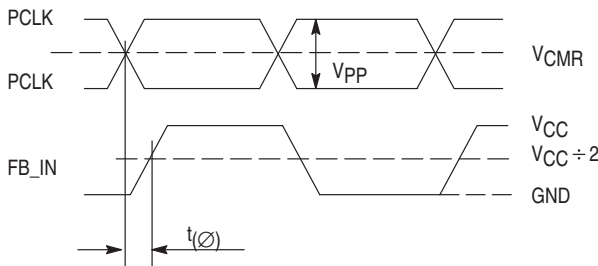

Figure 13. Propagation delay $t(\phi)$, static phase offset) test reference

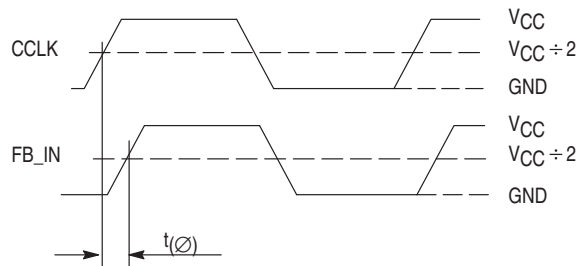
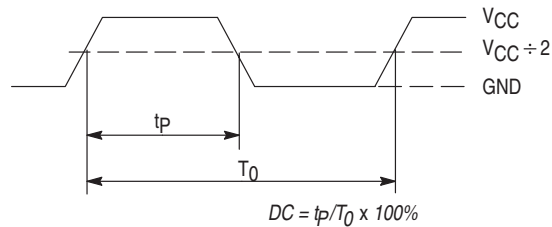
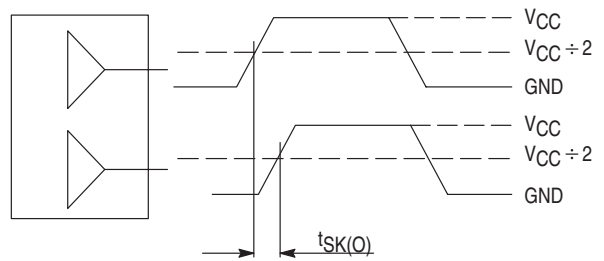

Figure 14. Propagation delay $t(\phi)$ test reference



The time from the PLL controlled edge to the non controlled edge, divided by the time between PLL controlled edges, expressed as a percentage

Figure 15. Output Duty Cycle (DC)



The pin-to-pin skew is defined as the worst case difference in propagation delay between any similar delay path within a single device

Figure 16. Output-to-output Skew $t_{SK}(O)$

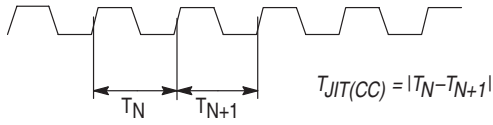

The variation in cycle time of a signal between adjacent cycles, over a random sample of adjacent cycle pairs

Figure 17. Cycle-to-cycle Jitter

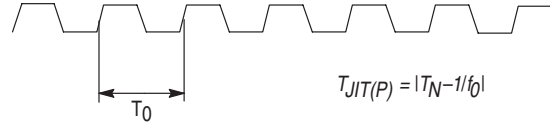

The deviation in cycle time of a signal with respect to the ideal period over a random sample of cycles

Figure 18. Period Jitter

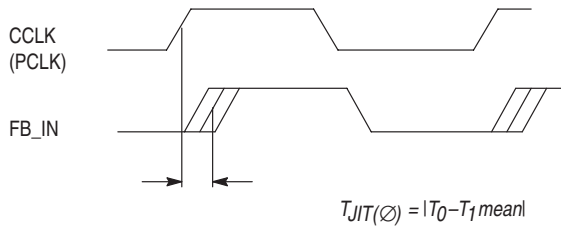

The deviation in t_0 for a controlled edge with respect to a t_0 mean in a random sample of cycles

Figure 19. I/O Jitter

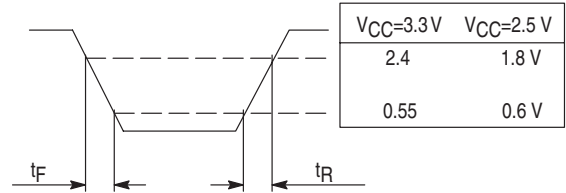
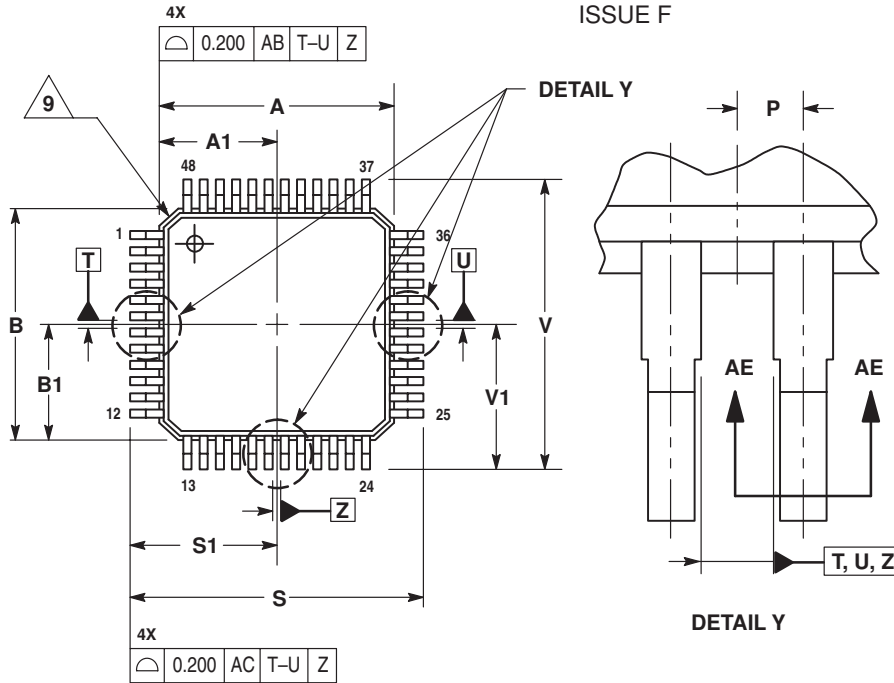

Figure 20. Output Transition Time Test Reference

OUTLINE DIMENSIONS

FA SUFFIX
LQFP PACKAGE
CASE 932-03
ISSUE F



- NOTES:
- DIMENSIONING AND TOLERANCING PER ASME Y14.5M, 1994.
 - CONTROLLING DIMENSION: MILLIMETER.
 - DATUM PLANE AB IS LOCATED AT BOTTOM OF LEAD AND IS COINCIDENT WITH THE LEAD WHERE THE LEAD EXITS THE PLASTIC BODY AT THE BOTTOM OF THE PARTING LINE.
 - DATUMS T, U, AND Z TO BE DETERMINED AT DATUM PLANE AB.
 - DIMENSIONS S AND V TO BE DETERMINED AT SEATING PLANE AC.
 - DIMENSIONS A AND B DO NOT INCLUDE MOLD PROTRUSION. ALLOWABLE PROTRUSION IS 0.250 PER SIDE. DIMENSIONS A AND B DO INCLUDE MOLD MISMATCH AND ARE DETERMINED AT DATUM PLANE AB.
 - DIMENSION D DOES NOT INCLUDE DAMBAR PROTRUSION. DAMBAR PROTRUSION SHALL NOT CAUSE THE D DIMENSION TO EXCEED 0.350.
 - MINIMUM SOLDER PLATE THICKNESS SHALL BE 0.0076.
- △ EXACT SHAPE OF EACH CORNER IS OPTIONAL.

DIM	MILLIMETERS	
	MIN	MAX
A	7.000	BSC
A1	3.500	BSC
B	7.000	BSC
B1	3.500	BSC
C	1.400	1.600
D	0.170	0.270
E	1.350	1.450
F	0.170	0.230
G	0.500	BSC
H	0.050	0.150
J	0.090	0.200
K	0.500	0.700
L	0°	7°
M	12°	REF
N	0.090	0.160
P	0.250	BSC
R	0.150	0.250
S	9.000	BSC
S1	4.500	BSC
V	9.000	BSC
V1	4.500	BSC
W	0.200	REF
AA	1.000	REF

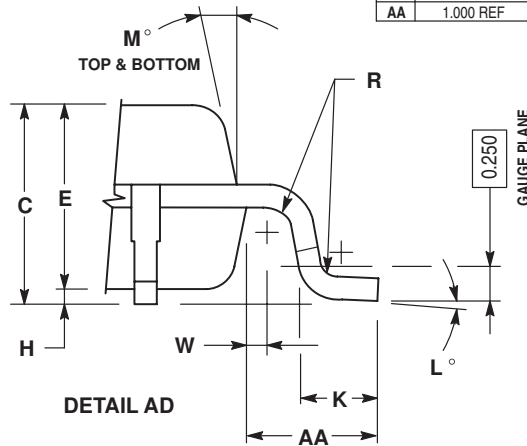
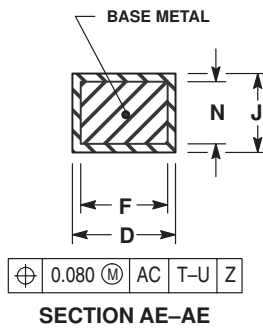
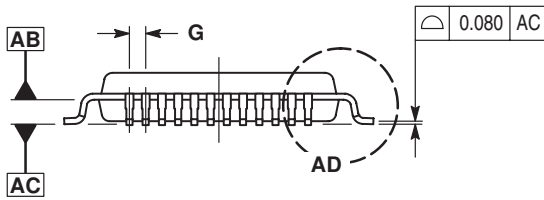

NOTES

NOTES

Motorola reserves the right to make changes without further notice to any products herein. Motorola makes no warranty, representation or guarantee regarding the suitability of its products for any particular purpose, nor does Motorola assume any liability arising out of the application or use of any product or circuit, and specifically disclaims any and all liability, including without limitation consequential or incidental damages. "Typical" parameters which may be provided in Motorola data sheets and/or specifications can and do vary in different applications and actual performance may vary over time. All operating parameters, including "Typicals" must be validated for each customer application by customer's technical experts. Motorola does not convey any license under its patent rights nor the rights of others. Motorola products are not designed, intended, or authorized for use as components in systems intended for surgical implant into the body, or other applications intended to support or sustain life, or for any other application in which the failure of the Motorola product could create a situation where personal injury or death may occur. Should Buyer purchase or use Motorola products for any such unintended or unauthorized application, Buyer shall indemnify and hold Motorola and its officers, employees, subsidiaries, affiliates, and distributors harmless against all claims, costs, damages, and expenses, and reasonable attorney fees arising out of, directly or indirectly, any claim of personal injury or death associated with such unintended or unauthorized use, even if such claim alleges that Motorola was negligent regarding the design or manufacture of the part. Motorola, Inc. Motorola, Inc. is an Equal Opportunity/Affirmative Action Employer. MOTOROLA and the  logo are registered in the US Patent & Trademark Office. All other product or service names are the property of their respective owners.

© Motorola, Inc. 2001.

How to reach us:

USA/EUROPE/Locations Not Listed: Motorola Literature Distribution; P.O. Box 5405, Denver, Colorado 80217. 1-303-675-2140 or 1-800-441-2447

JAPAN: Motorola Japan Ltd.; SPS, Technical Information Center, 3-20-1, Minami-Azabu. Minato-ku, Tokyo 106-8573 Japan. 81-3-3440-3569

ASIA/PACIFIC: Motorola Semiconductors H.K. Ltd.; Silicon Harbour Centre, 2 Dai King Street, Tai Po Industrial Estate, Tai Po, N.T., Hong Kong. 852-26668334

Technical Information Center: 1-800-521-6274

HOME PAGE: <http://www.motorola.com/semiconductors/>



MOTOROLA

**For More Information On This Product,
Go to: www.freescale.com**

MPC9600/D