



Chipsmall Limited consists of a professional team with an average of over 10 year of expertise in the distribution of electronic components. Based in Hongkong, we have already established firm and mutual-benefit business relationships with customers from,Europe,America and south Asia,supplying obsolete and hard-to-find components to meet their specific needs.

With the principle of “Quality Parts,Customers Priority,Honest Operation,and Considerate Service”,our business mainly focus on the distribution of electronic components. Line cards we deal with include Microchip,ALPS,ROHM,Xilinx,Pulse,ON,Everlight and Freescale. Main products comprise IC,Modules,Potentiometer,IC Socket,Relay,Connector.Our parts cover such applications as commercial,industrial, and automotives areas.

We are looking forward to setting up business relationship with you and hope to provide you with the best service and solution. Let us make a better world for our industry!



## Contact us

Tel: +86-755-8981 8866 Fax: +86-755-8427 6832

Email & Skype: info@chipsmall.com Web: www.chipsmall.com

Address: A1208, Overseas Decoration Building, #122 Zhenhua RD., Futian, Shenzhen, China

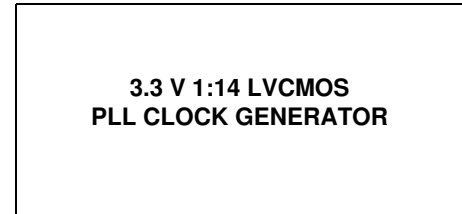


## 3.3 V 1:14 LVCMOS PLL Clock Generator

The MPC9774 is a 3.3 V compatible, 1:14 PLL based clock generator targeted for high performance low-skew clock distribution in mid-range to high-performance networking, computing and telecom applications. With output frequencies up to 125 MHz and output skews less than 175 ps the device meets the needs of the most demanding clock applications.

### Features

- 1:14 PLL Based Low-Voltage Clock Generator
- 3.3 V Power Supply
- Internal Power-On Reset
- Generates Clock Signals Up to 125 MHz
- Maximum Output Skew of 175 ps
- Two LVCMOS PLL Reference Clock Inputs
- External PLL Feedback Supports Zero-Delay Capability
- Various Feedback and Output Dividers (See [Applications Information](#))
- Supports Up to Three Individual Generated Output Clock Frequencies
- Drives Up to 28 Clock Lines
- Ambient Temperature Range 0°C to +70°C
- Pin and Function Compatible to the MPC974
- 52-Lead LQFP Package, Pb-free
- **For drop in replacement use 87974**



The MPC9774 utilizes PLL technology to frequency lock its outputs onto an input reference clock. Normal operation of the MPC9774 requires the connection of the PLL feedback output QFB to feedback input FB\_IN to close the PLL feedback path. The reference clock frequency and the divider for the feedback path determine the VCO frequency. Both must be selected to match the VCO frequency range.

The MPC9774 features frequency programmability between the three output banks outputs as well as the output to input relationships. Output frequency ratios of 1:1, 2:1, 3:1, 3:2 and 3:2:1 can be realized. Additionally, the device supports a separate configurable feedback output which allows for a wide variety of input/output frequency multiplication alternatives. The VCO\_SEL pin provides an extended PLL input reference frequency range.

The REF\_SEL pin selects the internal crystal oscillator or the LVCMOS compatible inputs as the reference clock signal. Two alternative LVCMOS compatible clock inputs are provided for clock redundancy support. The PLL\_EN control selects the PLL bypass configuration for test and diagnosis. In this configuration, the selected input reference clock is routed directly to the output dividers bypassing the PLL. The PLL bypass is fully static and the minimum clock frequency specification and all other PLL characteristics do not apply.

The MPC9774 has an internal power-on reset.

The MPC9774 is fully 3.3 V compatible and requires no external loop filter components. All inputs (except XTAL) accept LVCMOS signals while the outputs provide LVCMOS compatible levels with the capability to drive terminated 50 Ω transmission lines. For series terminated transmission lines, each of the MPC9774 outputs can drive one or two traces giving the devices an effective fanout of 1:12. The device is pin and function compatible to the MPC974 and is packaged in a 52-lead LQFP package.

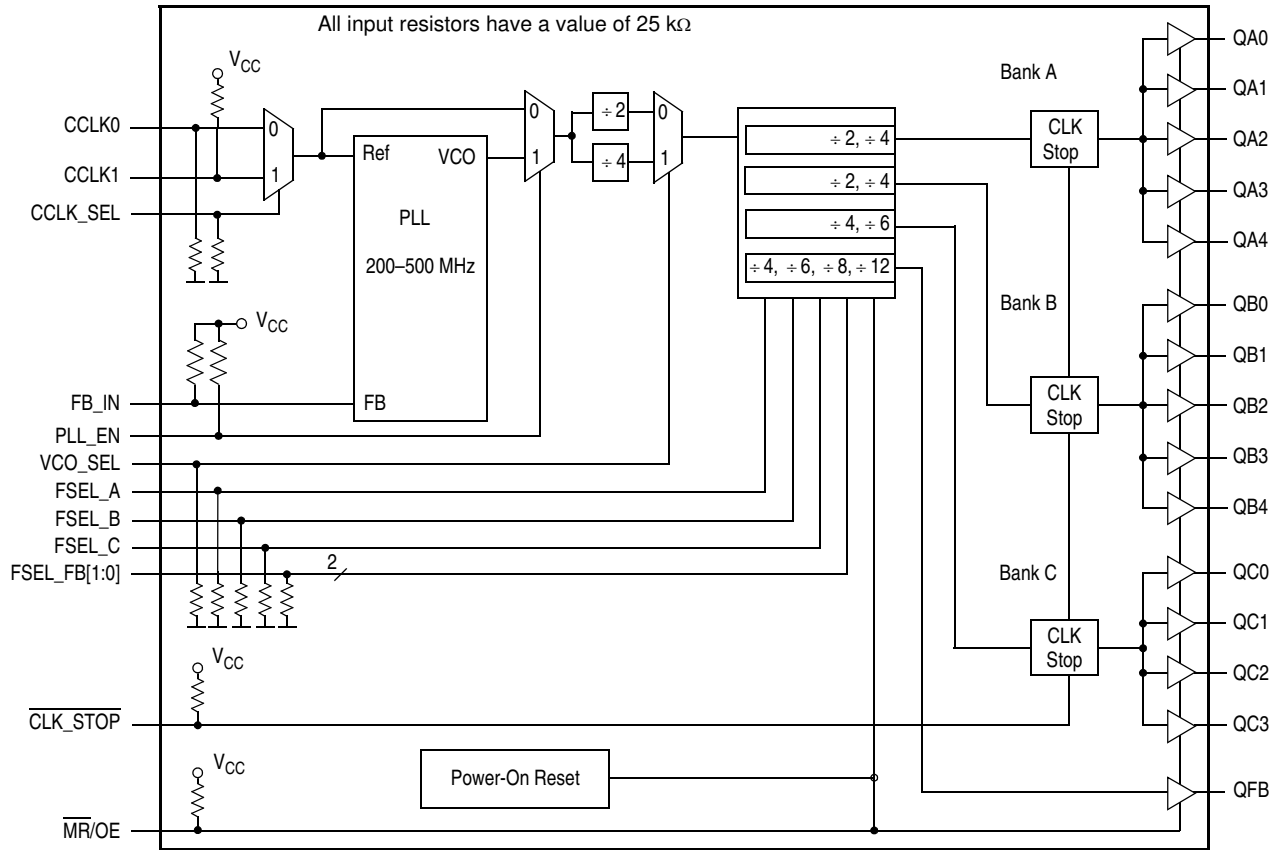


Figure 1. MPC9774 Logic Diagram

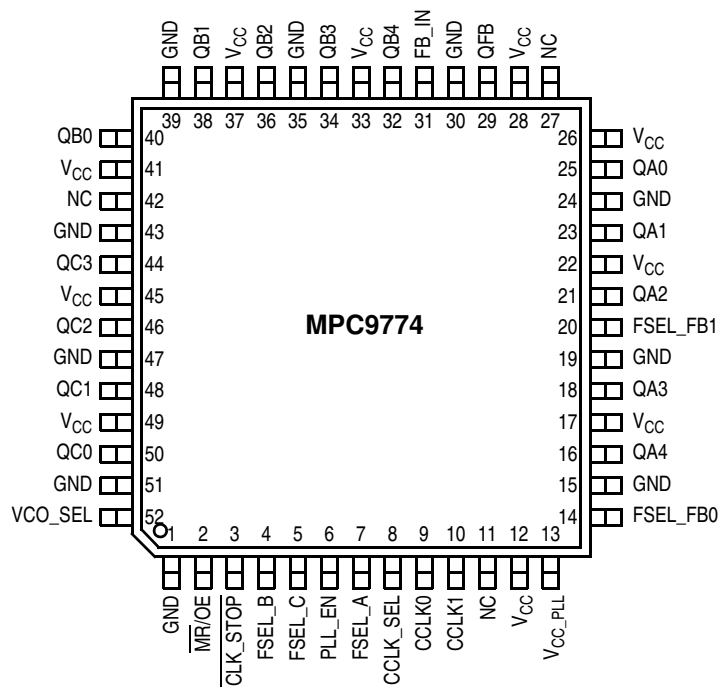


Figure 2. MPC9774 52-Lead Package Pinout (Top View)

**Table 1. Pin Configuration**

Pin	I/O	Type	Function
CCLK0	Input	LVCMOS	PLL reference clock
CCLK1	Input	LVCMOS	Alternative PLL reference clock
FB_IN	Input	LVCMOS	PLL feedback signal input, connect to QFB
CCLK_SEL	Input	LVCMOS	LVCMOS clock reference select
VCO_SEL	Input	LVCMOS	VCO operating frequency select
PLL_EN	Input	LVCMOS	PLL enable/PLL bypass mode select
$\overline{\text{MR/OE}}$	Input	LVCMOS	Output enable/disable (high-impedance tristate) and device reset
$\overline{\text{CLK\_STOP}}$	Input	LVCMOS	Output enable/clock stop (logic low state)
FSEL_A	Input	LVCMOS	Frequency divider select for bank A outputs
FSEL_B	Input	LVCMOS	Frequency divider select for bank B outputs
FSEL_C	Input	LVCMOS	Frequency divider select for bank C outputs
FSEL_FB[1:0]	Input	LVCMOS	Frequency divider select for the QFB output
QA[4:0]	Output	LVCMOS	Clock outputs (Bank A)
QB[4:0]	Output	LVCMOS	Clock outputs (Bank B)
QC[3:0]	Output	LVCMOS	Clock outputs (Bank C)
QFB	Output	LVCMOS	PLL feedback output. Connect to FB_IN.
GND	Supply	Ground	Negative power supply
V <sub>CC_PLL</sub>	Supply	V <sub>CC</sub>	PLL positive power supply (analog power supply). It is recommended to use an external RC filter for the analog power supply pin V <sub>CC_PLL</sub> . Please see applications section for details.
V <sub>CC</sub>	Supply	V <sub>CC</sub>	Positive power supply for I/O and core. All V <sub>CC</sub> pins must be connected to the positive power supply for correct operation

**Table 2. Function Table (Configuration Controls)**

Control	Default	0	1
CCLK_SEL	0	Selects CCLK0 as PLL references signal input	Selects CCLK1 as PLL reference signal input
VCO_SEL	0	Selects VCO ÷ 2. The VCO frequency is scaled by a factor of 2 (high input frequency range)	Selects VCO ÷ 4. The VCO frequency is scaled by a factor of 4 (low input frequency range).
PLL_EN	1	Test mode with the PLL bypassed. The reference clock is substituted for the internal VCO output. MPC9774 is fully static and no minimum frequency limit applies. All PLL related AC characteristics are not applicable.	Normal operation mode with PLL enabled.
$\overline{\text{CLK\_STOP}}$	1	QA, QB an QC outputs disabled in logic low state. QFB is not affected by $\overline{\text{CLK\_STOP}}$ . $\overline{\text{CLK\_STOP}}$ deassertion may cause the initial output clock pulse to be distorted.	Outputs enabled (active)
$\overline{\text{MR/OE}}$	1	Outputs disabled (high-impedance state) and reset of the device. During reset/output disable the PLL feedback loop is open and the internal VCO is tied to its lowest frequency. The MPC9774 requires reset after any loss of PLL lock. Loss of PLL lock may occur when the external feedback path is interrupted. The length of the reset pulse should be greater than one reference clock cycle (CCLKx). The device is reset by the internal power-on reset (POR) circuitry during power-up.	Outputs enabled (active)

**Table 2. Function Table (Configuration Controls)**

Control	Default	0	1
---------	---------	---	---

VCO\_SEL, FSEL\_A, FSEL\_B, FSEL\_C and FSEL\_FB[1:0] control the operating PLL frequency range and input/output frequency ratios. See Table 3 and Table 4 for the device frequency configuration.

**Table 3. Function Table (Output Dividers Bank A, B, and C)**

VCO_SEL	FSEL_A	QA[4:0]	VCO_SEL	FSEL_B	QB[4:0]	VCO_SEL	FSEL_C	QC[3:0]
0	0	VCO ÷ 4	0	0	VCO ÷ 4	0	0	VCO ÷ 8
0	1	VCO ÷ 8	0	1	VCO ÷ 8	0	1	VCO ÷ 12
1	0	VCO ÷ 8	1	0	VCO ÷ 8	1	0	VCO ÷ 16
1	1	VCO ÷ 16	1	1	VCO ÷ 16	1	1	VCO ÷ 24

**Table 4. Function Table (QFB)**

VCO_SEL	FSEL_B1	FSEL_B0	QFB
0	0	0	VCO ÷ 8
0	0	1	VCO ÷ 16
0	1	0	VCO ÷ 12
0	1	1	VCO ÷ 24
1	0	0	VCO ÷ 16
1	0	1	VCO ÷ 32
1	1	0	VCO ÷ 24
1	1	1	VCO ÷ 48

**Table 5. General Specifications**

Symbol	Characteristics	Min	Typ	Max	Unit	Condition
V <sub>TT</sub>	Output Termination Voltage		V <sub>CC</sub> ÷ 2		V	
MM	ESD protection (Machine Model)	200			V	
HBM	ESD protection (Human Body Model)	2000			V	
LU	Latch-Up Immunity	200			mA	
C <sub>PD</sub>	Power Dissipation Capacitance		12		pF	Per output
C <sub>IN</sub>	Input Capacitance		4.0		pF	Inputs

**Table 6. Absolute Maximum Ratings<sup>(1)</sup>**

Symbol	Characteristics	Min	Max	Unit
V <sub>CC</sub>	Supply Voltage	-0.3	3.9	V
V <sub>IN</sub>	DC Input Voltage	-0.3	V <sub>CC</sub> + 0.3	V
V <sub>OUT</sub>	DC Output Voltage	-0.3	V <sub>CC</sub> + 0.3	V
I <sub>IN</sub>	DC Input Current		±20	mA
I <sub>OUT</sub>	DC Output Current		±50	mA
T <sub>S</sub>	Storage Temperature	-65	125	°C

1. Absolute maximum continuous ratings are those maximum values beyond which damage to the device may occur. Exposure to these conditions or conditions beyond those indicated may adversely affect device reliability. Functional operation at absolute-maximum-rated conditions is not implied.

**Table 7. DC Characteristics** ( $V_{CC} = 3.3 \text{ V} \pm 5\%$ ,  $T_A = 0^\circ\text{C}$  to  $+70^\circ\text{C}$ )

Symbol	Characteristics	Min	Typ	Max	Unit	Condition
$V_{CC\_PLL}$	PLL Supply Voltage	3.02		$V_{CC}$	V	LVCMOS
$V_{IH}$	Input High Voltage	2.0		$V_{CC} + 0.3$	V	LVCMOS
$V_{IL}$	Input Low Voltage			0.8	V	LVCMOS
$V_{OH}$	Output High Voltage	2.4			V	$I_{OH} = -24 \text{ mA}^{(1)}$
$V_{OL}$	Output Low Voltage			0.55 0.30	V V	$I_{OL} = 24 \text{ mA}$ $I_{OL} = 12 \text{ mA}$
$Z_{OUT}$	Output Impedance		14 – 17		W	
$I_{IN}$	Input Current <sup>(2)</sup>			$\pm 200$	$\mu\text{A}$	$V_{IN} = V_{CC}$ or GND
$I_{CC\_PLL}$	Maximum PLL Supply Current		5.0	7.5	mA	$V_{CC\_PLL}$ Pin
$I_{CCQ}$	Maximum Quiescent Supply Current			8.0	mA	All $V_{CC}$ Pins

- The MPC9774 is capable of driving  $50 \Omega$  transmission lines on the incident edge. Each output drives one  $50 \Omega$  parallel terminated transmission line to a termination voltage of  $V_{TT}$ . Alternatively, the device drives up to two  $50 \Omega$  series terminated transmission lines.
- Inputs have pull-down or pull-up resistors affecting the input current.

**Table 8. AC Characteristics** ( $V_{CC} = 3.3 \text{ V} \pm 5\%$ ,  $T_A = 0^\circ\text{C}$  to  $+70^\circ\text{C}$ )<sup>(1)</sup>

Symbol	Characteristics	Min	Typ	Max	Unit	Condition
$f_{REF}$	Input Reference Frequency	$\div 8$ feedback	25.0	62.5	MHz	PLL locked
		$\div 12$ feedback	16.6	41.6	MHz	
		$\div 16$ feedback	12.5	31.25	MHz	
		$\div 24$ feedback	8.33	20.83	MHz	
		$\div 32$ feedback	6.25	15.625	MHz	
	$\div 48$ feedback	4.16	10.41	MHz	PLL bypass	
	Input Reference Frequency in PLL Bypass Mode <sup>(2)</sup>			250	MHz	
$f_{VCO}$	VCO Frequency Range <sup>(3)</sup>	200		500	MHz	
$f_{MAX}$	Output Frequency	$\div 4$ output	50.0	125.0	MHz	PLL locked
		$\div 8$ output	25.0	62.5	MHz	
		$\div 12$ output	16.6	41.6	MHz	
		$\div 16$ output	12.5	31.25	MHz	
		$\div 24$ output	8.33	20.83	MHz	
$t_{PW,MIN}$	Input Reference Pulse Width <sup>(4)</sup>	2.0			ns	
$t_R, t_F$	CCLKx Input Rise/Fall Time			1.0	ns	0.8 to 2.0 V
$t_{(\phi)}$	Propagation Delay (static phase offset) <sup>(5)</sup> CCLKx to FB_IN (FB = $\div 8$ and $f_{REF} = 50 \text{ MHz}$ )	-250		+100	ps	PLL locked
$t_{SK(O)}$	Output-to-Output Skew <sup>(6)</sup>	within QA bank		100	ps	
		within QB bank		125	ps	
		within QC bank		100	ps	
		any output		175	ps	
DC	Output Duty Cycle	47	50	53	%	
$t_R, t_F$	Output Rise/Fall Time	0.1		1.0	ns	0.55 to 2.4 V
$t_{PLZ, HZ}$	Output Disable Time			10	ns	
$t_{PZL}$	Output Enable Time			10	ns	
$t_{JIT(CC)}$	Cycle-to-Cycle Jitter <sup>(7)</sup>			90	ps	
$t_{JIT(PER)}$	Period Jitter <sup>(6)</sup>			90	ps	

**Table 8. AC Characteristics** ( $V_{CC} = 3.3 \text{ V} \pm 5\%$ ,  $T_A = 0^\circ\text{C}$  to  $+70^\circ\text{C}$ )<sup>(1)</sup> (Continued)

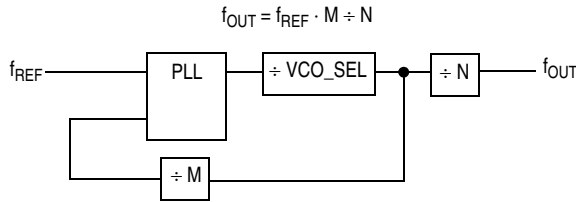
Symbol	Characteristics	Min	Typ	Max	Unit	Condition
$t_{\text{JIT}(\varnothing)}$	I/O Phase Jitter RMS ( $1 \sigma$ ) <sup>(8)</sup> FB = ÷ 8 FB = ÷ 12 FB = ÷ 16 FB = ÷ 24 FB = ÷ 32 FB = ÷ 48			15 49 18 22 26 34	ps ps ps ps ps ps	
BW	PLL Closed Loop Bandwidth <sup>(9)</sup> FB = ÷ 8 FB = ÷ 12 FB = ÷ 16 FB = ÷ 24 FB = ÷ 32 FB = ÷ 48		0.50 – 1.80 0.30 – 1.00 0.25 – 0.70 0.17 – 0.40 0.12 – 0.30 0.07 – 0.20		MHz MHz MHz MHz MHz MHz	
$t_{\text{LOCK}}$	Maximum PLL Lock Time			10	ms	

- AC characteristics apply for parallel output termination of  $50 \Omega$  to  $V_{TT}$ .
- In bypass mode, the MPC9774 divides the input reference clock.
- The input reference frequency must match the VCO lock range divided by the total feedback divider ratio (FB):  $f_{\text{REF}} = f_{\text{VCO}} \div (M \cdot \text{VCO\_SEL})$ .
- Calculation of reference duty cycle limits:  $\text{DC}_{\text{REF,MIN}} = t_{\text{PW,MIN}} \cdot f_{\text{REF}} \cdot 100\%$  and  $\text{DC}_{\text{REF,MAX}} = 100\% - \text{DC}_{\text{REF,MIN}}$ . E.g. at  $f_{\text{REF}} = 62.5 \text{ MHz}$  the input duty cycle range is  $12.5\% < \text{DC} < 87.5\%$ .
- Static phase offset depends on the reference frequency:  $t_{(\varnothing)} = +50 \text{ ps} \pm (1 \div (120 \cdot f_{\text{REF}}))$  for any reference frequency.
- Refer to Application section for part-to-part skew calculation.
- Valid for all outputs at the same frequency.
- I/O jitter for  $f_{\text{VCO}} = 400 \text{ MHz}$ . Refer to [Applications Information](#) for I/O jitter at other frequencies and for a jitter calculation for confidence factors other than  $1 \sigma$ .
- 3 dB point of PLL transfer characteristics.

## APPLICATIONS INFORMATION

## MPC9774 Configurations

Configuring the MPC9774 amounts to properly configuring the internal dividers to produce the desired output frequencies. The output frequency can be represented by this formula:



where  $f_{REF}$  is the reference frequency of the selected input clock source (CCLK0 or CCLK1), M is the PLL feedback divider and N is a output divider. M is configured by the FSEL\_FB[0:1] and N is individually configured for each output bank by the FSEL\_A, FSEL\_B and FSEL\_C inputs.

The reference frequency  $f_{REF}$  and the selection of the feedback-divider M is limited by the specified VCO frequency range.  $f_{REF}$  and M must be configured to match the VCO frequency range of 200 to 500 MHz in order to achieve stable PLL operation:

$$f_{VCO,MIN} \leq (f_{REF} \cdot VCO\_SEL \cdot M) \leq f_{VCO,MAX}$$

The PLL post-divider VCO\_SEL is either a divide-by-two or a divide-by-four and can be used to situate the VCO into the specified frequency range. This divider is controlled by the VCO\_SEL pin. VCO\_SEL effectively extends the usable input frequency range while it has no effect on the output to reference frequency ratio. The output frequency for each bank can be derived from the VCO frequency and output divider:

$$f_{QA[4:0]} = f_{VCO} \div (VCO\_SEL \cdot N_A)$$

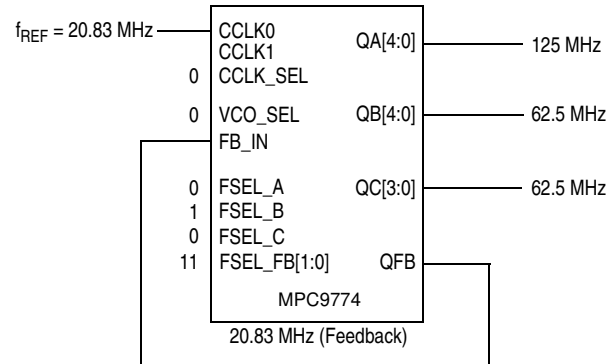
$$f_{QB[4:0]} = f_{VCO} \div (VCO\_SEL \cdot N_B)$$

$$f_{QC[3:0]} = f_{VCO} \div (VCO\_SEL \cdot N_C)$$

Table 9. MPC9774 Divider

Divider	Function	VCO_SEL	Values
M	PLL Feedback FSEL_FB[0:1]	÷ 2	8, 12, 16, 24
		÷ 4	16, 24, 32, 48
N <sub>A</sub>	Bank A Output Divider FSEL_A	÷ 2	4, 8
		÷ 4	8, 16
N <sub>B</sub>	Bank B Output Divider FSEL_B	÷ 2	4, 8
		÷ 4	8, 16
N <sub>C</sub>	Bank C Output Divider FSEL_C	÷ 2	8, 12
		÷ 4	16, 24

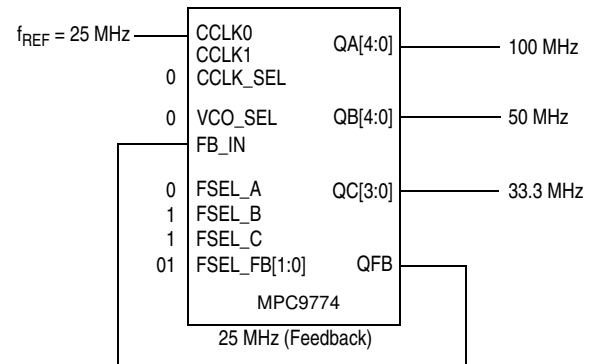
Table 9 shows the various PLL feedback and output dividers. The output dividers for the three output banks allow the user to configure the outputs into 1:1, 2:1, 3:2, and 3:2:1 frequency ratios. Figure 3 and Figure 4 display example configurations for the MPC9774.



MPC9774 example configuration (feedback of QFB = 20.83 MHz, VCO\_SEL = ÷ 2, M = 12, N<sub>A</sub> = 2, N<sub>B</sub> = 4, N<sub>C</sub> = 4,  $f_{VCO}$  = 500 MHz).

Frequency Range	Min	Max
Input	8.33 MHz	20.83 MHz
QA outputs	50 MHz	125 MHz
QB outputs	25 MHz	62.5 MHz
QC outputs	25 MHz	62.5 MHz

Figure 3. Example Configuration



MPC9774 example configuration (feedback of QFB = 25 MHz, VCO\_SEL = ÷ 2, M = 8, N<sub>A</sub> = 2, N<sub>B</sub> = 4, N<sub>C</sub> = 6,  $f_{VCO}$  = 400 MHz).

Frequency Range	Min	Max
Input	20 MHz	48 MHz
QA outputs	50 MHz	120 MHz
QB outputs	50 MHz	120 MHz
QC outputs	100 MHz	200 MHz

Figure 4. Example Configuration

**Using the MPC9774 in Zero-Delay Applications**

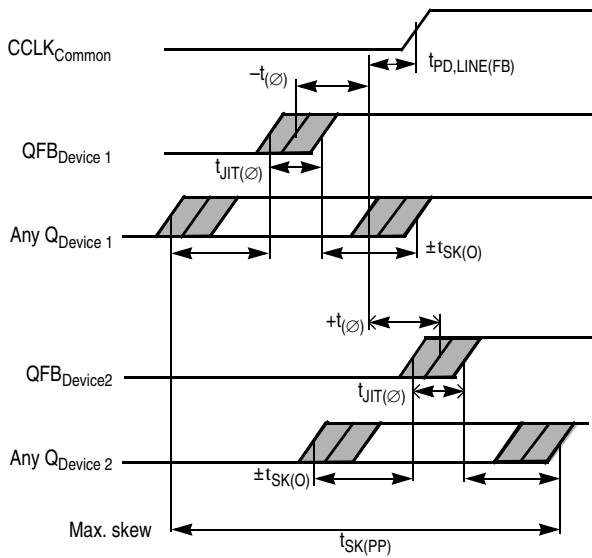
Nested clock trees are typical applications for the MPC9774. Designs using the MPC9774 as LVCMOS PLL fanout buffer with zero insertion delay will show significantly lower clock skew than clock distributions developed from CMOS fanout buffers. The external feedback of the MPC9774 clock driver allows for its use as a zero delay buffer. The PLL aligns the feedback clock output edge with the clock input reference edge resulting a near zero delay through the device (the propagation delay through the device is virtually eliminated). The maximum insertion delay of the device in zero-delay applications is measured between the reference clock input and any output. This effective delay consists of the static phase offset, I/O jitter (phase or long-term jitter), feedback path delay and the output-to-output skew error relative to the feedback output.

**Calculation of Part-to-Part Skew**

The MPC9774 zero delay buffer supports applications where critical clock signal timing can be maintained across several devices. If the reference clock inputs of two or more MPC9774 are connected together, the maximum overall timing uncertainty from the common CCLK input to any output is:

$$t_{SK(PP)} = t_{(\varnothing)} + t_{SK(O)} + t_{PD, LINE(FB)} + t_{JIT(\varnothing)} \cdot CF$$

This maximum timing uncertainty consist of 4 components: static phase offset, output skew, feedback board trace delay and I/O (phase) jitter:



**Figure 5. MPC9774 Maximum Device-to-Device Skew**

Due to the statistical nature of I/O jitter a RMS value ( $1 \sigma$ ) is specified. I/O jitter numbers for other confidence factors (CF) can be derived from Table 10.

The feedback trace delay is determined by the board layout and can be used to fine-tune the effective delay through each device.

**Table 10. Confidence Factor CF**

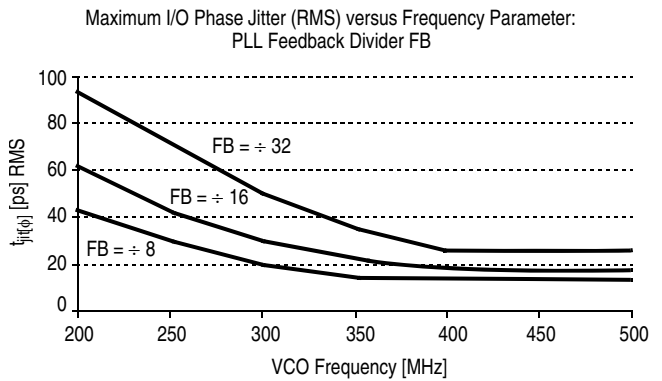
CF	Probability of Clock Edge within the Distribution
$\pm 1\sigma$	0.68268948
$\pm 2\sigma$	0.95449988
$\pm 3\sigma$	0.99730007
$\pm 4\sigma$	0.99993663
$\pm 5\sigma$	0.99999943
$\pm 6\sigma$	0.99999999

Due to the frequency dependence of the static phase offset and I/O jitter, using Figure 6 and Figure 7 to predict a maximum I/O jitter and the specified  $t_{(\varnothing)}$  parameter relative to the input reference frequency results in a precise timing performance analysis.

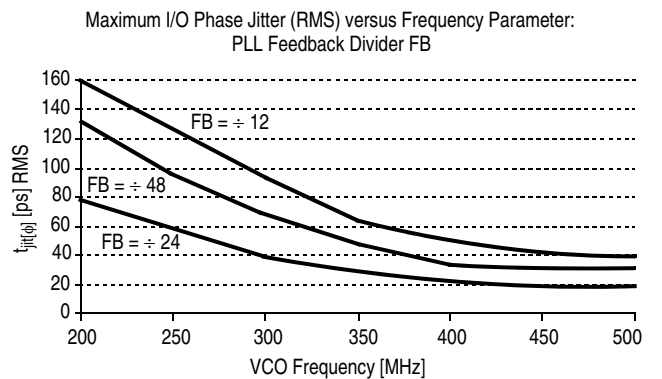
In the following example calculation a I/O jitter confidence factor of 99.7% ( $\pm 3\sigma$ ) is assumed, resulting in a worst case timing uncertainty from the common input reference clock to any output of  $-470$  ps to  $+320$  ps relative to CCLK (PLL feedback =  $\div 8$ , reference frequency = 50 MHz, VCO frequency = 400 MHz, I/O jitter = 15 ps RMS max., static phase offset  $t_{(\varnothing)} = -250$  ps to  $+100$  ps):

$$t_{SK(PP)} = [-250 \text{ ps} \dots +100 \text{ ps}] + [-175 \text{ ps} \dots 175 \text{ ps}] + [(15 \text{ ps} \cdot -3) \dots (15 \text{ ps} \cdot 3)] + t_{PD, LINE(FB)}$$

$$t_{SK(PP)} = [-470 \text{ ps} \dots +320 \text{ ps}] + t_{PD, LINE(FB)}$$



**Figure 6. MPC9774 I/O Jitter**

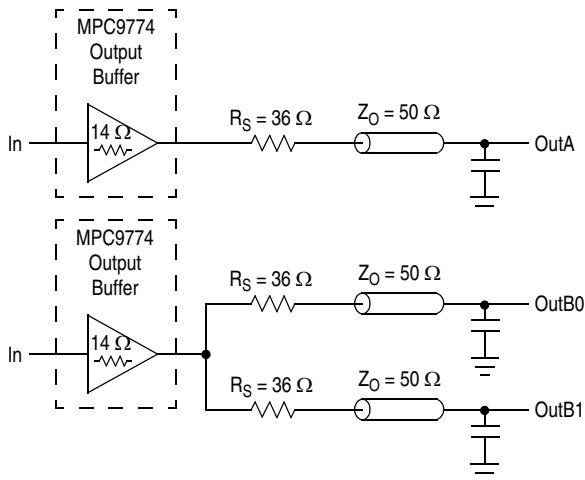


**Figure 7. MPC9774 I/O Jitter**

### Driving Transmission Lines

The MPC9774 clock driver was designed to drive high speed signals in a terminated transmission line environment. To provide the optimum flexibility to the user the output drivers were designed to exhibit the lowest impedance possible. With an output impedance of less than 20  $\Omega$  the drivers can drive either parallel or series terminated transmission lines. For more information on transmission lines the reader is referred to Freescale Semiconductor application note AN1091. In most high performance clock networks point-to-point distribution of signals is the method of choice. In a point-to-point scheme either series terminated or parallel terminated transmission lines can be used. The parallel technique terminates the signal at the end of the line with a 50  $\Omega$  resistance to  $V_{CC} \div 2$ .

This technique draws a fairly high level of DC current and thus only a single terminated line can be driven by each output of the MPC9774 clock driver. For the series terminated case however there is no DC current draw, thus the outputs can drive multiple series terminated lines. Figure 8 illustrates an output driving a single series terminated line versus two series terminated lines in parallel. When taken to its extreme the fanout of the MPC9774 clock driver is effectively doubled due to its capability to drive multiple lines.



**Figure 8. Single versus Dual Transmission Lines**

The waveform plots in Figure 9 show the simulation results of an output driving a single line versus two lines. In both cases the drive capability of the MPC9774 output buffer is more than sufficient to drive 50  $\Omega$  transmission lines on the incident edge. Note from the delay measurements in the simulations a delta of only 43 ps exists between the two differently loaded outputs. This suggests that the dual line driving need not be used exclusively to maintain the tight output-to-output skew of the MPC9774. The output waveform in Figure 9 shows a step in the waveform, this step is caused by the impedance mismatch seen looking into the driver. The parallel combination of the 36  $\Omega$  series resistor plus the output impedance does not match the parallel combination of the line impedances. The voltage wave launched down the two lines will equal:

$$V_L = V_S (Z_0 \div (R_S + R_0 + Z_0))$$

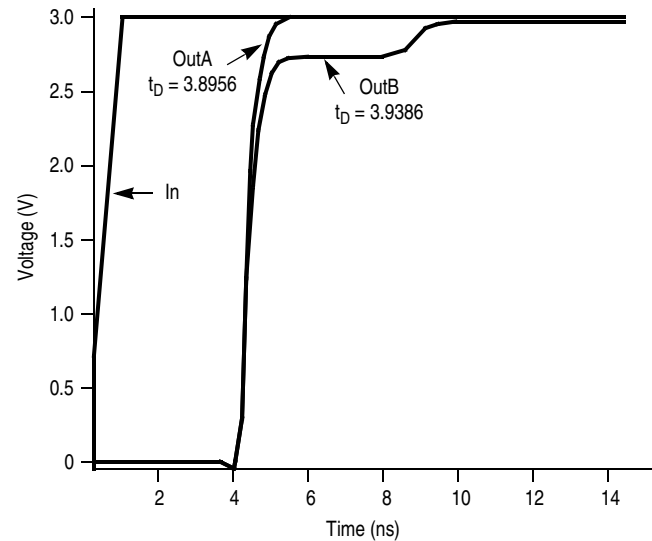
$$Z_0 = 50 \Omega \parallel 50 \Omega$$

$$R_S = 36 \Omega \parallel 36 \Omega$$

$$R_0 = 14 \Omega$$

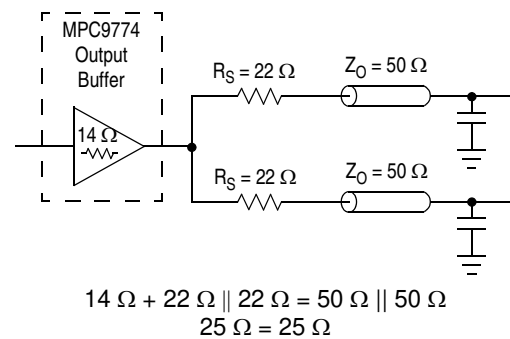
$$V_L = 3.0 (25 \div (18 + 17 + 25)) \\ = 1.31 \text{ V}$$

At the load end the voltage will double, due to the near unity reflection coefficient, to 2.6 V. It will then increment towards the quiescent 3.0 V in steps separated by one round trip delay (in this case 4.0 ns).



**Figure 9. Single versus Dual Waveforms**

Since this step is well above the threshold region it will not cause any false clock triggering, however designers may be uncomfortable with unwanted reflections on the line. To better match the impedances when driving multiple lines the situation in Figure 10 should be used. In this case the series terminating resistors are reduced such that when the parallel combination is added to the output buffer impedance the line impedance is perfectly matched.



**Figure 10. Optimized Dual Line Termination**

## Power Supply Filtering

The MPC9774 is a mixed analog/digital product. Its analog circuitry is naturally susceptible to random noise, especially if this noise is seen on the power supply pins. Random noise on the  $V_{CC\_PLL}$  power supply impacts the device characteristics, for instance I/O jitter. The MPC9774 provides separate power supplies for the output buffers ( $V_{CC}$ ) and the phase-locked loop ( $V_{CC\_PLL}$ ) of the device. The purpose of this design technique is to isolate the high switching noise digital outputs from the relatively sensitive internal analog phase-locked loop. In a digital system environment where it is more difficult to minimize noise on the power supplies a second level of isolation may be required. The simple but effective form of isolation is a power supply filter on the  $V_{CC\_PLL}$  pin for the MPC9774. Figure 11 illustrates a typical power supply filter scheme. The MPC9774 frequency and phase stability is most susceptible to noise with spectral content in the 100 kHz to 20 MHz range. Therefore, the filter should be designed to target this range. The key parameter that needs to be met in the final filter design is the DC voltage drop across the series filter resistor  $R_F$ . From the data sheet the  $I_{CC\_PLL}$  current (the current sourced through the  $V_{CC\_PLL}$  pin) is typically 5 mA (7.5 mA maximum), assuming that a minimum of 3.02 V ( $V_{CC\_PLL, \text{min}}$ ) must be maintained on the  $V_{CC\_PLL}$  pin. The resistor  $R_F$  shown in Figure 11 must have a resistance of 5–15  $\Omega$  to meet the voltage drop criteria.

The minimum values for  $R_F$  and the filter capacitor  $C_F$  are defined by the required filter characteristics: the RC filter should provide an attenuation greater than 40 dB for noise whose spectral content is above 100 kHz. In the example, RC

filter shown in Figure 11, the filter cut-off frequency is around 3–5 kHz and the noise attenuation at 100 kHz is better than 42 dB.

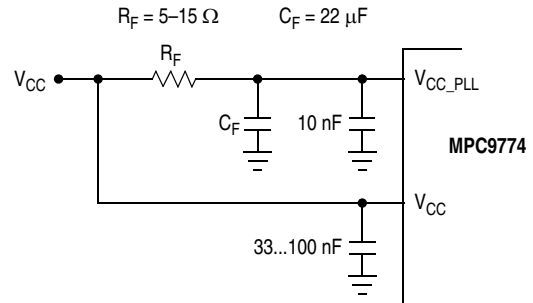


Figure 11.  $V_{CC\_PLL}$  Power Supply Filter

As the noise frequency crosses the series resonant point of an individual capacitor its overall impedance begins to look inductive and thus increases with increasing frequency. The parallel capacitor combination shown ensures that a low impedance path to ground exists for frequencies well above the bandwidth of the PLL. Although the MPC9774 has several design features to minimize the susceptibility to power supply noise (isolated power and grounds and fully differential PLL) there still may be applications in which overall performance is being degraded due to system power supply noise. The power supply filter schemes discussed in this section should be adequate to eliminate power supply noise related problems in most designs.

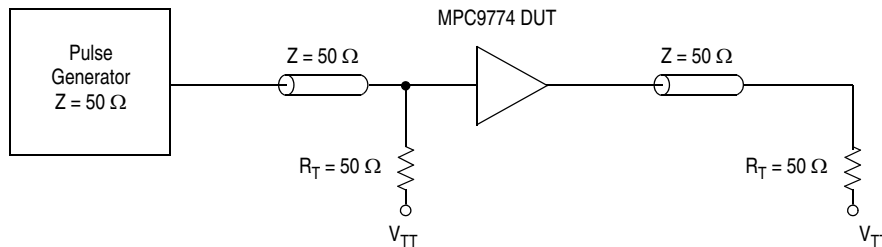
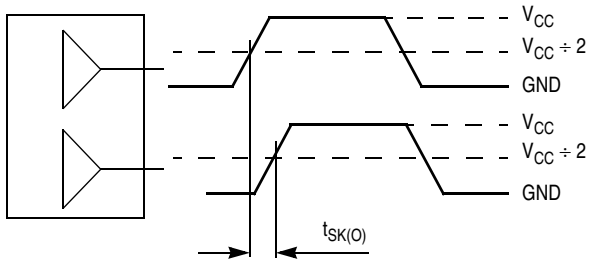
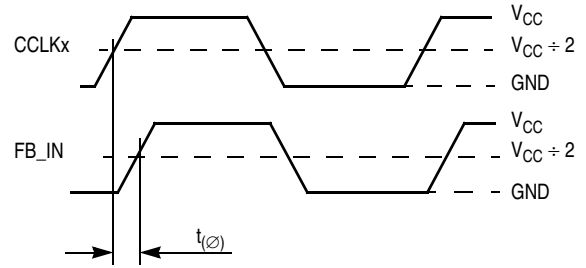


Figure 12. CCLK MPC9774 AC Test Reference

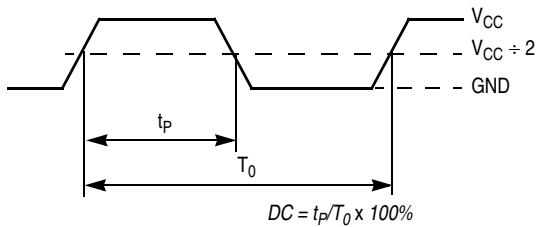


The pin-to-pin skew is defined as the worst case difference in propagation delay between any similar delay path within a single device

**Figure 13. Output-to-Output Skew  $t_{SK(O)}$**

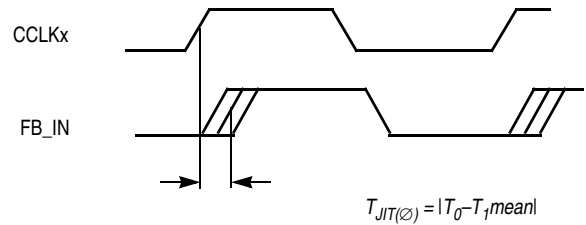


**Figure 14. Propagation Delay ( $t_{(0)}$ , Static Phase Offset) Test Reference**



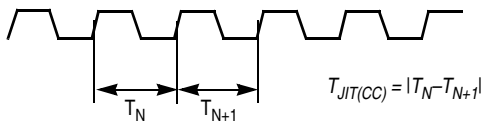
The time from the PLL controlled edge to the non controlled edge, divided by the time between PLL controlled edges, expressed as a percentage

**Figure 15. Output Duty Cycle (DC)**



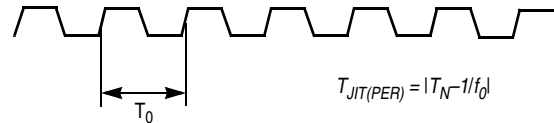
The deviation in  $t_0$  for a controlled edge with respect to a  $t_0$  mean in a random sample of cycles

**Figure 16. I/O Jitter**



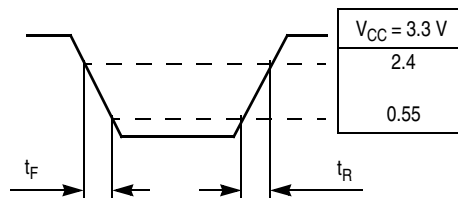
The variation in cycle time of a signal between adjacent cycles, over a random sample of adjacent cycle pairs

**Figure 17. Cycle-to-Cycle Jitter**



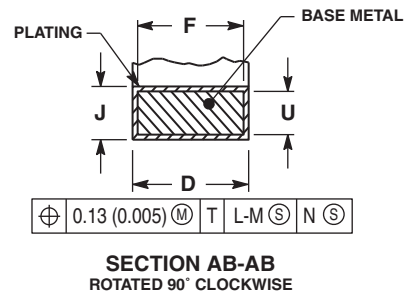
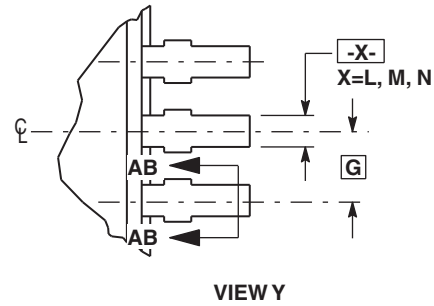
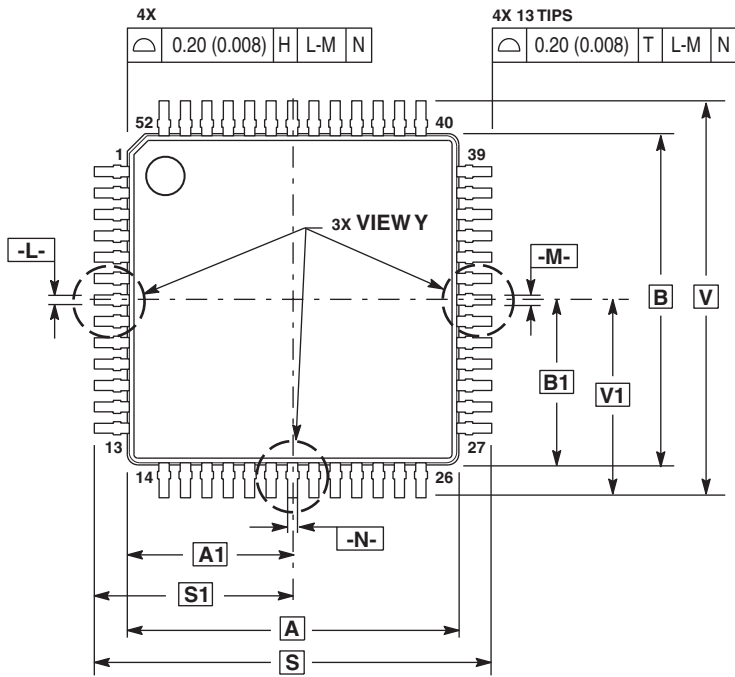
The deviation in cycle time of a signal with respect to the ideal period over a random sample of cycles

**Figure 18. Period Jitter**

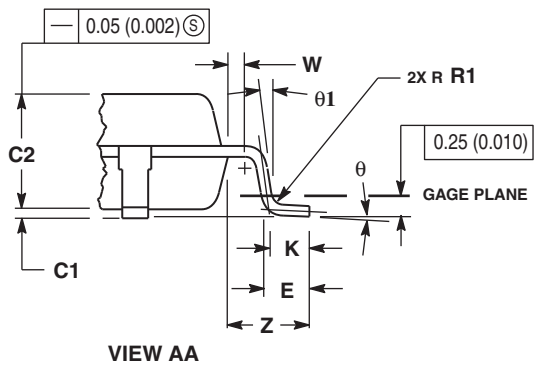
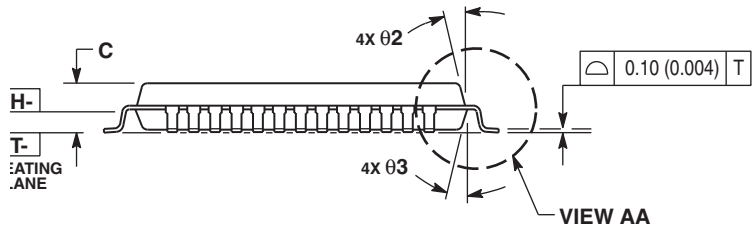


**Figure 19. Output Transition Time Test Reference**

PACKAGE DIMENSIONS



- NOTES:
1. CONTROLLING DIMENSIONS: MILLIMETER.
  2. DIMENSIONING AND TOLERANCING PER ANSI Y14.5M, 1982.
  3. DATUM PLANE -H- IS LOCATED AT BOTTOM OF LEAD AND IS COINCIDENT WITH THE LEAD WHERE THE LEAD EXITS THE PLASTIC BODY AT THE BOTTOM OF THE PARTING LINE.
  4. DATUMS -L-, -M- AND -N- TO BE DETERMINED AT DATUM PLANE -H-.
  5. DIMENSIONS S AND V TO BE DETERMINED AT SEATING PLANE -T-.
  6. DIMENSIONS A AND B DO NOT INCLUDE MOLD PROTRUSION. ALLOWABLE PROTRUSION IS 0.25 (0.010) PER SIDE. DIMENSIONS A AND B DO INCLUDE MOLD MISMATCH AND ARE DETERMINED AT DATUM PLANE -H-.
  7. DIMENSION D DOES NOT INCLUDE DAMBAR PROTRUSION. DAMBAR PROTRUSION SHALL NOT CAUSE THE LEAD WIDTH TO EXCEED 0.46 (0.018). MINIMUM SPACE BETWEEN PROTRUSION AND ADJACENT LEAD OR PROTRUSION 0.07 (0.003).



DIM	MILLIMETERS		INCHES	
	MIN	MAX	MIN	MAX
A	10.00	BSC	0.394	BSC
A1	5.00	BSC	0.197	BSC
B	10.00	BSC	0.394	BSC
B1	5.00	BSC	0.197	BSC
C	---	1.70	---	0.067
C1	0.05	0.20	0.002	0.008
C2	1.30	1.50	0.051	0.059
D	0.20	0.40	0.008	0.016
E	0.45	0.75	0.018	0.030
F	0.22	0.35	0.009	0.014
G	0.65	BSC	0.026	BSC
J	0.07	0.20	0.003	0.008
K	0.50	REF	0.020	REF
R1	0.08	0.20	0.003	0.008
S	12.00	BSC	0.472	BSC
S1	6.00	BSC	0.236	BSC
U	0.09	0.16	0.004	0.006
V	12.00	BSC	0.472	BSC
V1	6.00	BSC	0.236	BSC
W	0.20	REF	0.008	REF
Z	1.00	REF	0.039	REF
$\theta$	0°	7°	0°	7°
$\theta 1$	0°	---	0°	---
$\theta 2$	12°	REF	12°	REF
$\theta 3$	12°	REF	12°	REF

CASE 848D-03  
ISSUE D  
52-LEAD LQFP PACKAGE

## Revision History Sheet

Rev	Table	Page	Description of Change	Date
5		1	NRND – Not Recommend for New Designs	1/8/13
5		1	Removed NRND and removed bullet referencing the replacement part.	5/5/15
5		1	Product Discontinuation Notice - Last time buy expires September 7, 2016. PDN N-16-02	3/16/16

## We've Got Your Timing Solution



6024 Silver Creek Valley Road  
San Jose, California 95138

**Sales**  
800-345-7015 (inside USA)  
+408-284-8200 (outside USA)  
Fax: 408-284-2775  
[www.IDT.com/go/contactIDT](http://www.IDT.com/go/contactIDT)

**Technical Support**  
[clocks@idt.com](mailto:clocks@idt.com)  
+480-763-2056

DISCLAIMER Integrated Device Technology, Inc. (IDT) and its subsidiaries reserve the right to modify the products and/or specifications described herein at any time and at IDT's sole discretion. All information in this document, including descriptions of product features and performance, is subject to change without notice. Performance specifications and the operating parameters of the described products are determined in the independent state and are not guaranteed to perform the same way when installed in customer products. The information contained herein is provided without representation or warranty of any kind, whether express or implied, including, but not limited to, the suitability of IDT's products for any particular purpose, an implied warranty of merchantability, or non-infringement of the intellectual property rights of others. This document is presented only as a guide and does not convey any license under intellectual property rights of IDT or any third parties.

IDT's products are not intended for use in applications involving extreme environmental conditions or in life support systems or similar devices where the failure or malfunction of an IDT product can be reasonably expected to significantly affect the health or safety of users. Anyone using an IDT product in such a manner does so at their own risk, absent an express, written agreement by IDT.

Integrated Device Technology, IDT and the IDT logo are registered trademarks of IDT. Other trademarks and service marks used herein, including protected names, logos and designs, are the property of IDT or their respective third party owners.

Copyright 2016. All rights reserved.