



Chipsmall Limited consists of a professional team with an average of over 10 year of expertise in the distribution of electronic components. Based in Hongkong, we have already established firm and mutual-benefit business relationships with customers from,Europe,America and south Asia,supplying obsolete and hard-to-find components to meet their specific needs.

With the principle of "Quality Parts,Customers Priority,Honest Operation,and Considerate Service",our business mainly focus on the distribution of electronic components. Line cards we deal with include Microchip,ALPS,ROHM,Xilinx,Pulse,ON,Everlight and Freescale. Main products comprise IC,Modules,Potentiometer,IC Socket,Relay,Connector.Our parts cover such applications as commercial,industrial, and automotives areas.

We are looking forward to setting up business relationship with you and hope to provide you with the best service and solution. Let us make a better world for our industry!



## Contact us

Tel: +86-755-8981 8866 Fax: +86-755-8427 6832

Email & Skype: info@chipsmall.com Web: www.chipsmall.com

Address: A1208, Overseas Decoration Building, #122 Zhenhua RD., Futian, Shenzhen, China



Date	SYM	REVISION RECORD	AUTH	DR.	CK.
10/28/06	A	ADDED "ROHS COMPLIANT"	T.B.	B.S.	

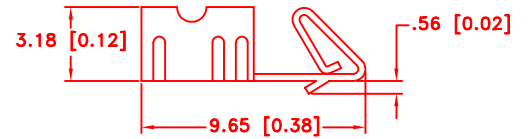
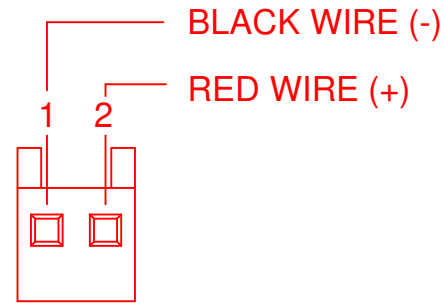
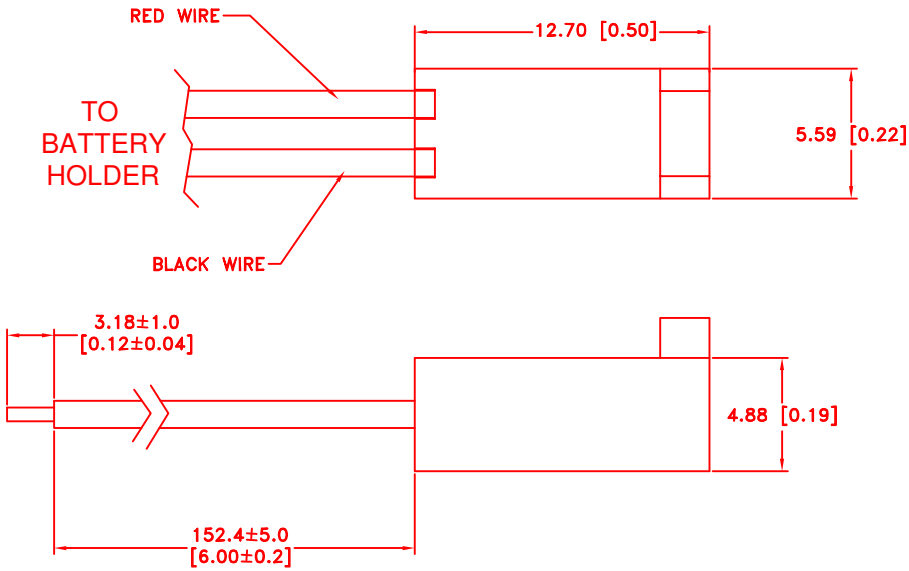

FEMALE CONNECTOR PIN

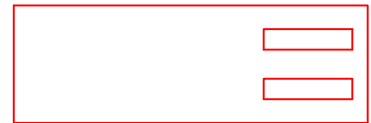

- NOTES:
- HOUSING: RED NYLON, UL94V-0  
TEMP.: -40°C TO 75°C  
UL FILE NO.: E29179, CSA FILE NO.: LR19980  
MATES WITH: 4030, 4380, 4094, 6373, 6410, 7395, 7478, 42152, 42153, 42225, 42226, 42227, 42228, 42375, 42376, 70021, 70327, 70475
  - CONTACT: BRASS, TIN PLATING  
TEMP.: -40°C TO 75°C
  - WIRES : 26 AWG, UL1007, CSA, TR64
  - ROHS COMPLIANT

PART NO.	DESCRIPTION		QTY
22-01-3027	MOLEX TYPE CONNECTOR OR EQUIV.		1
08-50-0114	MOLEX TYPE CONNECTOR PINS OR EQUIV. ( LOOSE FORM)		2
<b>Tolerance</b> (Except as noted)			
 <b>Memory Protection Devices, Inc</b> 200 Broad Hollow Road, Farmingdale, New York 11735			
decimal		Scale	Drawn By B.S.
±.5 (.020)			Approved By T.B.
Fractional	Title		
± .8 (.030)	2 POSITION LATCHING CONNECTOR WITH POLARIZING RIB, 2.54mm PIN SPACING		
Angular	Date	Drawing Number	
± 3°	10/28/06	MPD-411	