



Chipsmall Limited consists of a professional team with an average of over 10 year of expertise in the distribution of electronic components. Based in Hongkong, we have already established firm and mutual-benefit business relationships with customers from,Europe,America and south Asia,supplying obsolete and hard-to-find components to meet their specific needs.

With the principle of “Quality Parts,Customers Priority,Honest Operation,and Considerate Service”,our business mainly focus on the distribution of electronic components. Line cards we deal with include Microchip,ALPS,ROHM,Xilinx,Pulse,ON,Everlight and Freescale. Main products comprise IC,Modules,Potentiometer,IC Socket,Relay,Connector.Our parts cover such applications as commercial,industrial, and automotives areas.

We are looking forward to setting up business relationship with you and hope to provide you with the best service and solution. Let us make a better world for our industry!



Contact us

Tel: +86-755-8981 8866 Fax: +86-755-8427 6832

Email & Skype: info@chipsmall.com Web: www.chipsmall.com

Address: A1208, Overseas Decoration Building, #122 Zhenhua RD., Futian, Shenzhen, China



DC-DC Converter Specification(DRAFT)

MPDTH12010YA*

1. Application

This specification applies to DC-DC Converter for telecommunication / data-communication equipment, MPDTH12010YAS/YAH. For any other application, please contact us before using this product.

2. Customer Reference

Customer Spec. Number
Customer Part Number

3. Murata Part Number

MPDTH12010YAS / MPDTH12010YAH

4. Appearance, Dimensions

[YAS]

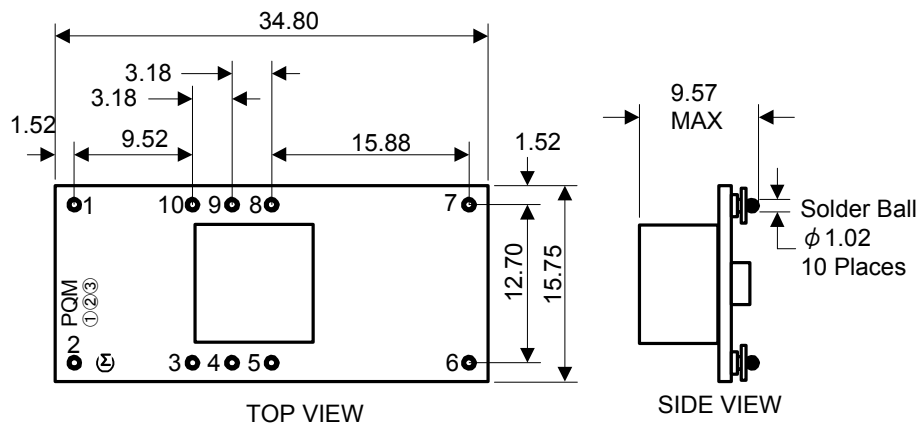

[YAH]

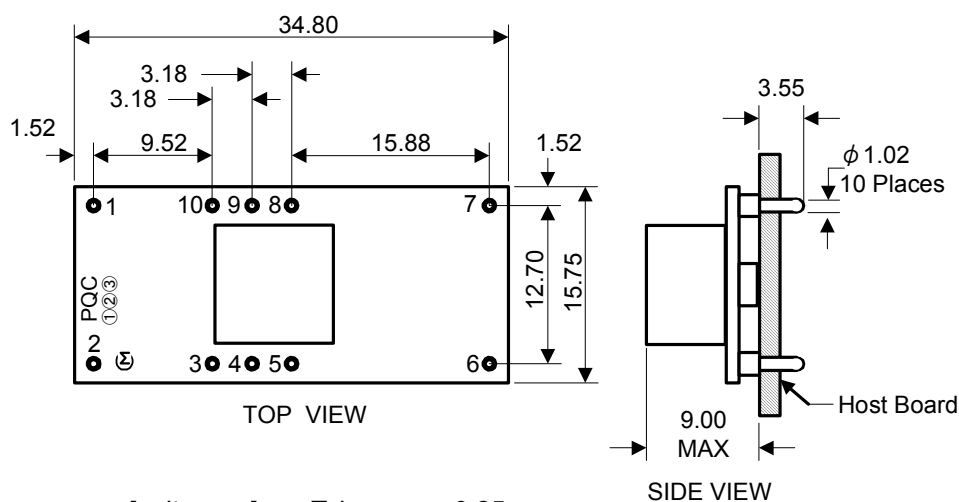

[unit : mm] Tolerance : 0.25mm

⚠ Note:

1. This datasheet is downloaded from the website of Murata Manufacturing co., ltd. Therefore, it's specifications are subject to change or our products in it may be discontinued without advance notice. Please check with our sales representatives or product engineers before ordering.
2. This datasheet has only typical specifications because there is no space for detailed specifications. Therefore, please approve our product specifications or transact the approval sheet for product specifications before ordering.

Marking

- (1) MFG ID 
 (2) Parts No. YAS → PQM
 YAH → PQC
 (3) Lot No. ①②③
 ① Production factory Mark
 ② Production Year
 ③ Production Month (1,2,3,⋯9,O,N,D)

5. Pin Number and Function

Pin No.	Symbol	Function
1	GND	GND
2	Vin	Input
3	Inhibit	Remote ON/OFF
4	No Connect	
5	VoSense	Vout sense
6	VTT	VTT Output
7	GND	GND
8	Vref	Reference Voltage input
9	No Connect	
10	No Connect	

6. Block Diagram

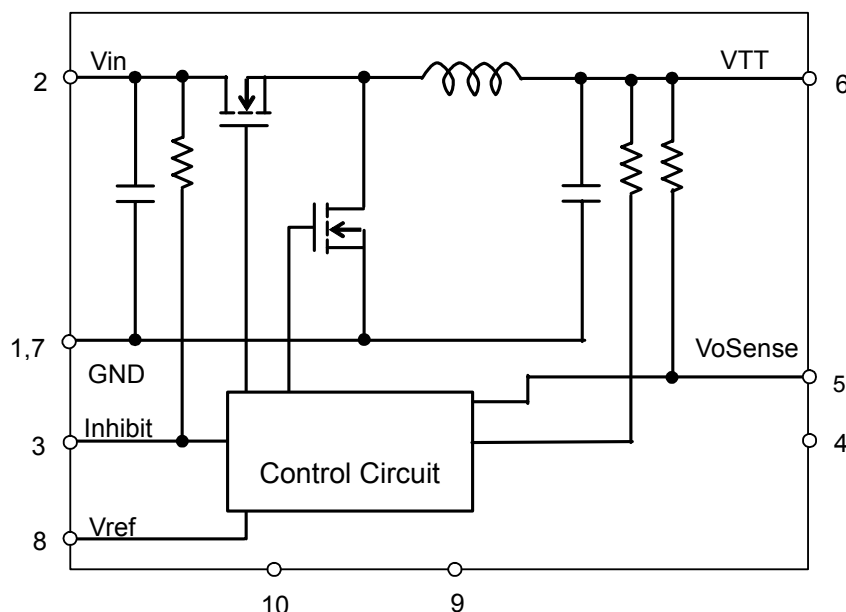

7. Ambient Condition

- 7.1 Operating Temperature Range -40 to +85 °C
 7.2 Storage Temperature Range -40 to +125 °C

8. Absolute Rating

- 8.1 Vref Pin Input Voltage Range -0.3V to (Vin + 0.3V)

⚠ Note:

- This datasheet is downloaded from the website of Murata Manufacturing co., Ltd. Therefore, it's specifications are subject to change or our products in it may be discontinued without advance notice. Please check with our sales representatives or product engineers before ordering.
- This datasheet has only typical specifications because there is no space for detailed specifications. Therefore, please approve our product specifications or transact the approval sheet for product specifications before ordering.

9. Characteristics

9.1 Electrical Characteristics (Ta=25°C)

Unless otherwise stated,

Ta=25°C, Vin=12V, Vref=1.25V, Cin=560μF, Co1=940μF, Co2=400μF, Io=Iomax

Item	Symbol	Condition	Value			Unit	
			Min.	Typ.	Max.		
Output Current	Io	Over ΔVref Range	0	-	±12(*1)	A	
Input Voltage Range	Vin	Over Io Range	10.8	12	13.2	V	
Tracking Range for Vref	ΔVref		0.55	-	1.8	V	
Tracking Tolerance to Vref	VTT -Vref	Io=0A	-	-	±10	mV	
Load Regulation	ΔRegload	Over Io Range	-	±10	-	mV	
Efficiency	η	Io=10A	-	85	-	%	
Ripple Voltage	Vr	BW=20MHz,	-	20	-	mVpp	
Short Circuit Protection	Io trip	Reset, Followed by Auto-Recovery	-	20	-	A	
Transient Response	ttr	15A/μs load step, from -1.5A to +1.5A	Recovery Time	-	30	-	μsec
	ΔVtr		Vo Deviation	-	30	40	mV
Rising UVLO Threshold	UVLOr	Vin Increasing	-	9.5	10.4	V	
Falling UVLO Threshold	UVLOf	Vin Decreasing	8.1	9.0	-	V	
Input High Voltage	VIH		This pin should left open to operate (*3)				
Input Low Voltage	VIL		-0.2	-	0.6	V	
Input Low Current	IIL inhibit		-	130	-	μA	
Input Standby Current	Iin inh	Inhibit to GND	-	10	-	mA	
Operating Frequency	Frq		-	250	-	kHz	
External Input Capacitor	Cin		560 (*4)	-	-	μF	
External Output Capacitor	Cout	Non-Ceramic (ESR ≥ 4mΩ)	940 (*5)	-	6600	μF	
		Ceramic	0	400 (*5)	600	μF	
MTBF	MTBF	Per Bellcore TR-332, 50% stress, Ta=40°C, Ground Benign	6	-	-	10 ⁶ Hrs	

⚠ Note:

1. This datasheet is downloaded from the website of Murata Manufacturing co., Ltd. Therefore, it's specifications are subject to change or our products in it may be discontinued without advance notice. Please check with our sales representatives or product engineers before ordering.
2. This datasheet has only typical specifications because there is no space for detailed specifications. Therefore, please approve our product specifications or transact the approval sheet for product specifications before ordering.

- (*1) Rating is conditional on the module being directly soldered to a 4-layer PCB with 1 oz. copper.
- (*2) Up to 10 ms pulse period at 10 % maximum duty.
- (*3) This control pin has an internal pull-up. If it is left open-circuit the module will operate when input power is applied.
- (*4) The external input capacitor must be rated at or above 500mA rms of ripple current.
- (*5) The typical value of external output capacitance value ensures that VTT meets the specified transient performance requirements for the memory bus.



Caution

The above electrical characteristics are guaranteed in the condition that the impedance of the input voltage source is sufficiently low as shown in clause 10. Connecting an input inductance or using an input power supply with output inductance may cause an unstable operation of this product. Please check the proper operation of this product with the peripheral circuits on your product.

9.2 Safe Operating Area (SOA)

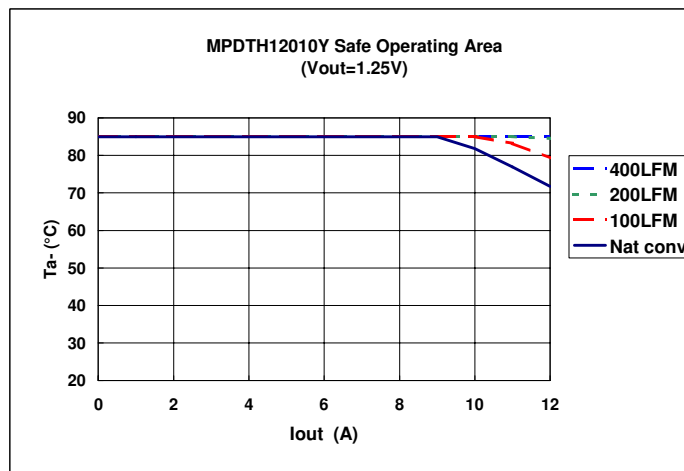

The above SOA represents the condition at which internal components are at or below the manufacturer's maximum operating temperatures. Derating limits apply to modules soldered directly to 4 in.×4in. 4 layer PCB with 1 oz. copper. For more reliable operation, appropriate derating is desirable.

⚠ Note:

1. This datasheet is downloaded from the website of Murata Manufacturing co., Ltd. Therefore, it's specifications are subject to change or our products in it may be discontinued without advance notice. Please check with our sales representatives or product engineers before ordering.
2. This datasheet has only typical specifications because there is no space for detailed specifications. Therefore, please approve our product specifications or transact the approval sheet for product specifications before ordering.

9.3 Power Supply On/OFF Sequence

(1) Start-up by Vin input (Inhibit pin is left open)

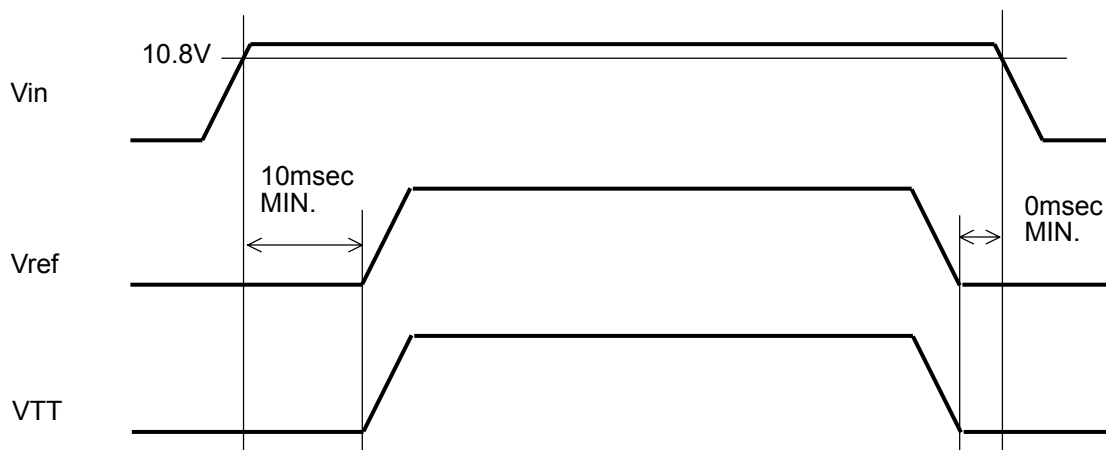

(2) Start-up using Inhibit pin

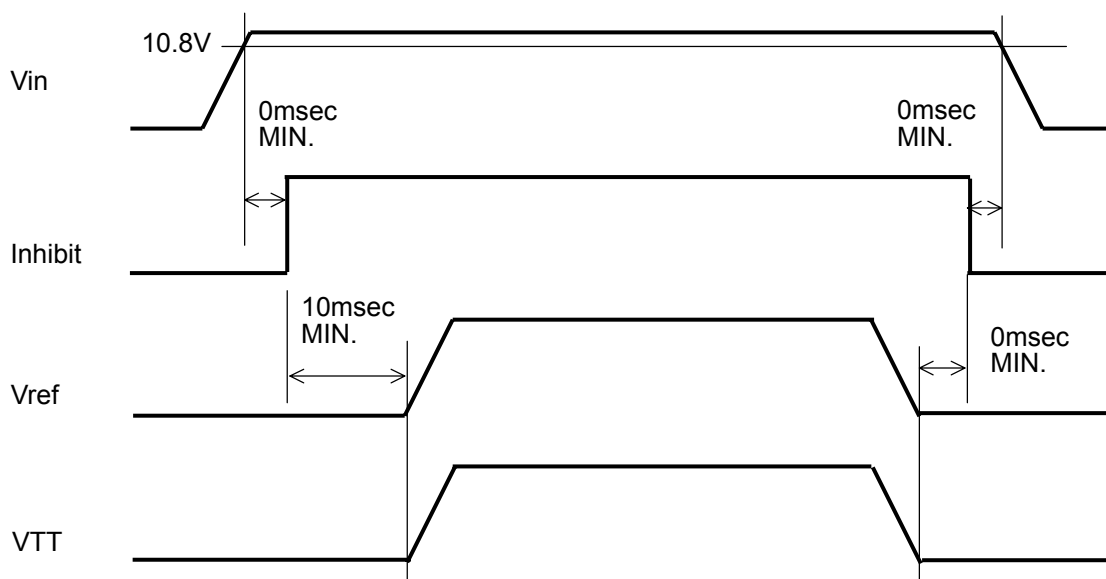

Note:

1. This datasheet is downloaded from the website of Murata Manufacturing co., Ltd. Therefore, it's specifications are subject to change or our products in it may be discontinued without advance notice. Please check with our sales representatives or product engineers before ordering.
2. This datasheet has only typical specifications because there is no space for detailed specifications. Therefore, please approve our product specifications or transact the approval sheet for product specifications before ordering.

10. Test Circuit

In the following test circuit, the initial values under item 9 should be met.

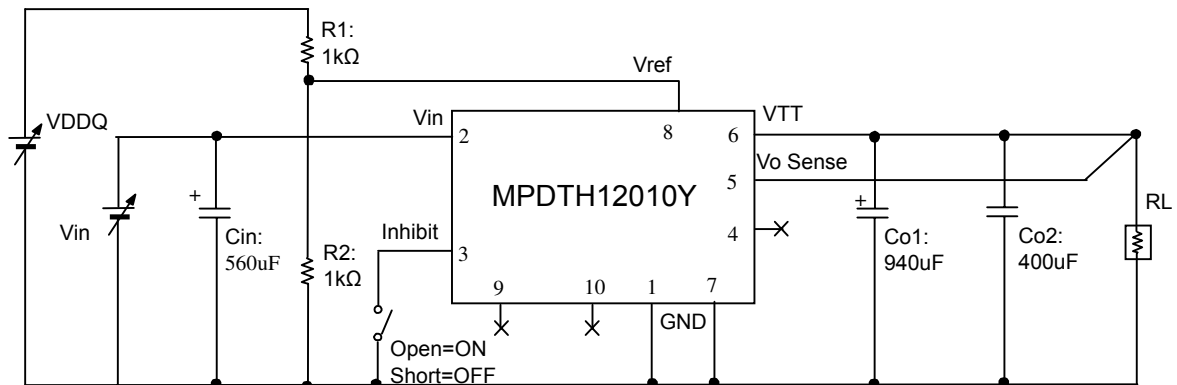

Cin	:	560µF / 25V	(Low-ESR Electrolytic Capacitor)
Co1	:	940µF / 10V	(Low-ESR Electrolytic Capacitor)
Co2	:	400µF / 6.3V	(Ceramic Capacitor)

Ripple Noise Measurement Circuit

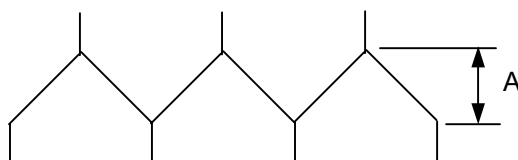
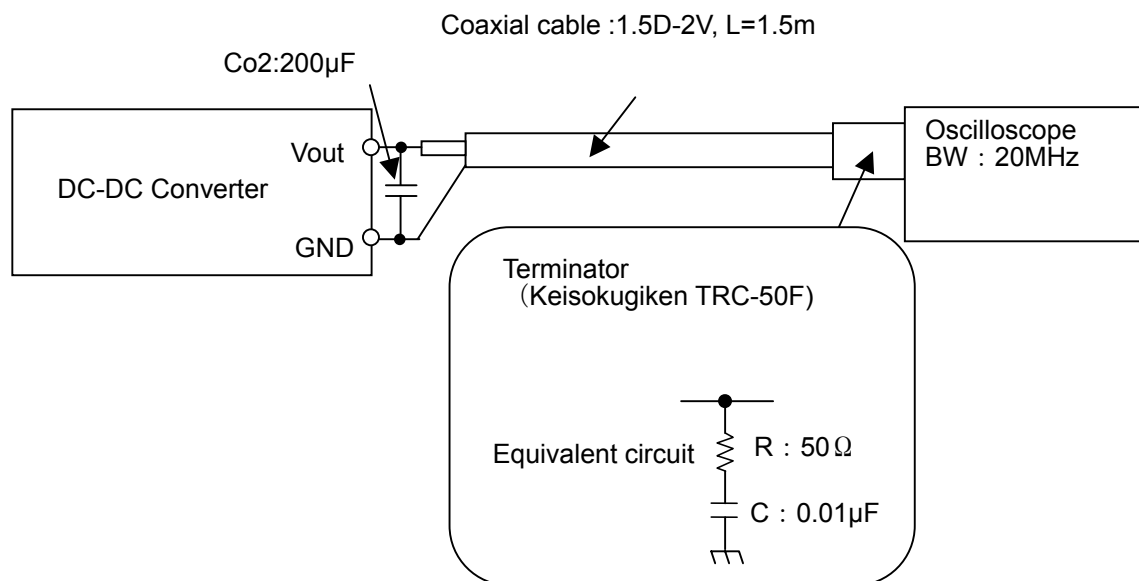

A : Output Ripple Voltage

⚠ Note:

1. This datasheet is downloaded from the website of Murata Manufacturing co., Ltd. Therefore, it's specifications are subject to change or our products in it may be discontinued without advance notice. Please check with our sales representatives or product engineers before ordering.
2. This datasheet has only typical specifications because there is no space for detailed specifications. Therefore, please approve our product specifications or transact the approval sheet for product specifications before ordering.

11 . Packaging Information

11. 1 Tray Dimensions

DC-DC Converter devices are placed on the trays. (See Fig.1)

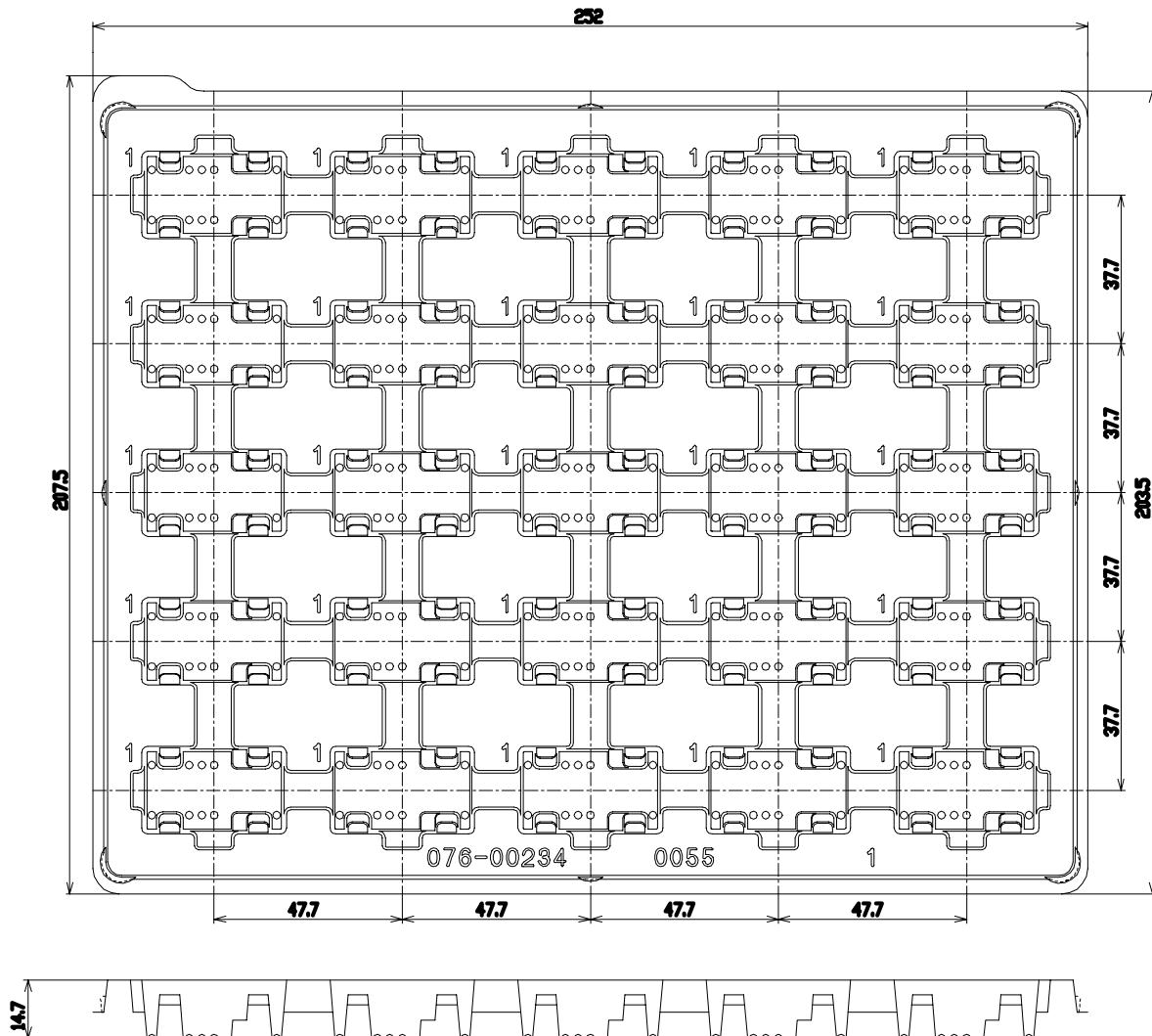

Fig.1

11. 2 Maximum Pieces per a Tray

25 pcs/ tray

(except when less than 25)

⚠ Note:

1. This datasheet is downloaded from the website of Murata Manufacturing co., Ltd. Therefore, it's specifications are subject to change or our products in it may be discontinued without advance notice. Please check with our sales representatives or product engineers before ordering.
2. This datasheet has only typical specifications because there is no space for detailed specifications. Therefore, please approve our product specifications or transact the approval sheet for product specifications before ordering.

11.3 Packaging Form

Trays with products are lidded and packed in a corrugated box. (See Fig.2)

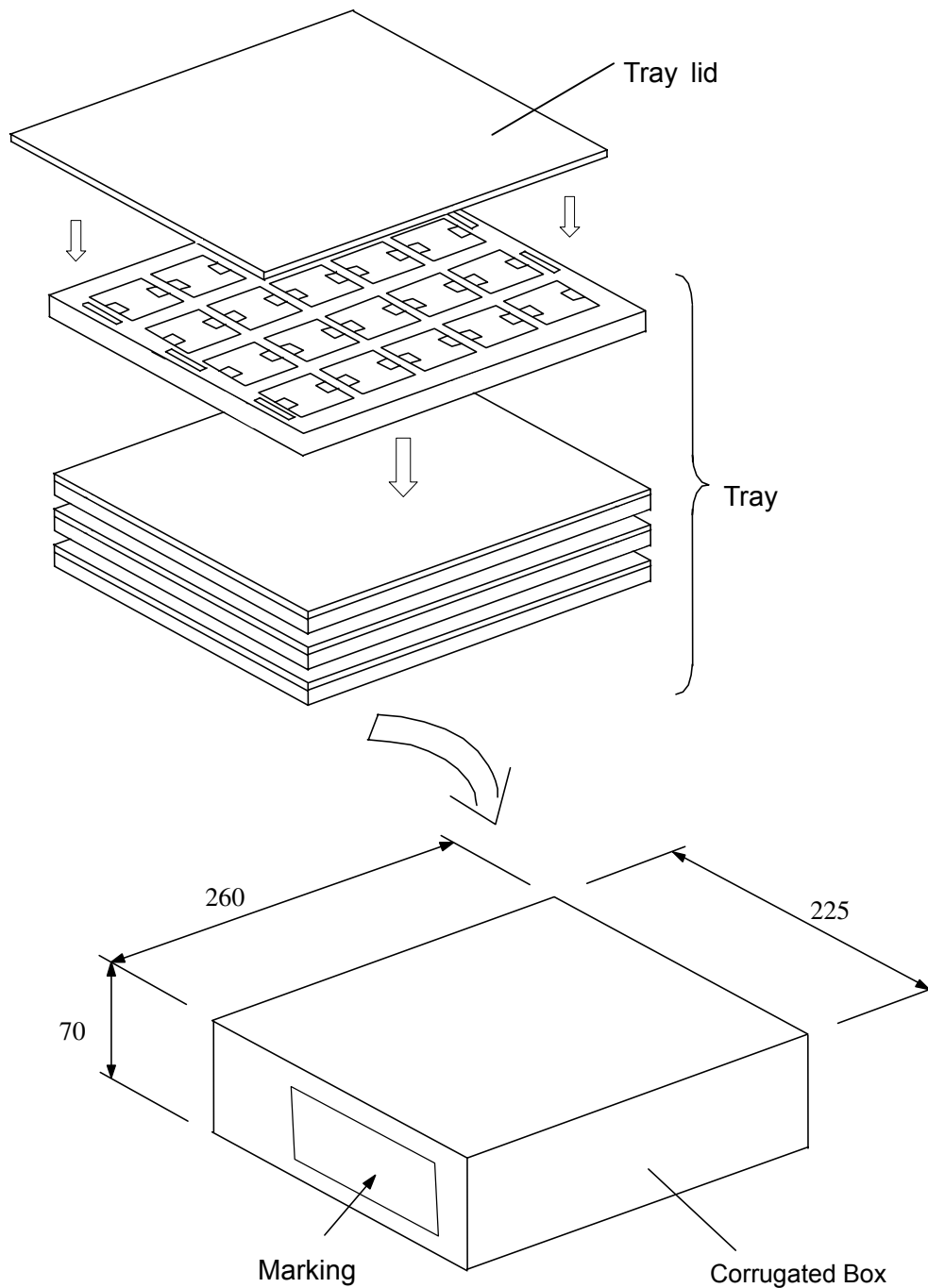

※Marking on the box
 MURATA Parts Number
 Quantity
 Inspection No.

Fig.2

⚠ **Note:**

1. This datasheet is downloaded from the website of Murata Manufacturing co., Ltd. Therefore, it's specifications are subject to change or our products in it may be discontinued without advance notice. Please check with our sales representatives or product engineers before ordering.
2. This datasheet has only typical specifications because there is no space for detailed specifications. Therefore, please approve our product specifications or transact the approval sheet for product specifications before ordering.

12. Production factory
 Komatsu Murata Mfg.Co.,Ltd.
 Kanazu Murata Mfg.Co.,Ltd.
 Wakura Murata Mfg.Co.,Ltd.

13.  Caution

1. Be sure to provide an appropriate fail-safe function on your product to prevent secondary damage that may be caused by the functional trouble or the failure of this product.
2. This product has no inrush protection circuit. If any inrush current is applied to this product (ex. using mechanical switch), it may be damaged by surge voltage.
3. Please connect the input terminal with the correct polarity. If connected incorrectly, this product may be damaged. If this product is damaged internally, an elevated input current may flow, and an abnormal temperature rise of this product or the damage of your product may be caused. Please add a diode and fuse per the following diagram to prevent these problems.

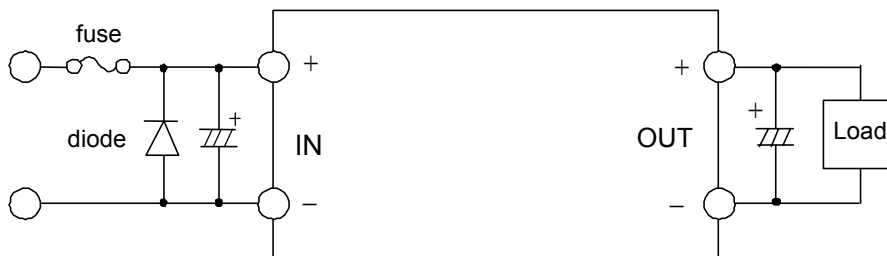

※Please select a diode/ fuse combination after confirming the operation of your product.

4. Limitation of Application

Please contact us before using this product for the applications listed below which require especially high reliability for the prevention of defects, which might directly cause damage to the third party's life, body or property.

- ①Aircraft equipment
- ②Aerospace equipment
- ③Undersea equipment
- ④Power plant control equipment
- ⑤Medical equipment
- ⑥Transportation equipment (vehicles, trains, ships, etc.)
- ⑦Traffic signal equipment
- ⑧Disaster prevention /crime prevention equipment
- ⑨Any other application of similar complexity and/or reliability requirements to the applications listed above.

14. Notice

14. 1 Soldering

14. 1. 1 Flux

Please solder this product with Rosin Flux which contains of 0.2wt%. or less chlorine.
 Please do not use high activity acid flux or water soluble flux because they may erode metal or glass portion of this product and may cause defectiveness or deterioration of this product.

 Note:

1. This datasheet is downloaded from the website of Murata Manufacturing co., Ltd. Therefore, it's specifications are subject to change or our products in it may be discontinued without advance notice. Please check with our sales representatives or product engineers before ordering.
2. This datasheet has only typical specifications because there is no space for detailed specifications. Therefore, please approve our product specifications or transact the approval sheet for product specifications before ordering.

14. 1. 2 Recommended PCB Land Pattern

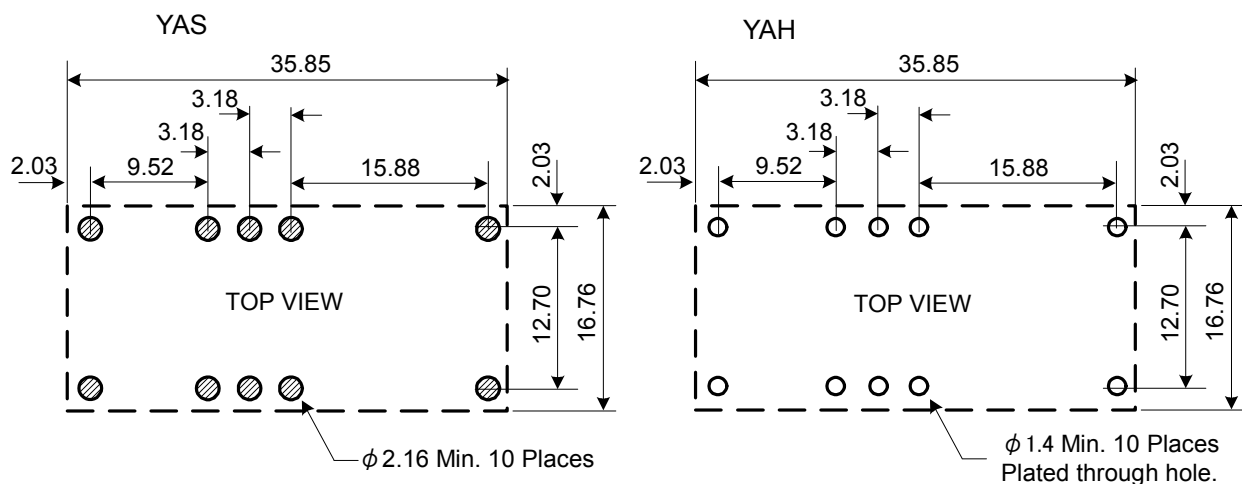

14. 1. 3 Recommended Soldering Conditions

This product is RoHS compatible. The following profile is recommended for the reflow of the SMD product (YAS) using Pb-free solder paste (Sn-Ag-Cu).

Method : Full convection reflow soldering

Reflow Soldering Profile
 JEDEC IPC/JEDEC J-STD-020C
 Table 5-2 Classification Reflow Profile
 Pb-Free Assembly Large Body

Profile details

Soldering temperature	: 245°C +0/-5°C
Soldering time	: 20 to 40 seconds, 240 to 245°C
Heating time	: 60 to 150 seconds, over 217°C
Preheating time	: 60 to 180 seconds, 150 to 200°C
Programming rate	: 3°C / sec. Max., 217 to 245°C
Descending rate	: 6°C / sec. Max.
Total soldering time	: 8 minutes Max., 25 to 245°C
Times	: 1time

- ※ Do not add vibration to this product during reflow.
 Please carefully regulate temperature control as mounted parts may come off from this product if left under the high temperature for an extended time.

14. 2 Cleaning

Please use no-clean type flux and do not wash this product.

⚠ Note:

1. This datasheet is downloaded from the website of Murata Manufacturing co., Ltd. Therefore, it's specifications are subject to change or our products in it may be discontinued without advance notice. Please check with our sales representatives or product engineers before ordering.
2. This datasheet has only typical specifications because there is no space for detailed specifications. Therefore, please approve our product specifications or transact the approval sheet for product specifications before ordering.

14. 3 Storage

14. 3. 1 This product should be treated as MSL2 product when it is reflowed according to the recommended soldering condition, which is described at 14.1.3. .

At below 30°C 60%R.H., this product can be stored 1 year without baking.

If stored over 1 year, please bake this product before soldering.

The recommendable baking condition is at 125±5°C /24hour.

If baked in a tray of in a tape, 60±5°C /168hour is recommended.

Please avoid damp and heat or such places where the temperature greatly changes, as water may condense on this product, and the quality of characteristics may be reduced, and/or be the solderability may be degraded.

If this product needs to be stored for a long time (more than 1 year), this product may be degraded in solderability and/or corroded. Please test the solderability of this product regularly.

14. 3. 2 Please do not store this product in the conditons such as :

a dusty place, a place exposed directly to sea breeze, or in an atmosphere containing corrosive gas (Cl₂,NH₃,SO₂,NOX and so on).

14. 4 Operational Environment and Operational Conditions

14. 4. 1 Operational Environment

This product is not water-, chemical- or corrosion-proof.

In order to prevent leakage of electricity and abnormal temperature rise of this product, do not use this product in the following conditions:

- (1) in an atmosphere containing corrosive gas (Cl₂, NH₃, SO₂, NOX and so on)
- (2) in a dusty place
- (3) in a place exposed to direct sunlight
- (4) in such a place where water splashes or in such a humid place where water condenses
- (5) in a place exposed to sea breeze
- (6) in any other places similar to the above

14. 4. 2 Operational Conditions

Please use this product within specified values (power supply, temperature, input, output and load condition, and so on). As the input voltage may drop due to line impedance, please make sure that the input voltage is within the specified values.

If not used within the specified values, defectiveness and deterioration of this product may be caused. Even if this product can endure the condition for short time, it may cause degradation of reliability.

14. 4. 3 Note prior to use

Defectiveness and reliability degradation may be caused if high static electricity, over rated voltage or reverse voltage are applied to this product. Please be sure to avoid the followings:

- (1) over rating power supply, reverse power supply or inadequate connection of 0 V(DC)line
- (2) electrostatic discharge from production line and/or operator
- (3) electrified product from electrostatic induction

Please avoid an excessive mechanical shock.

If this product is dropped on the floor, etc., a crack to the core of inductors and monolithic ceramic capacitors may occur.

Please handle with care to avoid a strong shock to this product.

14. 5 Transportation

When transporting this product, please pack it in order to avoid damage by mechanical vibration or echanical shock, and please give instructions and set guidelines to the carriers to prevent rough handling.

When transporting this product overseas (in particular, by sea), bad environment of transportation may be expected, therefore please pack this product considering mechanical strength, vibration-resistance and humidity-resistance.

The packaging designed for domestic sales may not suitable for overseas transportation.

Please contact us if this product with domestic packing is transported overseas.

15. Note

1. Please make sure that the evaluation and testing are completed with this product actually assembled on your product.
2. All the items and parameters in this product specification have been prescribed on the premise that our product is used for the purpose, under the condition and in the environment mutually agreed upon . Please do not use this product deviating from such agreement.

Note:

1. This datasheet is downloaded from the website of Murata Manufacturing co., ltd. Therefore, it' s specifications are subject to change or our products in it may be discontinued without advance notice. Please check with our sales representatives or product engineers before ordering.
2. This datasheet has only typical specifications because there is no space for detailed specifications. Therefore, please approve our product specifications or transact the approval sheet for product specifications before ordering.