



Chipsmall Limited consists of a professional team with an average of over 10 year of expertise in the distribution of electronic components. Based in Hongkong, we have already established firm and mutual-benefit business relationships with customers from,Europe,America and south Asia,supplying obsolete and hard-to-find components to meet their specific needs.

With the principle of “Quality Parts,Customers Priority,Honest Operation,and Considerate Service”,our business mainly focus on the distribution of electronic components. Line cards we deal with include Microchip,ALPS,ROHM,Xilinx,Pulse,ON,Everlight and Freescale. Main products comprise IC,Modules,Potentiometer,IC Socket,Relay,Connector.Our parts cover such applications as commercial,industrial, and automotives areas.

We are looking forward to setting up business relationship with you and hope to provide you with the best service and solution. Let us make a better world for our industry!



Contact us

Tel: +86-755-8981 8866 Fax: +86-755-8427 6832

Email & Skype: info@chipsmall.com Web: www.chipsmall.com

Address: A1208, Overseas Decoration Building, #122 Zhenhua RD., Futian, Shenzhen, China



MPU-32 SERIES (PGR-6200)

Motor Protection Unit



Description

The MPU-32 Motor Protection Unit is used to provide current- and temperature-based protection, metering, and data logging for three-phase low-voltage medium-horsepower induction motors. This relay is ideal for retrofitting and upgrading obsolete or aging motor protection using existing CTs. See the PMA Family of Panel Mount Adapter Kits to replace common obsolete relays.

1 Motor Protection Unit

- Three ac-current inputs
- Earth-leakage-CT input
- Programmable digital input
- 24-Vdc source for digital input
- Programmable 4-20-mA analog output
- On-board temperature-sensor input,
- 100-Ω-Platinum RTD or PTC
- Three programmable output relays
- Local RS-232 communications, optional Network Communications
- PC-interface software (SE-Comm-RIS)
- 4 line x 20 character backlit LCD display
- Keypad for programming and display selection
- 4 LEDs; 1 user programmable

Simplified Circuit Diagram

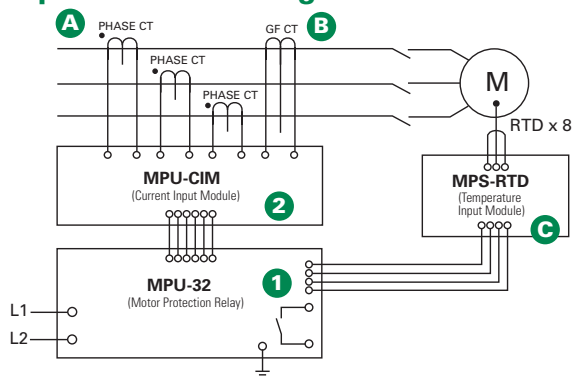

2 Current Input Module (MPU-CIM)

The MPU-CIM Current Input Module is the interface between the MPU-32 relay and the 5-A-secondary, 1-A-secondary, and sensitive current transformers. The MPU-CIM is ordered separately from the MPU-32 and can be surface- or DIN-rail mounted. Wire-clamping terminals are standard but the MPU-CTI is available for those who require ring-tongue terminals.

Accessories

A Phase Current Transformers
Phase CTs are required to detect phase currents. For upgrade applications, existing CTs can be used.

B Ground-Fault Current Transformer
Optional zero-sequence current transformer detects ground-fault current. Available with 5-A and 30-A primary ratings for low-level pickup.

C MPS-RTD Temperature Input Module
Optional module provides 8 inputs to connect Pt100, Ni100, Ni120, and Cu10 RTDs.

D MPS-DIF Differential Current Module
Optional motor differential protection, compatible with core balance and summation current transformer connections.

Ordering Information

ORDERING NUMBER	COMMUNICATION
MPU-32-00-00	TIA-232
MPU-32-01-00	TIA-232 & TIA-485
MPU-32-02-00	TIA-232 & DeviceNet™
MPU-32-04-00	TIA-232 & EtherNet/IP™ & Modbus® TCP

NOTE: One of the following is required: MPU-CIM-00-00 Current Input Module, or MPU-CTI-RT-00 Current Input Module with ring-tongue terminals.

ACCESSORIES	REQUIREMENT
Phase CTs	Required
MPS-RTD-01-00	Optional
MPS-DIF-01-00	Optional
MPU-32-SMK	Optional
CA-945	Optional
MPU-16A-Y92A-96N	Optional

MPU-32 SERIES (PGR-6200)

Motor Protection Unit

Features & Benefits

FEATURES	IEEE #	BENEFITS
Overload	49, 51	Extends motor life and prevents insulation failures and fires
Dynamic thermal model		Provides protection through starting, running, and cooling cycles
Communications		Remotely view measured values and event records, reset trips, and access setpoints
Ground fault	50G/N, 51G/N	Prevents catastrophic failures and fires
Current unbalance/ Phase loss/Phase reverse	46	Prevents overheating due to unbalanced phases
RTD temperature	38, 49	RTD temperature protection (MPS-RTD module) for high-ambient or loss-of-ventilation protection
Phase loss/Phase reverse (current)	46	Detects unhealthy supply conditions
Overcurrent	50, 51	Prevents catastrophic failures and fires; extends motor life
Jam		Prevents motor damage by detecting mechanical jams or excessive loading
Undercurrent	37	Detects low level or no-load conditions
PTC overtemperature	49	Overtemperature (PTC) protection for high-ambient or loss-of-ventilation detection
Starts per hour	66	Limits the motor starts per hour to prevent overheating
Differential	87	Optional MPS-DIF module for sensitive winding-fault protection
Reduced overcurrent mode		Minimizes arc-flash hazards during maintenance
Metering		View measured and calculated parameters with on-board display
MPU-CIM		Separate current input module to reduce risk of open-CT hazard and for convenient installation
Analog output		Provides means for metering selectable parameters
Data logging		On-board 100-event recorder for data logging
Conformal coating		Internal circuits are conformally coated to protect against corrosion and moisture

Wiring Diagram

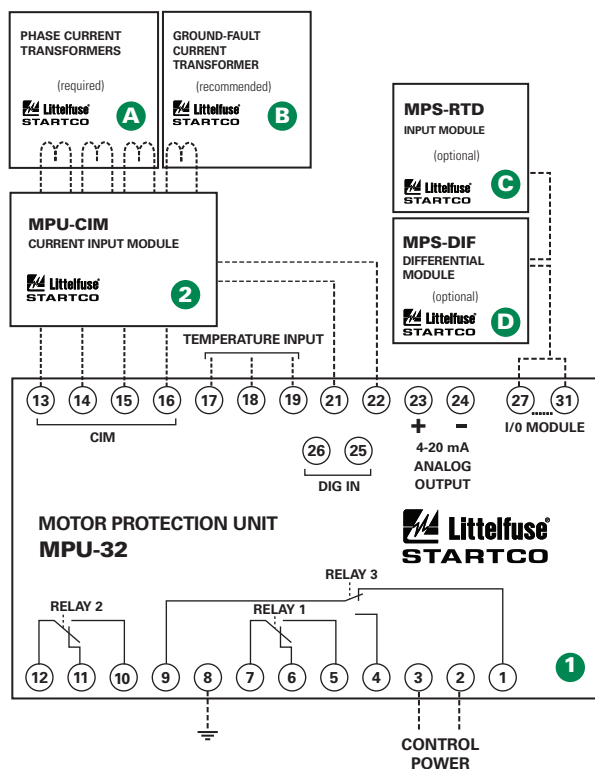

Specifications

Protective Functions (IEEE Device Numbers)	Overload (49, 51) Phase reverse (current) (46) Overcurrent (50, 51) Jam Ground fault (50G/N, 51G/N) PTC overtemperature (49)	RTD temperature (38, 49) Unbalance (current) (46) Starts per hour (66) Differential (87) Phase loss (current) (46) Undercurrent (37)
Input Voltage	65-265 Vac, 25 VA; 80-275 Vdc, 25 W	
Power-Up Time	800 ms at 120 Vac	
Ride-Through Time	100 ms minimum	
24-Vdc Source	100 mA maximum	
AC Measurements	True RMS and DFT, Peak, 16 samples/cycle, and positive and negative sequence of fundamental 50, 60 Hz or ASD	
Frequency	50, 60 Hz or ASD	
Output Contacts	Three Form C programmables	
Communications	TIA-232 (standard); TIA-485, DeviceNet™, Ethernet (optional)	
Analog Output	4-20 mA, programmable	
Conformally Coated	Standard feature	
Warranty	10 years	
Mounting (Control Unit)	Panel (standard) Surface (with MPU-32-SMK converter kit)	
(Current Input Module)	DIN, Surface	
Approvals	CSA certified, CE (European Union), UL Recognized, C-Tick (Australian)	