



Chipsmall Limited consists of a professional team with an average of over 10 year of expertise in the distribution of electronic components. Based in Hongkong, we have already established firm and mutual-benefit business relationships with customers from,Europe,America and south Asia,supplying obsolete and hard-to-find components to meet their specific needs.

With the principle of “Quality Parts,Customers Priority,Honest Operation,and Considerate Service”,our business mainly focus on the distribution of electronic components. Line cards we deal with include Microchip,ALPS,ROHM,Xilinx,Pulse,ON,Everlight and Freescale. Main products comprise IC,Modules,Potentiometer,IC Socket,Relay,Connector.Our parts cover such applications as commercial,industrial, and automotives areas.

We are looking forward to setting up business relationship with you and hope to provide you with the best service and solution. Let us make a better world for our industry!



Contact us

Tel: +86-755-8981 8866 Fax: +86-755-8427 6832

Email & Skype: info@chipsmall.com Web: www.chipsmall.com

Address: A1208, Overseas Decoration Building, #122 Zhenhua RD., Futian, Shenzhen, China





MPU-6000/MPU-6050 9-Axis Evaluation Board User Guide



Table of Contents

1. REVISION HISTORY	3
2. PURPOSE	4
2.1 USAGE	4
2.2 RELATED DOCUMENTS	4
3. MPU-6000 9-AXIS EV BOARD OVERVIEW	4
3.1 MPU-6000 KEY FUNCTION AND PIN-OUTS	5
3.2 MPU-6000 vs. MPU-6050	5
3.3 MPU-6000 BUS CONNECTION	5
4. SCHEMATIC	7
5. BILL OF MATERIALS	8
6. POWER SUPPLY CONNECTIONS	8
7. MPU-6000 EVB CONNECTOR SIGNALS DESCRIPTION	9
7.1 CONNECTING THE FSYNC LINE	11
7.2 SERIAL BUS LEVELS, SPEEDS AND TERMINATIONS	11
8. DATA GATHERING OPTIONS	11
8.1 CONNECTION TO ARM EVB	11
8.2 USE OF MPU-6000 WITHOUT ARM EVB BOARD	12
9. SPECIAL INSTRUCTIONS	12
9.1 ELECTROSTATIC DISCHARGE SENSITIVITY	12
9.2 BOARD LAYOUT	12



1. Revision History

Date	Revision	Description
1/12/2011	01	Initial release



2. Purpose

This document describes the hardware and circuitry on the MPU-6000 and MPU-6050 (collectively called the MPU-60X0) 9-Axis Evaluation (EV) Board. This EVB is used for evaluating the MPU-6000 and MPU-6050. It covers applying the EV board to a larger system, understanding key signals and circuit functions, hardware jumper settings, and port connectors.

2.1 Usage

This evaluation board provides nine axes of motion sensing, comprised of:

- Digital-output X-, Y-, and Z-Axis angular rate sensors (gyroscopes) with a user-programmable full-scale range of ± 250 , ± 500 , ± 1000 , and $\pm 2000^\circ/\text{sec}$
- Digital-output tri-axis accelerometer with a programmable full scale range of $\pm 2g$, $\pm 4g$, $\pm 8g$ and $\pm 16g$
- Digital-output tri-axis compass with a full scale range of $\pm 1200\mu\text{T}$
- Data is measured using on-chip ADCs and is transmitted over I²C or SPI interfaces.

The Evaluation board may be used by itself using SPI or I²C serial communications interfaces. Alternatively, it may be connected to InvenSense's ARM Evaluation Board (INVARMEVB) for connectivity to a host computer using a USB interface.

2.2 Related Documents

The following documents are recommended for more fully understanding the products and systems described in this documents.

- MPU-6000 Product Specification
- AK8975/AK8975C Datasheet

3. MPU-6000 9-Axis EV Board Overview

The MPU-6000 9-Axis EV Board contains the MPU-6000 digital Motion Processing Unit and the AKM compass. Additionally, it contains a number of 'solder-across' jumper points that permit several circuit configurations.

Please refer to Figures 1 & 5. The EV Board is populated on its top side only for ease of measurement access. The 10x2 customer header connector (JP14) is designed to connect with the InvenSense ARM Evaluation Board (INVARMEVB), which is a host microcontroller board useful for adapting the MPU-6000 9-Axis EV Board to a personal computer via its USB port.

The 5x2 extension factory header (JP13) is intended for connecting additional devices to the EV Board, such as a camera image stabilization processor, or a digital-output compass, etc. The 3-pin power selection header (JP12) is used to select which voltage supply is fed to the MPU-6000. The 3-pin VLOGIC selection header (JP6) is used to select between 3 V and VDD as the logic supply voltage.



3.1 MPU-6000 Key Function and Pin-outs

The MPU-60X0 EVB is a fully-tested evaluation board, providing for quick evaluation of the MPU-60X0's X-, Y-, and Z- axis angular rate gyroscope + X-, Y-, and Z- axis accelerometer. MPU-60X0 has a primary interface to talk to the application processor and a secondary interface to communicate to an external sensor. MPU-60X0 EVB comes preloaded with a AKM 3-axis compass to let the user experience a 9-axis sensor fusion output from MPU-60X0's Motion Processing Unit. The MPU-60X0 uses InvenSense's proprietary MEMS technology with driven vibrating masses to produce a functionally complete, low-cost motion sensor. All required conditioning electronics are integrated into a single chip measuring 4 x 4 x 0.9mm. It incorporates X-, Y- and Z-axis low-pass filters and an EEPROM for on-chip factory calibration of the sensor. Factory trimmed scale factors eliminate the need for external active components and end-user calibration. A built-in Proportional-To-Absolute-Temperature (PTAT) sensor provides temperature compensation information. The product is lead-free and Green Compliant.

3.2 MPU-6000 vs. MPU-6050

The MPU-6000 and MPU-6050 are identical, except that the MPU-6050 supports the I²C serial interface only, and has a separate VLOGIC reference pin. The MPU-6000 supports both I²C and SPI interfaces and has a single supply pin, VDD, which is both the device's logic reference supply and the analog supply for the part. The table below outlines these differences:

Table 1. Primary Differences between MPU-6000 and MPU-6050

Part / Item	MPU-6000	MPU-6050
VDD	2.5V±5%, 3.0V±5%, or 3.3V±5%.	2.5V±5%, 3.0V±5%, or 3.3V±5%.
VLOGIC	n/a	1.71V to VDD
Serial Interfaces Supported	I ² C, SPI	I ² C
Pin 8	/CS	VLOGIC
Pin 9	AD0/SDO	AD0
Pin 23	SCL/SCLK	SCL
Pin 24	SDA/SDI	SDA

3.3 MPU-6000 Bus Connection

The MPU-60X0 EVB communicates to a system processor through the customer header using the I²C serial interface. The device always acts as a slave when communicating to the system processor.

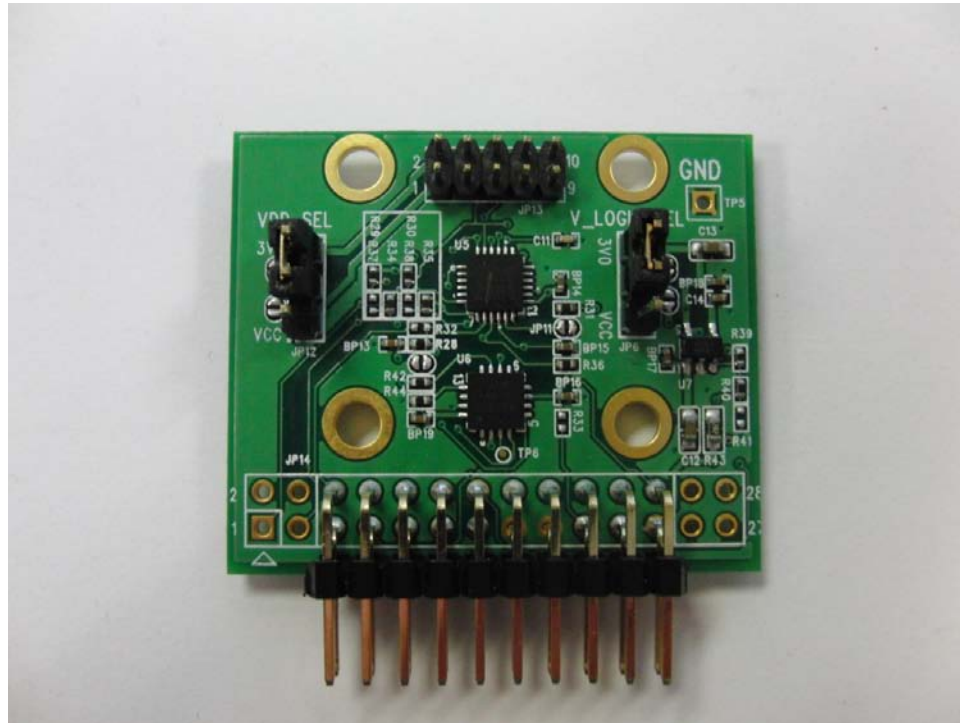
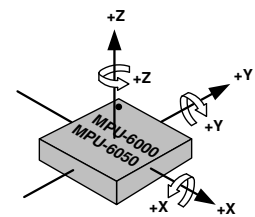
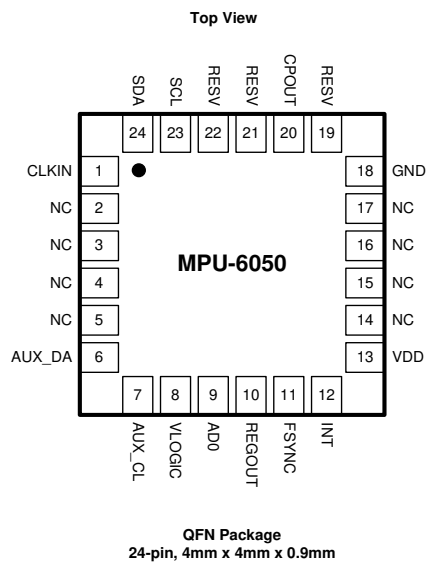
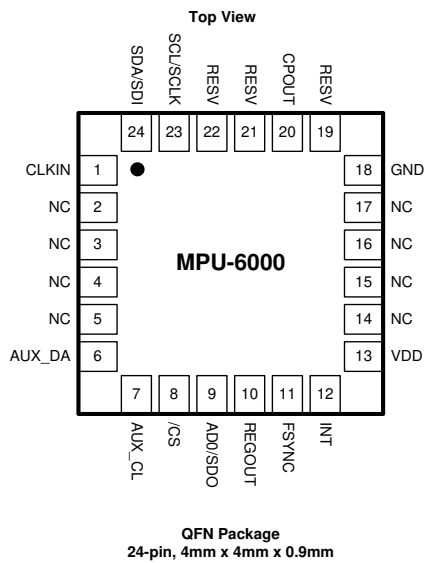
Figure 1. Top side of the MPU-60X0 9-Axis EV Board

Orientation of Axes of Sensitivity and Polarity of Rotation

Figure 2. MPU-6000 QFN Package (Top View) 24-pin 4mm x 4mm x 0.9mm & Axis Orientation

4. Schematic

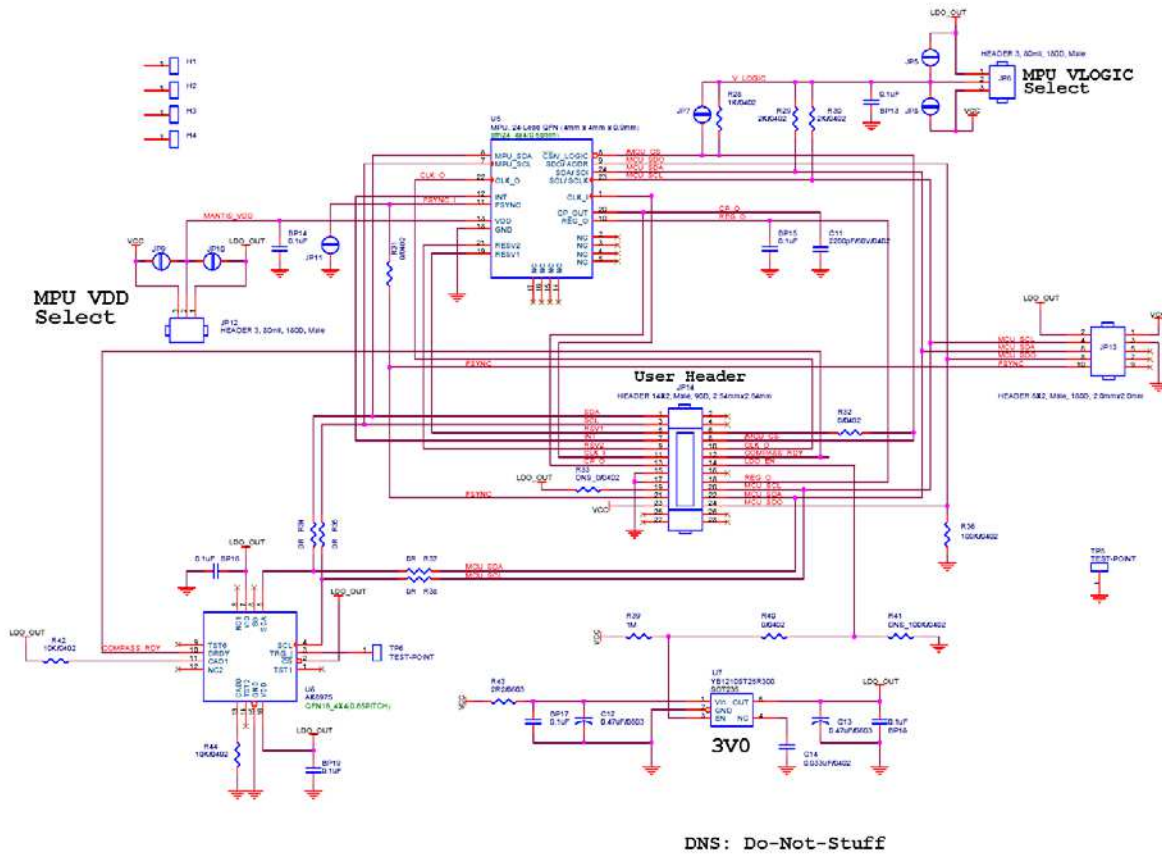



5. Bill of Materials

Table 2. Bill of Material

Item	Quantity	Reference	Part	PCB Footprint
1	7	BP13, BP14, BP15, BP16, BP17, BP18, BP19	0.1uF	C0402
2	1	C11	2200pF/50V/0402	C0402
3	2	C13, C12	0.47uF/0603	C0603
4	1	C14	0.033uF/0402	C0402
7	2	JP6, JP12	HEADER 3, 80mil, 180D, Male	J79\3S
8	1	JP13	HEADER 5X2, Male, 180D, 2.0mmx2.0mm	SIP2X5N2
9	1	JP14	HEADER 14X2, Male, 90D, 2.54mmx2.54mm	HDB2X14NRA
10	1	R28	1K/0402	R0402
11	2	R30, R29	2K/0402	R0402
12	3	R31, R32, R40	0/0402	R0402
14	4	R34, R35, R37, R38	0R	R0402
15	1	R36	100K/0402	R0402
16	1	R39	1M	R0402
18	2	R44, R42	10K/0402	R0402
19	1	R43	2R2/0603	R0603
22	1	U5	MPU, 24-Lead QFN (4mm x 4mm x 0.9mm)	qfn24_4x4(0.5pitch)
23	1	U6	AK8975	QFN16_4X4(0.65PITCH)
24	1	U7	YB1210ST25R300	SOT235

6. Power Supply Connections

JP6 and JP12 are 3 header-pin plug-in jumpers which allow users to select between on-board LDO and external DC supply for powering the MPU-60X0. For details, please refer Table 3. Power Selection Jumpers.

The on-board 3.0V LDO (Low-dropout voltage regulator) is a low-noise version. Its output is called 3V0 on the schematic, and using it will assure that the gyroscope and accelerometer performance will meet intended specifications.

Selecting the raw Vcc line to power the chip is generally done while designing and evaluating an embedded platform, where the host processor and related electronics needs full control over the motion processing chipset's power supply.

When the user intends to use the on board LDO 3V0 power, external Vcc must be provided with atleast 3.7V to ensure the LDO works properly.

If the user provides Vcc with 5V, JP6 and JP12 must be set as "1-2 short" since the MPU-60X0 VDD and VLOGIC operation range is 2.1V to 3.6V.

7. MPU-60X0 EVB connector signals description

Table 3. Power Selection Jumpers

JP6 Pin Number	Signal description
1-2 short	MPU-6050 VLOGIC = 3V (from LDO, Vcc>3.7 V)
2-3 short	MPU-6050 VLOGIC = Vcc (from external source)
JP12 Pin Number	Signal description
1-2 short	MPU-60X0 VDD = 3V (from LDO, Vcc>3.7V)
2-3 short	MPU-60X0 VDD = Vcc (from external source)

Table 4. User Interface Connector Signals

JP14 Pin Number	Signal description
1	Reserved
3	Reserved
5	Reserved
7	INT, MPU-60X0 INTERRUPT output to controller
9	Reserved
11	MPU-60X0 CLK_I, External Clock Input
13	MPU-60X0 CPOUT, Charge pump Output
15	GND
17	GND
19	3V
21	MPU-60X0 FSYNC
23	Receive power from ARM-7 Controller Board or external. It should be 5V, with >200mA



JP14 Pin Number	Signal description
27	NC
2	NC
4	NC
6	NC
8	MPU-60X0 SPI CS
10	Reserved
12	NC
14	MPU-60X0 EVB on board LDO enable
16	NC
18	MPU-60X0 REGOUT
20	MPU-60X0 I ² C SCL or MPU-6000 SPI SCLK
22	MPU-60X0 I ² C SDA or MPU-6000 SPI SDI
24	MPU-60X0 I ² C Addr or MPU-6000 SPI SDO
26	NC
28	NC
25	NC

Table 5. Extended Factory Connector

JP13 Pin Number	Signal description
1	VCC, power from ARM-7 controller board or external power. It should be 5V, with >200mA
3	GND
5	NC
7	NC
9	NC
2	3V
4	MPU-60X0 I ² C SCL or MPU-6000 SPI SCLK
6	MPU-60X0 I ² C SDA or MPU-6000 SPI SDI
8	MPU-60X0 I ² C Addr or MPU-6000 SPI SDO
10	MPU-60X0 FSYNC

7.1 Connecting the FSYNC Line

The FSYNC line is intended for use in a camera's image-stabilization system. It is an input from the camera platform to the EV Board, and is intended to synchronize the MPU-60X0 serial bus transfer with the master timing set by the camera system. FSYNC can originate from the host processor via JP14 pin-21, or from JP13 pin-10. There is no external pull-up termination for the FSYNC line.

7.2 Serial bus Levels, Speeds and Terminations

The MPU-60X0 supports I²C up to 400kHz, and MPU-6000 supports SPI up to 1MHz serial clock rates. The I²C bus open drain pull up resistors are connected to either 3.0V or an external provided Vcc (3V or 5V depends on user). The pull up level is selected by JP6. Please refer to Table 3. Power Selection Jumpers.

8. Data Gathering Options

The MPU-60X0 Digital Sensor Data is available at the User Header. Alternatively, for connectivity with a host PC, an InvenSense ARM Processor Board may be used.

8.1 Connection to ARM EVB

For communications via USB to a host computer, the MPU-60X0 EVB can be connected to InvenSense's ARM processor board, the INV-ARMEVB.

The photo below shows the connection of MPU-60X0 to INV-ARMEVB. Connection between the two boards is made via the user header.



Figure 4. MPU-60X0 EVB connected to ARM Board

8.2 Use of MPU-60X0 without ARM EVB board

I²C and SPI signals are available on JP13 and JP14. User can develop tools to communicate with MPU-60X0. There is no bus mode selection needed.

9. Special Instructions

9.1 Electrostatic Discharge Sensitivity

The MPU-6050 gyro+accel can be permanently damaged by an electrostatic discharge. ESD precautions for handling and storage are recommended.

9.2 Board Layout

The MPU-60X0 EV board is a 4 layer PCB with 38mm x 32mm dimension.

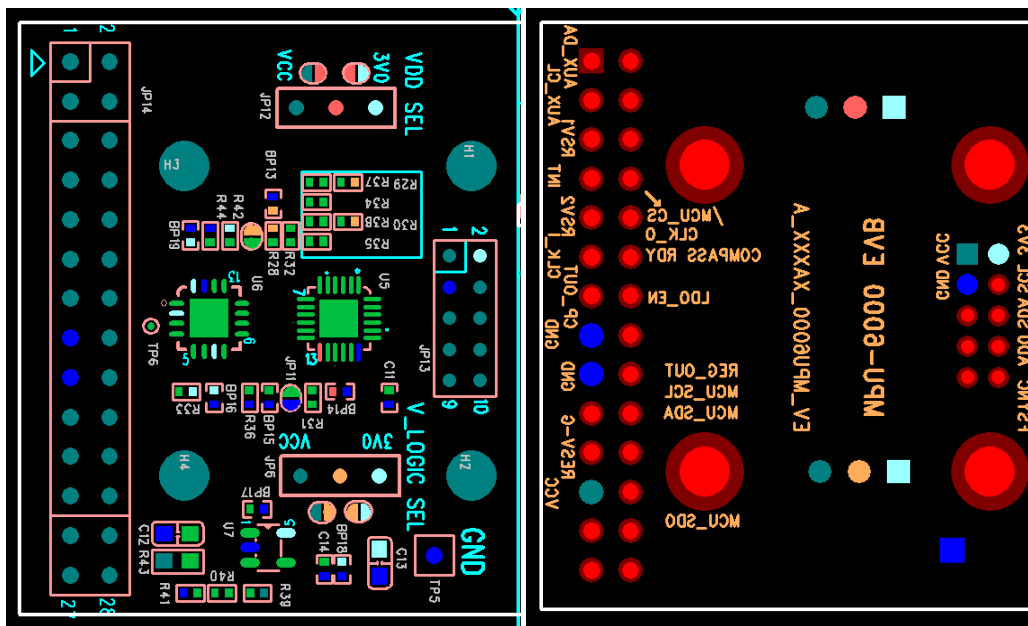

Figure 5. MPU-60X0 Board Layout: Top View & Bottom View



This information furnished by InvenSense is believed to be accurate and reliable. However, no responsibility is assumed by InvenSense for its use, or for any infringements of patents or other rights of third parties that may result from its use. Specifications are subject to change without notice. InvenSense reserves the right to make changes to this product, including its circuits and software, in order to improve its design and/or performance, without prior notice. InvenSense makes no warranties, neither expressed nor implied, regarding the information and specifications contained in this document. InvenSense assumes no responsibility for any claims or damages arising from information contained in this document, or from the use of products and services detailed therein. This includes, but is not limited to, claims or damages based on the infringement of patents, copyrights, mask work and/or other intellectual property rights.

Certain intellectual property owned by InvenSense and described in this document is patent protected. No license is granted by implication or otherwise under any patent or patent rights of InvenSense. This publication supersedes and replaces all information previously supplied. Trademarks that are registered trademarks are the property of their respective companies. InvenSense sensors should not be used or sold in the development, storage, production or utilization of any conventional or mass-destructive weapons or for any other weapons or life threatening applications, as well as in any other life critical applications such as medical equipment, transportation, aerospace and nuclear instruments, undersea equipment, power plant equipment, disaster prevention and crime prevention equipment.

InvenSense™ is a registered trademark of InvenSense, Inc.; MPU-60X0™, MPU-6000™, and MPU-6050™ are trademarks of InvenSense, Inc.

©2010 InvenSense, Inc. All rights reserved.

