



Chipsmall Limited consists of a professional team with an average of over 10 year of expertise in the distribution of electronic components. Based in Hongkong, we have already established firm and mutual-benefit business relationships with customers from,Europe,America and south Asia,supplying obsolete and hard-to-find components to meet their specific needs.

With the principle of "Quality Parts,Customers Priority,Honest Operation,and Considerate Service",our business mainly focus on the distribution of electronic components. Line cards we deal with include Microchip,ALPS,ROHM,Xilinx,Pulse,ON,Everlight and Freescale. Main products comprise IC,Modules,Potentiometer,IC Socket,Relay,Connector.Our parts cover such applications as commercial,industrial, and automotives areas.

We are looking forward to setting up business relationship with you and hope to provide you with the best service and solution. Let us make a better world for our industry!



Contact us

Tel: +86-755-8981 8866 Fax: +86-755-8427 6832

Email & Skype: info@chipsmall.com Web: www.chipsmall.com

Address: A1208, Overseas Decoration Building, #122 Zhenhua RD., Futian, Shenzhen, China





InvenSense Inc.
1197 Borregas, Sunnyvale, CA 94089 U.S.A
Tel: +1 (408) 988-7339 Fax: +1 (408) 9888104
Website: www.invensense.com

Document Number: AN-MPU-9250IMF-01
Revision: 1.0
Release Date: 09/18/2012

MPU-9250™ CA-SDK™ Reference Board User Guide

Table of Contents

REVISION HISTORY	3
1 PURPOSE	4
2 REFERENCE DOCUMENTS AND SOFTWARE PACKAGES	4
3 DESCRIPTION	4
3.1 INVENSENSE NINE-AXIS MOTIONTRACKING DEVICE (MPU-9250).....	5
3.2 EMBEDDED MICROCONTROLLER (MSP430).....	5
3.3 BLUETOOTH MODULE (BR-LE4.0-D2)	5
3.4 SERIAL FLASH	5
3.5 EXTERNAL SENSORS.....	5
5 BOARD HARDWARE DESIGN	8
5.1 SCHEMATICS	8
5.2 PCB LAYOUT:	9
5.3 POWER SUPPLY:.....	9
6 INSTALLATION GUIDE	10
6.1 HARDWARE AND SOFTWARE SETUP	10

Revision History

Revision Date	Revision	Description
09/18/12	1.0	Initial Release

1 Purpose

The InvenSense CA-SDK is designed to enable rapid commercialization of wearable sensor solutions for fitness, health, and sports applications. It delivers a sensor platform capable of tracking 10-degrees-of-freedom by combining the MPU-9250 9-axis MotionTracking device, a host of external sensors, microcontroller, Bluetooth radio module, serial flash, a rechargeable battery, and battery charger that is ideal for developing wearable sensor applications.

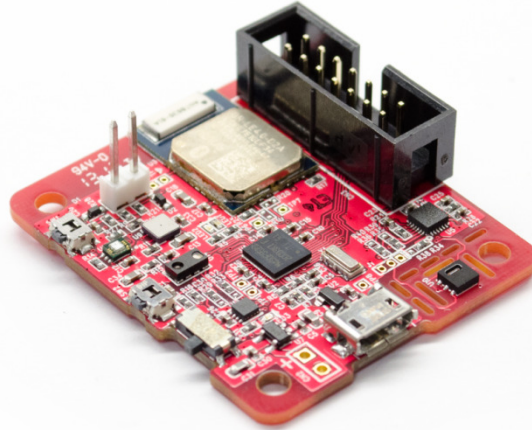

2 Reference Documents and software packages

- 2.1 **InvenSense CA-SDK 5.1.1 User Guide:** This document covers details on bringing up the CA-™ SDK.
- 2.2 **Embedded MotionApps v5.1.1 APIs Specification:** This document covers the Embedded MotionApps specification and functional modules.
- 2.3 **CA-SDK with eMPL 5.1.1 release package:** This is the firmware which is running Embedded MotionApps v5.1

3 Description

The CA-SDK provides a total solution encompassing hardware and software, with a full ten degrees of freedom from the InvenSense MotionTracking™ device, the MPU-9250. The sensors are interfaced via the I²C serial digital interface to an MSP430 MCU. A Bluetooth radio module that enables wireless connectivity is interfaced through the UART to the MCU. There is a serial flash that interfaces to the MCU using the SPI interface. Also included, is a 110mA-hr rechargeable battery and charger circuitry, that can provide up to 4 hours of wireless data streaming. Streaming is supported through the wireless interface, and a micro USB connector provides a wired interface to the SDK. The SDK is well suited for embedded applications such as activity detection for fitness, sports performance, and medical applications such as rehab and outpatient monitoring. The board provides everything you need for sensing and communication. The following components are incorporated into this development board, and detailed explanations of their operation can be obtained from the relevant partner's component data sheets.

3.1 InvenSense Nine-Axis MotionTracking Device (MPU-9250)

MPU-9250 is a single-chip, digital output, nine-axis MEMS gyroscope, accelerometer, and compass IC optimized for wearable sensor applications. The integrated Digital Motion Processor (DMP™) inside the chip can perform 6-axis MotionFusion™ and calibration routines inside the MPU. The chip supports an I²C interface for connecting to the MCU. The on chip temperature sensor can enable software temperature compensation for the gyro bias. The embedded AK8963 compass sensor die incorporates magnetic sensors for detecting terrestrial magnetism in the X-axis, Y-axis, and Z-axis. The MPU-9250 contains a sensor driving circuit, a signal amplifier chain, and an arithmetic circuit for processing the signal from each sensor.

3.2 Embedded Microcontroller (MSP430)

The Texas Instruments MSP430 family of ultra-low power microcontrollers consists of several devices featuring different sets of peripherals targeted for various applications. The architecture, combined with extensive low-power modes, is optimized to achieve extended battery life in portable measurement applications. The device features a powerful 16-bit RISC CPU, 16-bit registers, and constant generators that contribute to maximum code efficiency. The digitally controlled oscillator (DCO) allows wake-up from low-power modes to active mode in 3.5 μs (typical). The MSP430F5528IZQE, has an integrated USB and PHY supporting USB 2.0, four 16-bit timers, a high-performance 12-bit analog-to-digital converter (ADC), two universal serial communication interfaces (USCI), hardware multiplier, DMA, real-time clock module with alarm capabilities, and 63 I/O pins.

3.3 Bluetooth module (BR-LE4.0-D2)

- Integrated AT.s command stack for external control via UART or RF, with master/slave support and serial (BRSP) and battery (BAS) profiles. BRSP allows the user to stream data over LE similar to the way SPP works on Classic *Bluetooth* devices, but at a much lower maximum data rate.
- UART (2 or 4 wire with CTS/RTS, 9600 to 460.8K baud), SPI, and I2C data interfaces.
- 12-Bit ADC with 8 channels, RTC, battery monitor, temperature sensor, watchdog timer.
- Software adjustable transmitter power (-23dBm to 10.5dBm) for short to long range applications.
- Low power consumption: *40mA 4dB TX, RX 38.5mA, 590uA idle w/ UART active, and 90uA deep sleep.*
- 10 meter distance
- Secure and robust communication link:
 - ✓ FHSS (Frequency Hopping Spread Spectrum)
 - ✓ 24-bit CRC Error correction for guaranteed packet delivery
 - ✓ AES-128 bit encryption using CCM for encryption and authentication of packets.
- Operating temperature range: -40~+85°C.

3.4 Serial Flash

The CA-™ SDK has a 256Mbit serial flash integrated for storing activity data. For information on the serial flash, please refer to [MX25L25635E, LLD, v0.3.zip](#) on the Macronix website

3.5 External Sensors. Datasheets can be found inside the CA-SDK zip file available for download in the Developers Corner. http://www.invensense.com/developers/index.php?_r=default

- **Sensirion SHT21:** Temperature and humidity sensors. CA-SDK software provides the driver for retrieving the raw sensor data from the sensor.
- **Capella CM36682:** Light and proximity sensors. CA-SDK software provides the driver for retrieving the raw sensor data from the sensors. The light sensor is provided as an interface example and the proximity sensor is disabled by default for power concerns.



- **Capella CM3512:** UVI (ultra violet index) sensor. CA-SDK software provides the driver for retrieving the UV index from the sensor.
- **ALSP HSPPA032A:** Pressure sensor. CA-SDK software provides the driver for retrieving the pressure values.

4. System Block Diagram

Figure 1 displays the CA- SDK system block diagram.

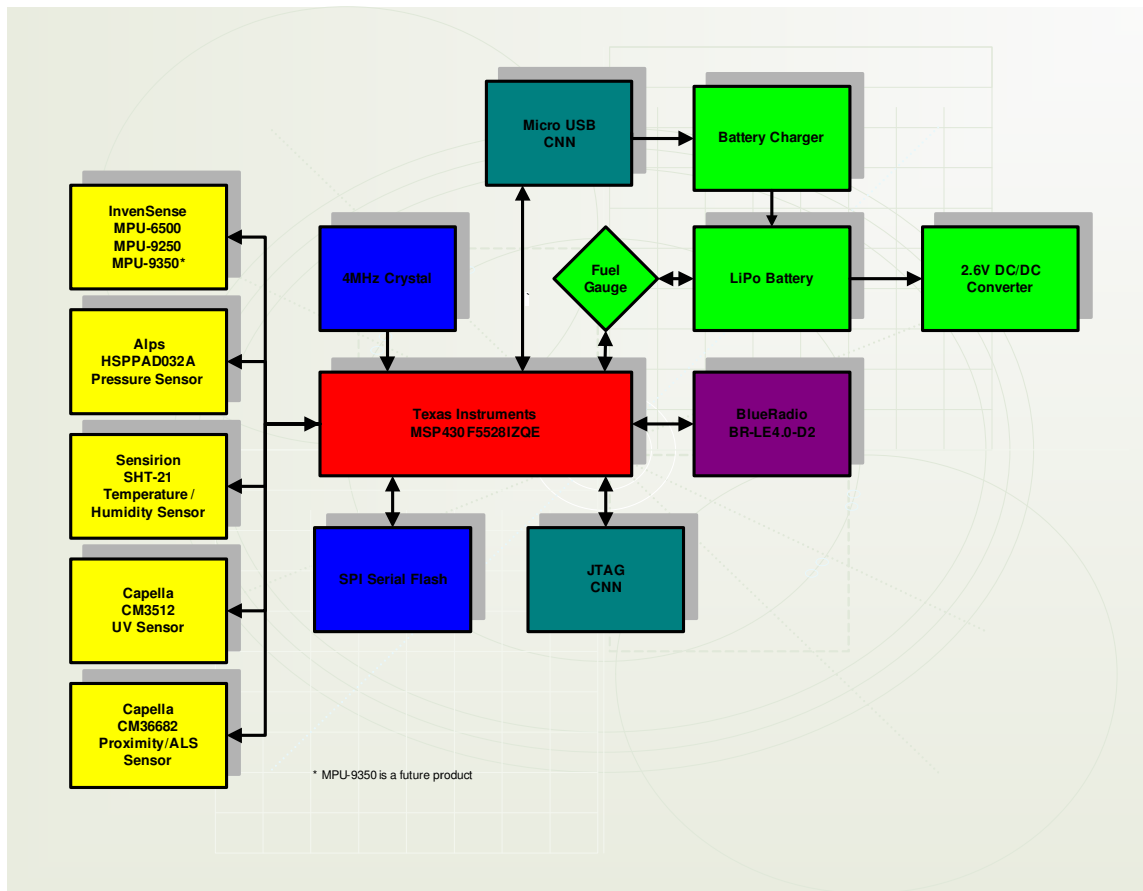

Figure 1 System Block Diagram

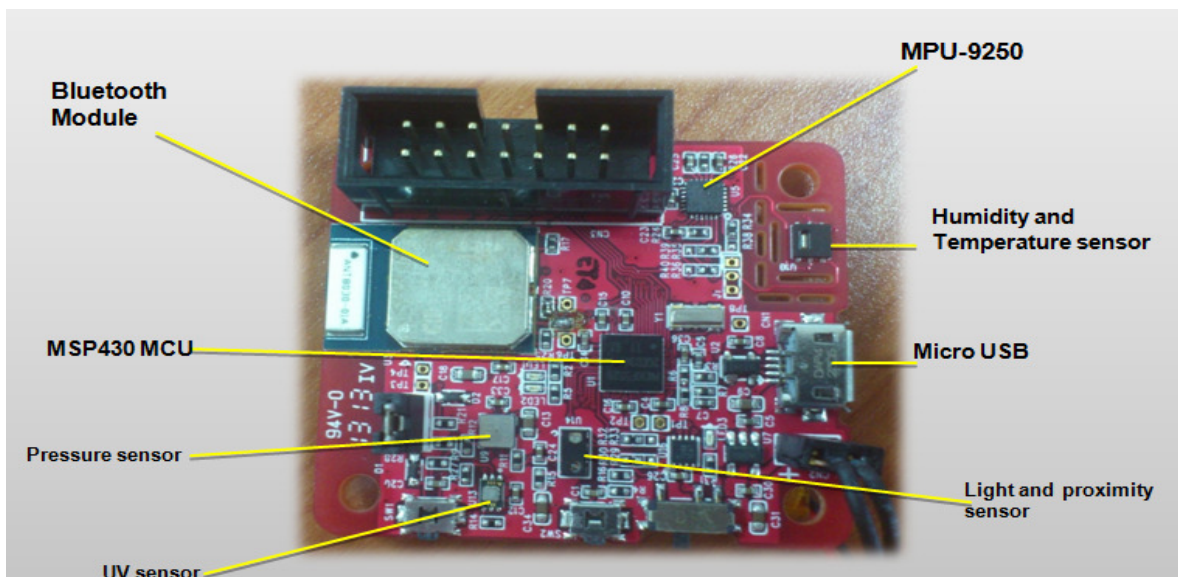

Figure 2 Components on Board

5 Board Hardware Design

5.1 Schematics

Table 1 gives the I2C addresses for sensors. Figure 3 shows the schematic for the CA- SDK board.

Sensor	7 bit I2C Slave Address
MPU-9250	0x68
	0x77

Table 1 Sensor I2C Device Address

Figure 3 Board Schematic. (Also Located in the CA- with eMPL 5.1 Release Package)

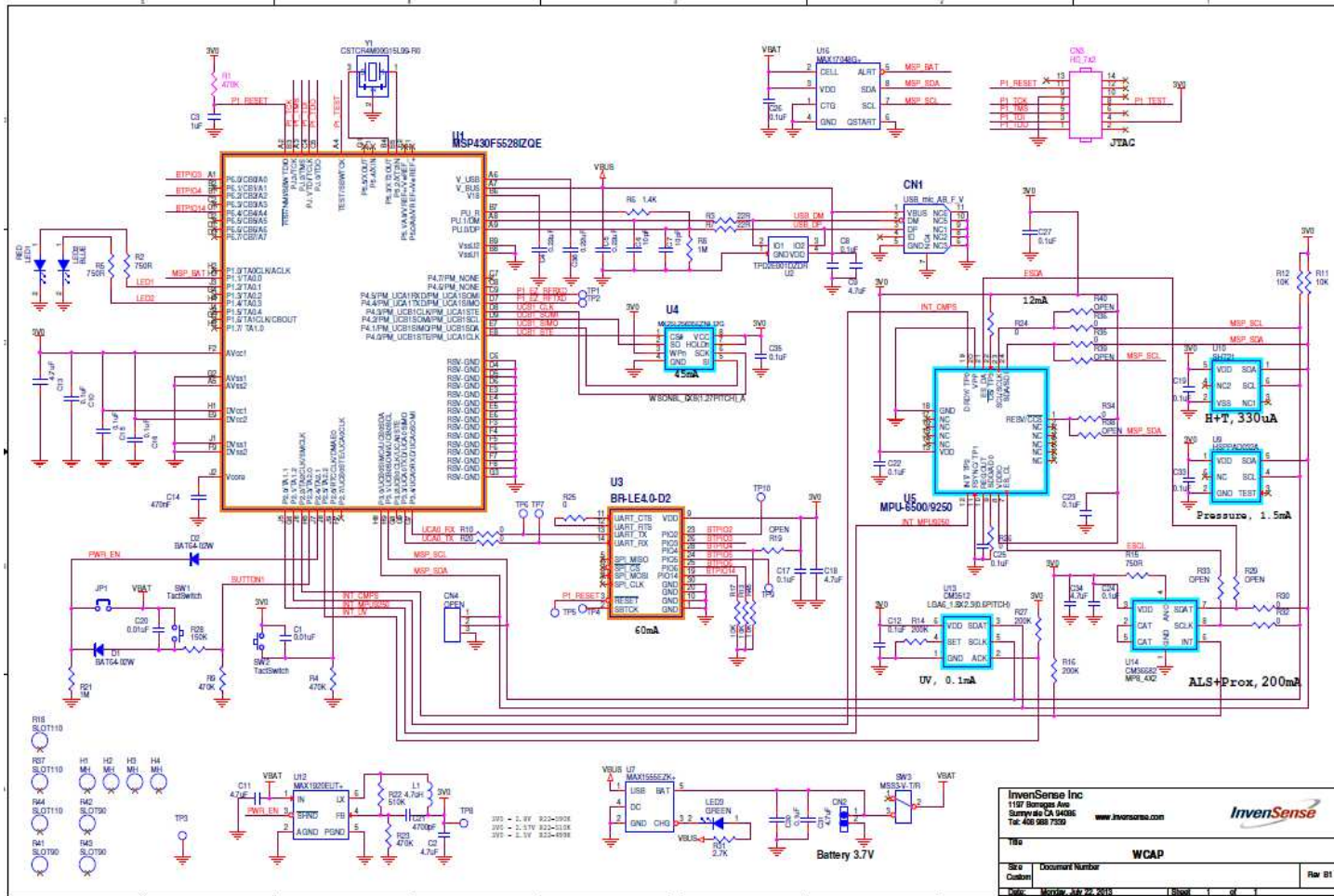

InvenSense Inc
1157 Serrano Ave
Sunnyvale CA 94085
Tel: 408 988 7529
www.invensense.com

InvenSense

Doc #	Document Number	Rev
WCAP		B1
Date:	March 22, 2015	1 of 1

	MPU-9250™ CA-SDK™ Reference Board User Guide	Document Number: AN-MPU-9250IMF-01 Revision: 1.0 Release Date: 09/18/2012
---	--	---

6 Installation Guide

6.1 Hardware and Software Setup

Please refer to the InvenSense CA- 5.1.1 SDK User Guide for hardware and software setup instructions.

This information furnished by InvenSense is believed to be accurate and reliable. However, no responsibility is assumed by InvenSense for its use, or for any infringements of patents or other rights of third parties that may result from its use. Specifications are subject to change without notice. InvenSense reserves the right to make changes to this product, including its circuits and software, in order to improve its design and/or performance, without prior notice. InvenSense makes no warranties, neither expressed nor implied, regarding the information and specifications contained in this document. InvenSense assumes no responsibility for any claims or damages arising from information contained in this document, or from the use of products and services detailed therein. This includes, but is not limited to, claims or damages based on the infringement of patents, copyrights, mask work and/or other intellectual property rights.

Certain intellectual property owned by InvenSense and described in this document is patent protected. No license is granted by implication or otherwise under any patent or patent rights of InvenSense. This publication supersedes and replaces all information previously supplied. Trademarks that are registered trademarks are the property of their respective companies. InvenSense sensors should not be used or sold in the development, storage, production or utilization of any conventional or mass-destructive weapons or for any other weapons or life threatening applications, as well as in any other life critical applications such as medical equipment, transportation, aerospace and nuclear instruments, undersea equipment, power plant equipment, disaster prevention and crime prevention equipment.

The information in this document is preliminary and subject to change without notice. InvenSense assumes no liability for infringement of any patent, intellectual property or use of any information contained herein. InvenSense, MotionTracking, MotionProcessing, MotionProcessor, Nasiri-Fabrication, MotionFusion, MotionApps, CA-, DMP, and the InvenSense logo are trademarks of InvenSense, Inc. Other company and product names may be trademarks of the respective companies with which they are associated

©2012 InvenSense, Inc. All rights reserved.

