



Chipsmall Limited consists of a professional team with an average of over 10 year of expertise in the distribution of electronic components. Based in Hongkong, we have already established firm and mutual-benefit business relationships with customers from,Europe,America and south Asia,supplying obsolete and hard-to-find components to meet their specific needs.

With the principle of “Quality Parts,Customers Priority,Honest Operation,and Considerate Service”,our business mainly focus on the distribution of electronic components. Line cards we deal with include Microchip,ALPS,ROHM,Xilinx,Pulse,ON,Everlight and Freescale. Main products comprise IC,Modules,Potentiometer,IC Socket,Relay,Connector.Our parts cover such applications as commercial,industrial, and automotives areas.

We are looking forward to setting up business relationship with you and hope to provide you with the best service and solution. Let us make a better world for our industry!



Contact us

Tel: +86-755-8981 8866 Fax: +86-755-8427 6832

Email & Skype: info@chipsmall.com Web: www.chipsmall.com

Address: A1208, Overseas Decoration Building, #122 Zhenhua RD., Futian, Shenzhen, China



50 kPa On-Chip Temperature Compensated and Calibrated Silicon Pressure Sensors

The MPX2053 series devices are silicon piezoresistive pressure sensors that provide a highly accurate and linear voltage output directly proportional to the applied pressure. A single, monolithic silicon diaphragm with the strain gauge and an integrated thin-film resistor network. Precise span and offset calibration with temperature compensation are achieved by laser trimming.

MPX2053 Series
 0 to 50 kPa (0 to 7.25 psi)
 40 mV Full Scale
 (Typical)

Features

- Temperature Compensated Over 0°C to +85°C
- Easy-to-Use Chip Carrier Package Options
- Ratiometric to Supply Voltage
- Gauge Ported and Non Ported Options
- Available in Easy-to-Use Tape & Reel
- Differential and Gauge Pressure Options

Application Examples

- Pump/Motor Control
- Robotics
- Level Detectors
- Medical Diagnostics
- Pressure Switching
- Blood Pressure Measurement

ORDERING INFORMATION								
Device Name	Case No.	# of Ports			Pressure Type			Device Marking
		None	Single	Dual	Gauge	Differential	Absolute	
Small Outline Package (MPXV2053G Series)								
MPXV2053GP	1369		•		•			MPXV2053GP
MPXV2053DP	1351			•		•		MPXV2053DP
Unibody Package (MPX2053 Series)								
MPX2053D	344	•				•		MPX2053D
MPX2053DP	344C			•		•		MPX2053DP
MPX2053GP	344B		•		•			MPX2053GP
MPAK Package (MPXM2053 Series)								
MPXM2053D	1320	•				•		MPXM2053D
MPXM2053DT1	1320	•				•		MPXM2053D
MPXM2053GS	1320A		•		•			MPXM2053GS
MPXM2053GST1	1320A		•		•			MPXM2053GS

UNIBODY PACKAGES



MPX2053D
CASE 344-15



MPX2053GP
CASE 344B-01

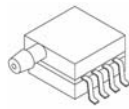

MPX2053DP
CASE 344C-01

SMALL OUTLINE PACKAGES

MPXV2053GP
CASE 1369-01

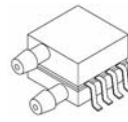

MPXV2053DP
CASE 1351-01

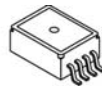
MPAK PACKAGES

MPXM2053D/DT1
CASE 1320-02

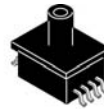

MPXM2053GS/GST1
CASE 1320A-02

Operating Characteristics

Table 1. Operating Characteristics ($V_S = 10 V_{DC}$, $T_A = 25^\circ C$ unless otherwise noted, $P1 > P2$)

Characteristic	Symbol	Min	Typ	Max	Units
Pressure Range ⁽¹⁾	P_{OP}	0	—	50	kPa
Supply Voltage ⁽²⁾	V_S	—	10	16	V_{DC}
Supply Current	I_O	—	6.0	—	mA _{dc}
Full Scale Span ⁽³⁾	V_{FS}	38.5	40	41.5	mV
Offset ⁽⁴⁾	—	-1.0	—	1.0	mV
Sensitivity	—	$\Delta V/\Delta P$	—	0.8	—
Non-Linearity	—	-0.6	—	0.4	% V_{FS}
Pressure Hysteresis (0 to 50 kPa)	—	—	± 0.1	—	% V_{FS}
Temperature Hysteresis (-40° to 125°C)	—	—	± 0.5	—	% V_{FS}
Temperature Coefficient of Full Scale	TCV_{FS}	-2.0	—	2.0	% V_{FS}
Temperature Coefficient of Offset	TCV_{OFF}	-1.0	—	1.0	mV
Input Impedance	Z_{IN}	1000	—	2500	Ω
Output Impedance	Z_{OUT}	1400	—	3000	Ω
Response Time ⁽⁵⁾ (10% to 90%)	t_R	—	1.0	—	ms
Warm-Up Time	—	—	20	—	ms
Offset Stability ⁽⁶⁾	—	—	± 0.5	—	% V_{FS}

- 1.0 kPa (kiloPascal) equals 0.145 psi.
- Device is ratiometric within this specified excitation range. Operating the device above the specified excitation range may induce additional error due to device self-heating.
- Full Scale Span (V_{FSS}) is defined as the algebraic difference between the output voltage at full rated pressure and the output voltage at the minimum rated pressure.
- Offset (V_{off}) is defined as the output voltage at the minimum rated pressure.
- Response Time is defined as the time for the incremental change in the output to go from 10% to 90% of its final value when subjected to a specified step change in pressure.
- Offset stability is the product's output deviation when subjected to 1000 hours of Pulsed Pressure, Temperature Cycling with Bias Test.

Maximum Ratings

Table 2. Maximum Ratings⁽¹⁾

Rating	Max Value	Unit
Supply Voltage	16	V
Pressure ($P1 > P2$)	200	kPa
Storage Temperature	-40 to +125	$^\circ C$
Operating Temperature Range	-40 to +125	$^\circ C$

- Exposure beyond the specified limits may cause permanent damage or degradation to the device.

Figure 1 shows a block diagram of the internal circuitry integrated on a pressure sensor chip.

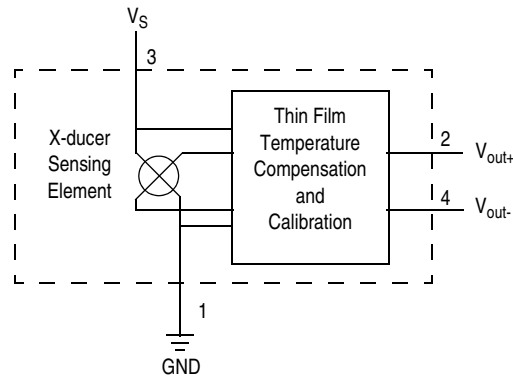

Figure 1. Temperature Compensated Pressure Sensor Schematic

Voltage Output versus Applied Differential Pressure

The differential voltage output of the sensor is directly proportional to the differential pressure applied.

The output voltage of the differential or gauge sensor increases with increasing pressure applied to the pressure

side relative to the vacuum side. Similarly, output voltage increases as increasing vacuum is applied to the vacuum side relative to the pressure side.

On-Chip Temperature Compensation and Calibration

Figure 2 shows the minimum, maximum and typical output characteristics of the MPX2053 series at 25°C. The output is directly proportional to the differential pressure and is essentially a straight line.

A silicone gel isolates the die surface and wire bonds from the environment, while allowing the pressure signal to be transmitted to the silicon diaphragm.

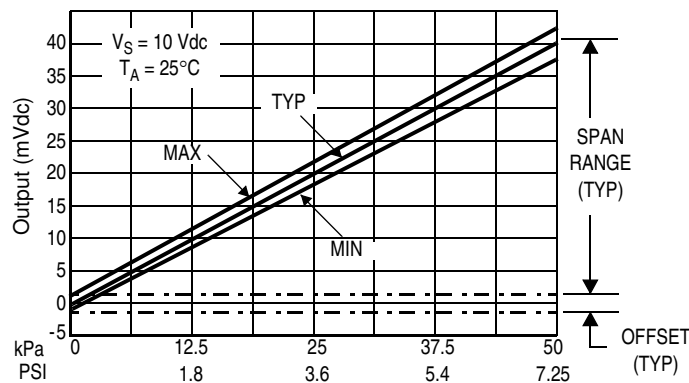

Figure 2. Output vs. Pressure Differential

LINEARITY

Linearity refers to how well a transducer's output follows the equation: $V_{out} = V_{off} + \text{sensitivity} \times P$ over the operating pressure range. There are two basic methods for calculating nonlinearity: (1) end point straight line fit (see Figure 3) or (2) a least squares best line fit. While a least squares fit gives the "best case" linearity error (lower numerical value), the calculations required are burdensome.

Conversely, an end point fit will give the "worst case" error (often more desirable in error budget calculations) and the calculations are more straightforward for the user. The specified pressure sensor linearities are based on the end point straight line method measured at the midrange pressure.

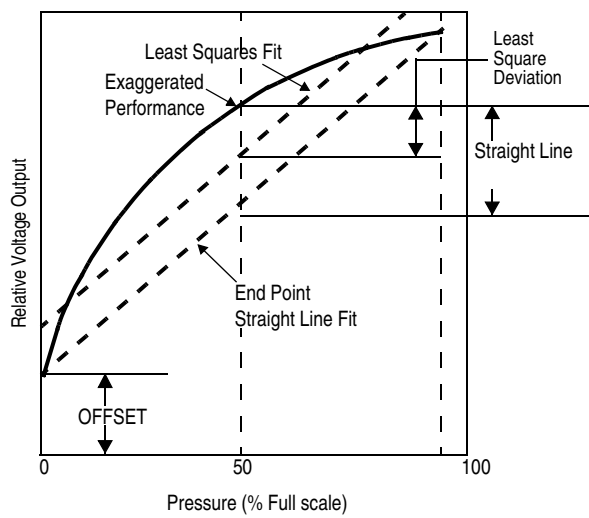

Figure 3. Linearity Specification Comparison

Figure 4 illustrates the differential or gauge configuration in the basic chip carrier (Case 344). A silicone gel isolates the die surface and wire bonds from the environment, while allowing the pressure signal to be transmitted to the silicon diaphragm.

are based on use of dry air as the pressure media. Media other than dry air may have adverse effects on sensor performance and long term reliability. Contact the factory for information regarding media compatibility in your application. Refer to application note AN3728, for more information regarding media compatibility.

The MPX2053 series pressure sensor operating characteristics and internal reliability and qualification tests

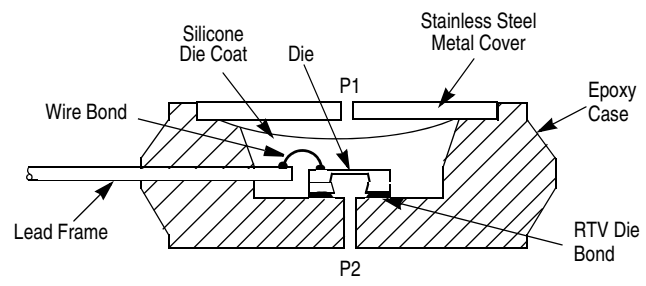
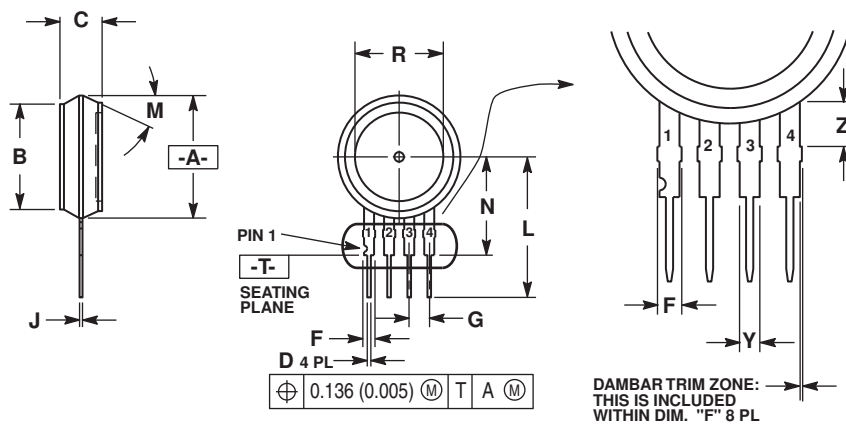

Figure 4. Unibody Package — Cross-Sectional Diagram (Not to Scale)

PACKAGE DIMENSIONS



- NOTES:
1. DIMENSIONING AND TOLERANCING PER ASME Y14.5M, 1994.
 2. CONTROLLING DIMENSION: INCH.
 3. DIMENSION -A- IS INCLUSIVE OF THE MOLD STOP RING. MOLD STOP RING NOT TO EXCEED 16.00 (0.630).

DIM	INCHES		MILLIMETERS	
	MIN	MAX	MIN	MAX
A	0.595	0.630	15.11	16.00
B	0.514	0.534	13.06	13.56
C	0.200	0.220	5.08	5.59
D	0.016	0.020	0.41	0.51
F	0.048	0.064	1.22	1.63
G	0.100 BSC		2.54 BSC	
J	0.014	0.016	0.36	0.40
L	0.695	0.725	17.65	18.42
M	30' NOM		30' NOM	
N	0.475	0.495	12.07	12.57
R	0.430	0.450	10.92	11.43
Y	0.048	0.052	1.22	1.32
Z	0.106	0.118	2.68	3.00

- | | | |
|--|---|---|
| STYLE 1:
PIN 1. GROUND
2. + OUTPUT
3. + SUPPLY
4. - OUTPUT | STYLE 2:
PIN 1. V _{cc}
2. - SUPPLY
3. + SUPPLY
4. GROUND | STYLE 3:
PIN 1. GND
2. -VOUT
3. VS
4. +VOUT |
|--|---|---|

CASE 344-15 ISSUE AA UNIBODY PACKAGE

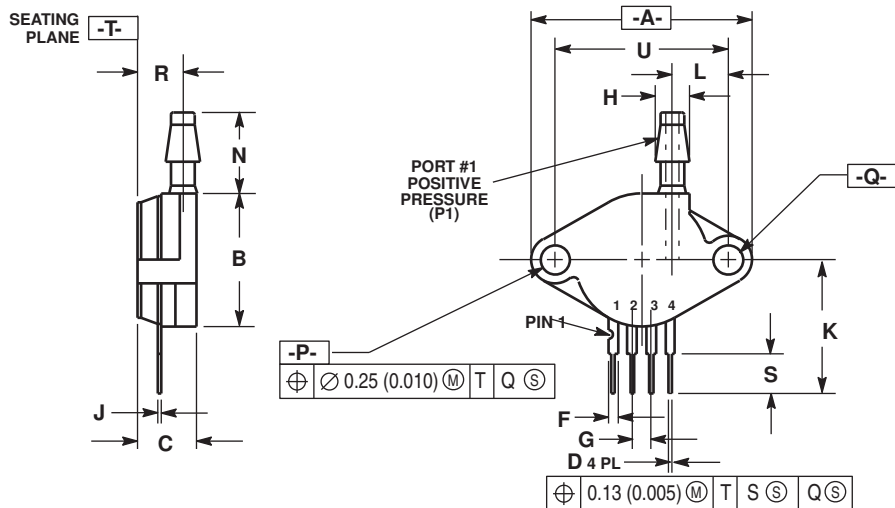

- NOTES:
1. DIMENSIONING AND TOLERANCING PER ANSI Y14.5M, 1982.
 2. CONTROLLING DIMENSION: INCH.

DIM	INCHES		MILLIMETERS	
	MIN	MAX	MIN	MAX
A	1.145	1.175	29.08	29.85
B	0.685	0.715	17.40	18.16
C	0.305	0.325	7.75	8.26
D	0.016	0.020	0.41	0.51
F	0.048	0.064	1.22	1.63
G	0.100 BSC		2.54 BSC	
H	0.182	0.194	4.62	4.93
J	0.014	0.016	0.36	0.41
K	0.695	0.725	17.65	18.42
L	0.290	0.300	7.37	7.62
N	0.420	0.440	10.67	11.18
P	0.153	0.159	3.89	4.04
Q	0.153	0.159	3.89	4.04
R	0.230	0.250	5.84	6.35
S	0.220	0.240	5.59	6.10
U	0.910 BSC		23.11 BSC	

- STYLE 1:
PIN 1. GROUND
2. + OUTPUT
3. + SUPPLY
4. - OUTPUT

CASE 344B-01 ISSUE B UNIBODY PACKAGE

PACKAGE DIMENSIONS

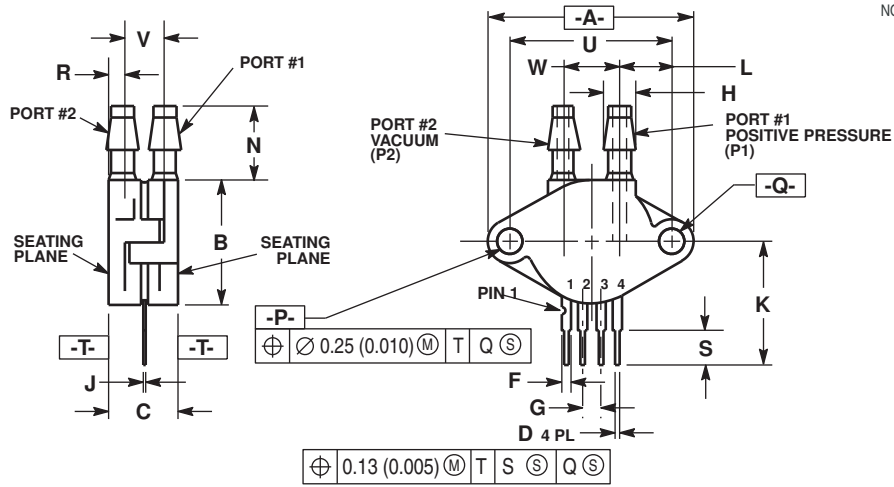

- NOTES:
 1. DIMENSIONING AND TOLERANCING PER ANSI Y14.5M, 1982.
 2. CONTROLLING DIMENSION: INCH.

DIM	INCHES		MILLIMETERS	
	MIN	MAX	MIN	MAX
A	1.145	1.175	29.08	29.85
B	0.685	0.715	17.40	18.16
C	0.405	0.435	10.29	11.05
D	0.016	0.020	0.41	0.51
F	0.048	0.064	1.22	1.63
G	0.100 BSC		2.54 BSC	
H	0.182	0.194	4.62	4.93
J	0.014	0.016	0.36	0.41
K	0.695	0.725	17.65	18.42
L	0.290	0.300	7.37	7.62
N	0.420	0.440	10.67	11.18
P	0.153	0.159	3.89	4.04
Q	0.153	0.159	3.89	4.04
R	0.063	0.083	1.60	2.11
S	0.220	0.240	5.59	6.10
U	0.910 BSC		23.11 BSC	
V	0.248	0.278	6.30	7.06
W	0.310	0.330	7.87	8.38

- STYLE 1:
 PIN 1: GROUND
 2. + OUTPUT
 3. + SUPPLY
 4. - OUTPUT

CASE 344C-01 ISSUE B UNIBODY PACKAGE

PACKAGE DIMENSIONS

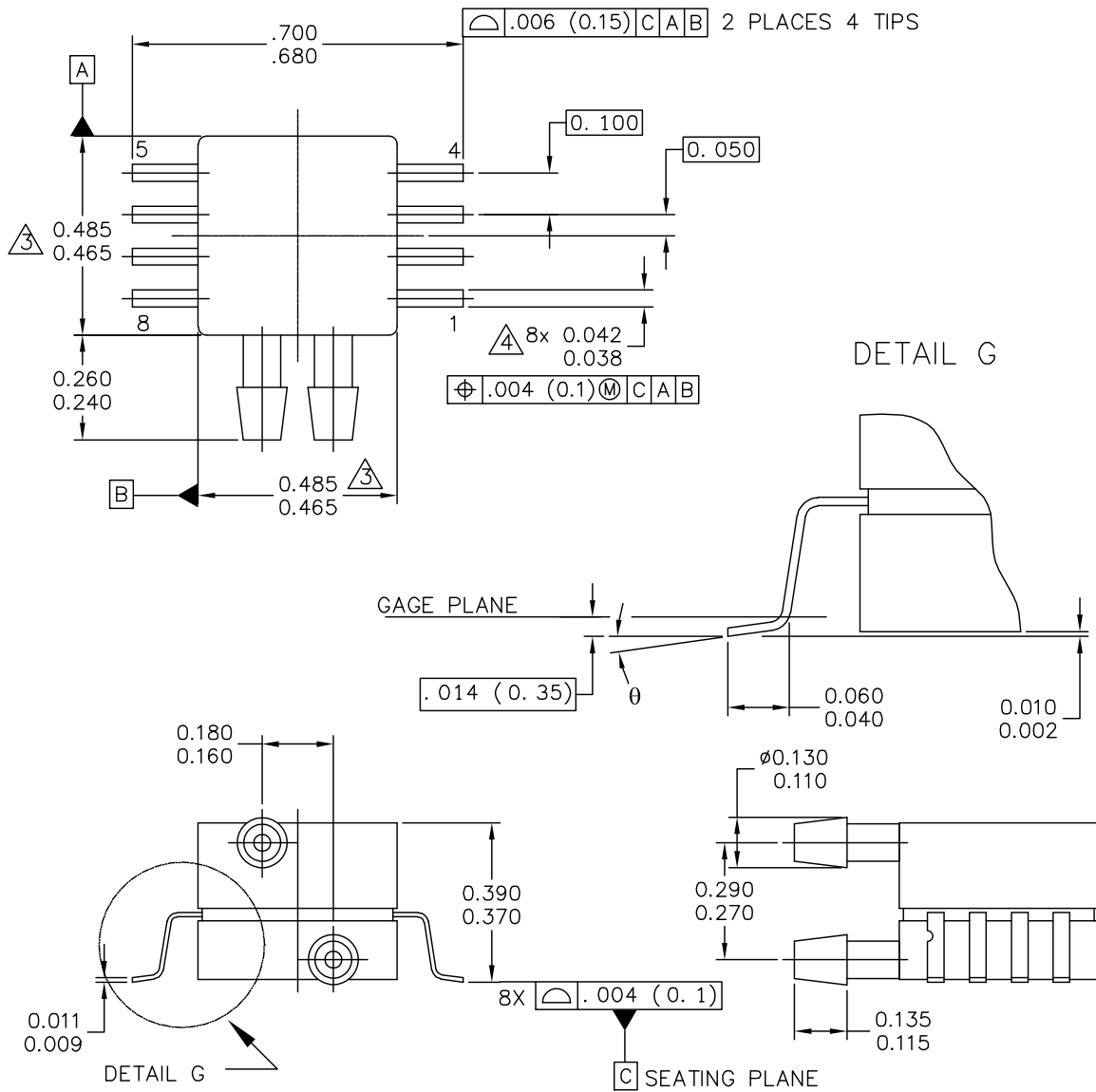

© FREESCALE SEMICONDUCTOR, INC. ALL RIGHTS RESERVED.	MECHANICAL OUTLINE	PRINT VERSION NOT TO SCALE
TITLE: 8 LD SNSR, DUAL PORT	DOCUMENT NO: 98ASA99255D	REV: A
	CASE NUMBER: 1351-01	27 JUL 2005
	STANDARD: NON-JEDEC	

PACKAGE DIMENSIONS

NOTES:

1. CONTROLLING DIMENSION: INCH
2. INTERPRET DIMENSIONS AND TOLERANCES PER ASME Y14.5M-1994.
3. DIMENSIONS DO NOT INCLUDE MOLD FLASH OR PROTRUSIONS.
MOLD FLASH AND PROTRUSIONS SHALL NOT EXCEED .006 PER SIDE.
4. DIMENSION DOES NOT INCLUDE DAMBAR PROTRUSION. ALLOWABLE DAMBAR PROTRUSION SHALL BE .008 MAXIMUM.

STYLE 1:

PIN 1: GND
 PIN 2: +Vout
 PIN 3: Vs
 PIN 4: -Vout
 PIN 5: N/C
 PIN 6: N/C
 PIN 7: N/C
 PIN 8: N/C

STYLE 2:

PIN 1: N/C
 PIN 2: Vs
 PIN 3: GND
 PIN 4: Vout
 PIN 5: N/C
 PIN 6: N/C
 PIN 7: N/C
 PIN 8: N/C

© FREESCALE SEMICONDUCTOR, INC. ALL RIGHTS RESERVED.	MECHANICAL OUTLINE	PRINT VERSION NOT TO SCALE	
TITLE: 8 LD SNSR, DUAL PORT	DOCUMENT NO: 98ASA99255D	REV: A	
	CASE NUMBER: 1351-01	27 JUL 2005	
	STANDARD: NON-JEDEC		

PAGE 2 OF 2

CASE 1351-01
ISSUE A
SMALL OUTLINE PACKAGE

PACKAGE DIMENSIONS

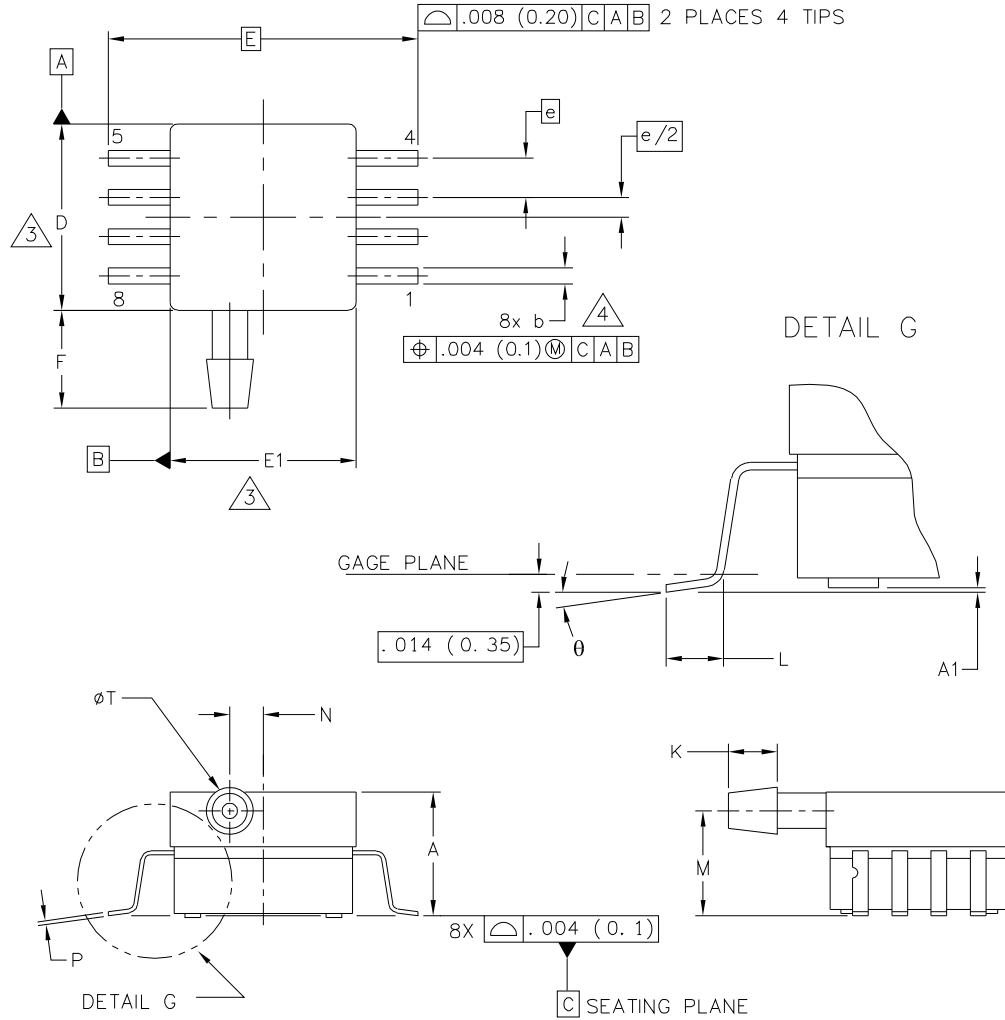

© FREESCALE SEMICONDUCTOR, INC. ALL RIGHTS RESERVED.	MECHANICAL OUTLINE	PRINT VERSION NOT TO SCALE
TITLE: 8 LD SOP, SIDE PORT	DOCUMENT NO: 98ASA99303D	REV: D
	CASE NUMBER: 1369-01	13 DEC 2010
	STANDARD: NON-JEDEC	

**CASE 1369-01
ISSUE D
SMALL OUTLINE PACKAGE**

PACKAGE DIMENSIONS

NOTES:

1. CONTROLLING DIMENSION: INCH
2. INTERPRET DIMENSIONS AND TOLERANCES PER ASME Y14.5M-1994.
3. DIMENSIONS DO NOT INCLUDE MOLD FLASH OR PROTRUSIONS.
MOLD FLASH AND PROTRUSIONS SHALL NOT EXCEED .006 (0.152) PER SIDE.
4. DIMENSION DOES NOT INCLUDE DAMBAR PROTRUSION. ALLOWABLE DAMBAR PROTRUSION SHALL BE .008 (0.203) MAXIMUM.

DIM	INCHES		MILLIMETERS		DIM	INCHES		MILLIMETERS	
	MIN	MAX	MIN	MAX		MIN	MAX	MIN	MAX
A	.300	.330	7.62	8.38	Ø	0'	7'	0'	7'
A1	.002	.010	0.05	0.25	-	----	----	----	----
b	.038	.042	0.96	1.07	-	----	----	----	----
D	.465	.485	11.81	12.32	-	----	----	----	----
E	.717 BSC		18.21 BSC		-	----	----	----	----
E1	.465	.485	11.81	12.32	-	----	----	----	----
e	.100 BSC		2.54 BSC		-	----	----	----	----
F	.245	.255	6.22	6.47	-	----	----	----	----
K	.120	.130	3.05	3.30	-	----	----	----	----
L	.061	.071	1.55	1.80	-	----	----	----	----
M	.270	.290	6.86	7.36	-	----	----	----	----
N	.080	.090	2.03	2.28	-	----	----	----	----
P	.009	.011	0.23	0.28	-	----	----	----	----
T	.115	.125	2.92	3.17	-	----	----	----	----
© FREESCALE SEMICONDUCTOR, INC. ALL RIGHTS RESERVED.			MECHANICAL OUTLINE			PRINT VERSION NOT TO SCALE			
TITLE: 8 LD SOP, SIDE PORT					DOCUMENT NO: 98ASA99303D			REV: D	
					CASE NUMBER: 1369-01			13 DEC 2010	
					STANDARD: NON-JEDEC				

PAGE 2 OF 2

**CASE 1369-01
ISSUE D
SMALL OUTLINE PACKAGE**

PACKAGE DIMENSIONS

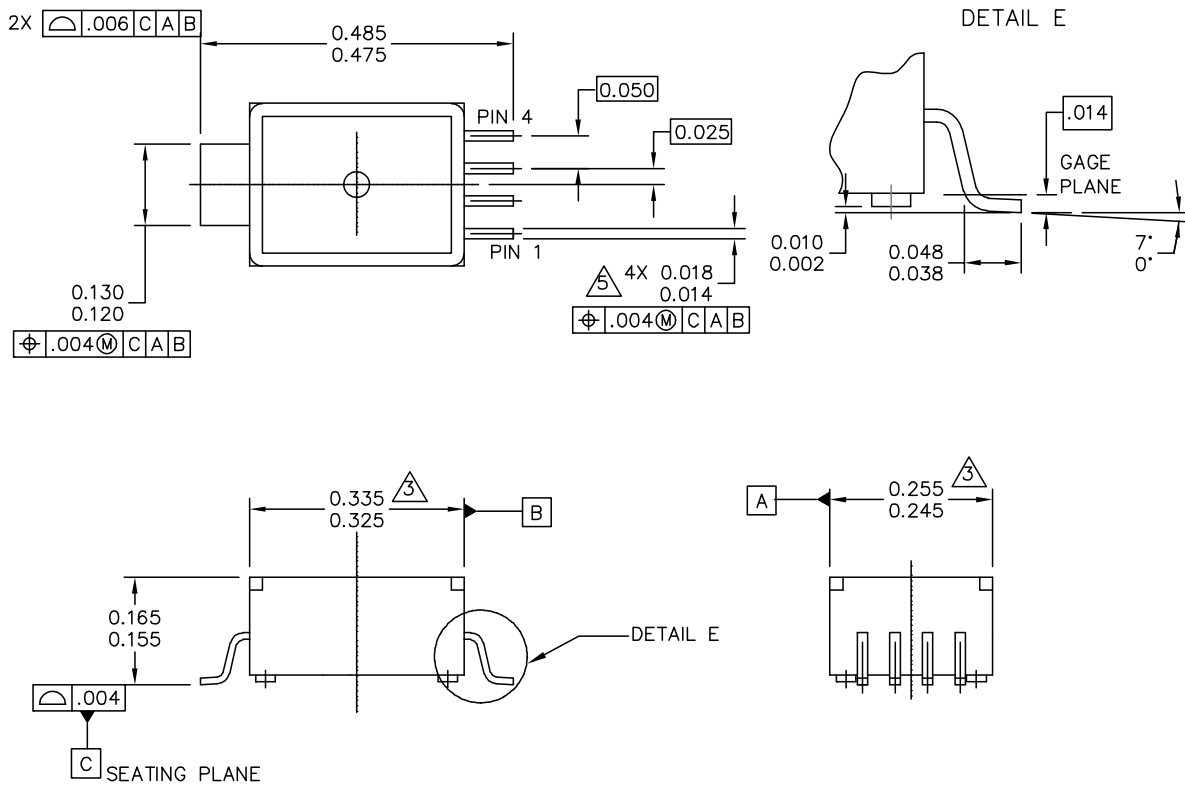

© FREESCALE SEMICONDUCTOR, INC. ALL RIGHTS RESERVED.		MECHANICAL OUTLINE		PRINT VERSION NOT TO SCALE	
TITLE: 5 LD M-PAC		DOCUMENT NO: 98ARH99088A		REV: B	
		CASE NUMBER: 1320-02		22 JUL 2005	
		STANDARD: NON-JEDEC			

PAGE 1 OF 2

**CASE 1320-02
ISSUE B**

PACKAGE DIMENSIONS

NOTES:

1. DIMENSIONS ARE IN INCHES.
2. INTERPRET DIMENSIONS AND TOLERANCES PER ASME Y14.5M-1994.
3. DIMENSION DOES NOT INCLUDE MOLD FLASH OR PROTRUSION. MOLD FLASH OR PROTRUSION SHALL NOT EXCEED .006" PER SIDE.
4. ALL VERTICAL SURFACES TO BE 5° MAXIMUM.
5. DIMENSION DOES NOT INCLUDE DAMBAR PROTRUSION. ALLOWABLE DAMBAR PROTRUSION SHALL BE .008 MAXIMUM.

PIN 1: GND
 PIN 2: +Vout
 PIN 3: Vs
 PIN 4: -Vout

© FREESCALE SEMICONDUCTOR, INC. ALL RIGHTS RESERVED.	MECHANICAL OUTLINE	PRINT VERSION NOT TO SCALE	
TITLE: <div style="text-align: center; font-size: 1.2em;">5 LD M-PAC</div>	DOCUMENT NO: 98ARH99088A	REV: B	
	CASE NUMBER: 1320-02	22 JUL 2005	
	STANDARD: NON-JEDEC		

PAGE 2 OF 2

**CASE 1320-02
ISSUE B**

PACKAGE DIMENSIONS

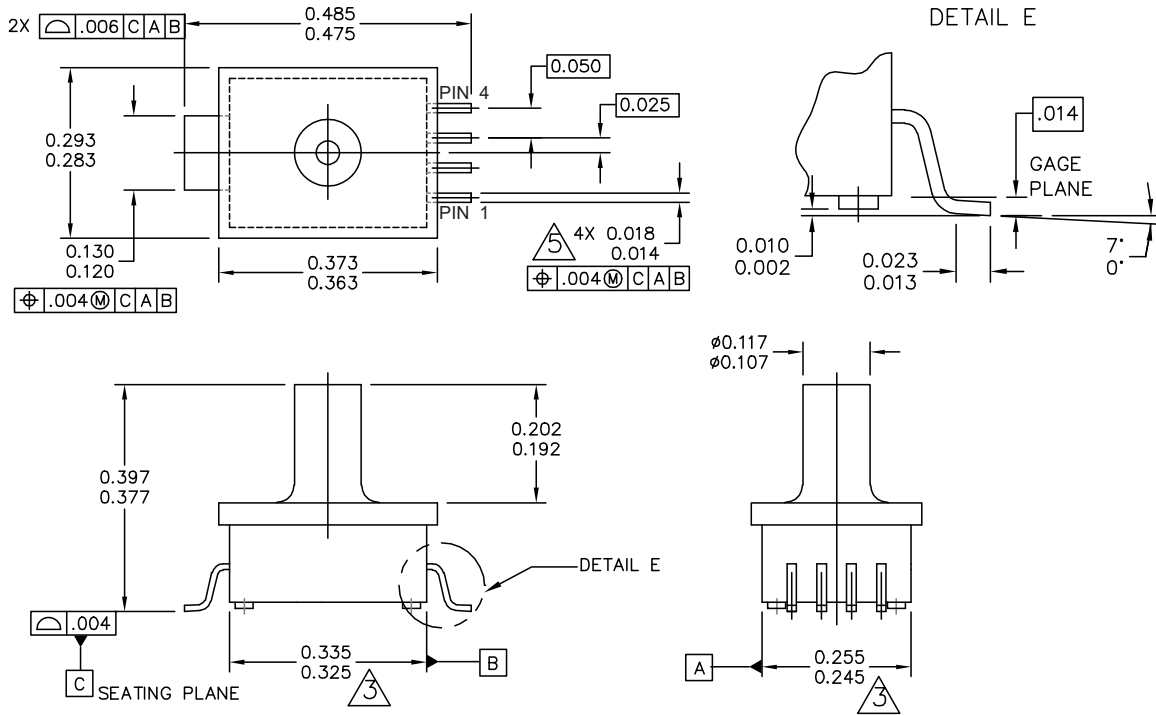

© FREESCALE SEMICONDUCTOR, INC. ALL RIGHTS RESERVED.	MECHANICAL OUTLINE	PRINT VERSION NOT TO SCALE	
TITLE: 5 LD M-PAC, PORTED	DOCUMENT NO: 98ARH99087A	REV: A	
	CASE NUMBER: 1320A-02	22 JUL 2005	
	STANDARD: NON-JEDEC		

**CASE 1320A-02
ISSUE A**

PACKAGE DIMENSIONS

NOTES:

1. DIMENSIONS ARE IN INCHES.

2. INTERPRET DIMENSIONS AND TOLERANCES PER ASME Y14.5M-1994.

3. DIMENSIONS DOES NOT INCLUDE MOLD FLASH OR PROTRUSION. MOLD FLASH OR PROTRUSION SHALL NOT EXCEED .006" PER SIDE.

4. ALL VERTICAL SURFACES TO BE 5" MAXIMUM.

5. DIMENSION DOES NOT INCLUDE DAMBAR PROTRUSION. ALLOWABLE DAMBAR PROTRUSION SHALL BE .008 MAXIMUM.

© FREESCALE SEMICONDUCTOR, INC. ALL RIGHTS RESERVED.	MECHANICAL OUTLINE	PRINT VERSION NOT TO SCALE	
TITLE: 5 LD M-PAC, PORTED	DOCUMENT NO: 98ARH99087A	REV: A	
	CASE NUMBER: 1320A-02	22 JUL 2005	
	STANDARD: NON-JEDEC		

PAGE 2 OF 2

**CASE 1320A-02
ISSUE A**

Table 3. Revision History

Revision number	Revision date	Description of changes
9	10/2012	<ul style="list-style-type: none"> <li data-bbox="435 243 1295 275">• Deleted references to device number MPXV2053GVP throughout the document



How to Reach Us:

Home Page:
freescale.com

Web Support:
freescale.com/support

Information in this document is provided solely to enable system and software implementers to use Freescale products. There are no express or implied copyright licenses granted hereunder to design or fabricate any integrated circuits based on the information in this document.

Freescale reserves the right to make changes without further notice to any products herein. Freescale makes no warranty, representation, or guarantee regarding the suitability of its products for any particular purpose, nor does Freescale assume any liability arising out of the application or use of any product or circuit, and specifically disclaims any and all liability, including without limitation consequential or incidental damages. "Typical" parameters that may be provided in Freescale data sheets and/or specifications can and do vary in different applications, and actual performance may vary over time. All operating parameters, including "typicals," must be validated for each customer application by customer's technical experts. Freescale does not convey any license under its patent rights nor the rights of others. Freescale sells products pursuant to standard terms and conditions of sale, which can be found at the following address: freescale.com/salestermsandconditions.

Freescale, the Freescale logo, Energy Efficient Solutions logo, are trademarks of Freescale Semiconductor, Inc., Reg. U.S. Pat. & Tm. Off. Xtrinsic is a trademark of Freescale Semiconductor, Inc. All other product or service names are the property of their respective owners.

© 2012 Freescale Semiconductor, Inc.