



Chipsmall Limited consists of a professional team with an average of over 10 year of expertise in the distribution of electronic components. Based in Hongkong, we have already established firm and mutual-benefit business relationships with customers from,Europe,America and south Asia,supplying obsolete and hard-to-find components to meet their specific needs.

With the principle of “Quality Parts,Customers Priority,Honest Operation,and Considerate Service”,our business mainly focus on the distribution of electronic components. Line cards we deal with include Microchip,ALPS,ROHM,Xilinx,Pulse,ON,Everlight and Freescale. Main products comprise IC,Modules,Potentiometer,IC Socket,Relay,Connector.Our parts cover such applications as commercial,industrial, and automotives areas.

We are looking forward to setting up business relationship with you and hope to provide you with the best service and solution. Let us make a better world for our industry!



## Contact us

Tel: +86-755-8981 8866 Fax: +86-755-8427 6832

Email & Skype: info@chipsmall.com Web: www.chipsmall.com

Address: A1208, Overseas Decoration Building, #122 Zhenhua RD., Futian, Shenzhen, China



# MPXV7002 Integrated Silicon Pressure Sensor On-Chip Signal Conditioned, Temperature Compensated and Calibrated

The MPXV7002 series piezoresistive transducers are state-of-the-art monolithic silicon pressure sensors designed for a wide range of applications, but particularly those employing a microcontroller or microprocessor with A/D inputs. This transducer combines advanced micromachining techniques, thin-film metallization, and bipolar processing to provide an accurate, high level analog output signal that is proportional to the applied pressure.

## Features

- 2.5% Typical Error over +10°C to +60°C with Auto Zero
- 6.25% Maximum Error over +10°C to +60°C without Auto Zero
- Ideally Suited for Microprocessor or Microcontroller-Based Systems
- Thermoplastic (PPS) Surface Mount Package
- Temperature Compensated over +10° to +60°C
- Patented Silicon Shear Stress Strain Gauge
- Available in Differential and Gauge Configurations

## MPXV7002

-2 to +2 kPa (-0.3 to +0.3 psi)  
0.5 to 4.5 V Output

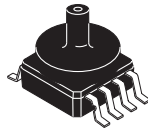

**MPXV7002GC6U/C6T1**  
**CASE 482A**

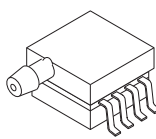

**MPXV7002GP**  
**CASE 1369**

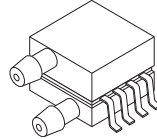

**MPXV7002DP**  
**CASE 1351**

**Small Outline Package**

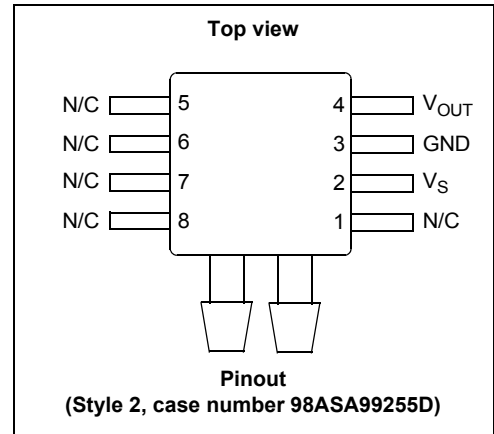

| ORDERING INFORMATION                           |                 |          |            |        |      |               |              |          |                |
|--|-----------------|----------|------------|--------|------|---------------|--------------|----------|----------------|
| Device Name                                    | Package Options | Case No. | # of Ports |        |      | Pressure Type |              |          | Device Marking |
|  |                 |          | None       | Single | Dual | Gauge         | Differential | Absolute |                |
| <b>Small Outline Package (MPXV7002 Series)</b> |                 |          |            |        |      |               |              |          |                |
| MPXV7002GC6U                                   | Rails           | 482A     |            | •      |      | •             |              |          | MPXV7002G      |
| MPXV7002GC6T1                                  | Tape & Reel     | 482A     |            | •      |      | •             |              |          | MPXV7002G      |
| MPXV7002GP                                     | Trays           | 1369     |            | •      |      | •             |              |          | MPXV7002G      |
| MPXV7002DP                                     | Trays           | 1351     |            |        | •    |               | •            |          | MPXV7002DP     |
| MPXV7002DPT1                                   | Tape & Reel     | 1351     |            |        | •    |               | •            |          | MPXV7002DP     |



## Contents

|   |   |    |
|---|---|----|
| 1 | Operating Characteristics   | 3  |
| 2 | Maximum Ratings   | 4  |
| 3 | On-Chip Temperature Compensation, Calibration and Signal Conditioning | 5  |
| 4 | Pressure (P1)/Vacuum (P2) Side Identification Table                   | 6  |
| 5 | Minimum Recommended Footprint for Surface Mounted Applications        | 6  |
| 6 | Package Dimensions  | 7  |
| 7 | Revision History  | 12 |

## Related Documentation

The MPXV7002 device features and operations are described in a variety of reference manuals, user guides, and application notes. To find the most-current versions of these documents:

1. Go to the MPXV7002 web page at <http://www.nxp.com/products/:MPXV7002>.
2. Click the Documentation tab.

### MPXV7002

---

# 1 Operating Characteristics

**Table 1. Operating Characteristics** ( $V_S = 5.0$  Vdc,  $T_A = 25^\circ\text{C}$  unless otherwise noted. Decoupling circuit shown in [Figure 3](#) required to meet specification.)

| Characteristic  | Symbol    | Min  | Typ             | Max        | Unit        |
|---|-----------|------|-----------------|------------|-------------|
| Pressure Range <sup>(1)</sup>                           | $P_{OP}$  | -2.0 | —               | 2.0        | kPa         |
| Supply Voltage <sup>(2)</sup>                           | $V_S$     | 4.75 | 5.0             | 5.25       | Vdc         |
| Supply Current  | $I_o$     | —    | —               | 10         | mAdc        |
| Pressure Offset <sup>(3)</sup><br>@ $V_S = 5.0$ Volts   | $V_{off}$ | 0.25 | 0.5             | 0.75       | Vdc         |
| Full Scale Output <sup>(4)</sup><br>@ $V_S = 5.0$ Volts | $V_{FSO}$ | 4.25 | 4.5             | 4.75       | Vdc         |
| Full Scale Span <sup>(5)</sup><br>@ $V_S = 5.0$ Volts   | $V_{FSS}$ | 3.5  | 4.0             | 4.5 V      | Vdc         |
| Accuracy <sup>(6)</sup>                                 | —         | —    | $\pm 2.5^{(7)}$ | $\pm 6.25$ | % $V_{FSS}$ |
| Sensitivity   | V/P       | —    | 1.0             | —          | V/kPa       |
| Response Time <sup>(8)</sup>                            | $t_R$     | —    | 1.0             | —          | ms          |
| Output Source Current at Full Scale Output              | $I_{O+}$  | —    | 0.1             | —          | mAdc        |
| Warm-Up Time <sup>(9)</sup>                             | —         | —    | 20              | —          | ms          |

1. 1.0 kPa (kiloPascal) equals 0.145 psi.

2. Device is ratiometric within this specified excitation range.

3. Offset ( $V_{off}$ ) is defined as the output voltage at the minimum rated pressure.

4. Full Scale Output ( $V_{FSO}$ ) is defined as the output voltage at the maximum or full rated pressure.

5. Full Scale Span ( $V_{FSS}$ ) is defined as the algebraic difference between the output voltage at full rated pressure and the output voltage at the minimum rated pressure.

6. Accuracy (error budget) consists of the following:

Linearity: Output deviation from a straight line relationship with pressure over the specified pressure range.

Temperature Hysteresis: Output deviation at any temperature within the operating temperature range, after the temperature is cycled to and from the minimum or maximum operating temperature points, with zero differential pressure applied.

Pressure Hysteresis: Output deviation at any pressure within the specified range, when this pressure is cycled to and from the minimum or maximum rated pressure, at  $25^\circ\text{C}$ .

TcSpan: Output deviation over the temperature range of  $10^\circ$  to  $60^\circ\text{C}$ , relative to  $25^\circ\text{C}$ .

TcOffset: Output deviation with minimum rated pressure applied, over the temperature range of  $10^\circ$  to  $60^\circ\text{C}$ , relative to  $25^\circ\text{C}$ .

Variation from Nominal: The variation from nominal values, for Offset or Full Scale Span, as a percent of  $V_{FSS}$ , at  $25^\circ\text{C}$ .

7. Auto Zero at Factory Installation: Due to the sensitivity of the MPXV7002 Series, external mechanical stresses and mounting position can affect the zero pressure output reading. Auto zero is defined as storing the zero pressure output reading and subtracting this from the device's output during normal operations. Reference AN1636 for specific information. The specified accuracy assumes a maximum temperature change of  $\pm 5^\circ\text{C}$  between auto zero and measurement.

8. Response Time is defined as the time for the incremental change in the output to go from 10% to 90% of its final value when subjected to a specified step change in pressure.

9. Warm-up Time is defined as the time required for the product to meet the specified output voltage after the Pressure has been stabilized.

## 2 Maximum Ratings

Table 2. Maximum Ratings<sup>(1)</sup>

| Rating                           | Symbol    | Value       | Unit |
|----------------------------------|-----------|-------------|------|
| Maximum Pressure ( $P_1 > P_2$ ) | $P_{max}$ | 75          | kPa  |
| Storage Temperature              | $T_{stg}$ | -30 to +100 | °C   |
| Operating Temperature            | $T_A$     | 10 to 60    | °C   |

1. Exposure beyond the specified limits may cause permanent damage or degradation to the device.

Figure 1 shows a block diagram of the internal circuitry integrated on a pressure sensor chip.

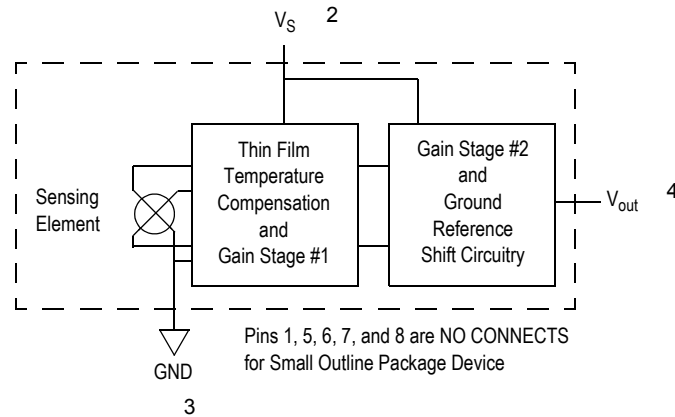

Figure 1. Integrated Pressure Sensor Schematic

### 3 On-Chip Temperature Compensation, Calibration and Signal Conditioning

The performance over temperature is achieved by integrating the shear-stress strain gauge, temperature compensation, calibration and signal conditioning circuitry onto a single monolithic chip.

Figure 2 illustrates the Differential or Gauge configuration in the basic chip carrier (Case 482). A gel die coat isolates the die surface and wire bonds from the environment, while allowing the pressure signal to be transmitted to the sensor diaphragm.

The MPXV7002 series pressure sensor operating characteristics, and internal reliability and qualification tests are based on use of dry air as the pressure media. Media, other than dry air, may have adverse effects on sensor performance and long-term reliability. Contact the factory for information regarding media compatibility in your application.

Figure 3 shows the recommended decoupling circuit for interfacing the integrated sensor to the A/D input of a microprocessor or microcontroller. Proper decoupling of the power supply is recommended.

Figure 4 shows the sensor output signal relative to pressure input. Typical, minimum, and maximum output curves are shown for operation over a temperature range of 10° to 60°C using the decoupling circuit shown in Figure 3. The output will saturate outside of the specified pressure range.

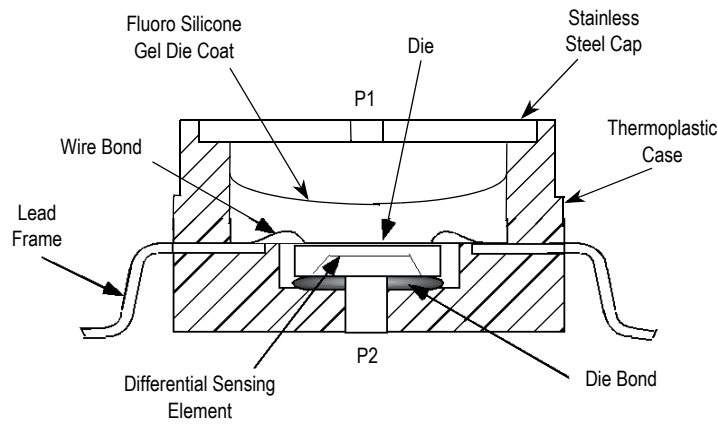

Figure 2. Cross-Sectional Diagram SOP (not to scale)

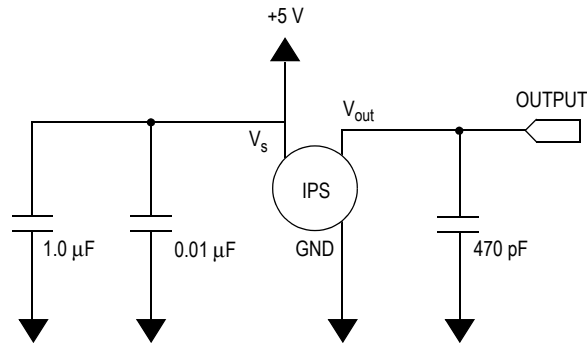

Figure 3. Recommended Power Supply Decoupling and Output Filtering (For additional output filtering, please refer to Application Note AN1646.)

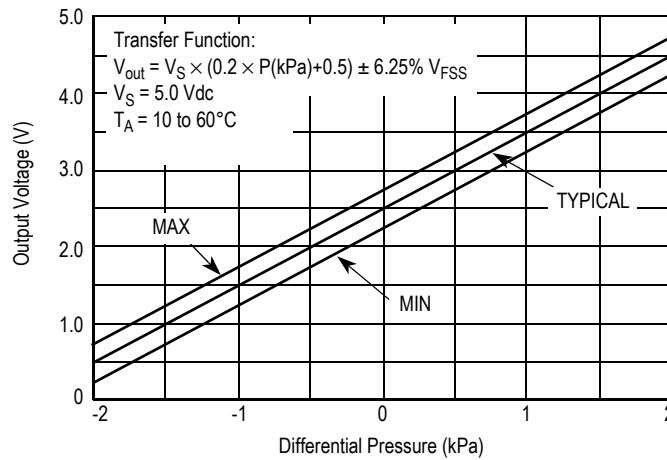

Figure 4. Output versus Pressure Differential

#### 4 Pressure (P1)/Vacuum (P2) Side Identification Table

NXP designates the two sides of the pressure sensor as the Pressure (P1) side and the Vacuum (P2) side. The Pressure (P1) side is the side containing a gel die coat which protects the die from harsh media.

The Pressure (P1) side may be identified by using the following table:

| Part Number        | Case Type | Pressure (P1) Side Identifier |
|--------------------|-----------|-------------------------------|
| MPXV7002GC6U/GC6T1 | 482A-01   | Side with Port Attached       |
| MPXV7002GP         | 1369-01   | Side with Port Attached       |
| MPXV7002DP         | 1351-01   | Side with Part Marking        |

#### 5 Minimum Recommended Footprint for Surface Mounted Applications

Surface mount board layout is a critical portion of the total design. The footprint for the surface mount packages must be the correct size to ensure proper solder connection interface between the board and the package. With the correct footprint, the packages will self align when subjected to a solder reflow process. It is always recommended to design boards with a solder mask layer to avoid bridging and shorting between solder pads.

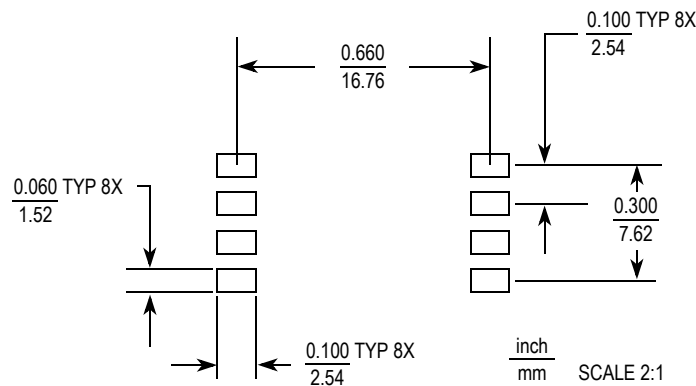
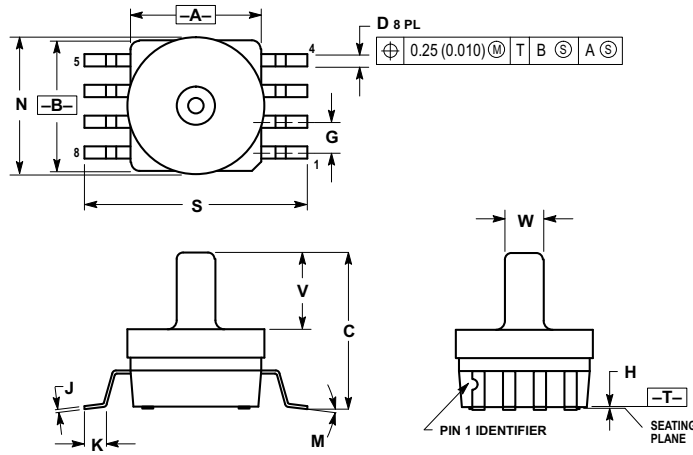

Figure 5. Small Outline Package Footprint

# 6 Package Dimensions



- NOTES:
1. DIMENSIONING AND TOLERANCING PER ANSI Y14.5M, 1982.
  2. CONTROLLING DIMENSION: INCH.
  3. DIMENSION A AND B DO NOT INCLUDE MOLD PROTRUSION.
  4. MAXIMUM MOLD PROTRUSION 0.15 (0.006).
  5. ALL VERTICAL SURFACES 5° TYPICAL DRAFT.

| DIM | INCHES    |       | MILLIMETERS |       |
|-----|-----------|-------|-------------|-------|
|     | MIN       | MAX   | MIN         | MAX   |
| A   | 0.415     | 0.425 | 10.54       | 10.79 |
| B   | 0.415     | 0.425 | 10.54       | 10.79 |
| C   | 0.500     | 0.520 | 12.70       | 13.21 |
| D   | 0.038     | 0.042 | 0.96        | 1.07  |
| G   | 0.100 BSC |       | 2.54 BSC    |       |
| H   | 0.002     | 0.010 | 0.05        | 0.25  |
| J   | 0.009     | 0.011 | 0.23        | 0.28  |
| K   | 0.061     | 0.071 | 1.55        | 1.80  |
| M   | 0°        | 7°    | 0°          | 7°    |
| N   | 0.444     | 0.448 | 11.28       | 11.38 |
| S   | 0.709     | 0.725 | 18.01       | 18.41 |
| V   | 0.245     | 0.255 | 6.22        | 6.48  |
| W   | 0.115     | 0.125 | 2.92        | 3.17  |

CASE 482A-01  
 ISSUE A

DATE 05/13/98

CASE 482A-01  
 ISSUE A  
 SMALL OUTLINE PACKAGE



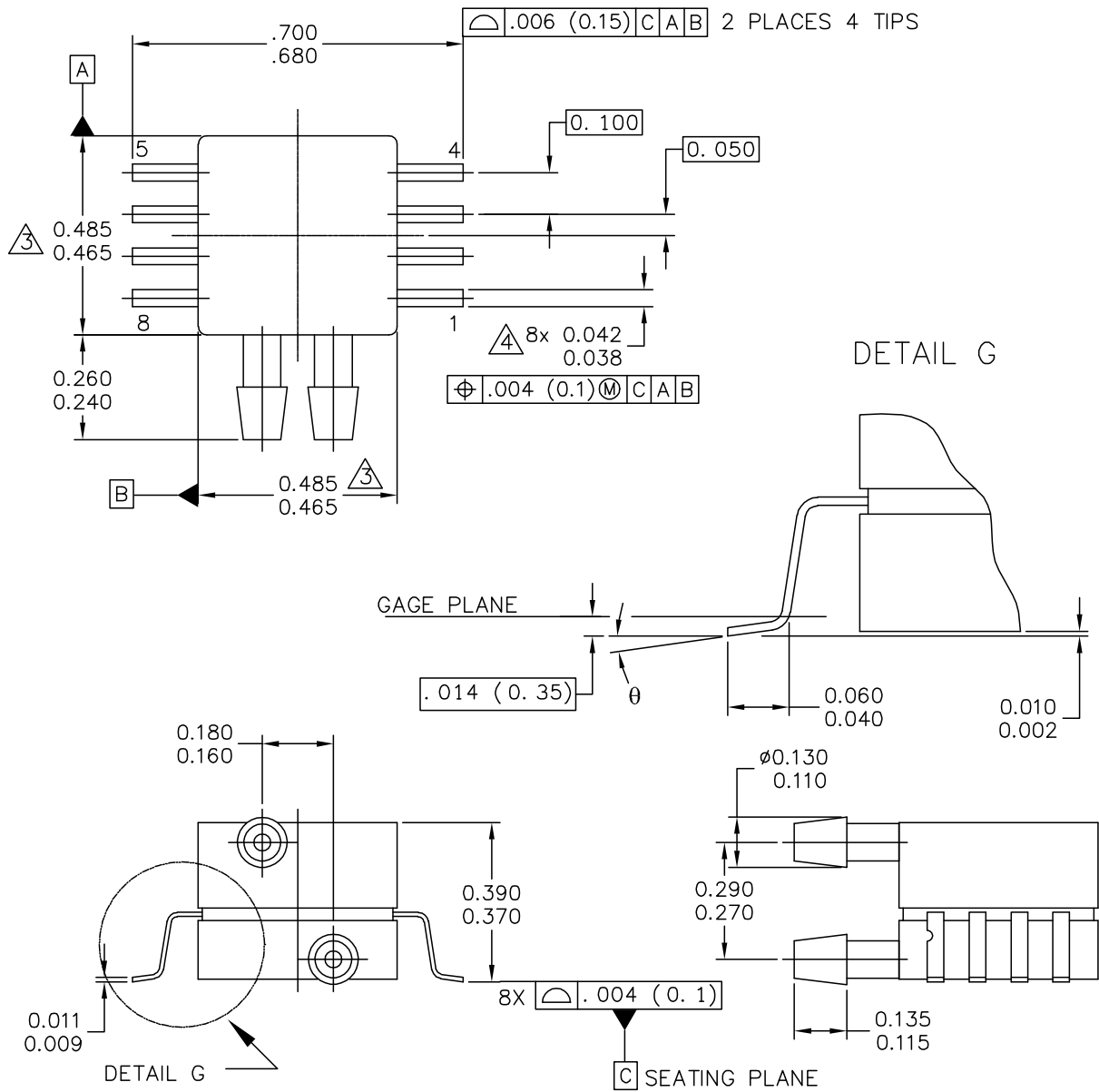

|   |                          |                            |
|---|--------------------------|----------------------------|
| © NXP SEMICONDUCTORS N. V.<br>ALL RIGHTS RESERVED | MECHANICAL OUTLINE       | PRINT VERSION NOT TO SCALE |
| TITLE:  | DOCUMENT NO: 98ASA99255D | REV: B                     |
| 8 LD SNSR, DUAL PORT                              | STANDARD: NON-JEDEC      |                            |
|   | SOT1693-1                | 14 MAR 2016                |

**CASE 1351-01  
ISSUE A  
SMALL OUTLINE PACKAGE**



NOTES:

1. CONTROLLING DIMENSION: INCH
2. INTERPRET DIMENSIONS AND TOLERANCES PER ASME Y14.5M-1994.

3. DIMENSIONS DO NOT INCLUDE MOLD FLASH OR PROTRUSIONS.  
MOLD FLASH AND PROTRUSIONS SHALL NOT EXCEED .006 PER SIDE.

4. DIMENSION DOES NOT INCLUDE DAMBAR PROTRUSION. ALLOWABLE DAMBAR  
PROTRUSION SHALL BE .008 MAXIMUM.

STYLE 1:

PIN 1: GND  
PIN 2: +Vout  
PIN 3: Vs  
PIN 4: -Vout  
PIN 5: N/C  
PIN 6: N/C  
PIN 7: N/C  
PIN 8: N/C

STYLE 2:

PIN 1: N/C  
PIN 2: Vs  
PIN 3: GND  
PIN 4: Vout  
PIN 5: N/C  
PIN 6: N/C  
PIN 7: N/C  
PIN 8: N/C

|   |                          |                            |
|---|--------------------------|----------------------------|
| © NXP SEMICONDUCTORS N. V.<br>ALL RIGHTS RESERVED | MECHANICAL OUTLINE       | PRINT VERSION NOT TO SCALE |
| TITLE:  | DOCUMENT NO: 98ASA99255D | REV: B                     |
| 8 LD SNSR, DUAL PORT                              | STANDARD: NON-JEDEC      |                            |
|   | SOT1693-1                | 14 MAR 2016                |

**CASE 1351-01  
ISSUE A  
SMALL OUTLINE PACKAGE**

**MPXV7002**

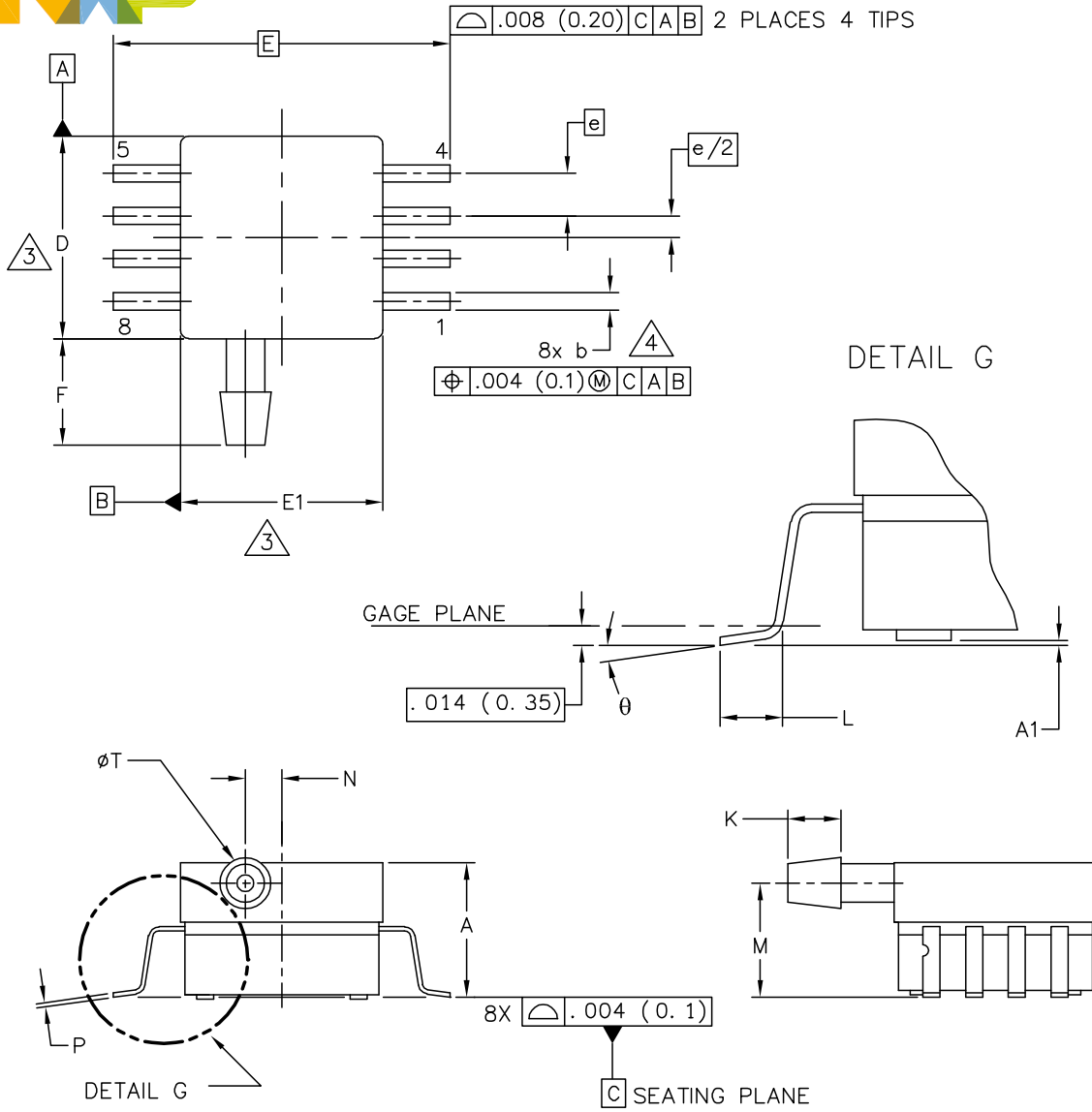

|   |                          |                            |
|---|--------------------------|----------------------------|
| © NXP SEMICONDUCTORS N. V.<br>ALL RIGHTS RESERVED | MECHANICAL OUTLINE       | PRINT VERSION NOT TO SCALE |
| TITLE:<br><br>8 LD SOP, SIDE PORT                 | DOCUMENT NO: 98ASA99303D | REV: E                     |
|   | STANDARD: NON-JEDEC      |                            |
|   | SOT1693-3                | 14 MAR 2016                |

**CASE 1369-01  
ISSUE B  
SMALL OUTLINE PACKAGE**



NOTES:

1. CONTROLLING DIMENSION: INCH
2. INTERPRET DIMENSIONS AND TOLERANCES PER ASME Y14.5M-1994.
3. DIMENSIONS DO NOT INCLUDE MOLD FLASH OR PROTRUSIONS.  
MOLD FLASH AND PROTRUSIONS SHALL NOT EXCEED .006 (0.152) PER SIDE.
4. DIMENSION DOES NOT INCLUDE DAMBAR PROTRUSION. ALLOWABLE DAMBAR PROTRUSION SHALL BE .008 (0.203) MAXIMUM.

| DIM   | INCHES   |      | MILLIMETERS        |       | DIM                                  | INCHES                     |             | MILLIMETERS |      |
|---|----------|------|--------------------|-------|--------------------------------------|----------------------------|-------------|-------------|------|
|   | MIN      | MAX  | MIN                | MAX   |                                      | MIN                        | MAX         | MIN         | MAX  |
| A   | .300     | .330 | 7.62               | 8.38  | θ                                    | 0°                         | 7°          | 0°          | 7°   |
| A1  | .002     | .010 | 0.05               | 0.25  | -                                    | ----                       | ----        | ----        | ---- |
| b   | .038     | .042 | 0.96               | 1.07  | -                                    | ----                       | ----        | ----        | ---- |
| D   | .465     | .485 | 11.81              | 12.32 | -                                    | ----                       | ----        | ----        | ---- |
| E   | .717 BSC |      | 18.21 BSC          |       | -                                    | ----                       | ----        | ----        | ---- |
| E1  | .465     | .485 | 11.81              | 12.32 | -                                    | ----                       | ----        | ----        | ---- |
| e   | .100 BSC |      | 2.54 BSC           |       | -                                    | ----                       | ----        | ----        | ---- |
| F   | .245     | .255 | 6.22               | 6.47  | -                                    | ----                       | ----        | ----        | ---- |
| K   | .120     | .130 | 3.05               | 3.30  | -                                    | ----                       | ----        | ----        | ---- |
| L   | .061     | .071 | 1.55               | 1.80  | -                                    | ----                       | ----        | ----        | ---- |
| M   | .270     | .290 | 6.86               | 7.36  | -                                    | ----                       | ----        | ----        | ---- |
| N   | .080     | .090 | 2.03               | 2.28  | -                                    | ----                       | ----        | ----        | ---- |
| P   | .009     | .011 | 0.23               | 0.28  | -                                    | ----                       | ----        | ----        | ---- |
| T   | .115     | .125 | 2.92               | 3.17  | -                                    | ----                       | ----        | ----        | ---- |
| © NXP SEMICONDUCTORS N. V.<br>ALL RIGHTS RESERVED |          |      | MECHANICAL OUTLINE |       |                                      | PRINT VERSION NOT TO SCALE |             |             |      |
| TITLE:  |          |      |                    |       | DOCUMENT NO: 98ASA99303D      REV: E |                            |             |             |      |
| 8 LD SOP, SIDE PORT                               |          |      |                    |       | STANDARD: NON-JEDEC                  |                            |             |             |      |
|   |          |      |                    |       | SOT1693-3                            |                            | 14 MAR 2016 |             |      |

**CASE 1369-01  
ISSUE B  
SMALL OUTLINE PACKAGE**

## 7 Revision History

Table 1. Revision History

| Document ID       | Release Date   | Data sheet status | Change notice | Supersedes        |
|-------------------|--|-------------------|---------------|-------------------|
| MPXV7002 Rev. 4   | 2017 March   | Technical data    | —             | MPXV7002 Rev. 3.0 |
| Modifications     | <ul style="list-style-type: none"><li>• Added MPXV7002DPT1 to the <a href="#">Ordering Information table on page 1</a>.</li><li>• Updated Pressure offset min, typ, max values from 2.25, 2.5 and 2.75 to 0.25, 0.5 and 0.75 respectively in <a href="#">Table 1 on page 3</a>.</li><li>• The format of this data sheet has been redesigned to comply with current identity guidelines of NXP Semiconductors. Legal texts have been adapted to the new company name where appropriate.</li><li>• Updated package outlines 98ASA99303D and 98ASA99255D in <a href="#">Section 6, "Package Dimensions"</a> to comply with current identity guidelines of NXP Semiconductors.</li></ul> |                   |               |                   |
| MPXV7002 Rev. 3.0 | 2015 January   | Technical data    | —             | MPXV7002 Rev. 2.0 |
| MPXV7002 Rev. 2.0 | 2009 January   | Technical data    | —             | MPXV7002 Rev. 1.0 |
| MPXV7002 Rev. 1.0 | 2008 September   | Technical data    | —             | MPXV7002 Rev. 0   |
| MPXV7002 Rev. 0   | 2005 September   | Technical data    | —             | —                 |

---

**How to Reach Us:**

**Home Page:**

[NXP.com](http://www.nxp.com)

**Web Support:**

<http://www.nxp.com/support>

Information in this document is provided solely to enable system and software implementers to use NXP products. There are no expressed or implied copyright licenses granted hereunder to design or fabricate any integrated circuits based on the information in this document. NXP reserves the right to make changes without further notice to any products herein.

NXP makes no warranty, representation, or guarantee regarding the suitability of its products for any particular purpose, nor does NXP assume any liability arising out of the application or use of any product or circuit, and specifically disclaims any and all liability, including without limitation, consequential or incidental damages. "Typical" parameters that may be provided in NXP data sheets and/or specifications can and do vary in different applications, and actual performance may vary over time. All operating parameters, including "typicals," must be validated for each customer application by the customer's technical experts. NXP does not convey any license under its patent rights nor the rights of others. NXP sells products pursuant to standard terms and conditions of sale, which can be found at the following address:

<http://www.nxp.com/terms-of-use.html>.

NXP, the NXP logo, Freescale, the Freescale logo, and the Energy Efficient Solutions logo are trademarks of NXP B.V. All other product or service names are the property of their respective owners. All rights reserved.

© NXP B.V. 2017. All rights reserved.

