



Chipsmall Limited consists of a professional team with an average of over 10 year of expertise in the distribution of electronic components. Based in Hongkong, we have already established firm and mutual-benefit business relationships with customers from,Europe,America and south Asia,supplying obsolete and hard-to-find components to meet their specific needs.

With the principle of “Quality Parts,Customers Priority,Honest Operation,and Considerate Service”,our business mainly focus on the distribution of electronic components. Line cards we deal with include Microchip,ALPS,ROHM,Xilinx,Pulse,ON,Everlight and Freescale. Main products comprise IC,Modules,Potentiometer,IC Socket,Relay,Connector.Our parts cover such applications as commercial,industrial, and automotives areas.

We are looking forward to setting up business relationship with you and hope to provide you with the best service and solution. Let us make a better world for our industry!



Contact us

Tel: +86-755-8981 8866 Fax: +86-755-8427 6832

Email & Skype: info@chipsmall.com Web: www.chipsmall.com

Address: A1208, Overseas Decoration Building, #122 Zhenhua RD., Futian, Shenzhen, China





MRF24J40MA

Data Sheet

2.4 GHz IEEE Std. 802.15.4™
RF Transceiver Module

Note the following details of the code protection feature on Microchip devices:

- Microchip products meet the specification contained in their particular Microchip Data Sheet.
- Microchip believes that its family of products is one of the most secure families of its kind on the market today, when used in the intended manner and under normal conditions.
- There are dishonest and possibly illegal methods used to breach the code protection feature. All of these methods, to our knowledge, require using the Microchip products in a manner outside the operating specifications contained in Microchip's Data Sheets. Most likely, the person doing so is engaged in theft of intellectual property.
- Microchip is willing to work with the customer who is concerned about the integrity of their code.
- Neither Microchip nor any other semiconductor manufacturer can guarantee the security of their code. Code protection does not mean that we are guaranteeing the product as "unbreakable."

Code protection is constantly evolving. We at Microchip are committed to continuously improving the code protection features of our products. Attempts to break Microchip's code protection feature may be a violation of the Digital Millennium Copyright Act. If such acts allow unauthorized access to your software or other copyrighted work, you may have a right to sue for relief under that Act.

Information contained in this publication regarding device applications and the like is provided only for your convenience and may be superseded by updates. It is your responsibility to ensure that your application meets with your specifications. MICROCHIP MAKES NO REPRESENTATIONS OR WARRANTIES OF ANY KIND WHETHER EXPRESS OR IMPLIED, WRITTEN OR ORAL, STATUTORY OR OTHERWISE, RELATED TO THE INFORMATION, INCLUDING BUT NOT LIMITED TO ITS CONDITION, QUALITY, PERFORMANCE, MERCHANTABILITY OR FITNESS FOR PURPOSE. Microchip disclaims all liability arising from this information and its use. Use of Microchip devices in life support and/or safety applications is entirely at the buyer's risk, and the buyer agrees to defend, indemnify and hold harmless Microchip from any and all damages, claims, suits, or expenses resulting from such use. No licenses are conveyed, implicitly or otherwise, under any Microchip intellectual property rights.

Trademarks

The Microchip name and logo, the Microchip logo, Accuron, dsPIC, KEELOQ, KEELOQ logo, MPLAB, PIC, PICmicro, PICSTART, rPIC, SmartShunt and UNI/O are registered trademarks of Microchip Technology Incorporated in the U.S.A. and other countries.

FilterLab, Linear Active Thermistor, MXDEV, MXLAB, SEEVAL, SmartSensor and The Embedded Control Solutions Company are registered trademarks of Microchip Technology Incorporated in the U.S.A.

Analog-for-the-Digital Age, Application Maestro, CodeGuard, dsPICDEM, dsPICDEM.net, dsPICworks, dsSPEAK, ECAN, ECONOMONITOR, FanSense, In-Circuit Serial Programming, ICSP, ICEPIC, Mindi, MiWi, MPASM, MPLAB Certified logo, MPLIB, MPLINK, mTouch, PICkit, PICDEM, PICDEM.net, PICtail, PIC³² logo, PowerCal, PowerInfo, PowerMate, PowerTool, REAL ICE, rLAB, Select Mode, Total Endurance, WiperLock and ZENA are trademarks of Microchip Technology Incorporated in the U.S.A. and other countries.

SQTP is a service mark of Microchip Technology Incorporated in the U.S.A.

All other trademarks mentioned herein are property of their respective companies.

© 2008, Microchip Technology Incorporated, Printed in the U.S.A., All Rights Reserved.

 Printed on recycled paper.

QUALITY MANAGEMENT SYSTEM
CERTIFIED BY DNV
== ISO/TS 16949:2002 ==

Microchip received ISO/TS-16949:2002 certification for its worldwide headquarters, design and wafer fabrication facilities in Chandler and Tempe, Arizona; Gresham, Oregon and design centers in California and India. The Company's quality system processes and procedures are for its PIC[®] MCUs and dsPIC[®] DSCs, KEELOQ[®] code hopping devices, Serial EEPROMs, microperipherals, nonvolatile memory and analog products. In addition, Microchip's quality system for the design and manufacture of development systems is ISO 9001:2000 certified.

2.4 GHz IEEE Std. 802.15.4™ RF Transceiver Module

Features:

- IEEE Std. 802.15.4™ Compliant RF Transceiver
- Supports ZigBee®, MiWi™, MiWi™ P2P and Proprietary Wireless Networking Protocols
- Small Size: 0.7" x 1.1" (17.8 mm x 27.9 mm), Surface Mountable
- Integrated Crystal, Internal Voltage Regulator, Matching Circuitry and PCB Antenna
- Easy Integration into Final Product – Minimize Product Development, Quicker Time to Market
- Radio Regulation Certification for United States (FCC), Canada (IC) and Europe (ETSI)
- Compatible with Microchip Microcontroller Families (PIC16F, PIC18F, PIC24F/H, dsPIC33 and PIC32)
- Up to 400 ft. Range

Operational:

- Operating Voltage: 2.4-3.6V (3.3V typical)
- Temperature Range: -40°C to +85°C Industrial
- Simple, Four-Wire SPI Interface
- Low-Current Consumption:
 - RX mode: 19 mA (typical)
 - TX mode: 23 mA (typical)
 - Sleep: 2 µA (typical)

RF/Analog Features:

- ISM Band 2.405-2.48 GHz Operation
- Data Rate: 250 kbps
- -94 dBm Typical Sensitivity with +5 dBm Maximum Input Level
- +0 dBm Typical Output Power with 36 dB TX Power Control Range
- Integrated Low Phase Noise VCO, Frequency Synthesizer and PLL Loop Filter
- Digital VCO and Filter Calibration
- Integrated RSSI ADC and I/Q DACs
- Integrated LDO
- High Receiver and RSSI Dynamic Range

MAC/Baseband Features:

- Hardware CSMA-CA Mechanism, Automatic ACK Response and FCS Check
- Independent Beacon, Transmit and GTS FIFO
- Supports all CCA modes and RSS/LQI
- Automatic Packet Retransmit Capable
- Hardware Security Engine (AES-128) with CTR, CCM and CBC-MAC modes
- Supports Encryption and Decryption for MAC Sublayer and Upper Layer

FIGURE 1: PIN DIAGRAM

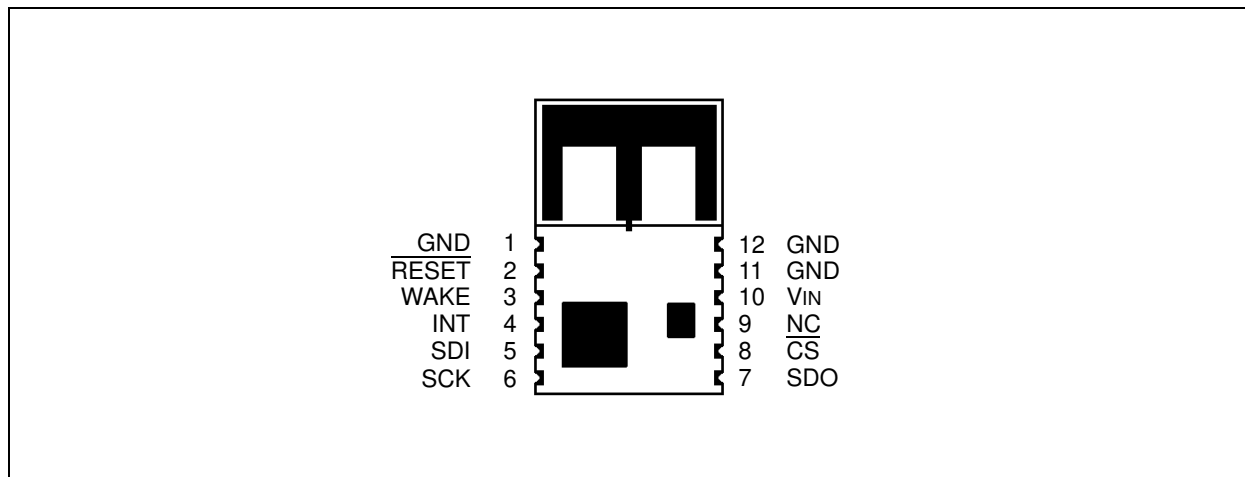

MRF24J40MA

Table of Contents

1.0 Device Overview	3
2.0 Circuit Description	7
3.0 Regulatory Approval.....	15
4.0 Electrical Characteristics	19
Appendix A: Revision History.....	21
Index	23
The Microchip Web Site.....	25
Customer Change Notification Service	25
Customer Support	25
Reader Response	26
Product Identification System.....	27

TO OUR VALUED CUSTOMERS

It is our intention to provide our valued customers with the best documentation possible to ensure successful use of your Microchip products. To this end, we will continue to improve our publications to better suit your needs. Our publications will be refined and enhanced as new volumes and updates are introduced.

If you have any questions or comments regarding this publication, please contact the Marketing Communications Department via E-mail at docerrors@microchip.com or fax the **Reader Response Form** in the back of this data sheet to (480) 792-4150. We welcome your feedback.

Most Current Data Sheet

To obtain the most up-to-date version of this data sheet, please register at our Worldwide Web site at:

<http://www.microchip.com>

You can determine the version of a data sheet by examining its literature number found on the bottom outside corner of any page. The last character of the literature number is the version number, (e.g., DS30000A is version A of document DS30000).

Errata

An errata sheet, describing minor operational differences from the data sheet and recommended workarounds, may exist for current devices. As device/documentation issues become known to us, we will publish an errata sheet. The errata will specify the revision of silicon and revision of document to which it applies.

To determine if an errata sheet exists for a particular device, please check with one of the following:

- Microchip's Worldwide Web site; <http://www.microchip.com>
- Your local Microchip sales office (see last page)

When contacting a sales office, please specify which device, revision of silicon and data sheet (include literature number) you are using.

Customer Notification System

Register on our web site at www.microchip.com to receive the most current information on all of our products.

1.0 DEVICE OVERVIEW

The MRF24J40MA is a 2.4 GHz IEEE Std. 802.15.4™ compliant, surface mount module with integrated crystal, internal voltage regulator, matching circuitry and PCB antenna. The MRF24J40MA module operates in the non-licensed 2.4 GHz frequency band and is FCC, IC and ETSI compliant. The integrated module design frees the integrator from extensive RF and antenna design, and regulatory compliance testing, allowing quicker time to market.

The MRF24J40MA module is compatible with Microchip's ZigBee®, MiWi™ and MiWi P2P software stacks. Each software stack is available as a free download, including source code, from the Microchip web site <http://www.microchip.com/wireless>.

The MRF24J40MA module has received regulatory approvals for modular devices in the United States (FCC), Canada (IC) and Europe (ETSI). Modular approval removes the need for expensive RF and antenna design and allows the end user to place the

MRF24J40MA module inside a finished product and not require regulatory testing for an intentional radiator (RF transmitter). See **Section 3.0 “Regulatory Approval”** for specific requirements to be followed by the integrator.

1.1 Interface Description

Figure 1-1 shows a simplified block diagram of the MRF24J40MA module. The module is based on the Microchip Technology MRF24J40 IEEE 802.15.4™ 2.4 GHz RF Transceiver IC. The module interfaces to many popular Microchip PIC® microcontrollers via a 4-wire serial SPI interface, interrupt, wake, Reset, power and ground, as shown in Figure 1-2. Table 1-1 provides the pin descriptions.

Data communications with the MRF24J40MA module are documented in the “*MRF24J40 IEEE 802.15.4™ 2.4 GHz RF Transceiver Data Sheet*” (DS39776). Refer to the MRF24J40 Data Sheet for specific serial interface protocol and register definitions.

FIGURE 1-1: MRF24J40MA BLOCK DIAGRAM

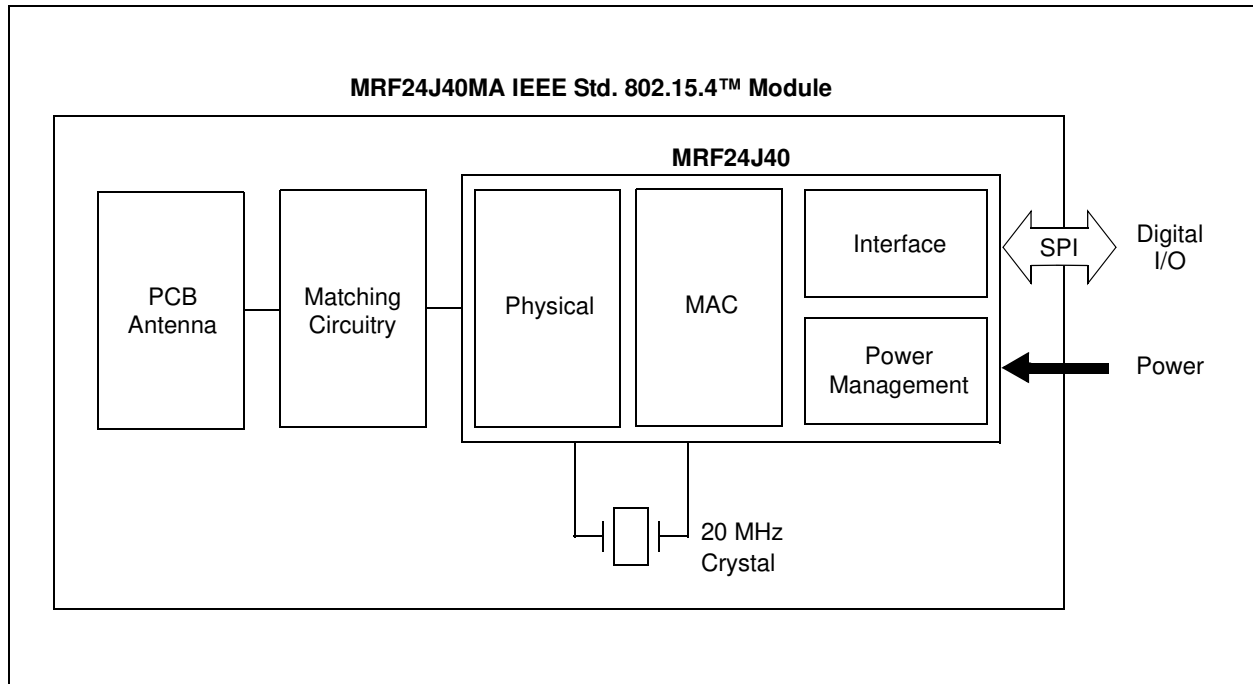

MRF24J40MA

TABLE 1-1: PIN DESCRIPTION

Pin	Symbol	Type	Description
1	GND	Power	Ground
2	$\overline{\text{RESET}}$	DI	Global hardware Reset pin
3	WAKE	DI	External wake-up trigger
4	INT	DO	Interrupt pin to microcontroller
5	SDI	DI	Serial interface data input
6	SCK	DI	Serial interface clock
7	SDO	DO	Serial interface data output from MRF24J40
8	$\overline{\text{CS}}$	DI	Serial interface enable
9	NC	—	No connection (allow pin to float; do not connect signal)
10	V _{IN}	Power	Power supply
11	GND	Ground	Ground
12	GND	Ground	Ground

Legend: Pin type abbreviation: D = Digital, I = Input, O = Output

FIGURE 1-2: MICROCONTROLLER TO MRF24J40MA INTERFACE

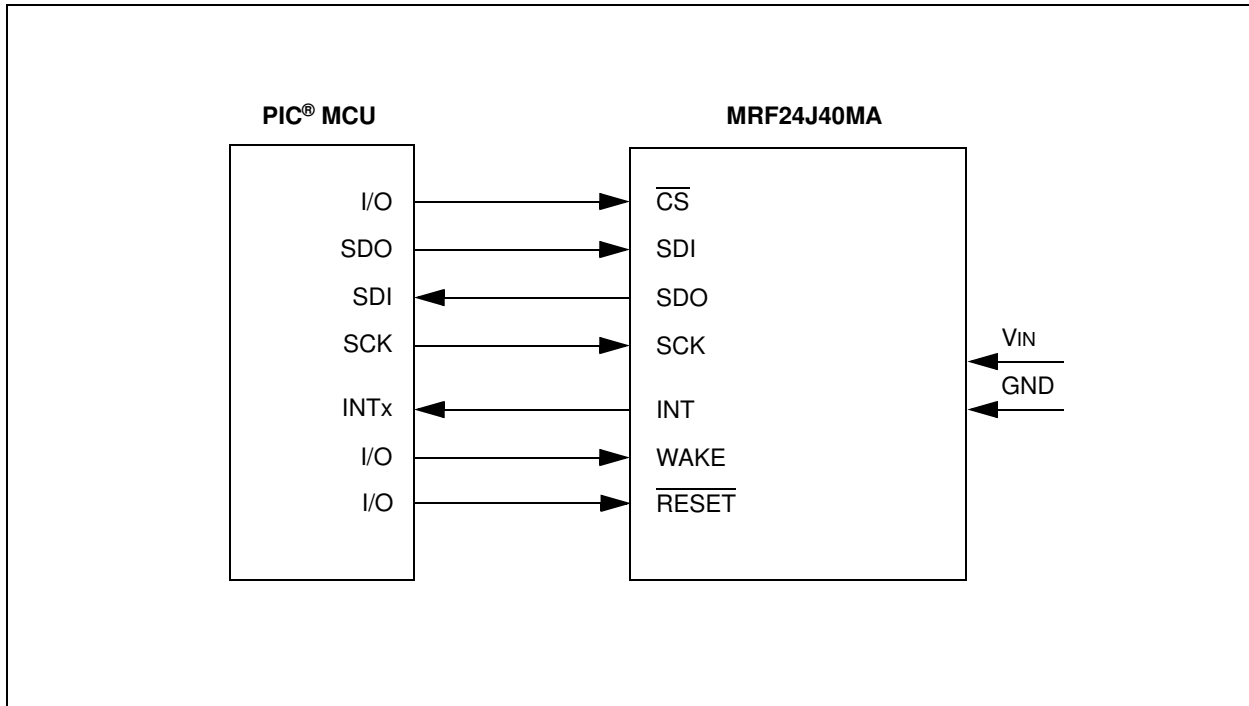

1.2 Mounting Details

The MRF24J40MA is a surface mountable module. Module dimensions are shown in Figure 1-3. The module Printed Circuit Board (PCB) is 0.032" thick with castellated mounting points on the edge. Figure 1-4 is a recommended host PCB footprint for the MRF24J40MA.

The MRF24J40MA has an integrated PCB antenna. For the best performance, follow the mounting details shown in Figure 1-5. It is recommended that the module be mounted on the edge of the host PCB, and an area around the antenna, approximately 1.2", be kept clear of metal objects. A host PCB ground plane around the MRF24J40MA acts as a counterpoise to the PCB antenna. It is recommended to extend the ground plane at least 0.4" around the module.

FIGURE 1-3: MODULE DETAILS

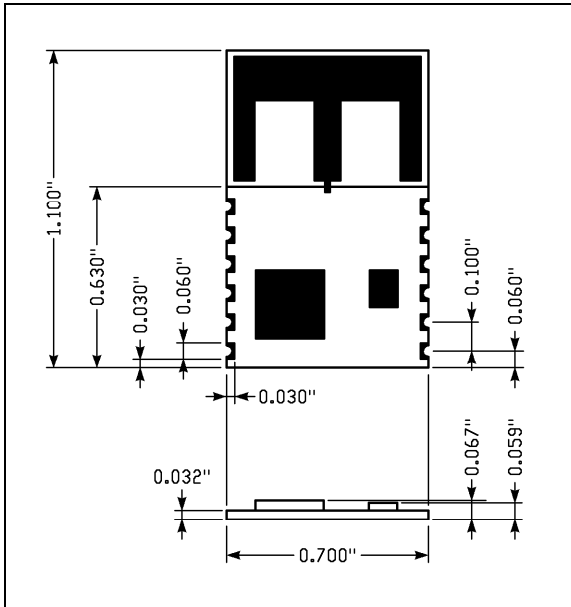
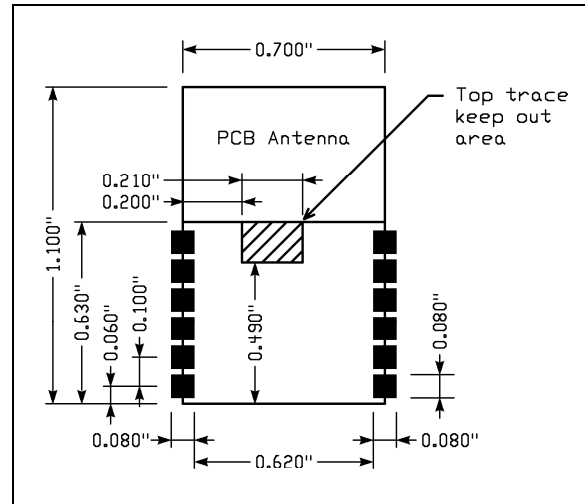
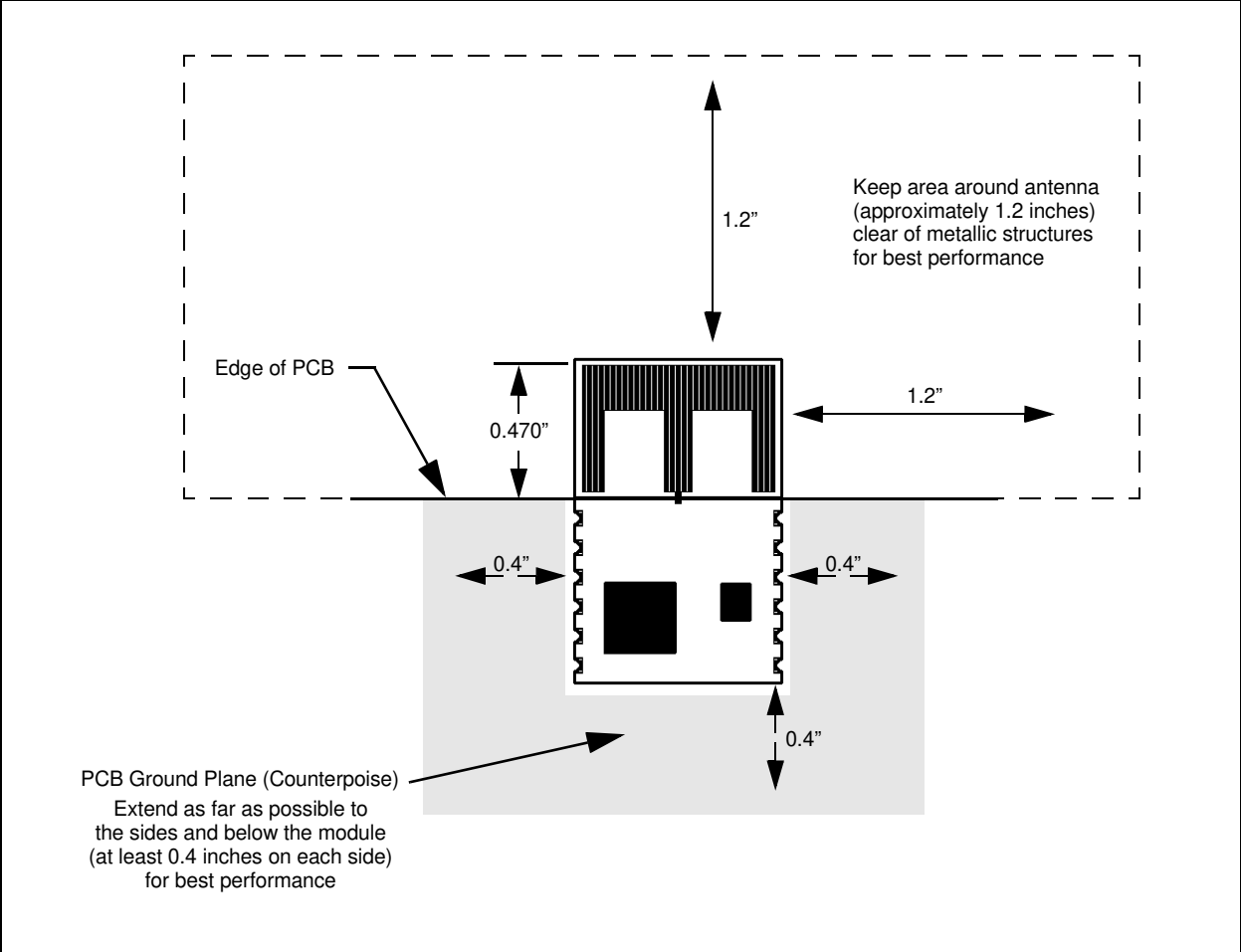

FIGURE 1-4: RECOMMENDED PCB FOOTPRINT



MRF24J40MA

FIGURE 1-5: MOUNTING DETAILS



2.0 CIRCUIT DESCRIPTION

The MRF24J40MA is a complete 2.4 GHz IEEE Std. 802.15.4™ compliant surface mount module with integrated crystal, internal voltage regulator, matching circuitry and PCB antenna. The MRF24J40MA module interfaces to many popular Microchip PIC micro-controllers via a 4-wire serial SPI interface, interrupt, wake, Reset, power and ground. Data communications with the MRF24J40MA module are documented in the “*MRF24J40 IEEE 802.15.4™ 2.4 GHz RF Transceiver Data Sheet*” (DS39776). Refer to the MRF24J40 Data Sheet for specific serial interface protocol and register definitions.

2.1 Schematic

A schematic diagram of the module is shown in Figure 2-1 and the Bill of Materials (BOM) is shown in Table 2-1.

The MRF24J40MA module is based on the Microchip Technology MRF24J40 IEEE 802.15.4™ 2.4 GHz RF Transceiver IC. The serial I/O (SCK, SDI, SDO and CS), RESET, WAKE and INT pins are brought out to the module pins. The SDO signal is tri-state buffered by IC2 to solve a silicon errata, where the SDO signal does not release to a high-impedance state, after the CS pin returns to its inactive state. Crystal, X1, is a 20 MHz crystal with a frequency tolerance of ± 10 ppm @ 25°C to meet the IEEE Std. 802.15.4 symbol rate tolerance of ± 40 ppm. A balun is formed by components: L1, L3, C2 and C14. L2 is an RF choke and pull-up for the RFP and RFN pins on the MRF24J40. C15 is a DC block capacitor. A low-pass filter is formed by components: L4, C16 and C17. The remaining capacitors provide RF and digital bypass.

MRF24J40MA

FIGURE 2-1: MRF24J40MA SCHEMATIC

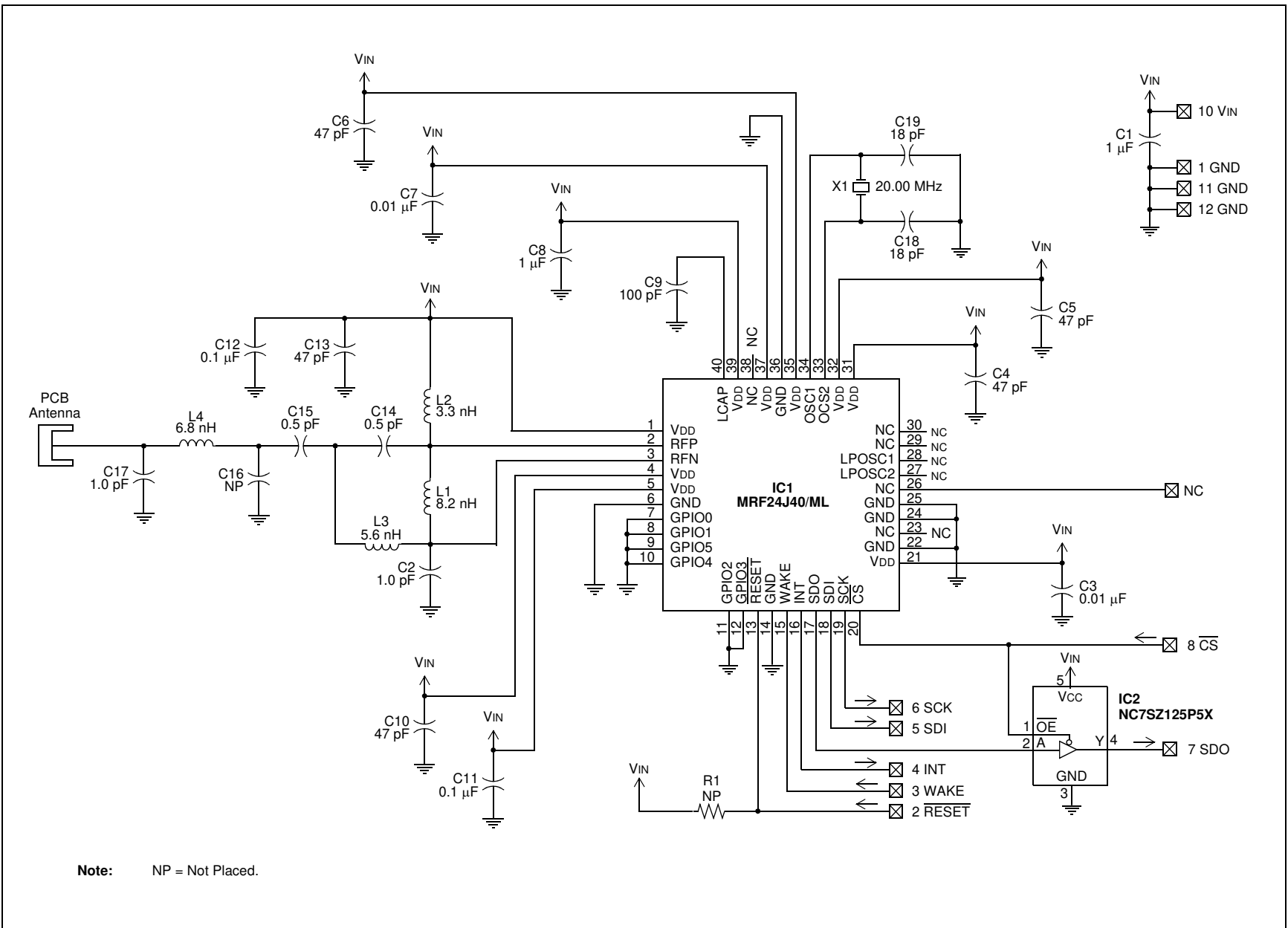

MRF24J40MA

TABLE 2-1: MRJ24J40MA BILL OF MATERIALS

Designator	Description	Manufacturer	Part Number
C1	Chip Capacitor 0402 X5R 1U	Murata	GRM155R60J105ME19D
C2	Chip Capacitor 0402 COG 1.0P	Murata	GRM1555C1H1R0CZ01D
C3	Chip Capacitor 0402 X7R 10N	Murata	GRM155R71E103KA01D
C4	Chip Capacitor 0402 COG 47P	Murata	GRM1555C1H470JZ01D
C5	Chip Capacitor 0402 COG 47P	Murata	GRM1555C1H470JZ01D
C6	Chip Capacitor 0402 COG 47P	Murata	GRM1555C1H470JZ01D
C7	Chip Capacitor 0402 X7R 10N	Murata	GRM155R71E103KA01D
C8	Chip Capacitor 0402 X5R 1U	Murata	GRM155R60J105ME19D
C9	Chip Capacitor 0402 COG 100P	Murata	GRM1555C1H101JZ01D
C10	Chip Capacitor 0402 COG 47P	Murata	GRM1555C1H470JZ01D
C11	Chip Capacitor 0402 X5R 100N	Murata	GRM155R61A104KA01D
C12	Chip Capacitor 0402 X5R 100N	Murata	GRM155R61A104KA01D
C13	Chip Capacitor 0402 COG 47P	Murata	GRM1555C1H470JZ01D
C14	Chip Capacitor 0402 COG 0.5P	Murata	GRM1555C1HR50CZ01D
C15	Chip Capacitor 0402 COG 0.5P	Murata	GRM1555C1HR50CZ01D
C16	Not Placed		
C17	Chip Capacitor 0402 COG 1.0P	Murata	GRM1555C1H1R0CZ01D
C18	Chip Capacitor 0402 COG 18P	Murata	GRM1555C1H180JZ01D
C19	Chip Capacitor 0402 COG 18P	Murata	GRM1555C1H180JZ01D
IC1	IEEE 802.15.4™ RF Transceiver	Microchip	MRF24J40-I/ML
IC2	Buffer, SC70 Package	Fairchild	NC7SZ125P5X
L1	Chip Inductor 0402 8.2N	Panasonic	ELJ-RF8N2JFB
L2	Chip Inductor 0402 3.3N	Panasonic	ELJ-RF3N3DFB
L3	Chip Inductor 0402 5.6N	Panasonic	ELJ-RF5N6DFB
L4	Chip Inductor 0402 6.8N	Panasonic	ELJ-RF6N8JFB
R1	Not Placed		
X1	20 MHz Crystal	Abracon	ABM8-156-20.0000MHZ-T

MRF24J40MA

2.2 Printed Circuit Board

The MRF24J40MA module printed circuit board is constructed with FR4 material, four layers and 0.032 inches thick. The layers are shown in Figure 2-2 through Figure 2-6. The stack up of the PCB is shown in Figure 2-7.

FIGURE 2-2: TOP SILK SCREEN

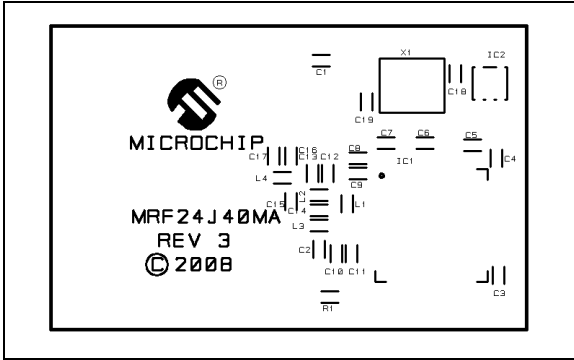

FIGURE 2-3: TOP COPPER

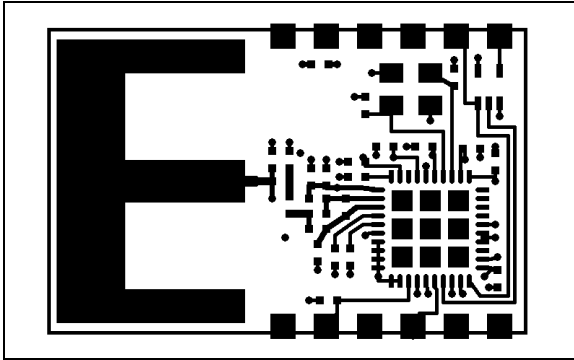

FIGURE 2-4: LAYER 2 – GROUND PLANE

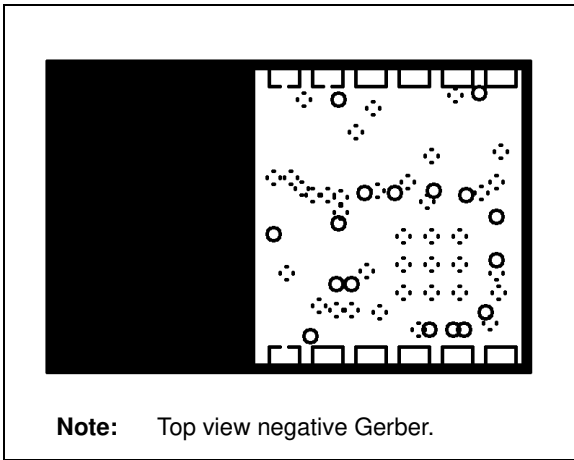

FIGURE 2-5: LAYER 3 – POWER PLANE

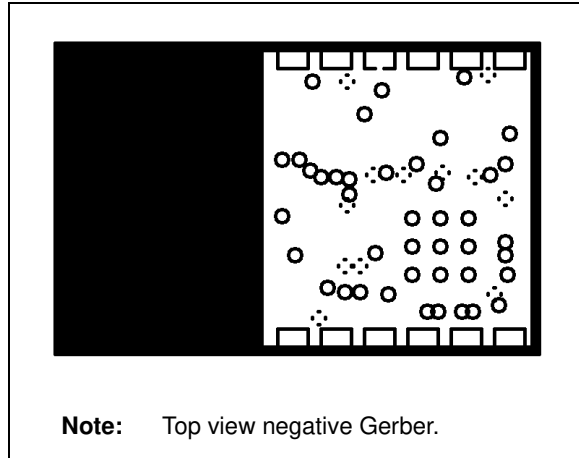

FIGURE 2-6: BOTTOM COPPER

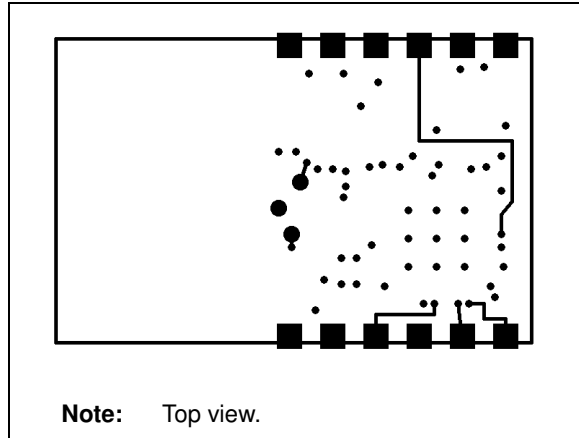
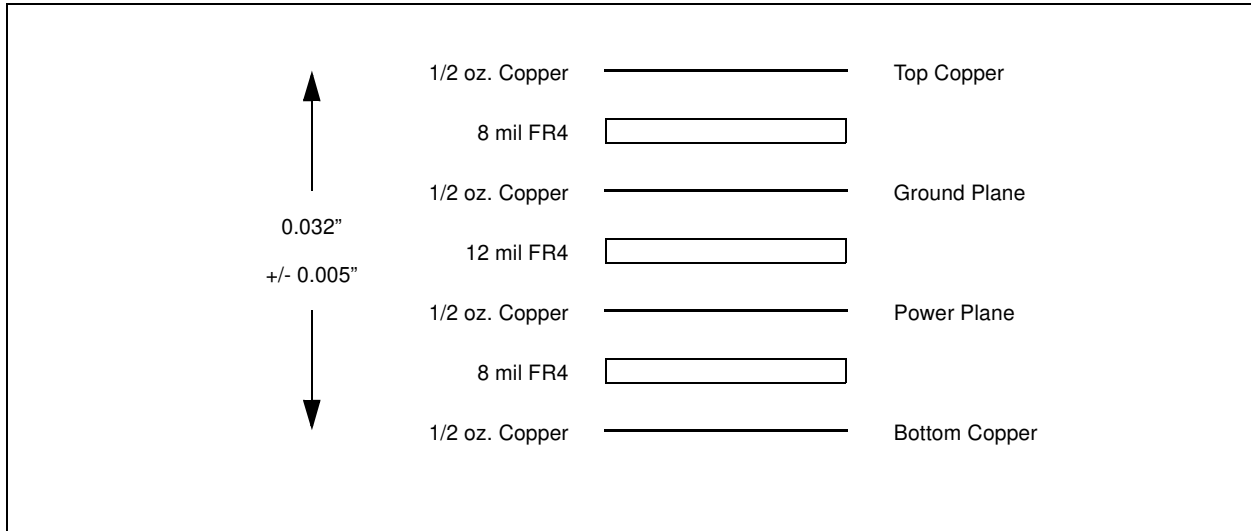

FIGURE 2-7: PCB LAYER STACK UP



MRF24J40MA

2.3 PCB Antenna

The PCB antenna is fabricated on the top copper trace. Figure 2-8 shows the trace dimensions. The layers below the antenna have no copper traces. The ground and power planes under the components serve as a counterpoise to the PCB antenna. Additional ground plane on the host PCB will substantially enhance the performance of the module. For best performance, place the module on the host PCB following the recommendations in **Section 1.2 “Mounting Details”**.

The Printed Circuit Board (PCB) antenna was designed and simulated using Ansoft Designer[®] and HFSS[™] 3D full-wave solver software by Ansoft Corporation (www.ansoft.com). The design goal was to create a compact, low-cost antenna with the best radiation pattern. Figure 2-9 shows the simulation drawing and Figure 2-10 and Figure 2-11 show the 2D and 3D radiation patterns, respectively. As shown by the radiation patterns, the performance of the antenna is dependant upon the orientation of the module. Figure 2-12 shows the impedance simulation and Figure 2-13 shows the actual impedance measurement. The discrete matching circuitry matches the impedance of the antenna with the MRF24J40 transceiver IC.

FIGURE 2-8: PCB ANTENNA DIMENSIONS

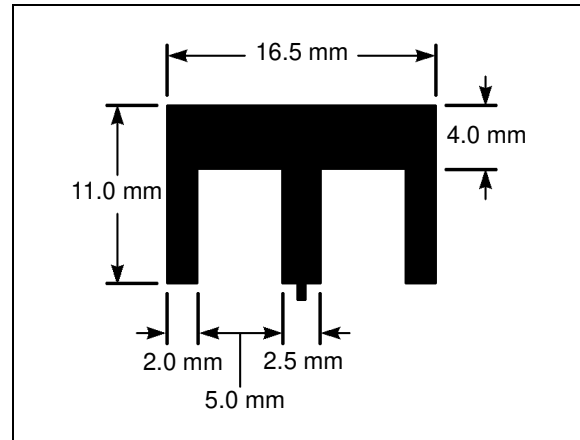

FIGURE 2-9: PCB ANTENNA SIMULATION DRAWING

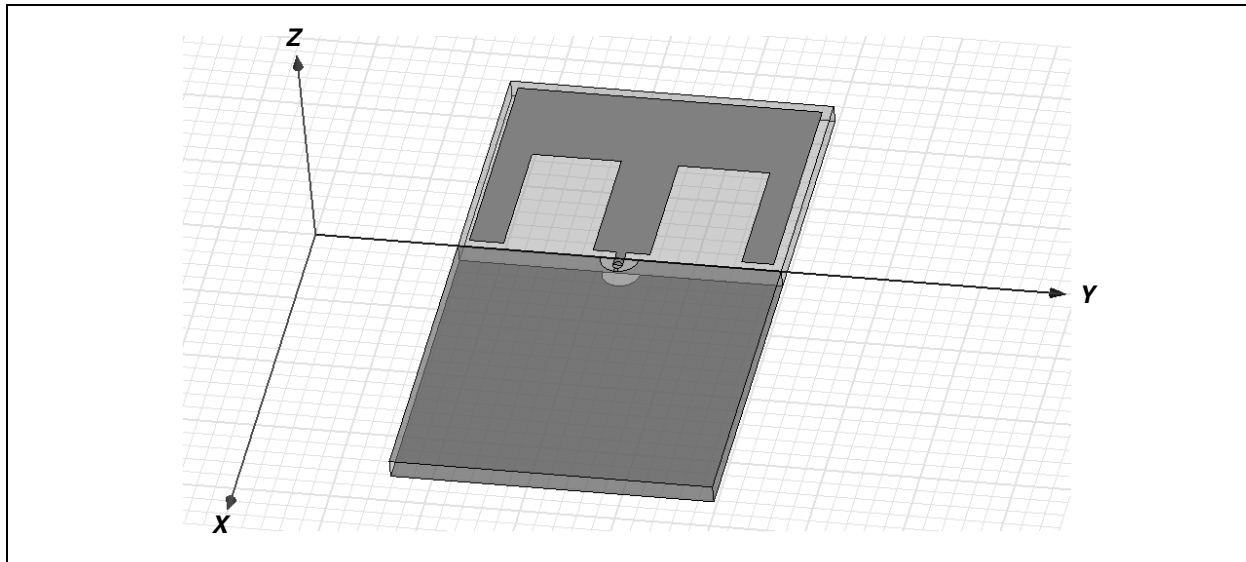

FIGURE 2-10: SIMULATED 2D RADIATION PATTERN

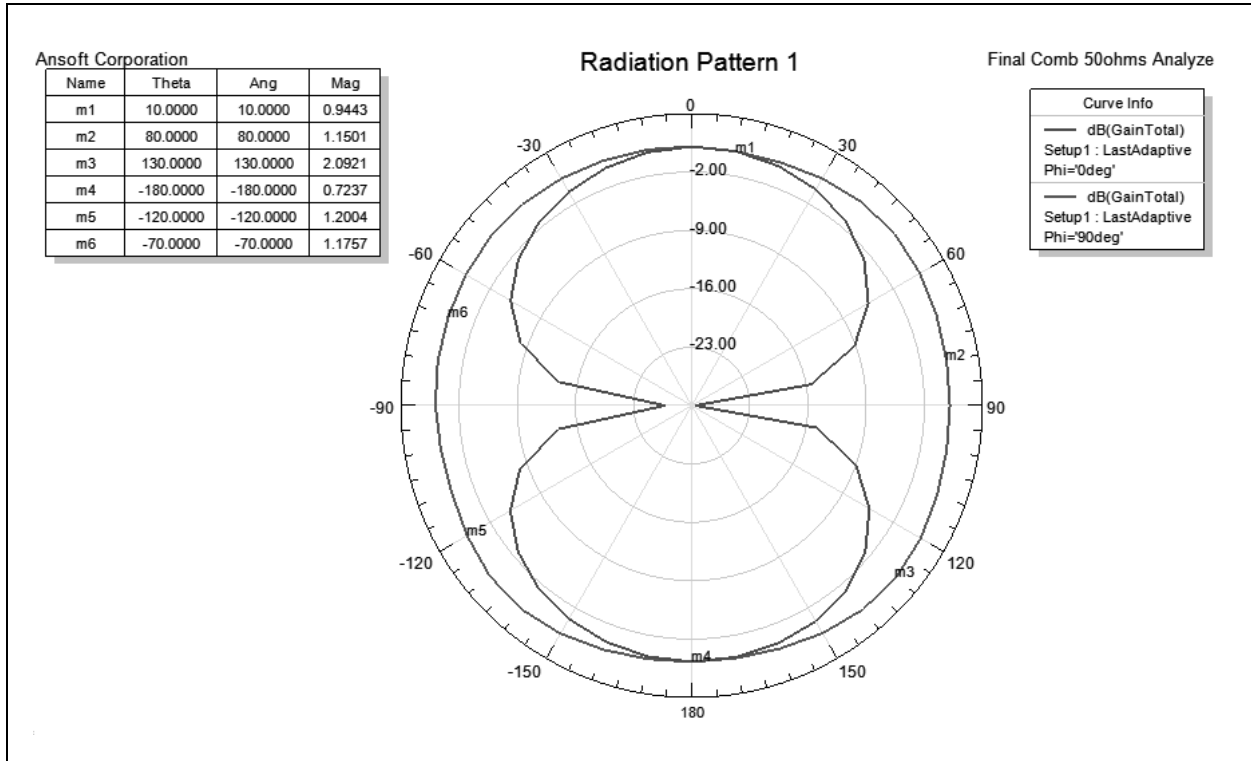
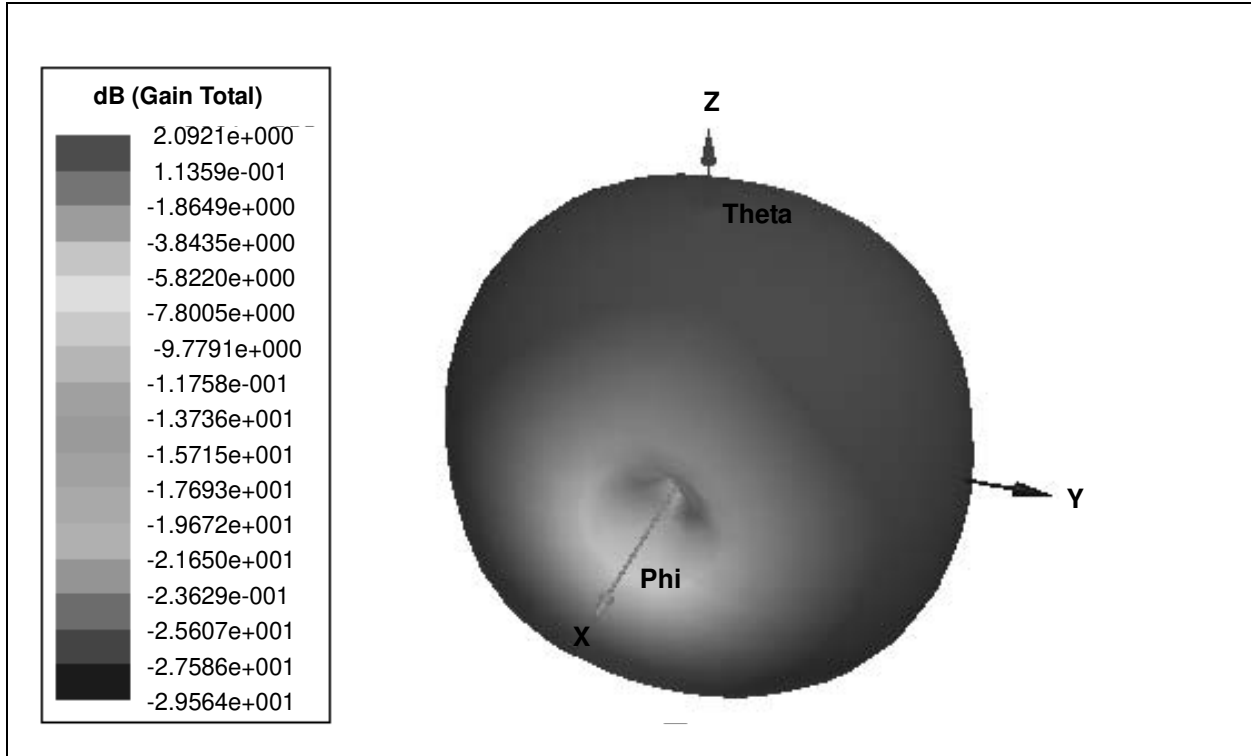

FIGURE 2-11: SIMULATED 3D RADIATION PATTERN



MRF24J40MA

FIGURE 2-12: SIMULATED PCB ANTENNA IMPEDANCE

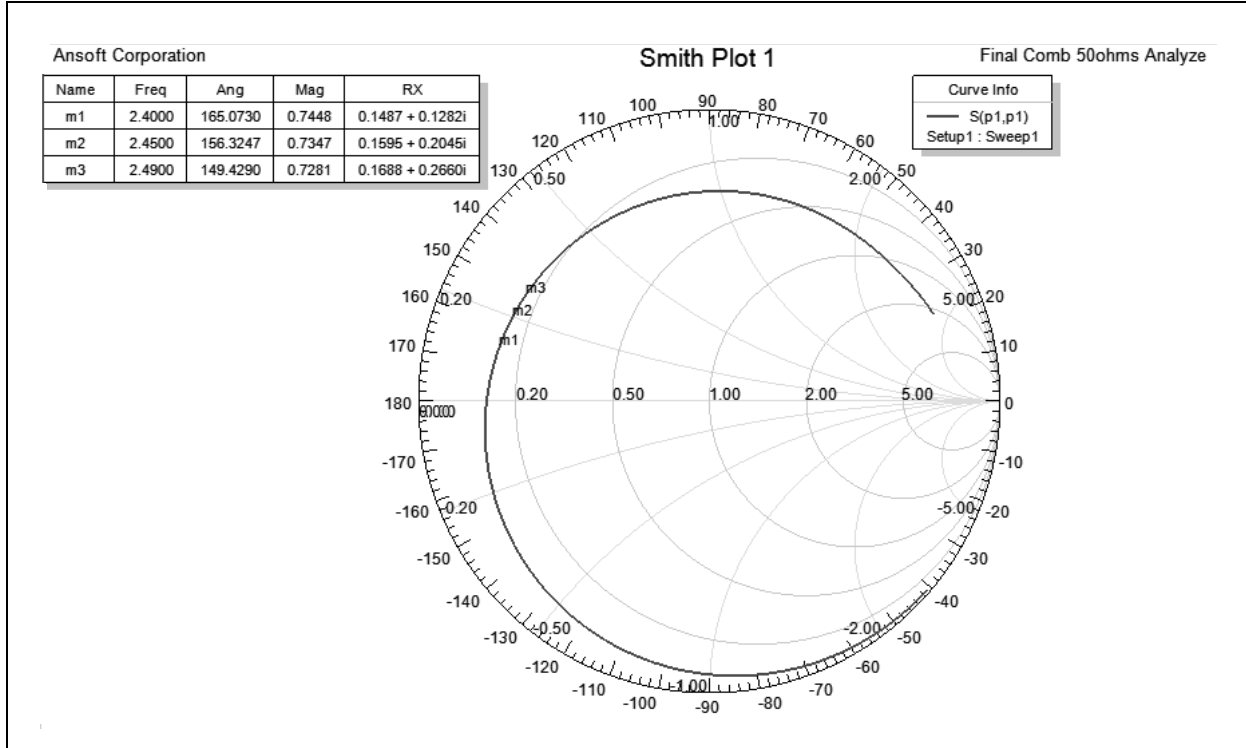
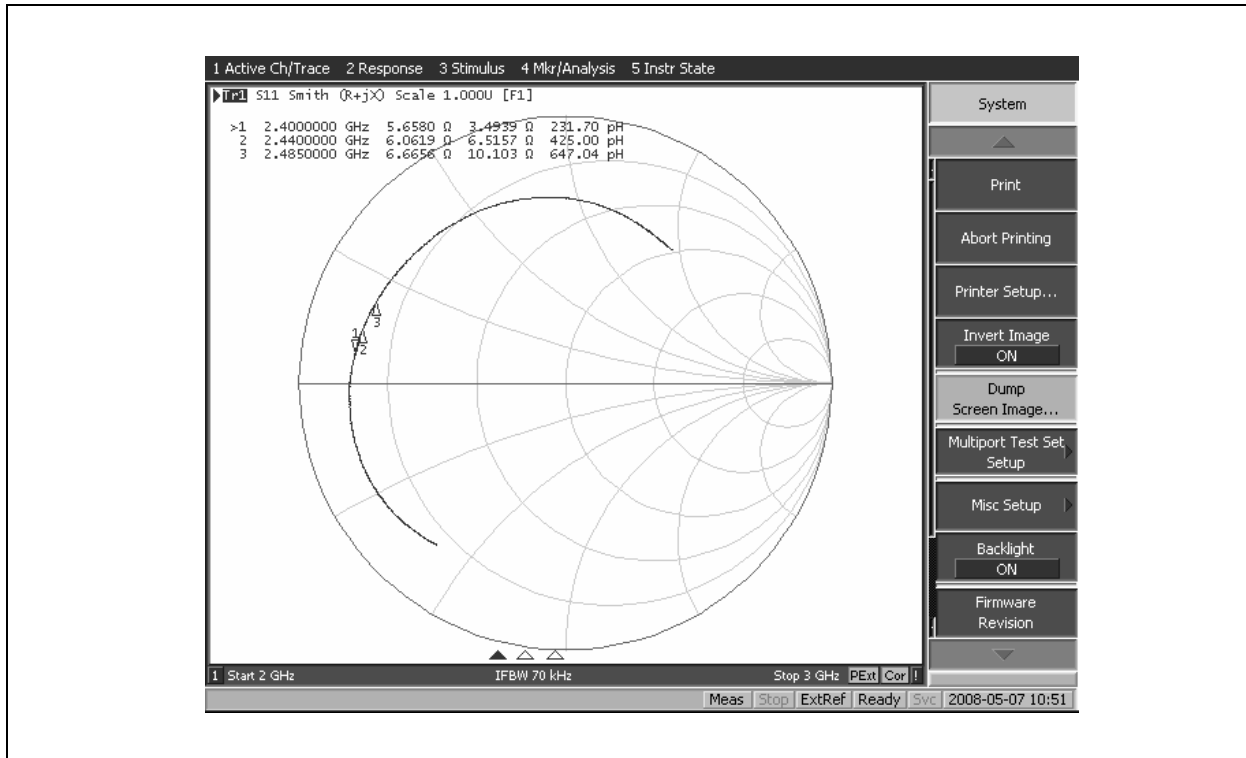

FIGURE 2-13: MEASURED PCB ANTENNA IMPEDANCE



3.0 REGULATORY APPROVAL

The MRF24J40MA module has received regulatory approvals for modular devices in the United States, Canada and European countries. Modular approval allows the end user to place the MRF24J40MA module inside a finished product and not require regulatory testing for an intentional radiator (RF transmitter), provided no changes or modifications are made to the module circuitry. Changes or modifications could void the user's authority to operate the equipment. The end user must comply with all of the instructions provided by the Grantee, which indicate installation and/or operating conditions necessary for compliance.

The integrator may still be responsible for testing the end product for any additional compliance requirements required with this module installed (for example: digital device emission, PC peripheral requirements, etc.) in the specific country that the end device will be marketed.

Annex F of the IEEE Std. 802.15.4 document has a good summary of regulatory requirements in various countries concerning IEEE Std. 802.15.4 devices. The standard can be downloaded from the IEEE Standards web page: <http://standards.ieee.org/getieee802/802.15.html>.

Refer to the specific country radio regulations for details on regulatory compliance.

3.1 United States

The MRF24J40MA has received Federal Communications Commission (FCC) CFR47 Telecommunications, Part 15 Subpart C "Intentional Radiators" 15.247 and modular approval in accordance with FCC Public Notice DA 00-1407 Released: June 26, 2000, Part 15 Unlicensed Modular Transmitter Approval. The MRF24J40MA module can be integrated into a finished product without obtaining subsequent and separate FCC approvals.

The MRF24J40MA module has been labeled with its own FCC ID number, and if the FCC ID is not visible when the module is installed inside another device, then the outside of the finished product into which the module is installed must also display a label referring to the enclosed module. This exterior label can use wording such as the following:

Contains Transmitter Module FCC ID:
OA3MRF24J40MA
-or-
Contains FCC ID: OA3MRF24J40MA
This device complies with Part 15 of the FCC Rules. Operation is subject to the following two conditions:
(1) this device may not cause harmful interference, and (2) this device must accept any interference received, including interference that may cause undesired operation.

The user's manual should include the following statement:

This equipment has been tested and found to comply with the limits for a Class B digital device, pursuant to part 15 of the FCC Rules. These limits are designed to provide reasonable protection against harmful interference in a residential installation. This equipment generates, uses and can radiate radio frequency energy, and if not installed and used in accordance with the instructions, may cause harmful interference to radio communications. However, there is no guarantee that interference will not occur in a particular installation. If this equipment does cause harmful interference to radio or television reception, which can be determined by turning the equipment off and on, the user is encouraged to try to correct the interference by one or more of the following measures:

- Reorient or relocate the receiving antenna.
- Increase the separation between the equipment and receiver.
- Connect the equipment into an outlet on a circuit different from that to which the receiver is connected.
- Consult the dealer or an experienced radio/TV technician for help.

3.1.1 RF EXPOSURE

All transmitters regulated by FCC must comply with RF exposure requirements. OET Bulletin 65 "Evaluating Compliance with FCC Guidelines for Human Exposure to Radio Frequency Electromagnetic Fields" provides assistance in determining whether proposed or existing transmitting facilities, operations or devices comply with limits for human exposure to Radio Frequency (RF) fields adopted by the Federal Communications Commission (FCC). The bulletin offers guidelines and suggestions for evaluating compliance.

If appropriate, compliance with exposure guidelines for mobile and unlicensed devices can be accomplished by the use of warning labels and by providing users with information concerning minimum separation distances from transmitting structures and proper installation of antennas.

MRF24J40MA

The following statement must be included as a CAUTION statement in manuals and OEM products to alert users of FCC RF Exposure compliance:

To satisfy FCC RF Exposure requirements for mobile and base station transmission devices, a separation distance of 20 cm or more should be maintained between the antenna of this device and persons during operation. To ensure compliance, operation at closer than this distance is not recommended.

The antenna(s) used for this transmitter must not be co-located or operating in conjunction with any other antenna or transmitter.

If the MRF24J40MA module is used in a portable application (antenna is less than 20 cm from persons during operation), the integrator is responsible for performing Specific Absorption Rate (SAR) testing in accordance with FCC rules 2.1091.

3.1.2 HELPFUL WEB SITES

Federal Communications Commission (FCC):
<http://www.fcc.gov>

3.2 Canada

The MRF24J40MA module has been certified for use in Canada under Industry Canada (IC) Radio Standards Specification (RSS) RSS-210 and RSS-Gen.

From Section 7.1.1, RSS-Gen, Issue 2, June 2007, Modular Transmitter Approval:

Host devices which contain separately certified modules do not need to be recertified, provided that they meet the following conditions:

- a) The host device, as a stand-alone unit without any separately certified modules, complies with all applicable Radio Standards Specifications.
- b) The host device and all the separately certified modules it contains jointly meet the RF exposure compliance requirements of RSS-102, if applicable.
- c) The host device complies with the certification labeling requirements of each of the modules it contains.

Note: Compliance of a module in its final configuration is the responsibility of the applicant. A host device will not be considered certified if the instructions regarding antenna configuration provided in the original description, of one or more separately certified modules it contains, were not followed

From Section 5.2, RSS-Gen, Issue 2, June 2007, Equipment Labels:

All Category I radio equipment intended for use in Canada shall permanently display on each transmitter, receiver or inseparable combination thereof, the applicant's name (i.e., manufacturer's name, trade name or brand name), model number and certification number. This information shall be affixed in such a manner as to not be removable except by destruction or defacement. The size of the lettering shall be legible without the aid of magnification, but is not required to be larger than 8-point font size. If the device is too small to meet this condition, the information can be included in the user manual upon agreement with Industry Canada.

Label:

Contains IC: 7693A-24J40MA

From Section 7.1.6, RSS-Gen, Issue 2, June 2007, Digital Circuits:

If the device contains digital circuitry that is not directly associated with the radio transmitter, the device shall also have to comply with ICES-003, Class A or B as appropriate, except for ICES-003 labeling requirements. The test data obtained (for the ICES-003 tests) shall be kept by the manufacturer or importer whose name appears on the equipment label, and made available to Industry Canada on request, for as long as the model is being marketed in Canada.

3.2.1 HELPFUL WEB SITES

Industry Canada: <http://www.ic.gc.ca/>

3.3 Europe

The MRF24J40MA module has been certified for use in European countries. The following testing has been completed:

Test standard ETSI EN 300 328 V1.7.1 (2006-10):

- Maximum Transmit Power
- Maximum EIRP Spectral Density
- Frequency Range
- Radiated Emissions

Test standards ETSI EN 301 489-1:2008 and ETSI EN 301 489-17:2008:

- Radiated Emissions
- Electro-Static Discharge
- Radiated RF Susceptibility

A helpful document that can be used as a starting point in understanding the use of Short Range Devices (SRD) in Europe is the European Radio Communications Committee (ERC) Recommendation 70-03 E, downloadable from the European Radio Communications Office (ERO): <http://www.ero.dk>.

The end user is responsible for ensuring compliance with harmonized frequencies and labeling requirements for each country the end device is marketed and sold.

3.3.1 HELPFUL WEB SITES:

Radio and Telecommunications Terminal Equipment (R&TTE):

http://ec.europa.eu/enterprise/rtte/index_en.htm

European Conference of Postal and Telecommunications Administrations (CEPT): <http://www.cept.org/>

European Telecommunications Standards Institute (ETSI): <http://www.etsi.org/>

European Radio Communications Office (ERO): <http://www.ero.dk/>

MRF24J40MA

NOTES:

4.0 ELECTRICAL CHARACTERISTICS

TABLE 4-1: RECOMMENDED OPERATING CONDITIONS

Parameters	Min	Typ	Max	Units
Ambient Operating Temperature	-40	—	+85	°C
Supply Voltage for RF, Analog and Digital Circuits	2.4	—	3.6	V
Supply Voltage for Digital I/O	2.4	3.3	3.6	V
Input High Voltage (V _{IH})	0.5 x V _{DD}	—	V _{DD} + 0.3	V
Input Low Voltage (V _{IL})	-0.3	—	0.2 x V _{DD}	V

TABLE 4-2: CURRENT CONSUMPTION

(T_A = 25°C, V_{DD} = 3.3V)

Chip Mode	Condition	Min	Typ	Max	Units
Sleep	Sleep Clock Disabled	—	2	—	μA
TX	At Maximum Output Power	—	23	—	mA
RX		—	19	—	mA

TABLE 4-3: RECEIVER AC CHARACTERISTICS

Typical values are at T_A = 25°C, V_{DD} = 3.3V, LO Frequency = 2.445 GHz

Parameters	Condition	Min	Typ	Max	Units
RF Input Frequency	Compatible to IEEE Std. 802.15.4™, 2003	2.405	—	2.480	GHz
RF Sensitivity		—	-94	—	dBm
Maximum RF Input		+5	—	—	dBm
LO Leakage	Measured at Balun Matching Network Input at Frequency, 2.405-2.48 GHz	—	-60	—	dBm
Input Return Loss	Externally Matched to 50 ohm Source by a Balun Matching Network	-8	-12	—	dB
Noise Figure (including matching)		—	8	—	dB
Adjacent Channel Rejection	@ +/-5 MHz	30	—	—	dB
Alternate Channel Rejection	@ +/-10 MHz	40	—	—	dB
RSSI Range		—	50	—	dB
RSSI Error		-5	—	5	dB

MRF24J40MA

TABLE 4-4: TRANSMITTER AC CHARACTERISTICS

Typical values are at TA = 25°C, VDD = 3.3V, LO Frequency = 2.445 GHz

Parameters	Condition	Min	Typ	Max	Units
RF Carrier Frequency		2.405	—	2.480	GHz
Maximum RF Output Power		—	0	—	dBm
RF Output Power Control Range		—	36	—	dB
TX Gain Control Resolution	Programmed by Register	—	1.25	—	dB
Carrier Suppression		—	-30	—	dBc
TX Spectrum Mask for O-QPSK Signal	Offset Frequency > 3.5 MHz, at 0 dBm Output Power	-33	—	—	dBm
TX EVM		—	15	—	%

APPENDIX A: REVISION HISTORY

Revision A (June 2008)

Original data sheet for the MRF24J40MA device.

Revision B (November 2008)

Changed C17 to 1.0 pF and removed CLKOUT signal.

MRF24J40MA

NOTES:

INDEX

A

AC Characteristics	
Receiver	19
Transmitter	20
Antenna Impedance	
Measured PCB	14
Simulated PCB	14

B

Block Diagrams	
Microcontroller to MRF24J40MA Interface	4
MRF24J40MA	3

C

Circuit Description	7
Customer Change Notification Service	24
Customer Notification Service	24
Customer Notification System	2
Customer Support	24

E

Electrical Characteristics	19
Current Consumption	19
Recommended Operating Conditions	19
Errata	2
European Radio Communications (ERC)	17

F

FCC ID Number	15
FCC RF Exposure Compliance	16

H

Helpful Web Sites	16, 17
-------------------------	--------

I

Interface Description	3
Internet Address	24

M

MAC/Baseband Features	1
Microchip Internet Web Site	24
MiWi P2P	3
MiWi Protocol	3
More Information	2
Customer Notification System	2
Errata	2
Mounting Details	5
MRF24J40 Data Sheet	3, 7
MRF24J40MA Bill of Materials (BOM)	9
MRF24J40MA Schematic	8

O

Overview	3
----------------	---

P

PCB Antenna	12
Dimensions	12
Simulation Drawing	12
PCB Layers	
Bottom Copper	10
Layer 2 – Ground Plane	10
Layer 3 – Power Plane	10
Stack Up	11
Top Copper	10
Top Silk Screen	10
Pin Description	4
Pin Diagram	1
Printed Circuit Board (PCB)	10

R

Radiation Pattern	
2D	13
3D	13
Reader Response	25
Regulatory Approval	15
Canada	16
Europe	17
United States	15
Revision History	21
RF Exposure	15
RF/Analog Features	1

S

Serial I/O	
SCK, SDI, SDO, \overline{CS}	7
Short Range Devices (SRD)	17
Specific Absorption Rate (SAR)	16
SPI	7

W

WWW Address	24
WWW, On-Line Support	2

Z

ZigBee Protocol	3
-----------------------	---