



Chipsmall Limited consists of a professional team with an average of over 10 year of expertise in the distribution of electronic components. Based in Hongkong, we have already established firm and mutual-benefit business relationships with customers from,Europe,America and south Asia,supplying obsolete and hard-to-find components to meet their specific needs.

With the principle of “Quality Parts,Customers Priority,Honest Operation,and Considerate Service”,our business mainly focus on the distribution of electronic components. Line cards we deal with include Microchip,ALPS,ROHM,Xilinx,Pulse,ON,Everlight and Freescale. Main products comprise IC,Modules,Potentiometer,IC Socket,Relay,Connector.Our parts cover such applications as commercial,industrial, and automotives areas.

We are looking forward to setting up business relationship with you and hope to provide you with the best service and solution. Let us make a better world for our industry!



## Contact us

Tel: +86-755-8981 8866 Fax: +86-755-8427 6832

Email & Skype: info@chipsmall.com Web: www.chipsmall.com

Address: A1208, Overseas Decoration Building, #122 Zhenhua RD., Futian, Shenzhen, China





**MICROCHIP**

# MRF24WB0MA/MRF24WB0MB

## MRF24WB0MA/MRF24WB0MB Data Sheet 2.4 GHz IEEE 802.11b™

### Features

- IEEE 802.11-compliant RF Transceiver
- Serialized unique MAC address
- Data Rate: 1 and 2 Mbps
- Compatible with IEEE 802.11b/g/n networks
- Small size: 21 mm x 31 mm 36-pin Surface Mount Module
- Integrated PCB antenna (MRF24WB0MA)
- External antenna option (MRF24WB0MB) with ultra miniature coaxial (UFL) connector
- Range: up to 400m (1300 ft.)
- Easy integration into final product – accelerates product development, provides quicker time to market
- Radio regulation certification for United States (FCC), Canada (IC), Europe (ETSI) and Japan (ARIB)
- Wi-Fi® certified (WFA ID: WFA7150)
- Designed for use with Microchip microcontroller families (PIC18, PIC24, dsPIC33, and PIC32) with downloadable Microchip TCP/IP Stack

### Operational

- Single operating voltage: 2.7V–3.6V (3.3V typical)
- Temperature Range: -40° C to +85° C
- Simple, four-wire SPI interface with interrupt
- Low-current consumption:
  - RX mode – 85 mA (typical)
  - TX mode – 154 mA (+10 dBm typical)
  - Sleep – 250 µA (typical)
  - Hibernate – <0.1 µA (typical)

### RF/Analog Features

- ISM Band 2.400–2.484 GHz operation
- 14 Channels selectable individually or domain-restricted
- DSSS Modulation
- Data Rate – 1000 kbps
- -91 dBm Typical sensitivity at 1 Mbps
- +10 dBm Typical output power with control
- Integrated low phase noise VCO, RF frequency synthesizer, PLL loop filter and PA
- Digital VCO and filter calibration

- Integrated RSSI ADC and I/Q DACs, RSSI readings available to host
- Balanced receiver and transmitter characteristics for low power consumption

### MAC/Baseband Features

- Hardware CSMA/CA access control, automatic ACK, and FCS creation and checking
- Automatic MAC packet retransmit
- Hardware Security Engine for AES and RC4-based ciphers
- Supports 802.1x, 802.1i security: WEP, WPA-PSK, and WPA-2-PSK.
- Supports Infrastructure, ad hoc

### Applications

- Utility and Smart Energy
  - Thermostats
  - Smart Meters
  - HVAC
- Consumer Electronics
  - Remote Control
  - Internet Radio
- Industrial Controls
  - Chemical Sensors
  - HVAC
  - Security Systems
  - M2M Communication
- Remote Device Management
  - Location and Asset Tracking
  - Automotive
- Retail
  - POS Terminals
  - Wireless Price Tags
  - Digital Remote
- Medical, Fitness, and Health care
  - Patient Asset Tracking

**Note:** For products that are intended for use with any Access Point, it is recommended to use MRF24WG0MA/MB.

# MRF24WB0MA/MRF24WB0MB

## Pin Diagram

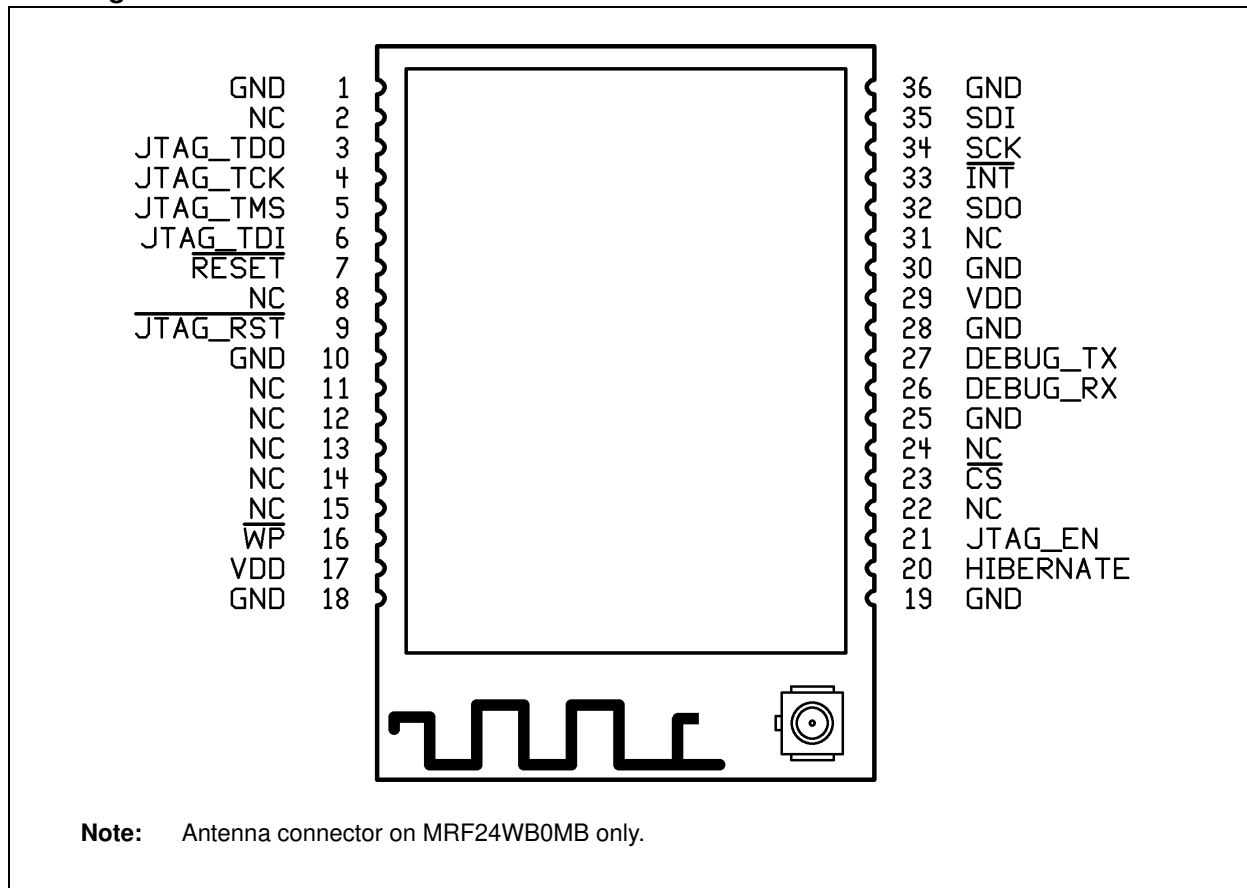

# MRF24WB0MA/MRF24WB0MB

## Table of Contents

1.0	Devices Overview.....	5
2.0	Circuit Description.....	11
3.0	Regulatory Approval.....	21
4.0	Electrical Characteristics.....	27
	Appendix A: Revision History.....	31
	The Microchip Web Site.....	33
	Customer Change Notification Service.....	33
	Customer Support.....	33
	Reader Response.....	34
	Product Identification System.....	35

## TO OUR VALUED CUSTOMERS

It is our intention to provide our valued customers with the best documentation possible to ensure successful use of your Microchip products. To this end, we will continue to improve our publications to better suit your needs. Our publications will be refined and enhanced as new volumes and updates are introduced.

If you have any questions or comments regarding this publication, please contact the Marketing Communications Department via E-mail at [docerrors@microchip.com](mailto:docerrors@microchip.com) or fax the **Reader Response Form** in the back of this data sheet to (480) 792-4150. We welcome your feedback.

### Most Current Data Sheet

To obtain the most up-to-date version of this data sheet, please register at our Worldwide Web site at:  
<http://www.microchip.com>

You can determine the version of a data sheet by examining its literature number found on the bottom outside corner of any page. The last character of the literature number is the version number, (e.g., DS30000A is version A of document DS30000).

### Errata

An errata sheet, describing minor operational differences from the data sheet and recommended workarounds, may exist for current devices. As device/documentation issues become known to us, we will publish an errata sheet. The errata will specify the revision of silicon and revision of document to which it applies.

To determine if an errata sheet exists for a particular device, please check with one of the following:

- Microchip's Worldwide Web site; <http://www.microchip.com>
- Your local Microchip sales office (see last page)

When contacting a sales office, please specify which device, revision of silicon and data sheet (include literature number) you are using.

### Customer Notification System

Register on our web site at [www.microchip.com](http://www.microchip.com) to receive the most current information on all of our products.

# MRF24WB0MA/MRF24WB0MB

---

---

NOTES:

# MRF24WB0MA/MRF24WB0MB

---

## 1.0 DEVICES OVERVIEW

The MRF24WB0MA and MRF24WB0MB are low-power, 2.4 GHz, IEEE 802.11-compliant, surface mount modules with all associated RF components such as crystal oscillator, bypass and bias passives with integrated MAC, baseband, RF and power amplifier, and built-in hardware support for AES, and TKIP (WEP, WPA, WPA2 security). The integrated module design frees the designer from RF and antenna design tasks and regulatory compliance testing, ultimately providing quicker time to market. The MRF24WB0MA module is approved for use with the integrated PCB meander antenna.

The MRF24WB0MB has an ultra miniature coaxial connector (U.FL) and is approved for use with a list of pre-certified antennas. See [Section 2.8, External Antenna](#), for specific recommendations.

The MRF24WB0MA/MRF24WB0MB modules are designed to be used with Microchip's TCP/IP software stack. The software stack has an integrated driver that implements the API that is used in the modules for command and control, and for management and data packet traffic.

The Microchip TCP/IP software stack is available in the *Microchip Application Libraries* for free download (including example applications and source code) from the Microchip web site, <http://www.microchip.com/wireless>.

The combination of the module and a PIC running the TCP/IP stack results in support for IEEE 802.11 and IP services. This allows the immediate implementation of a wireless web server.

The MRF24WB0MA/MRF24WB0MB modules have received regulatory approvals for modular devices in the United States (FCC), Canada (IC), and Europe (ETSI). The modular approval removes the need for expensive RF and antenna design, and allows the end user to place the modules inside a finished product and not require regulatory testing for an intentional radiator (RF transmitter). They also have Radio Type Approval Certification for Japan. See [Section 3.0, Regulatory Approval](#), for the specific requirements that should be adhered to by the integrator.

## 1.1 Interface Description

[Figure 1-1](#) represents a MRF24WB0MA/MRF24WB0MB module. It interfaces to Microchip PIC18, PIC24, dsPIC33, or PIC32 microcontrollers through a four-wire serial slave SPI interface, such as interrupt, hibernate, Reset, power and ground signals. The module runs on a single supply voltage of nominally 3.3V. It also supports optional JTAG and serial debug for testability. The debug port operates at 3.3V and requires a level shifter for operation with RS-232 devices. [Figure 1-2](#) shows a simplified connection between a Microchip's PIC MCU and the module. [Table 1-1](#) lists the pin descriptions.

Data communications with the MRF24WB0MA/MRF24WB0MB are through the SPI interface, for more information see [Section 2.0, Circuit Description](#). Microchip's PIC MCUs communicates with the module through a command API within the Microchip TCP/IP stack. The command API is detailed in the Microchip TCP/IP stack online help that is available in the *Microchip Application Libraries* for free download.

# MRF24WB0MA/MRF24WB0MB

**FIGURE 1-1: MRF24WB0MA/MRF24WB0MB BLOCK DIAGRAM**

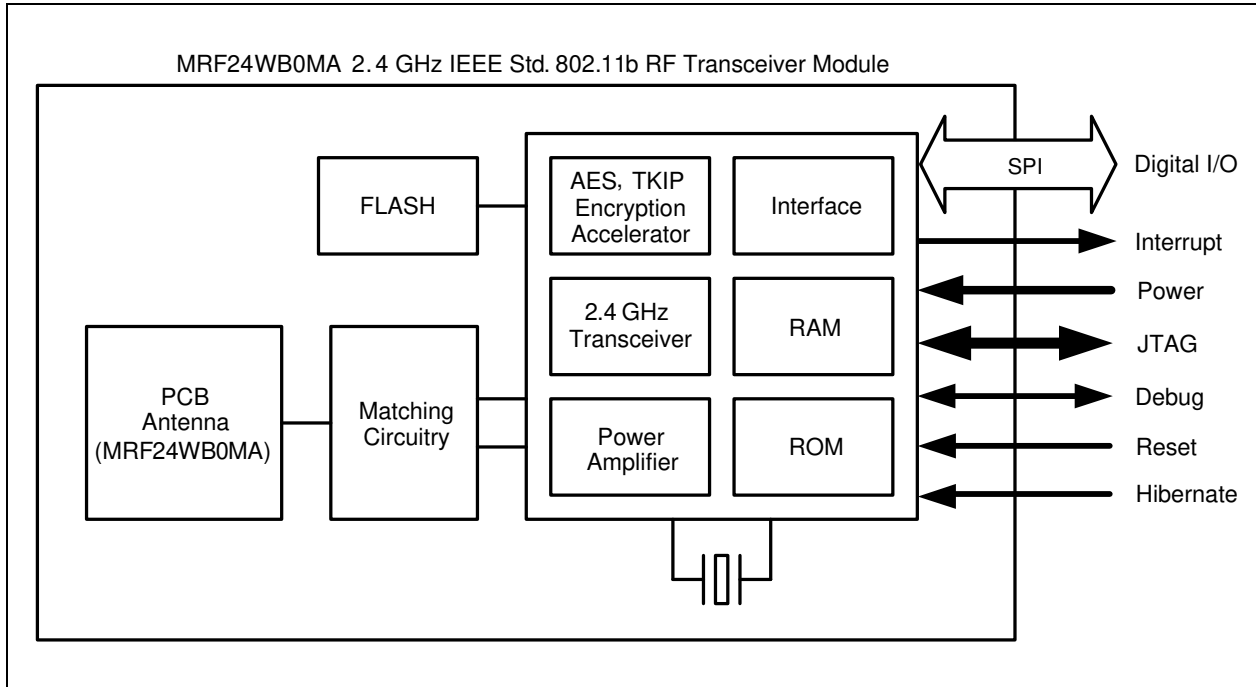

**FIGURE 1-2: MICROCONTROLLER TO MRF24WB0MA/MRF24WB0MB INTERFACE**

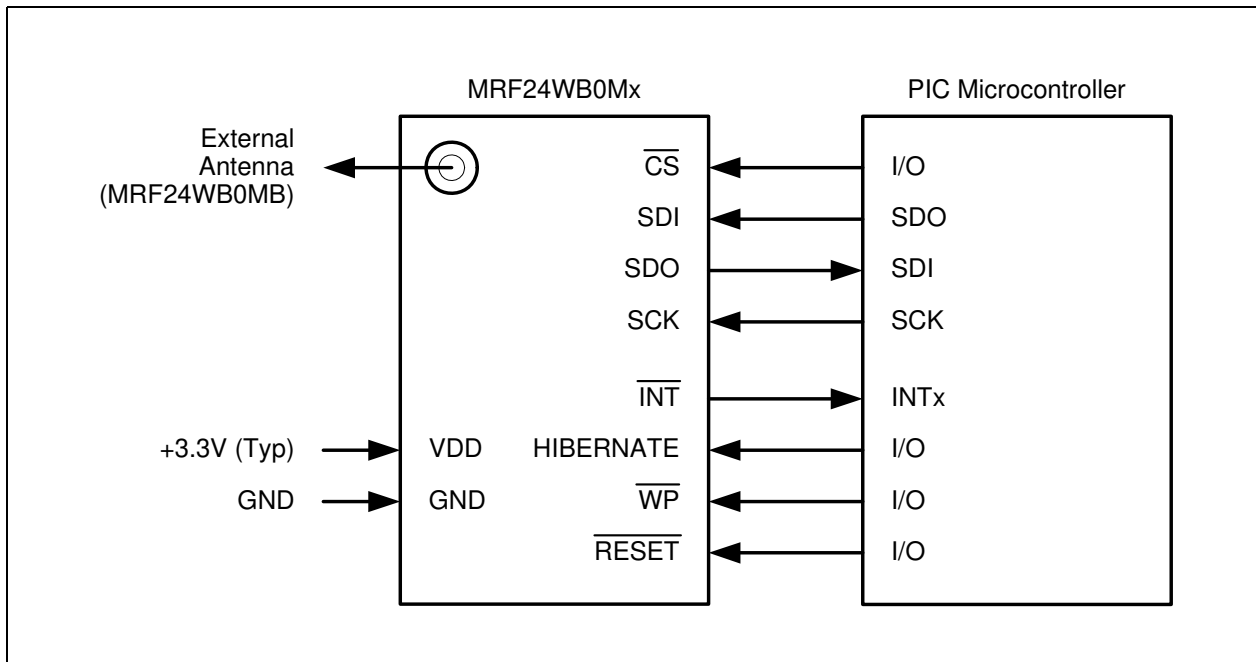

# MRF24WB0MA/MRF24WB0MB

**TABLE 1-1: Pin Description**

Pin	Symbol	Type	Description
1	GND	P	Ground
2	NC	NC	Do not connect
3	JTAGTDO	O	JTAG test data output
4	JTAGTCK	I: Constant <sup>(1)</sup>	JTAG clock input (drive or pull-up only)
5	JTAGTMS	I	JTAG mode input
6	JTAGTDI	I	JTAG test data input
7	$\overline{\text{RESET}}$	I: Constant <sup>(1)</sup>	Module Reset input
8	NC	NC	Do not connect
9	$\overline{\text{JTAGRST}}$	I	JTAG Reset input (optional; see <a href="#">Section 2.0, Circuit Description</a> )
10	GND	P	Ground
11	NC	NC	Do not connect
12	NC	NC	Do not connect
13	NC	NC	Do not connect
14	NC	NC	Do not connect
15	NC	NC	Do not connect
16	$\overline{\text{WP}}^{(2)}$	I	Write protect (this pin is used to enable FLASH update)
17	VDD	P	Power
18	GND	P	Ground
19	GND	P	Ground
20	HIBERNATE	I	Hibernate mode enable (high input will disable the module)
21	JTAGEN	I	JTAG test enable
22	NC	NC	Do not connect
23	$\overline{\text{CS}}$	I: Constant <sup>(1)</sup>	SPI Chip Select input, constant drive or pull-up required
24	NC	NC	Do not connect
25	GND	P	Ground
26	DEBUGRX	I	Serial debug port input (see <a href="#">Section 2.0, Circuit Description</a> )
27	DEBUGTX	O	Serial debug port output (see <a href="#">Section 2.0, Circuit Description</a> )
28	GND	P	Ground
29	VDD	P	Power
30	GND	P	Ground
31	NC	NC	Do not connect
32	SDO	O	SPI data out
33	$\overline{\text{INT}}$	O	Interrupt output (open drain – requires a pull-up)
34	SCK	I	SPI clock input
35	SDI	I	SPI data in
36	GND	P	Ground

**Legend:** Pin type abbreviation: P = Power input, I = Input, O = Output, NC = Do Not Connect

**Note 1:** Signals of Type “I: Constant” must either be constantly driven by the host or have a pull-up or pull-down (in case the host is likely to tri-state the signal during power down modes). The constant drive is used to ensure defined operation of the part and to minimize leakage current during low power modes.

**2:**  $\overline{\text{WP}}$  is used as write-protect for the internal module SPI Flash. For production use, this pin should be pulled low. This pin can be controlled by the host microcontroller to enable in field Flash updates.



# MRF24WB0MA/MRF24WB0MB

## 1.2 Mounting Details

The MRF24WB0MA/MRF24WB0MB is a surface mountable module. Module dimensions are shown in Figure 1-3. The module Printed Circuit Board (PCB) is 1 mm thick with castellated mounting points on two sides.

FIGURE 1-3: MRF24WB0MA/MRF24WB0MB MODULE PHYSICAL DIMENSIONS

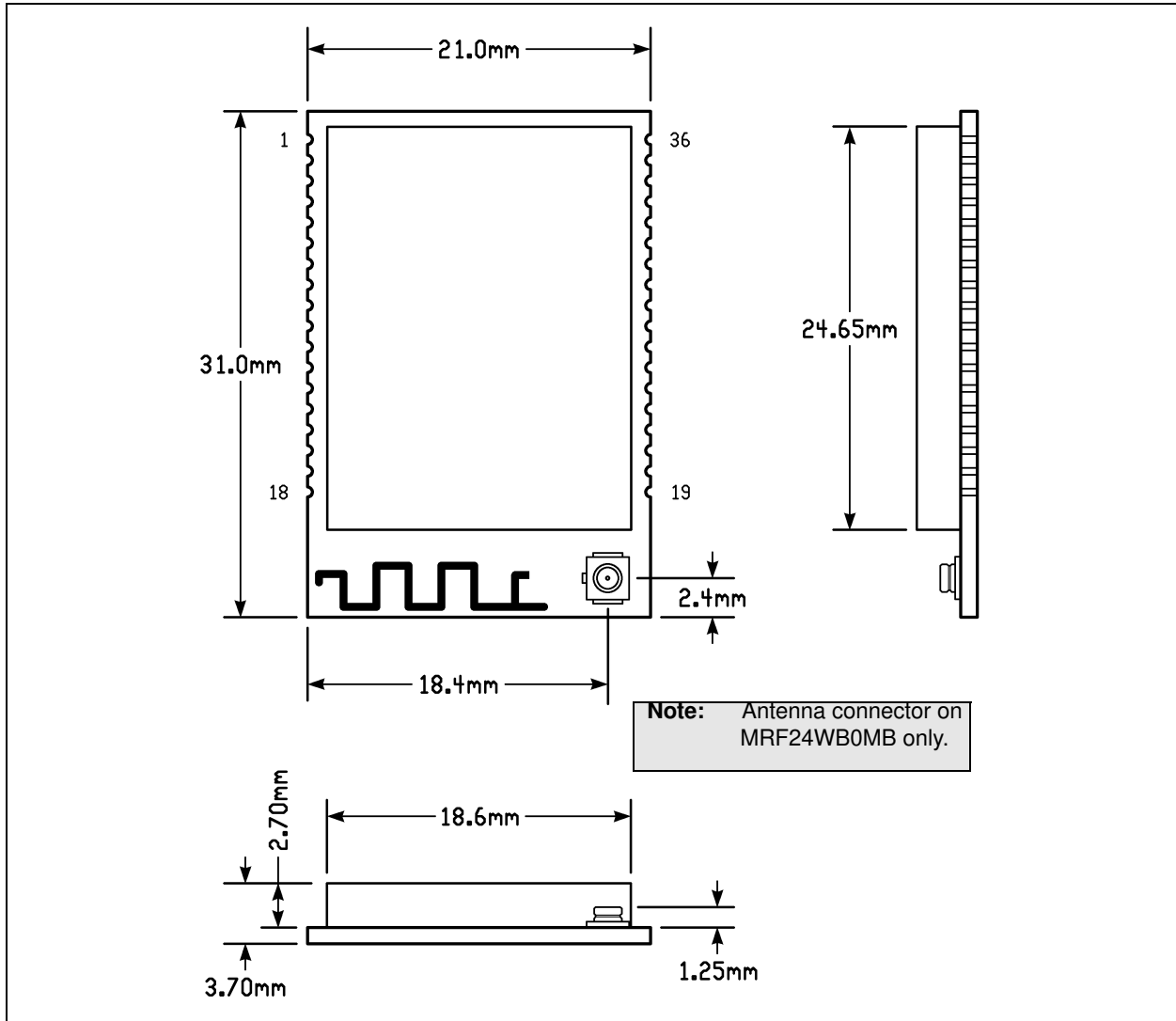

# MRF24WB0MA/MRF24WB0MB

The MRF24WB0MA has an integrated PCB antenna. For best performance, mount the module on the PCB without metal obstructions in the keep out area. The antenna is tuned to have FR4 PCB material

underneath the module. Do not “cut-out” host PCB material under the antenna. Figure 1-4 shows the recommended host PCB footprint for the module.

**FIGURE 1-4: RECOMMENDED HOST PCB FOOTPRINT**

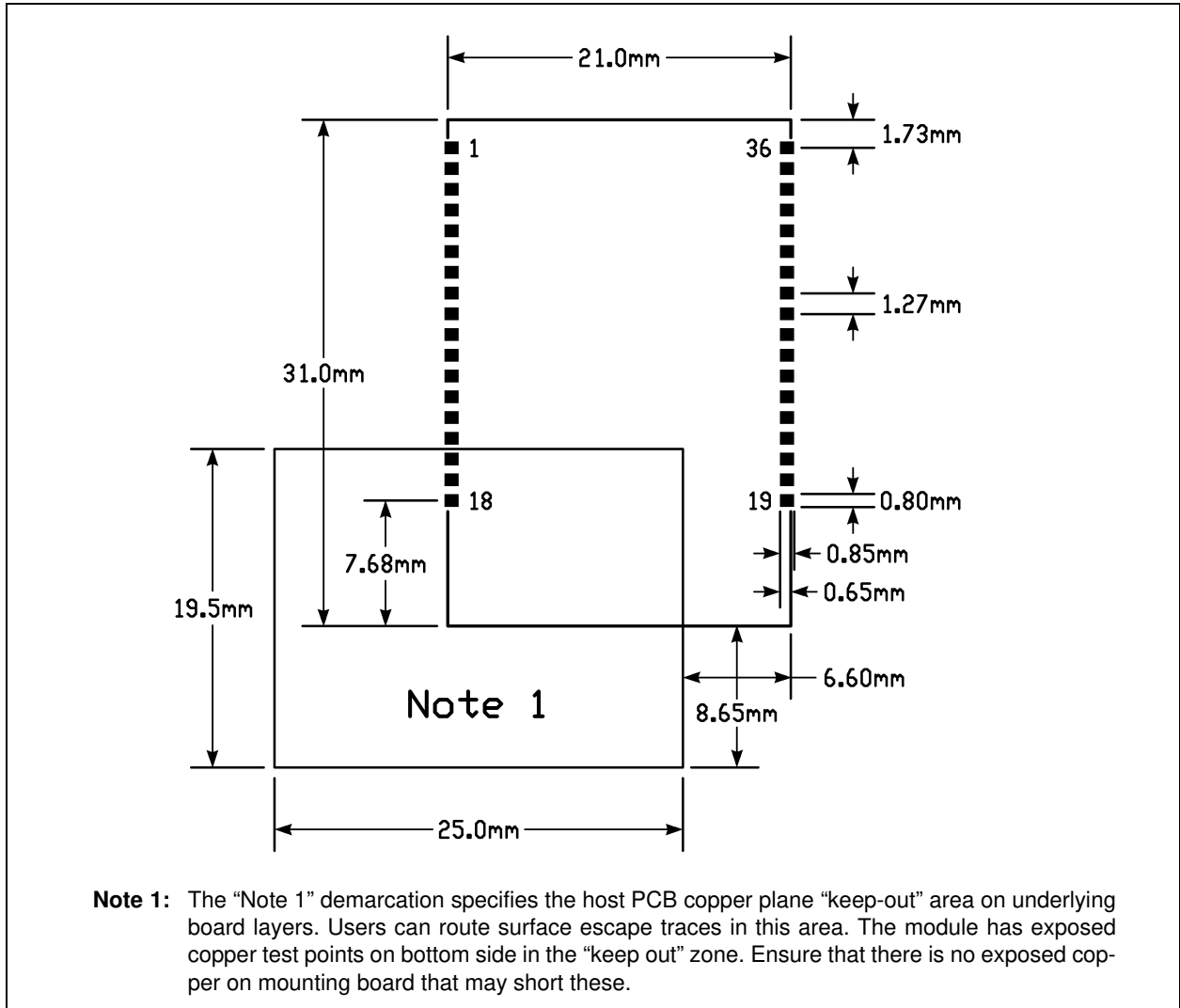

# MRF24WB0MA/MRF24WB0MB

Figure 1-5 illustrates the module reflow profile that is recommended for mounting the device onto the host PCB.

**FIGURE 1-5: RECOMMENDED MODULE REFLOW PROFILE AND SETPOINTS**

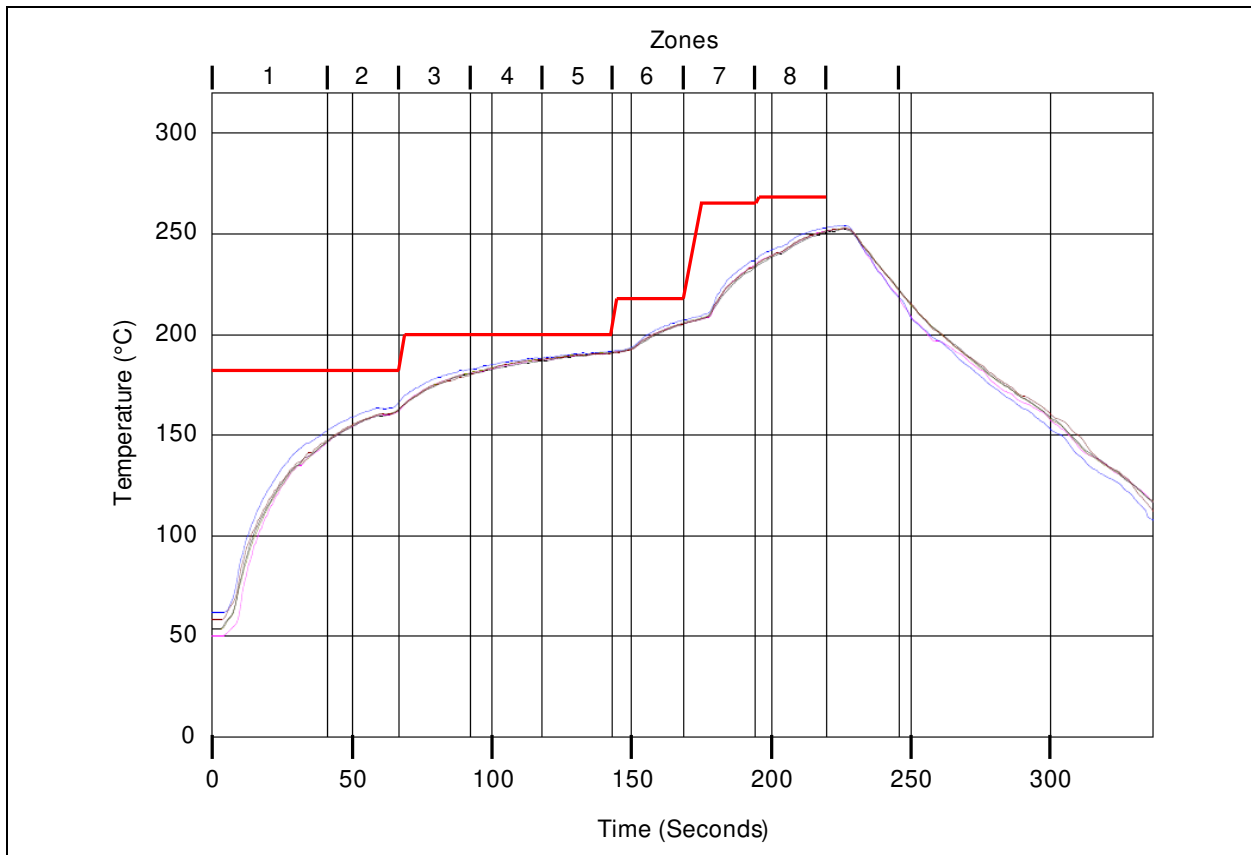

The following table lists the module re-flow profile

**TABLE 1-2: MODULE RE-FLOW PROFILE<sup>(1)</sup>**

Zone	1	2	3	4	5	6	7	8
Temperature (°C)	180°	180°	200°	200°	200°	220°	265°	270°

**Note 1:** Conveyor Speed: 90 cm/min.

details.



# MRF24WB0MA/MRF24WB0MB

FIGURE 2-2: MRF24WB0MA/MRF24WB0MB POWER-ON SEQUENCE TIMING

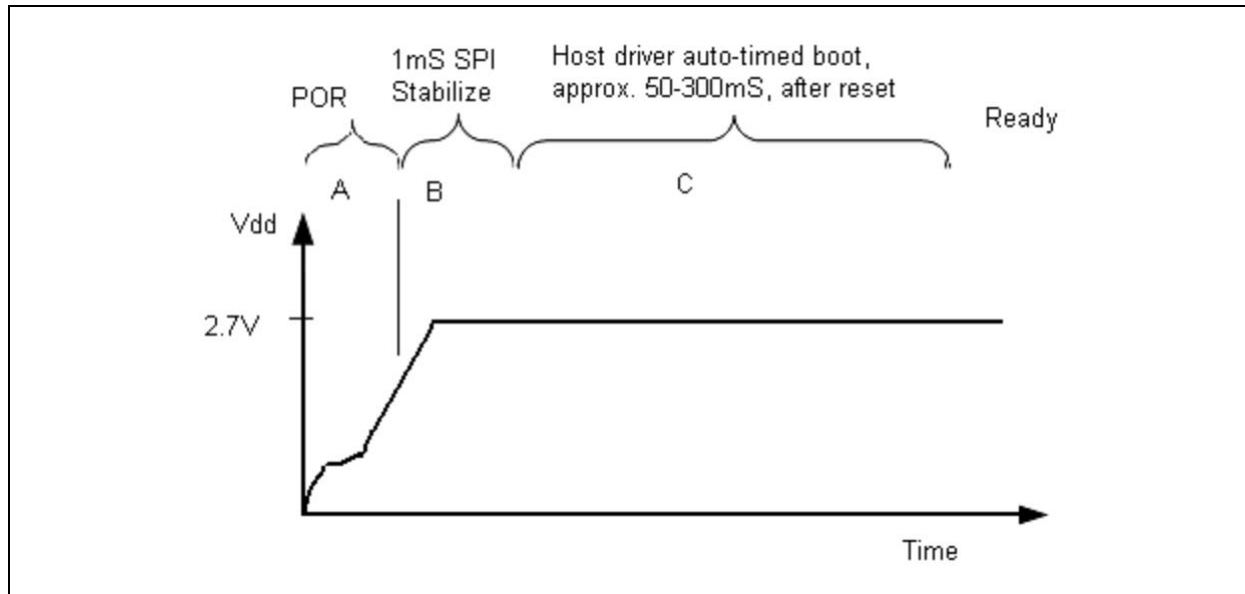

# MRF24WB0MA/MRF24WB0MB

## 2.3 Power States

The MRF24WB0MA/MRF24WB0MB has the following power states: Hibernate, Sleep and Active (two sub-states), as shown in Figure 2.4. The selection of power

state affects system behavior, and overall power consumption or battery life. Addition to that there is one “Standby” state that is not user-controlled.

**FIGURE 2-3: MRF24WB0MA/MRF24WB0MB POWER-STATE DIAGRAM**

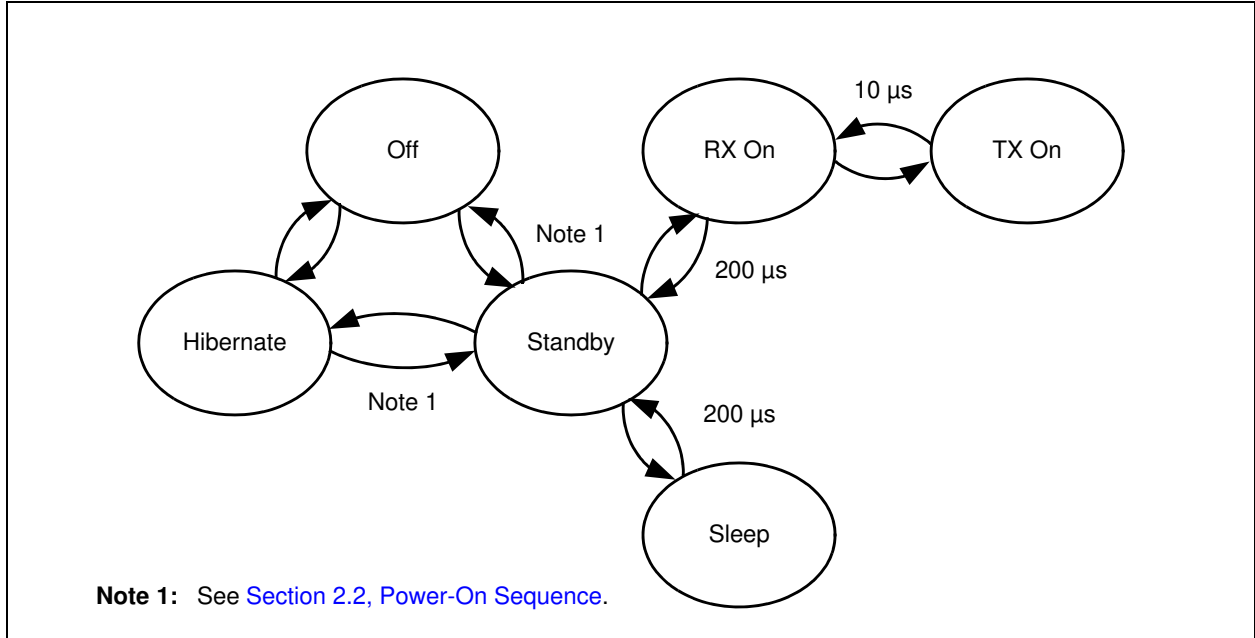

### 2.3.1 HIBERNATE STATE

An “Off” state is defined as no power applied to the device. The Hibernate mode is the closest to controlled off that the module can approach. It is controlled through the HIBERNATE pin (high input puts the module into Hibernate). When in Hibernate, the module only consumes leakage current, but does not maintain state. Hibernate has to be fully controlled by the PIC MCU and requires the TCP/IP stack to restart on an awake.

The module contains about 70μF of internal bulk capacitance. Supplies should be provisioned to supply sufficient charge on release of hibernate for required start time or sufficient delay must be provided in software after hibernate release and before Reset release.

This state provides the best battery life for embedded products. Entering Hibernate for intervals of less than 30 seconds is not likely to save power. Battery life expectation can be more than a year for devices operating on AA cells that is in Hibernate except to wake up every hour for a small data transfer (<500 Bytes).

### 2.3.2 SLEEP STATE

The Sleep state is a low power dynamic state that implements the 802.11 Power Save feature. In this mode, if enabled, the module will enter Power Save mode when all activity is complete.

The module will wake autonomously to any PIC intervention to check DTIM beacons from the Access Point (AP). If any traffic is listed as queued for the module, then it will awaken and get the data from the AP on the next possible opportunity. When data is acquired, the module will interrupt the PIC microcontroller on a normal “data available” indication. If no data is available on a DTIM check, the module reenters the Power Save state until the next DTIM. The DTIM interval is programmed at the AP. This state can provide “as if on” behavior of the radio with a significant power savings versus “always on”. The battery life expectation of this mode is several days to several weeks. This mode is characterized by a very-low latency (as low as 200 mS) to begin data transfer from the low-power state.

### 2.3.3 ACTIVE STATE

The Active state is identified as one of the two states where the radio circuitry is fully on. The two active states are the Receive state (RX ON) and Transmit state (TX ON).

# MRF24WB0MA/MRF24WB0MB

---

## 2.3.4 STANDBY STATE

The Standby state is not user-controlled, but it is noted as it helps identify and track certain operations of the module during power tracing.

**TABLE 2-1: MRF24WB0MA/MRF24WB0MB POWER STATE DEFINITIONS**

State	VDD	Hibernate	Description
Off	0V	0V	Power is disconnected
Hibernate	3.3V	3.3V	All internal power regulators are OFF – enabled by HIBERNATE pin
Sleep	3.3V	0V	Enabled by TCP/IP driver
RX ON	3.3V	0V	Receive circuits are ON and receiving
TX ON	3.3V	0V	Transmit circuits are ON and transmitting
Standby	3.3V	0V	State machine transition state only – not user controlled

# MRF24WB0MA/MRF24WB0MB

## 2.4 JTAG Interface

Joint Test Action Group (JTAG) is the common name used for IEEE 1149.1 entitled Standard Test Access Port and Boundary-Scan Architecture for test access ports that are used for testing printed circuit boards using boundary scan. The MRF24WB0MA/MRF24WB0MB supports JTAG boundary scan. The JTAG port provides the optional hardware JTAG Reset input, JTAGRST. JTAG\_EN and JTAGRST need to be driven high to enable JTAG mode. JTAG should not be enabled during normal functional operation which affects power state current.

## 2.5 Debug Serial Interface

The MRF24WB0MA/MRF24WB0MB incorporates a Transmit Data pin (DEBUGTX) and a Receive Data pin (DEBUGRX) for serial debugging purposes. These pins can be connected to commercially available RS-232 line drivers/receivers with appropriate external level shifters. The serial interface operates at 19200, 8, N, 1, N.

## 2.6 SPI Interface

The slave Serial Peripheral Interface (SPI) is used to interface with the host PIC microcontroller. The slave SPI interface works with the Interrupt line ( $\overline{\text{INT}}$ ). When data is available for the PIC microcontroller during operation, the  $\overline{\text{INT}}$  line is asserted (logic low) by the MRF24WB0MA/MRF24WB0MB module. The  $\overline{\text{INT}}$  line is de-asserted (logic high) by the MRF24WB0MA/MRF24WB0MB after the data is transferred to the host PIC microcontroller. The SPI SCK frequency can be up to 25 MHz.

The slave SPI interface implements the [CPOL = 0; CPHA = 0] and [CPOL = 1; CPHA = 1] modes (0 and 3) of operation. That is, data is clocked in on the first rising edge of the clock after Chip Select ( $\overline{\text{CS}}$ ) is asserted. Data is placed on the bus with most significant bit (MSb) first.

The  $\overline{\text{CS}}$  pin must be toggled with transfer blocks and cannot be held low permanently. The falling edge of  $\overline{\text{CS}}$  is used to indicate the start of a transfer. The rising edge of  $\overline{\text{CS}}$  is used to indicate the completion of a transfer.

Figure 4-1 in Section 4.0, Electrical Characteristics shows the SPI timing diagram. Table 4-7 details the SPI timing AC characteristics.

## 2.7 PCB Antenna

For MRF24WB0MA, the PCB antenna is fabricated on the top copper layer and covered in solder mask. The layers below the antenna have no copper trace.

It is recommended that the module be mounted on the edge of the host PCB. It is permitted for PCB material to be below the antenna structure of the module as long as no copper traces or planes are on the host PCB in that area. For best performance, place the module on the host PCB according to the details shown in Figure 1-4.

Figure 2-4, Figure 2-5 and Figure 2-6 show the antenna and simulated radiation patterns expected from the PCB antenna. Refer to three separate axis of measurement that corresponds to the orientation of the module (drawn in the center of each plot).

The horizontal and vertical data, blue and red, in each plot correspond to the orientation (polarization) of the measurement antenna rotated 360 degrees around the module.

The horizontal measurement was done with the receive antenna parallel to the module PCB. The vertical measurement was done perpendicular to the module PCB.

These patterns allow the designer to understand the performance of the module with respect to the position of the receive or transmit antenna at the other end of the link.



# MRF24WB0MA/MRF24WB0MB

FIGURE 2-4: AZIMUTH RADIATION PATTERN, 2.44 GHz

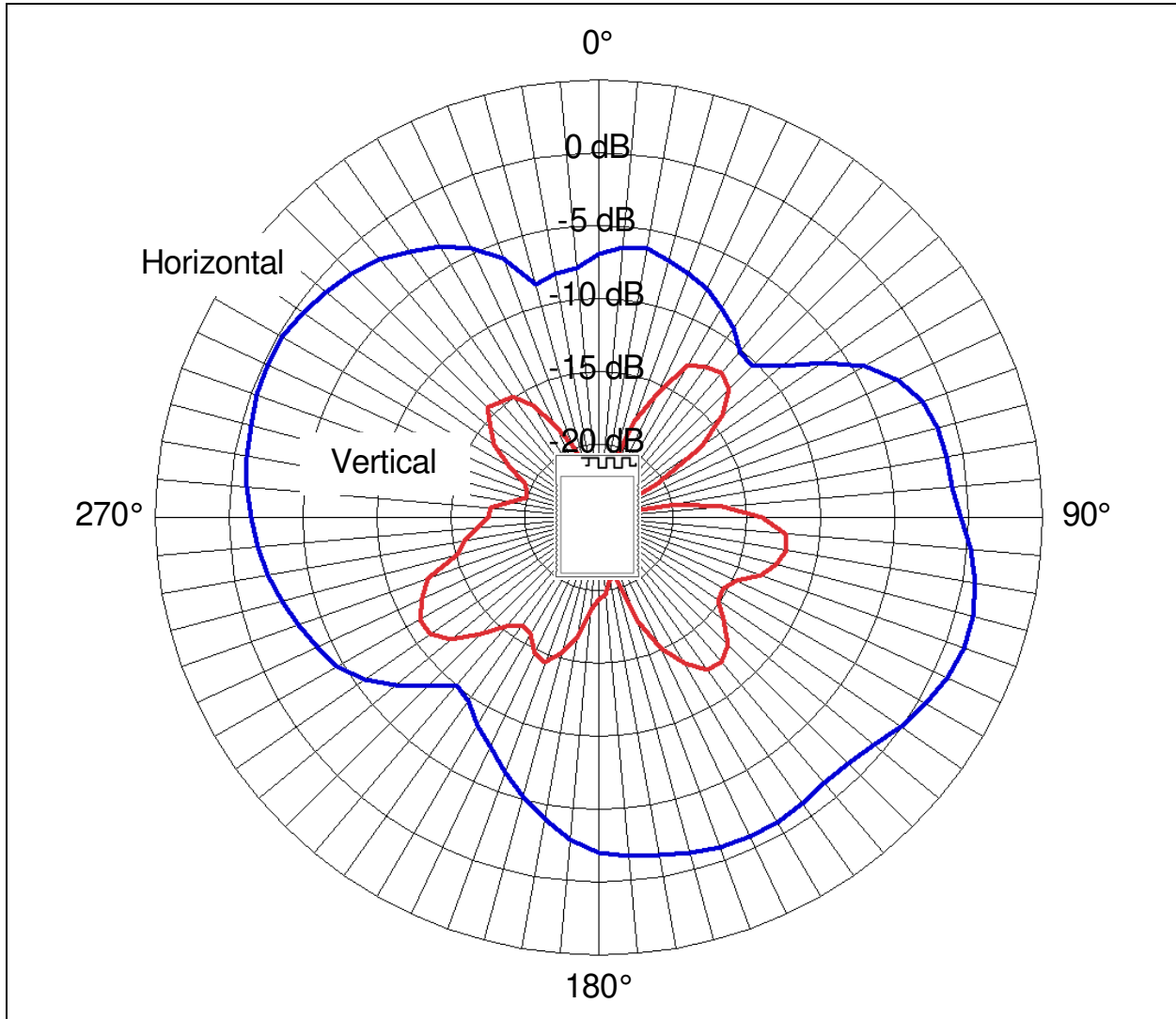

# MRF24WB0MA/MRF24WB0MB

FIGURE 2-5: RADIATION PATTERN ON SIDE WITH PCB ANTENNA, 2.44 GHz

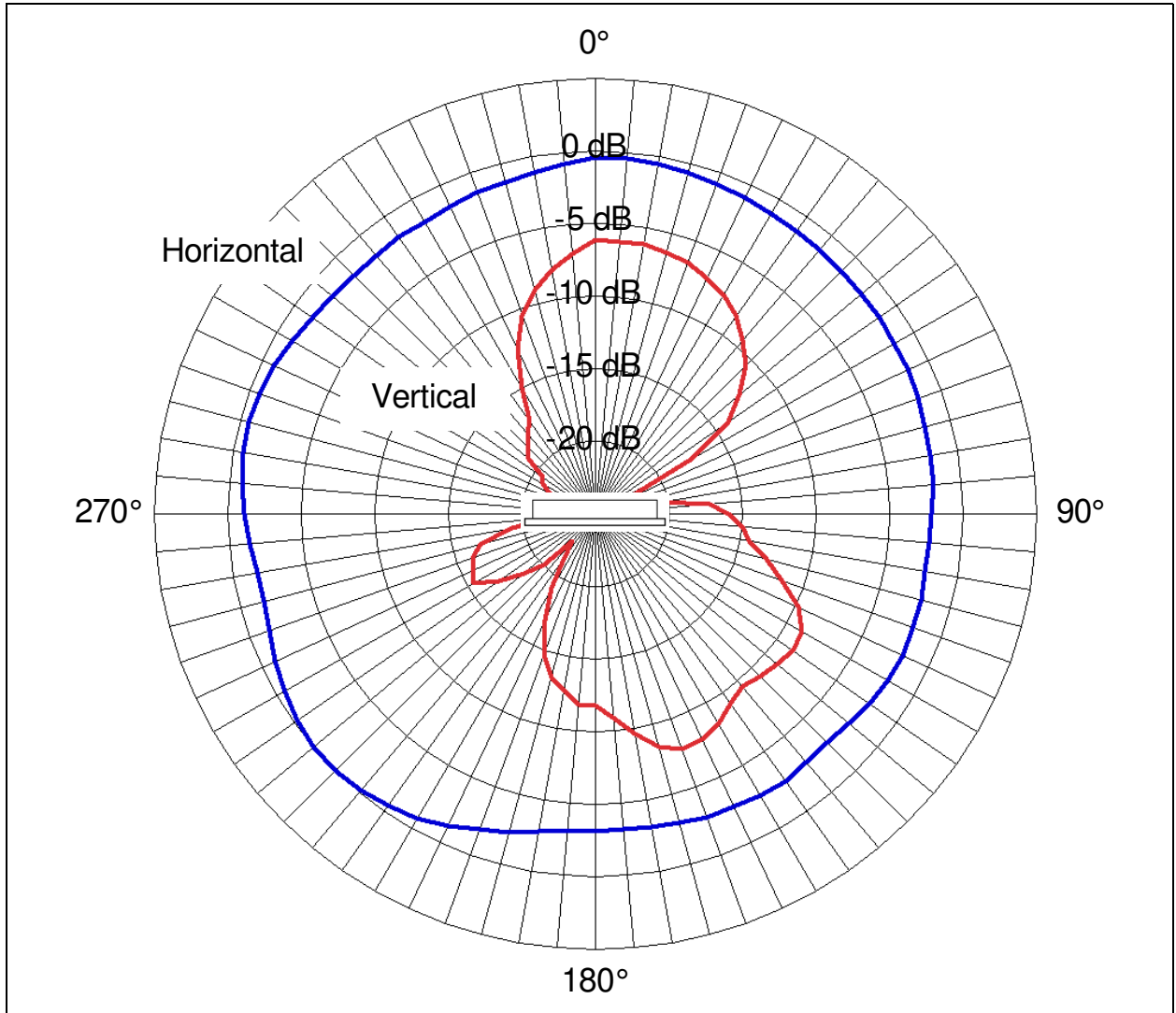

# MRF24WB0MA/MRF24WB0MB

FIGURE 2-6: RADIATION PATTERN ALONG PIN EDGE, 2.44 GHz

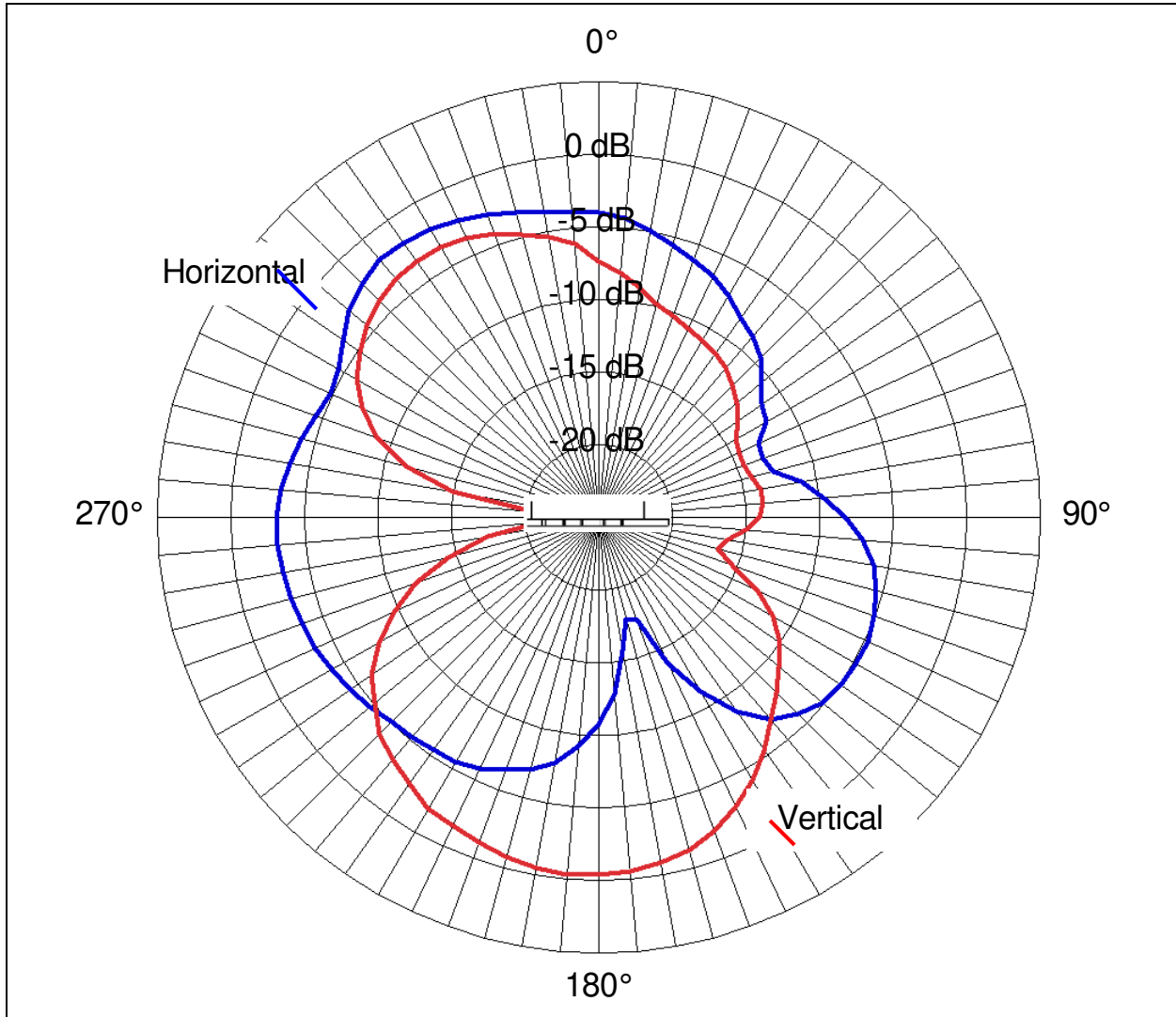

# MRF24WB0MA/MRF24WB0MB

## 2.8 External Antenna

The choice of an external antenna is limited to the antenna types the module is tested with. Refer to [Section 3.0, Regulatory Approval](#) for specific country-wise regulatory requirements.

A list of antennas types tested with the MRF24WB0MB modules is provided in [Table 2-2](#).

**TABLE 2-2: TESTED EXTERNAL ANTENNA TYPES**

Part Number	Type	Gain (dBi)	VSWR Max.	Connector	Vendor
RFA-02-P05	PCB	2	2.0	IPEX	Aristotle
RFA-02-L6H1-70-35	Dipole	2	2.0	IPEX	Aristotle
RFA-02-D3	Dipole	1.5	2.0	IPEX	Aristotle
RFA-02-L2H1	Dipole	2	2.0	IPEX	Aristotle
RFA-02-3-C5H1	Dipole	3	2.0	IPEX	Aristotle
RFA-02-5-C7H1	Dipole	5	2.0	IPEX	Aristotle
RFA-02-5-F7H1	Dipole	5	2.0	IPEX	Aristotle
WF2400-15001A	Dipole	5	2.0	IPEX	Saytec
WF2400-15001AR	Dipole	5	2.0	RF-IPEX	Saytec
WF2400-10001I	Dipole	2	2.0	IPEX	Saytec
WF2400-10001R	Dipole	2	2.0	RF-IPEX	Saytec
AN2400-5901RS, used with connector SMASFR8-3152H-00X00I	Omni	9	2.0	IPEX	Saytec
AN2400-5901RS, used with connector SMASFR8-3152H-00X00IR	Omni	9	2.0	RF-IPEX	Saytec

# MRF24WB0MA/MRF24WB0MB

---

---

NOTES:

# MRF24WB0MA/MRF24WB0MB

## 3.0 REGULATORY APPROVAL

This section outlines the regulatory information for the MRF24WB0MA/MRF24WB0MB module for the following countries:

- United States
- Canada
- Europe
- Australia
- New Zealand
- Korea
- Other

### 3.1 United States

The MRF24WB0MA/MRF24WB0MB module has received Federal Communications Commission (FCC) CFR47 Telecommunications, Part 15 Subpart C “Intentional Radiators” modular approval in accordance with Part 15.212 Modular Transmitter approval. Modular approval allows the end user to integrate the MRF24WB0MA/MRF24WB0MB module into a finished product without obtaining subsequent and separate FCC approvals for intentional radiation, provided no changes or modifications are made to the module circuitry. Changes or modifications could void the user’s authority to operate the equipment. The end user must comply with all of the instructions provided by the Grantee, which indicate installation and/or operating conditions necessary for compliance.

The finished product is required to comply with all applicable FCC equipment authorizations regulations, requirements and equipment functions not associated with the transmitter module portion. For example, compliance must be demonstrated to regulations for other transmitter components within the host product; to requirements for unintentional radiators (Part 15 Subpart B “Unintentional Radiators”), such as digital devices, computer peripherals, radio receivers, etc; and to additional authorization requirements for the non-transmitter functions on the transmitter module (i.e., Verification, or Declaration of Conformity) (e.g., transmitter modules may also contain digital logic functions) as appropriate.

#### 3.1.1 LABELING AND USER INFORMATION REQUIREMENTS

The MRF24WB0MA/MRF24WB0MB module is labeled with its own FCC ID number. If the FCC ID is not visible when the module is installed inside another device, then the outside of the finished product into which the module is installed must display a label referring to the enclosed module.

This exterior label can use wording as follows:

Contains Transmitter Module FCC ID:  
W7OZG2100-ZG2101

or

Contains FCC ID: W7OZG2100-ZG2101

This device complies with Part 15 of the FCC Rules. Operation is subject to the following two conditions:

(1) this device may not cause harmful interference, and (2) this device must accept any interference received, including interference that may cause undesired operation.

A user’s manual for the product should include the following statement:

This equipment has been tested and found to comply with the limits for a Class B digital device, pursuant to part 15 of the FCC Rules. These limits are designed to provide reasonable protection against harmful interference in a residential installation. This equipment generates, uses and can radiate radio frequency energy, and if not installed and used in accordance with the instructions, may cause harmful interference to radio communications. However, there is no guarantee that interference will not occur in a particular installation. If this equipment does cause harmful interference to radio or television reception, which can be determined by turning the equipment off and on, the user is encouraged to try to correct the interference by one or more of the following measures:

- Reorient or relocate the receiving antenna.
- Increase the separation between the equipment and receiver.
- Connect the equipment into an outlet on a circuit different from that to which the receiver is connected.
- Consult the dealer or an experienced radio/TV technician for help.

Additional information on labeling and user information requirements for Part 15 devices can be found in KDB Publication 784748 available at the FCC Office of Engineering and Technology (OET) Laboratory Division Knowledge Database (KDB), <http://apps.fcc.gov/oetcf/kdb/index.cfm>.

# MRF24WB0MA/MRF24WB0MB

## 3.1.2 RF EXPOSURE

All transmitters regulated by FCC must comply with RF exposure requirements. OET Bulletin 65, *Evaluating Compliance with FCC Guidelines for Human Exposure to Radio Frequency Electromagnetic Fields*, provides assistance in determining whether proposed or existing transmitting facilities, operations or devices comply with limits for human exposure to Radio Frequency (RF) fields adopted by the Federal Communications Commission (FCC). The bulletin offers guidelines and suggestions for evaluating compliance.

If appropriate, compliance with exposure guidelines for mobile and unlicensed devices can be accomplished by the use of warning labels and by providing users with information concerning minimum separation distances from transmitting structures and proper installation of antennas.

The following statement must be included as a caution statement in manuals and OEM products to alert users of FCC RF exposure compliance:

To satisfy FCC RF Exposure requirements for mobile and base station transmission devices, a separation distance of 20 cm or more should be maintained between the antenna of this device and persons during operation. To ensure compliance, operation at closer than this distance is not recommended.

The antenna(s) used for this transmitter must not be co-located or operating in conjunction with any other antenna or transmitter.

If the MRF24WB0MA/MRF24WB0MB module is used in a portable application (i.e., the antenna is less than 20 cm from persons during operation), the integrator is responsible for performing Specific Absorption Rate (SAR) testing in accordance with FCC rules 2.1091.

## 3.1.3 APPROVED EXTERNAL ANTENNA TYPES

To maintain modular approval in the United States, only tested antenna types must be used. It is permissible to use different manufacturer antenna provided the same antenna type and antenna gain (equal to or less than) is used.

MRF24WB0MB module testing was performed with the antenna types listed in [Table 2-2](#) in [Section 2.8, External Antenna](#).

## 3.1.4 HELPFUL WEB SITES

Federal Communications Commission (FCC):  
<http://www.fcc.gov>.

FCC Office of Engineering and Technology (OET)  
Laboratory Division Knowledge Database (KDB):  
<http://apps.fcc.gov/oetcf/kdb/index.cfm>.

## 3.2 Canada

The MRF24WB0MA/MRF24WB0MB module is certified for use in Canada under Industry Canada (IC) Radio Standards Specification (RSS) RSS-210 and RSSGen. Modular approval permits the installation of a module in a host device without the need to recertify the device.

### 3.2.1 LABELING AND USER INFORMATION REQUIREMENTS

Labeling requirements for the Host Device (from Section 3.2.1, RSS-Gen, Issue 3, December 2010): The host device must be labeled to identify the module within the host device.

The Industry Canada certification label of a module must be clearly visible at all times when installed in the host device, otherwise the host device must be labeled to display the Industry Canada certification number of the module, preceded by the words "Contains transmitter module", or the word "Contains", or similar wording expressing the same meaning, as follows:

Contains transmitter module IC:  
8248A-G21ZEROG

User Manual Notice for License-Exempt Radio Apparatus (from Section 7.1.3, RSS-Gen, Issue 3, December 2010): User manuals for license-exempt radio apparatus must contain the following or equivalent notice in a conspicuous location in the user manual or alternatively on the device or both:

This device complies with Industry Canada license-exempt RSS standard(s). Operation is subject to the following two conditions: (1) this device may not cause interference, and (2) this device must accept any interference, including interference that may cause undesired operation of the device.

Le présent appareil est conforme aux CNR d'Industrie Canada applicables aux appareils radio exempts de licence. L'exploitation est autorisée aux deux conditions suivantes: (1) l'appareil ne doit pas produire de brouillage, et (2) l'utilisateur de l'appareil doit accepter tout brouillage radioélectrique subi, même si le brouillage est susceptible d'en compromettre le fonctionnement.

# MRF24WB0MA/MRF24WB0MB

Transmitter Antenna (from Section 7.1.2, RSS-Gen, Issue 3, December 2010): User manuals for transmitters must display the following notice in a conspicuous location:

Under Industry Canada regulations, this radio transmitter may only operate using an antenna of a type and maximum (or lesser) gain approved for the transmitter by Industry Canada. To reduce potential radio interference to other users, the antenna type and its gain should be so chosen that the equivalent isotropically radiated power (e.i.r.p.) is not more than that necessary for successful communication.

Conformément à la réglementation d'Industrie Canada, le présent émetteur radio peut fonctionner avec une antenne d'un type et d'un gain maximal (ou inférieur) approuvé pour l'émetteur par Industrie Canada. Dans le but de réduire les risques de brouillage radioélectrique à l'intention des autres utilisateurs, il faut choisir le type d'antenne et son gain de sorte que la puissance isotrope rayonnée équivalente (p.i.r.e.) ne dépasse pas l'intensité nécessaire à l'établissement d'une communication satisfaisante.

The above notice may be affixed to the device instead of displayed in the user manual.

User manuals for transmitters equipped with detachable antennas shall also contain the following notice in a conspicuous location:

This radio transmitter (identify the device by certification number, or model number if Category II) has been approved by Industry Canada to operate with the antenna types listed below with the maximum permissible gain and required antenna impedance for each antenna type indicated. Antenna types not included in this list, having a gain greater than the maximum gain indicated for that type, are strictly prohibited for use with this device.

Conformément à la réglementation d'Industrie Canada, le présent émetteur radio peut fonctionner avec une antenne d'un type et d'un gain maximal (ou inférieur) approuvé pour l'émetteur par Industrie Canada. Dans le but de réduire les risques de brouillage radioélectrique à l'intention des autres utilisateurs, il faut choisir le type d'antenne et son gain de sorte que la puissance isotrope rayonnée équivalente (p.i.r.e.) ne dépasse pas l'intensité nécessaire à l'établissement d'une communication satisfaisante.

After the preceding notice, the manufacturer must provide a list of all antenna types approved for use with the transmitter, indicating the maximum permissible antenna gain (in dBi) and required impedance for each.

## 3.2.2 APPROVED EXTERNAL ANTENNA TYPES

Transmitter Antenna (from Section 7.1.2 RSS-Gen, Issue 3, December 2010):

The MRF24WB0MA/MRF24WB0MB module can only be sold or operated with antennas with which it was approved. Transmitter may be approved with multiple antenna types. An antenna type comprises antennas having similar in-band and out-of-band radiation patterns. Testing shall be performed using the highest gain antenna of each combination of transmitter and antenna type for which approval is being sought, with the transmitter output power set at the maximum level. Any antenna of the same type having equal or lesser gain as an antenna that had been successfully tested with the transmitter, will also be considered approved with the transmitter, and may be used and marketed with the transmitter.

When a measurement at the antenna connector is used to determine RF output power, the effective gain of the device's antenna shall be stated, based on measurement or on data from the antenna manufacturer. For transmitters of output power greater than 10 milliwatts, the total antenna gain shall be added to the measured RF output power to demonstrate compliance to the specified radiated power limits.

Approved external antenna types for the MRF24WB0MB module are listed in [Table 2-2](#) in [Section 2.8, External Antenna](#).

## 3.2.3 HELPFUL WEB SITES

Industry Canada: <http://www.ic.gc.ca/>.

## 3.3 Europe

The MRF24WB0MA/MRF24WB0MB module is an R&TTE Directive assessed radio module that is CE marked, and manufactured and tested with the intention of being integrated into a final product.

The MRF24WB0MA/MRF24WB0MB module tested to R&TTE Directive 1999/5/EC Essential Requirements for Health and Safety (Article (3.1(a)), Electromagnetic Compatibility (EMC) (Article 3.1(b)), and Radio (Article 3.2) and are summarized in [Table 3-1](#). A Notified Body Opinion has also been issued. All test reports are available on the MRF24WB0MA/MRF24WB0MB product web page at <http://www.microchip.com>.

The R&TTE Compliance Association provides guidance on modular devices in the document "*Technical Guidance Note 01*", which is available at [http://www.rteca.com/html/download\\_area.htm](http://www.rteca.com/html/download_area.htm).



# MRF24WB0MA/MRF24WB0MB

**Note:** To maintain conformance to the testing listed in [Table 3-1](#): European Compliance Testing, the module shall be installed in accordance with the installation instructions in this data sheet and shall not be modified.

When integrating a radio module into a completed product the integrator becomes the manufacturer of the final product and is therefore responsible for demonstrating compliance of the final product with the essential requirements of the R&TTE Directive.

## 3.3.1 LABELING AND USER INFORMATION REQUIREMENTS

The label on the final product which contains the MRF24WB0MA/MRF24WB0MB module must follow CE marking requirements. The R&TTE Compliance Association document “*Technical Guidance Note 01*” provides guidance on final product CE marking.

## 3.3.2 EXTERNAL ANTENNA REQUIREMENTS

From the R&TTE Compliance Association document Technical Guidance Note 01:

Provided the integrator installing an assessed radio module with an integral or specific antenna and installed in conformance with the radio module manufacturer’s installation instructions requires no further evaluation under Article 3.2 of the R&TTE Directive and

does not require further involvement of an R&TTE Directive Notified Body for the final product. See [Section 2.3.4, Standby State](#).

The European Compliance Testing listed in [Table 3-1](#) was performed using the antenna types listed in [Section 2.8, External Antenna](#).

## 3.3.3 HELPFUL WEB SITES

A document that can be used as a starting point in understanding the use of Short Range Devices (SRD) in Europe is the European Radio Communications Committee (ERC) Recommendation 70-03 E, which can be downloaded from the European Radio Communications Office (ERO) at: <http://www.ero.dk/>.

Additional helpful web sites are:

- Radio and Telecommunications Terminal Equipment (R&TTE):

[http://ec.europa.eu/enterprise/rtte/index\\_en.htm](http://ec.europa.eu/enterprise/rtte/index_en.htm)

- European Conference of Postal and Telecommunications Administrations (CEPT):

<http://www.cept.org>

- European Telecommunications Standards Institute (ETSI):

<http://www.etsi.org>

- European Radio Communications Office (ERO):

<http://www.ero.dk>

**TABLE 3-1: EUROPEAN COMPLIANCE TESTING**

Certification	Standards	Article	Laboratory	Report Number	Date
Safety	IEC 60950-1:2001	(3.1(a))	TUV Rheinland	30883573.001	2009-03-11
EMC	EN 301 489-1 V1.8.1 (2008-04)	(3.1(b))		30853571.004	2009-03-16
	EN 301 489-17 V1.2.1 (2002-04)				
Radio	EN 300 328 V1.7.1 (2006-10)	(3.2)		30853571.003	2009-04-28

## 3.4 Australia

The Australia radio regulations do not provide a modular approval policy similar to the United States (FCC) and Canada (IC). However, MRF24WB0MA/MRF24WB0MB module RF transmitter test reports can be used in part to demonstrate compliance in accordance with ACMA Radio communications “Short Range Devices” Standard 2004 (The Short Range Devices standard calls up the AS/NZS 4268:2008 industry standard). The MRF24WB0MA/MRF24WB0MB module test reports can be used as part of the product certification and compliance folder. For more information on the RF transmitter test reports, contact Microchip Technology Australia sales office.

To meet overall Australian final product compliance, the developer must construct a compliance folder containing all relevant compliance test reports, for example RF, EMC, electrical safety and Declaration of

Conformity (DoC) and so on. Integrator must know what is required in the compliance folder for ACMA compliance. All test reports are available on the MRF24WB0MA/MRF24WB0MB product web page at <http://www.microchip.com>. For more information on Australia compliance, refer to the Australian Communications and Media Authority web site <http://www.acma.gov.au/>.

## 3.4.1 EXTERNAL ANTENNA REQUIREMENTS

The compliance testing listed in [Table 3-1](#) was performed using the antenna types listed in [Table 2-2](#) in [Section 2.8, External Antenna](#).

## 3.4.2 HELPFUL WEB SITES

The Australian Communications and Media Authority: <http://www.acma.gov.au/>.

# MRF24WB0MA/MRF24WB0MB

## 3.5 New Zealand

The New Zealand radio regulations do not provide a modular approval policy similar to the United States (FCC) and Canada (IC). However, MRF24WB0MA/MRF24WB0MB module RF transmitter test reports can be used in part to demonstrate compliance against the New Zealand “General User Radio License for Short Range Devices”. New Zealand Radio communications (Radio Standards) Notice 2010 calls up the AS/NZS 4268:2008 industry standard. The MRF24WB0MA/MRF24WB0MB module test reports can be used as part of the product certification and compliance folder. All test reports are available on the MRF24WB0MA/MRF24WB0MB product web page at <http://www.microchip.com>. For more information on the RF transmitter test reports, contact Microchip Technology sales office.

Information on the New Zealand short range devices license can be found in the following web sites:

<http://www.rsm.govt.nz/cms/licensees/types-of-licence/general-user-licences/short-range-devices>.

and

<http://www.rsm.govt.nz/cms/policy-and-planning/spectrum-policy-overview/legislation/gazette-notices/product-compliance/radiocommunications-radiostandards-notice-2010>.

To meet overall New Zealand final product compliance, the developer must construct a compliance folder with all relevant compliance test reports, for example RF, EMC, electrical safety and DoC (Declaration of Conformity) etc. The developer must know what is required in the compliance folder for New Zealand Radio communications. For more information on New Zealand compliance, refer to the web site <http://www.rsm.govt.nz/>.

### 3.5.1 EXTERNAL ANTENNA REQUIREMENTS

The compliance testing listed in [Table 3-1](#) was performed using the antenna types listed in [Table 2-2](#) in [Section 2.8, External Antenna](#).

### 3.5.2 HELPFUL WEB SITES

Radio Spectrum Ministry of Economic Development:  
<http://www.rsm.govt.nz/>.

## 3.6 Korea

The MRF24WB0MA/MRF24WB0MB module has received certification of conformity in accordance with the Radio Waves Act. Integration of this module into a final product does not require additional radio certification provided installation instructions are followed and no modifications of the module are allowed.

### 3.6.1 LABELING AND USER INFORMATION REQUIREMENTS

The label on the final product which contains the MRF24WB0MA/MRF24WB0MB module must follow KC marking requirements. The integrator of the module should refer to the labeling requirements for Korea available on the Korea Communications Commission (KCC) web site.

The MRF24WB0MA/MRF24WB0MB module is labeled with its own KC mark. The final product requires the KC mark and certificate number of the module:



### 3.6.2 EXTERNAL ANTENNA REQUIREMENTS

The Korea compliance testing was performed using the antenna types listed in [Table 2-2](#) in [Section 2.8, External Antenna](#).

### 3.6.3 HELPFUL WEB SITES

Korea Communications Commission (KCC):  
<http://www.kcc.go.kr>.

National Radio Research Agency (RRA):  
<http://rra.go.kr>.

## 3.7 Other Regulatory Jurisdictions

Other regulatory jurisdiction certification must be required by the customer, or the customer need to recertify the module for other reasons, a certification utility is available. The utility runs on a Window's PC and utilizes a USB to SPI converter to interface to the MRF24WB0M module. To use the utility, the MRF24WB0M module must be out of Reset and not accessed by the system host. That is, the SPI signals to the MRF24WB0M must be tri-state, with Reset and Hibernate deasserted. The following signals will need to be brought from the MRF24WB0M for connection to the PC (through the USB adapter):

- SDO
- SDI
- $\overline{CS}$
- SCK
- $\overline{INT}$
- GND

For further regulatory Certification Utility and documentation, contact local Microchip sales office.