



Chipsmall Limited consists of a professional team with an average of over 10 year of expertise in the distribution of electronic components. Based in Hongkong, we have already established firm and mutual-benefit business relationships with customers from,Europe,America and south Asia,supplying obsolete and hard-to-find components to meet their specific needs.

With the principle of “Quality Parts,Customers Priority,Honest Operation,and Considerate Service”,our business mainly focus on the distribution of electronic components. Line cards we deal with include Microchip,ALPS,ROHM,Xilinx,Pulse,ON,Everlight and Freescale. Main products comprise IC,Modules,Potentiometer,IC Socket,Relay,Connector.Our parts cover such applications as commercial,industrial, and automotives areas.

We are looking forward to setting up business relationship with you and hope to provide you with the best service and solution. Let us make a better world for our industry!



Contact us

Tel: +86-755-8981 8866 Fax: +86-755-8427 6832

Email & Skype: info@chipsmall.com Web: www.chipsmall.com

Address: A1208, Overseas Decoration Building, #122 Zhenhua RD., Futian, Shenzhen, China



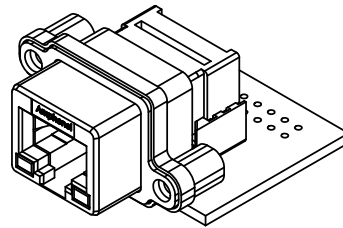
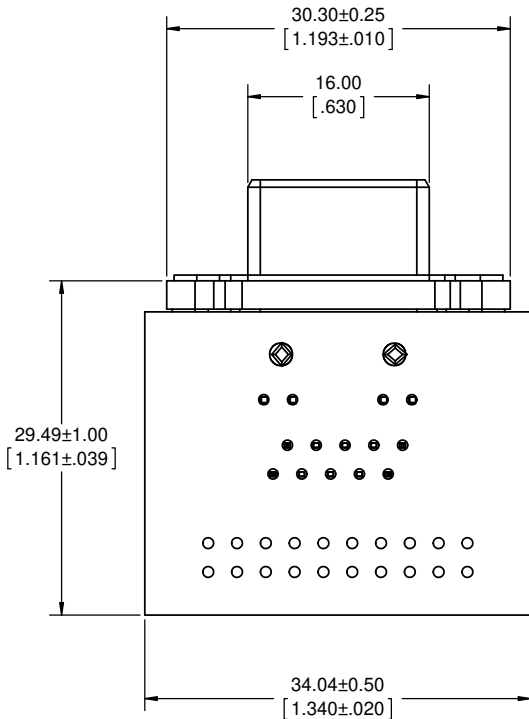
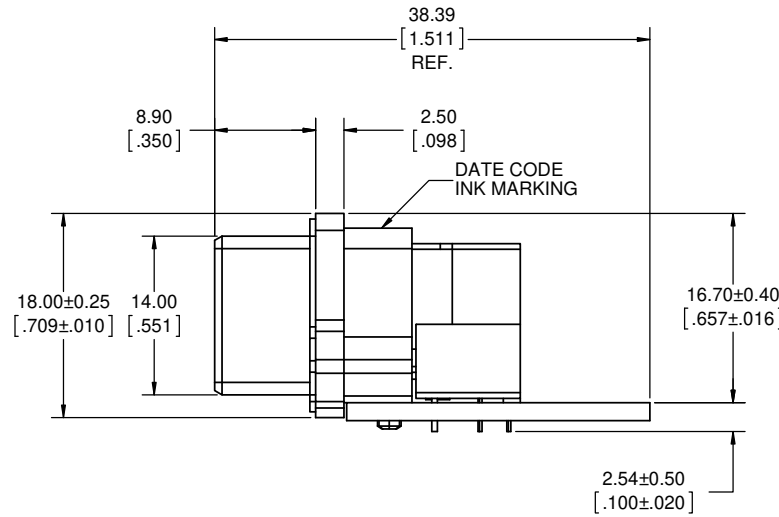
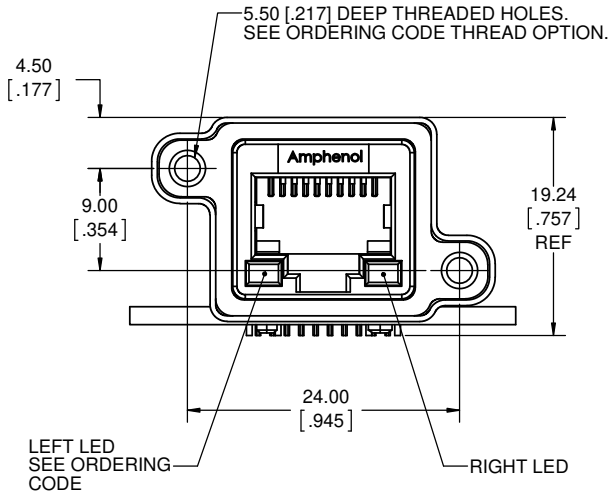

REVISIONS			
REV	DESCRIPTION, ECN, EAR NO.	DATE	APP'D
E	PRODUCT DRAWING (EAR 14166)	APR18/13	K.L.
F	PRODUCT DRAWING (EAR 14166)	AUG05/16	K.L.

ORDERING CODE: MRJ - 5 A X X - X 1

SERIES, RUGGED RJ
 RECEPTACLE, RIGHT ANGLE,
 ON PCB WITH HOLES FOR WIRING

NUMBER OF CONTACTS:
 8 = 8 CONTACTS
 A = 10 CONTACTS

LED OPTION:
 0 = NONE
 1 = LEFT GREEN, RIGHT YELLOW
 4 = LEFT YELLOW, RIGHT GREEN
 5 = LEFT GREEN, RIGHT GREEN

MOUNTING HOLE THREAD OPTION:
 0 = #4-40 UNC THREAD
 M = M3 X 0.5 THREAD

SINGLE PORT

SPECIAL CONNECTORS

MANY UNIQUE FEATURES ARE READILY AVAILABLE TO SUIT CUSTOMER REQUIREMENTS. CONSULT WITH AMPHENOL CANADA FOR DETAILS.

NOTES:

- MATERIAL:**
 ALL MATERIALS ARE RoHS COMPLIANT PER EU DIRECTIVE 2011/65/EU AND AMENDMENTS
 - SHELL - DIECAST ZINC ALLOY, NICKEL PLATED
 - CONTACTS - PHOSPHOR BRONZE WITH 1.27 µm [50 µ"] GOLD OVER 1.27 µm [50 µ"] MINIMUM NICKEL ON THE MATING AREA AND MATTE TIN OVER NICKEL ON THE CONTACT TAILS.
 - INSERTS - ENGINEERING THERMOPLASTIC, FLAMMABILITY RATING UL94V-0
 - REAR INSERTS: BLACK NYLON, FRONT INSERT: CLEAR POLYCARBONATE
 - LED'S - EPOXY LENS, STEEL TAILS WITH TIN PLATING
 - GASKET - SILICONE RUBBER
 - PCB - FR-4 FIBERGLASS, LEAD FREE
- ENVIRONMENTAL PERFORMANCE PER IEC 60529 CODE IP67 FOR SEAL BETWEEN MATING AREA AND PCB SIDE OF CONNECTOR. GASKET PROVIDES SEAL TO INSIDE FACE OF PANEL.
- CURRENT RATING: 1.5 AMPERES.
- CONTACT RESISTANCE: 50 MILLIOHMS MAXIMUM (SUBJECT TO VERIFICATION).
- OPERATING TEMPERATURE: -40°C TO +105°C.
- LED CHARACTERISTICS: FORWARD DC CURRENT 25 mA MAX, FORWARD VOLTAGE 2.5 V MAX @ 2 mA.
- AVAILABLE MATING AREA COVERS PROVIDE ADDED PROTECTION. CONSULT WITH AMPHENOL CANADA FOR DETAILS.
- RECOMMENDED TORQUE FOR PANEL MOUNT SCREWS: 0.45 TO 0.65 Nm [4.0 TO 5.75 IN-LBS] FOR STEEL SCREWS WITH 3.00 [.118] MINIMUM THREAD ENGAGEMENT.
- CUSTOMER TO VERIFY THAT ALL PROCESS CLEANERS ARE COMPATIBLE WITH POLYCARBONATE MATERIAL.



UNLESS SPECIFIED OTHERWISE	DRAWN	L.KIM	MAR08/07
PRIMARY UNITS MILLIMETERS	CHECKED		
SECONDARY INCHES	M.E. APP'D		
REFERENCE IN PARENTHESES	Q.A. APP'D		
GENERAL TOLERANCES	DWG APPR.	A.GREEN	MAR08/07
1 DECIMAL PLACE	ENG. REL. NO.		
2 DECIMAL PLACES ±0.15	REF.		
3 DECIMAL PLACES	THIRD ANGLE PROJECTION		
ANGULAR DEGREES	DO NOT SCALE DRAWING		

Amphenol Canada Corp.
 www.amphenolcanada.com
MRJ SERIES RUGGED MODULAR JACK,
8 OR 10 POSITION, RIGHT ANGLE,
ON PCB WITH HOLES FOR WIRING,
RoHS COMPLIANT

DWG. NO.	REV
P-MRJ-5AXX-X1	F
CODE ID NO. 03554	DWG SIZE: X
SCALE: 3:1	SHEET 1 OF 2

REVISIONS			
REV	DESCRIPTION, ECN, EAR NO.	DATE	APP'D
E	PRODUCT DRAWING (EAR 14166)	APR18/13	K.L.
F	PRODUCT DRAWING (EAR 14166)	AUG05/16	K.L.

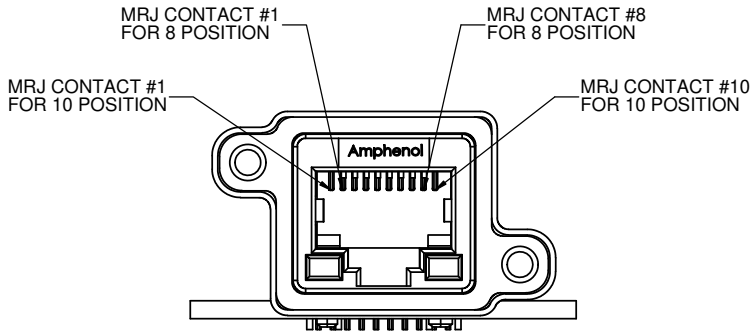

MRJ TO PCB CONNECTIONS		
MRJ 8 POSITION	MRJ 10 POSITION	PCB
SHELL/GROUND	SHELL/GROUND	10
-	1	2
1	2	12
2	3	3
3	4	13
4	5	4
5	6	14
6	7	5
7	8	15
8	9	6
-	10	16
LED 1	LED 1	1
LED 2	LED 2	11
LED 3	LED 3	7
LED 4	LED 4	17

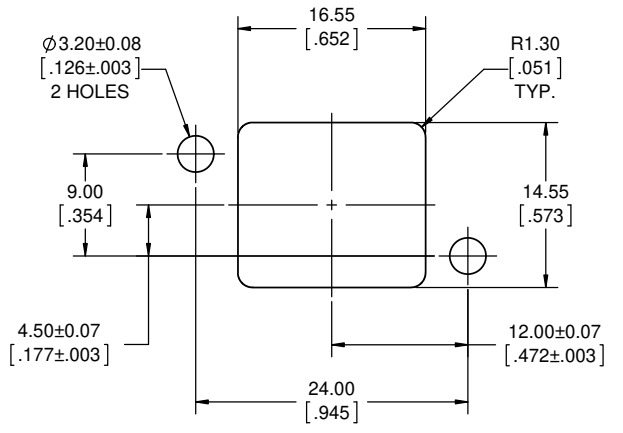

RECOMMENDED PANEL CUTOUT
OUTSIDE PANEL VIEW

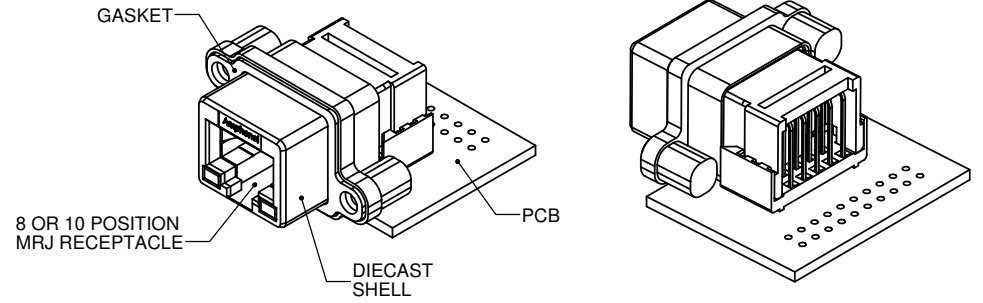
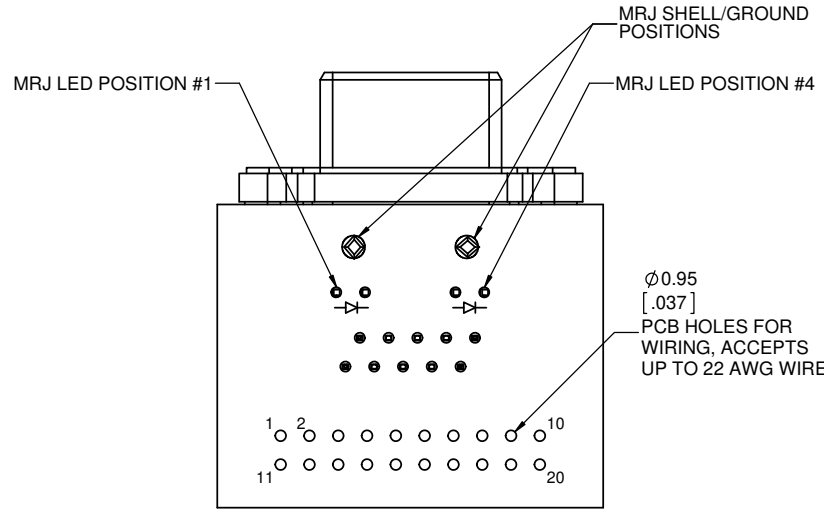

UNLESS SPECIFIED OTHERWISE	DRAWN	L.KIM	MAR08/07
PRIMARY UNITS MILLIMETERS	CHECKED		
SECONDARY INCHES	M.E. APP'D		
REFERENCE IN PARENTHESES	Q.A. APP'D		
GENERAL TOLERANCES	DWG APPR.	A.GREEN	MAR08/07
1 DECIMAL PLACE	ENG. REL. NO.		
2 DECIMAL PLACES ±0.15	REF.		
3 DECIMAL PLACES	THIRD ANGLE PROJECTION		
ANGULAR DEGREES	DO NOT SCALE DRAWING		

Amphenol Canada Corp.
www.amphenolcanada.com

**MRJ SERIES RUGGED MODULAR JACK,
8 OR 10 POSITION, RIGHT ANGLE,
ON PCB WITH HOLES FOR WIRING,
RoHS COMPLIANT**

DWG. NO. **P-MRJ-5AXX-X1** REV **F**

CODE ID NO. 03554 DWG SIZE: X SCALE: 3:1 SHEET 2 OF 2