



Chipsmall Limited consists of a professional team with an average of over 10 year of expertise in the distribution of electronic components. Based in Hongkong, we have already established firm and mutual-benefit business relationships with customers from,Europe,America and south Asia,supplying obsolete and hard-to-find components to meet their specific needs.

With the principle of “Quality Parts,Customers Priority,Honest Operation,and Considerate Service”,our business mainly focus on the distribution of electronic components. Line cards we deal with include Microchip,ALPS,ROHM,Xilinx,Pulse,ON,Everlight and Freescale. Main products comprise IC,Modules,Potentiometer,IC Socket,Relay,Connector.Our parts cover such applications as commercial,industrial, and automotives areas.

We are looking forward to setting up business relationship with you and hope to provide you with the best service and solution. Let us make a better world for our industry!



Contact us

Tel: +86-755-8981 8866 Fax: +86-755-8427 6832

Email & Skype: info@chipsmall.com Web: www.chipsmall.com

Address: A1208, Overseas Decoration Building, #122 Zhenhua RD., Futian, Shenzhen, China



DP-M SERIES

Related Information

- General terms and conditions..... F-7
- Sensor selection guide P.731~
- Glossary of terms P.1469~
- General precautions P.1472



Conforming to
EMC Directive



panasonic.net/id/pidsx/global



Digital



With analog
output

High accuracy & resolution

High accuracy and resolution

Due to differential pressure sensing, the pressure can be set with a high resolution of 0.01 kPa.D {1 mmH₂O.D} over a pressure range of 0 to 2.00 kPa.D {0 to 204 mmH₂O.D} and, moreover, the detection accuracy is within ± 1 % F.S.

Setting resolution

0.01 kPa.D
{1 mmH₂O.D}

Repeatability

Within ± 1 % F.S.

Detecting clogging of filter

The clogging of a filter can be reliably detected by the differential pressure, indicating the time for filter replacement.

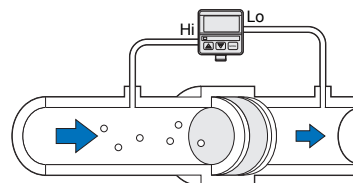

FUNCTIONS

Bright display and easy key operation

Three bright red 7-segment LEDs, 12 mm 0.472 in high, are incorporated in the compact body. They can be clearly read not only in a dark place, but also, in a well-lit place. Further, initialization or pressure settings can be easily done with key operation while looking at the display.

Pressure unit selectable

The pressure unit can be selected from "kPa" and "mmH₂O" according to your requirement. Further, during measurement, the pressure unit can be recognized at a glance from the pressure unit indicator.

kPa



mmH₂O

(When the pressure unit is changed, threshold values and the measured pressure value are automatically converted.)

Versatile control with two output modes

① Hysteresis mode

The lower threshold value and the upper threshold value establish the hysteresis of the comparative output.

② Window comparator mode

The comparative outputs can be made ON or OFF by a pressure within the limits set by the upper and the lower threshold levels.

VARIETIES

Analog current output type: DP-M2A

DP-M2A is incorporated also with the analog current output (4 to 20 mA). Hence, it is ideally suited for real time monitoring and multi-point control in combination with an analog controller (ultra-compact digital panel controller CA2 series).

FIBER
SENSORS

LASER
SENSORS

PHOTOELECTRIC
SENSORS

MICRO
PHOTOELECTRIC
SENSORS

AREA
SENSORS

LIGHT CURTAINS /
SAFETY
COMPONENTS

PRESSURE /
FLOW
SENSORS

INDUCTIVE
PROXIMITY
SENSORS

PARTICULAR
USE SENSORS

SENSOR
OPTIONS

SIMPLE
WIRE-SAVING
UNITS

WIRE-SAVING
SYSTEMS

MEASUREMENT
SENSORS

STATIC ELECTRICITY
PREVENTION
DEVICES

LASER
MARKERS

PLC

HUMAN MACHINE
INTERFACES

ENERGY CONSUMPTION
VISUALIZATION
COMPONENTS

FA COMPONENTS

MACHINE VISION
SYSTEMS

UV CURING
SYSTEMS

Selection
Guide

Pressure/
Digital Display

Pressure/
Head-separated

Flow

DP-100

DP-M

ORDER GUIDE

Type	Appearance	Rated pressure range	Model No.	Pressure port	Output
Standard		0 to 2.00 kPa.D {0 to 204 mmH ₂ O.D}	DP-M2	ø4.6 mm ø0.181 in resin pipe	NPN open-collector transistor
With analog current output			DP-M2A		

OPTIONS

Designation	Model No.	Description
Sensor mounting bracket	MS-PE-1	L-shaped bracket [Two M3 (length 8 mm 0.315 in) screws with washers are attached.]
Panel mounting bracket	MS-PE-2	It can be used for mounting on a panel (1 to 3.2 mm 0.039 to 0.126 in thick).
Front protection cover	MS-PE-3	It protects the sensor's adjustment panel. (It can be fitted when the panel mounting bracket is used.)
Digital panel controller (Note)	CA2-T1	This is a very small controller which allows two independent threshold level settings. <ul style="list-style-type: none"> Supply voltage: 24 V DC ±10 % No. of inputs: 1 No. (sensor input) Input range: 4 to 20 mA Output: NPN open-collector transistor Main functions: Threshold level setting function, zero-adjust function, scale setting function, hysteresis setting function, start / hold function, auto-reference function, power supply ON-delay function, etc.

Note: Refer to p.1143~ for details of the ultra-compact digital panel controller **CA2** series.

Sensor mounting bracket

- **MS-PE-1**

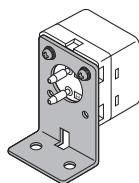

Two M3 (length 8 mm 0.315 in) screws with washers are attached.

Panel mounting bracket Front protection cover

- **MS-PE-2**
- **MS-PE-3**

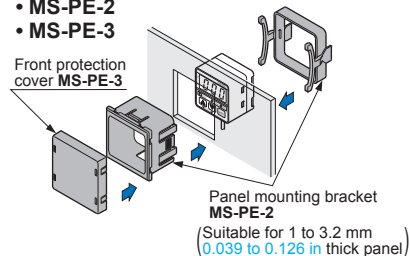

Digital panel controller

- **CA2 series**



FIBER
SENSORS

LASER
SENSORS

PHOTO-
ELECTRIC
SENSORS

MICRO
PHOTO-
ELECTRIC
SENSORS

AREA
SENSORS

LIGHT
CURTAINS/
SAFETY
COMPONENTS

PRESSURE/
FLOW
SENSORS

INDUCTIVE
PROXIMITY
SENSORS

PARTICULAR
USE
SENSORS

SENSOR
OPTIONS

SIMPLE
WIPE-SAVING
UNITS

WIPE-SAVING
SYSTEMS

MEASURE-
MENT
SENSORS

STATIC
ELECTRICITY
PREVENTION
DEVICES

LASER
MARKERS

PLC

HUMAN
MACHINE
INTERFACES

ENERGY
CONSUMPTION
VISUALIZATION
COMPONENTS

FA
COMPONENTS

MACHINE
VISION
SYSTEMS

UV
CURING
SYSTEMS

Selection
Guide

Pressure/
Digital Display

Pressure/
Head-separated

Flow

DP-100

DP-M

SPECIFICATIONS

Type	Standard type	With analog current output type	
Item	Model No.	DP-M2	DP-M2A
Type of pressure	Differential pressure		
Rated pressure range	0 to 2.00 kPa.D {0 to 204 mmH ₂ O.D}		
Set pressure range	0 to 2.00 kPa.D {0 to 204 mmH ₂ O.D}		
Set pressure resolution	0.01 kPa.D {1 mmH ₂ O.D}		
Pressure withstandability	6 kPa.D {612 mmH ₂ O.D}		
Applicable fluid	Non-corrosive gas		
Selectable units	kPa, mmH ₂ O		
Supply voltage	12 to 24 V DC $^{+10}_{-15}$ % Ripple P-P 10 % or less		
Current consumption	50 mA or less	75 mA or less	
Comparative output	NPN open-collector transistor <ul style="list-style-type: none"> • Maximum sink current: 100 mA • Applied voltage: 30 V DC or less (between comparative output and 0 V) • Residual voltage: 1 V or less (at 100 mA sink current) 0.4 V or less (at 16 mA sink current) 		
Utilization category	DC-12 or DC-13		
Output operation	Selectable either normally open (NO) or normally closed (NC) by the key		
Hysteresis	0.01 kPa.D {1 mmH ₂ O.D}		
Repeatability	Within ± 1 % F.S.		
Response time	10 ms or less		
Short-circuit protection	Incorporated		
Analog current output	_____	Output current: 4 to 20 mA (from 0 to 1.96 kPa.D {0 to 200 mmH ₂ O.D}) Zero-point: within 4 mA ± 1 % F.S. Span: within 16 mA ± 3 % F.S. Linearity: within ± 1 % F.S. Load resistance: 0 to 250 Ω	
Display	3 digit red LED display (Sampling rate: 4 times/sec. approx.)		
Displayable pressure range	-0.05 to 2.10 kPa.D {-5 to 210 mmH ₂ O.D}		
Operation	Orange LED (lights up when the comparative output is ON)		
Pressure unit	Red LED (The indicator corresponding to the selected unit lights up during the sensing mode.)		
M1 setting	Red LED (blinks in the M1 setting mode)		
M2 setting	Red LED (blinks in the M2 setting mode)		
Pollution degree	3 (Industrial environment)		
Ambient temperature	0 to +50 °C +32 to +122 °F (No dew condensation), Storage: -10 to +60 °C +14 to +140 °F		
Ambient humidity	35 to 85 % RH, Storage: 35 to 85 % RH		
EMC	EN 61000-6-2, EN 61000-6-4		
Voltage withstandability	1,000 V AC for one min. between all supply terminals connected together and enclosure		
Insulation resistance	50 M Ω , or more, with 500 V DC megger between all supply terminals connected together and enclosure		
Vibration resistance	10 to 150 Hz frequency, 0.75 mm 0.030 in amplitude in X, Y and Z directions for two hours each		
Shock resistance	100 m/s ² acceleration (10 G approx.) in X, Y and Z directions for three times each		
Temperature characteristics	Over ambient temperature range 0 to +50 °C +32 to +122 °F : within ± 3 % F.S. of detected pressure at +25 °C +77 °F		
Pressure port	$\varnothing 4.6$ mm $\varnothing 0.181$ in resin pipe		
Material	Front case: ABS, Rear case: ABS, LED display: Acrylic, Pressure port: PA		
Cable	0.18 mm ² 3-core oil resistant cabtyre cable, 2 m 6.562 ft long	0.18 mm ² 4-core oil resistant cabtyre cable, 2 m 6.562 ft long	
Cable extension	Extension up to total 100 m 328.084 ft (less than 10 m 32.808 ft when conforming to CE marking) is possible with 0.3 mm ² , or more, cable.		
Weight	Net weight: 75 g approx., Gross weight: 135 g approx.		

Note: Where measurement conditions have not been specified precisely, the conditions used were an ambient temperature of +20 °C **+68 °F**.

FIBER SENSORS

LASER SENSORS

PHOTO-ELECTRIC SENSORS

MICRO PHOTO-ELECTRIC SENSORS

AREA SENSORS

LIGHT CURTAINS/SAFETY COMPONENTS

PRESSURE/ FLOW SENSORS

INDUCTIVE PROXIMITY SENSORS

PARTICULAR USE SENSORS

SENSOR OPTIONS

SIMPLE WIRE-SAVING UNITS

WIRE-SAVING SYSTEMS

MEASURE-MENT SENSORS

STATIC ELECTRICITY PREVENTION DEVICES

LASER MARKERS

PLC

HUMAN MACHINE INTERFACES

ENERGY CONSUMPTION VISUALIZATION COMPONENTS

FA COMPONENTS

MACHINE VISION SYSTEMS

UV CURING SYSTEMS

Selection Guide

Pressure/ Digital Display

Pressure/ Head-separated

Flow

DP-100

DP-M

I/O CIRCUIT AND WIRING DIAGRAMS

I/O circuit diagram

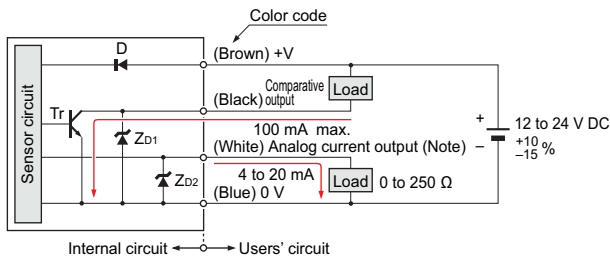

Note: The analog current output is equipped only with the **DP-M2A**.
The analog current output of **DP-M2A** does not incorporate a short-circuit protection circuit. Do not connect it directly to a power supply or a capacitive load.

Symbols ... D: Reverse supply polarity protection diode
ZD1, ZD2: Surge absorption zener diode
Tr: NPN output transistor

Wiring diagram

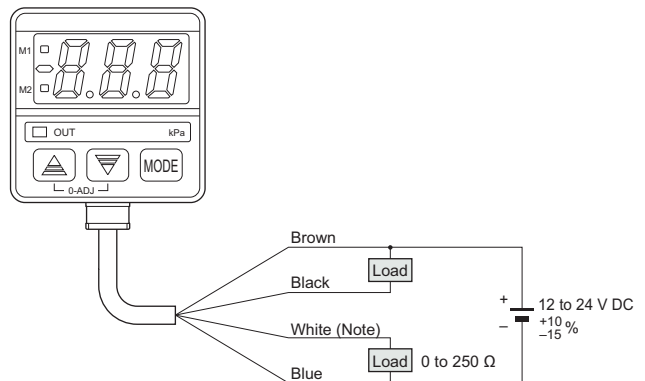

Note: The white lead wire is equipped only with the **DP-M2A**.

PRECAUTIONS FOR PROPER USE

Refer to p.1472 for general precautions.



- Never use this product as a sensing device for personnel protection.
- In case of using sensing devices for personnel protection, use products which meet laws and standards, such as OSHA, ANSI or IEC etc., for personnel protection applicable in each region or country.
- The **DP-M** series is designed for use with non-corrosive gas. It cannot be used for liquid or corrosive gas.

Mounting

- The displayed value may vary by 1 digit (0.01 kPa.D {1 mmH₂O.D}) maximum depending on whether the sensor is installed vertically or horizontally.

- A sensor mounting bracket **MS-PE-1** (optional) may be used. When mounting the sensor with the sensor mounting bracket, the tightening torque should be 0.5 N·m or less.

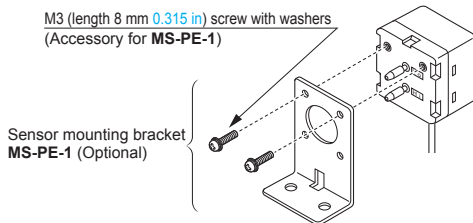

Conditions in use for CE conformity

- The **DP-M** series is a CE conformity product complying with EMC Directive. The harmonized standard with regard to immunity that applies to this product is EN 61000-6-2 and the following condition must be met to conform to that standard.

Conditions

- The sensor should be connected less than 10 m 32.808 ft from the power supply.
- The signal line to connect with this sensor should be less than 30 m 98.425 ft.

Operation

- If setting is impossible even with pressing the MODE key, verify whether the key-protect function is enabled. Please note that pressing down on the MODE key for an extended moment (for 4 sec. or more) will enable the key-protect function as soon as the key is released. The key-protect function is set when the display shows **0n** and is released when the display shows **OFF**.
- If using the window comparator mode, lower threshold value (M1) and upper threshold value (M2) should be set with a difference of 3 digits (0.03 kPa.D {3 mmH₂O.D}) or more. No output will be possible with a 0 to 2 digits difference.

Piping

- Apply higher pressure to the Hi-port and lower pressure to the Lo-port.

- Use flexible tubes (silicone tube etc.) that can fit the pressure ports, $\varnothing 4.6$ mm $\varnothing 0.181$ in in diameter. The tubes should cover more than half the length of the pressure ports.

Recommended tube

- TYGON® tube R-3603, size: internal dia 4 mm 0.157 in, external dia 6 mm 0.236 in, manufactured by Saint-Gobain K. K. Contact the manufacturer for details of the recommended product.

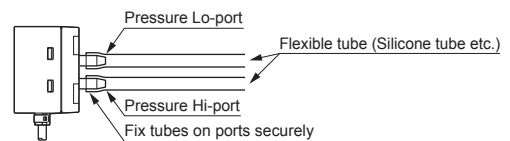

- Notes: 1) TYGON is registered trademarks of Saint-Gobain K. K.
2) Ensure that excessive pressure is not applied to the pressure ports. Since this sensor is designed for detecting small pressures, if excessive pressure or shock is applied to the pressure ports, the diaphragm (pressure sensing device) in the sensor may get damaged.
3) Please do not compress the tube. If the tube is compressed, pressure exceeding the rated value may be generated, damaging the diaphragm (pressure sensing device).

Not good

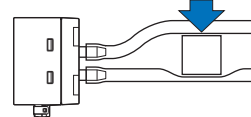

FIBER SENSORS

LASER SENSORS

PHOTO-ELECTRIC SENSORS

MICRO PHOTO-ELECTRIC SENSORS

AREA SENSORS

LIGHT CURTAINS/SAFETY COMPONENTS

PRESSURE/FLOW SENSORS

INDUCTIVE PROXIMITY SENSORS

PARTICULAR USE SENSORS

SENSOR OPTIONS

SIMPLE WIRE-SAVING UNITS

WIRE-SAVING SYSTEMS

MEASUREMENT SENSORS

STATIC ELECTRICITY PREVENTION DEVICES

LASER MARKERS

PLC

HUMAN MACHINE INTERFACES

ENERGY CONSUMPTION VISUALIZATION COMPONENTS

FA COMPONENTS

MACHINE VISION SYSTEMS

UV CURING SYSTEMS

Selection Guide

Pressure/Digital Display

Pressure/Head-separated

Flow

DP-100

DP-M

FIBER SENSORS
LASER SENSORS
PHOTO-ELECTRIC SENSORS
MICRO PHOTO-ELECTRIC SENSORS
AREA SENSORS
LIGHT CURTAINS / SAFETY COMPONENTS
PRESSURE / FLOW SENSORS
INDUCTIVE PROXIMITY SENSORS
PARTICULAR USE SENSORS
SENSOR OPTIONS
SIMPLE WIRE-SAVING UNITS
WIRE-SAVING SYSTEMS
MEASUREMENT SENSORS
STATIC ELECTRICITY PREVENTION DEVICES
LASER MARKERS
PLC
HUMAN MACHINE INTERFACES
ENERGY CONSUMPTION VISUALIZATION COMPONENTS
FA COMPONENTS
MACHINE VISION SYSTEMS
UV CURING SYSTEMS
Selection Guide
Pressure/ Digital Display
Pressure/ Head-separated
Flow
DP-100
DP-M

PRECAUTIONS FOR PROPER USE

Refer to p.1472 for general precautions.

Wiring

- The analog current output of **DP-M2A** does not incorporate a short-circuit protection circuit. Do not connect it directly to a power supply or a capacitive load.

Functional description

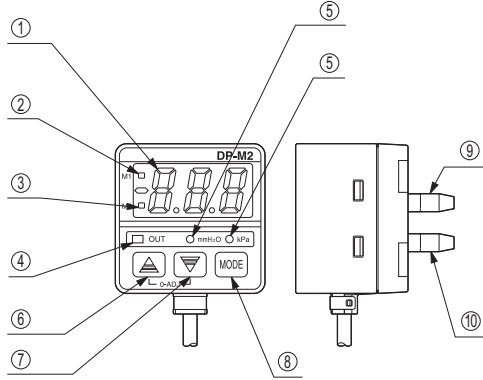

	Description	Function	
①	3 digit LED display (Red)	The measured differential pressure level, setting values, error codes, and key protection sign are displayed.	
②	M1 setting indicator (Red)	Blinks in the lower threshold value (M1) setting mode.	
③	M2 setting indicator (Red)	Blinks in the upper threshold value (M2) setting mode.	
④	Operation indicator (Orange)	Lights up when the comparative output is ON.	
⑤	Pressure unit indicator (mmH ₂ O, kPa) (Red)	<ul style="list-style-type: none"> The indicator of the selected unit lights up during the sensing mode. Both indicators light off during the initial setting mode and during an error occurrence. The indicator of the selected unit blinks during the upper and lower threshold value setting mode. 	
⑥	Increment key (▲)	<ul style="list-style-type: none"> The settable digit is shifted cyclically at every press of the key during the initial setting mode. Pressing the key increases the set value, in the upper and lower threshold value setting mode. 	During the sensing mode, pressing both switches calibrates the sensor into atmospheric zero.
⑦	Decrement key (▼)	<ul style="list-style-type: none"> The set condition changes at every press of the key during the initial setting mode. Pressing the key decreases the set value, in the upper and lower threshold value setting mode. 	
⑧	Mode selection key (MODE)	<ul style="list-style-type: none"> Three modes, the sensing mode, the lower threshold value (M1) setting mode, and the upper threshold value (M2) setting mode, are cyclically selected at every press of the key. During the sensing mode, pressing the key for 4 sec., or more, can make the key protection either effective or ineffective. Holding the increment key (▲) and simultaneously pressing the mode selection key brings the sensor from the sensing mode to the initial setting mode. 	
⑨	Pressure Lo-port	Lower pressure should be applied.	
⑩	Pressure Hi-port	Higher pressure should be applied.	

Output mode and output operation

Hysteresis mode (H) (M1 < M2)

- The lower threshold value and the upper threshold value establish the hysteresis of the comparative output.

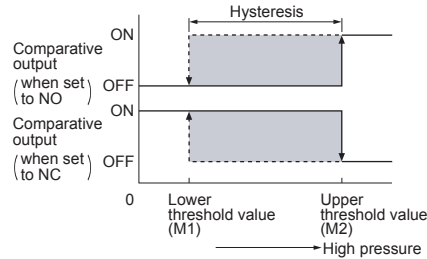

Window comparator mode (L) (M1 < M2)

- The comparative outputs can be made ON or OFF by a pressure within the limits set by the upper and the lower threshold levels.

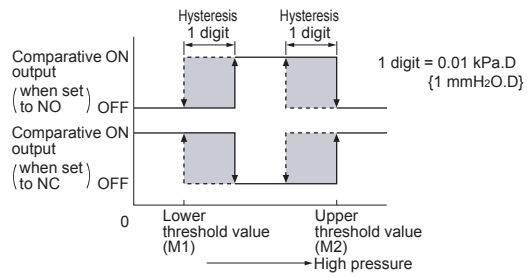

• When operating in window comparator mode (L) lower threshold value (M1) and upper threshold value (M2) should be set with a difference of 3 digits (0.03 kPa.D {3 mmH₂O.D}) or more.

Others

- Use within the rated pressure range.
- Do not apply pressure exceeding the pressure withstandability value. The diaphragm will get damaged and correct operation shall not be maintained.
- Do not use during the initial transient time (0.5 sec.) after the power supply is switched on.
- Do not insert wires, etc., into the pressure port. The diaphragm will get damaged and correct operation shall not be maintained.
- Do not operate the keys with pointed or sharp objects.

DIMENSIONS (Unit: mm in)

The CAD data in the dimensions can be downloaded from our website.

DP-M□ Sensor

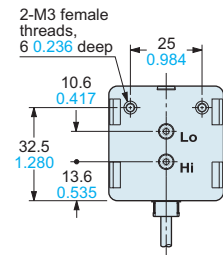
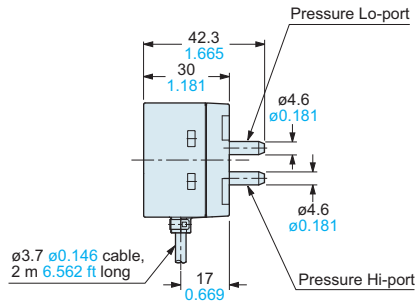
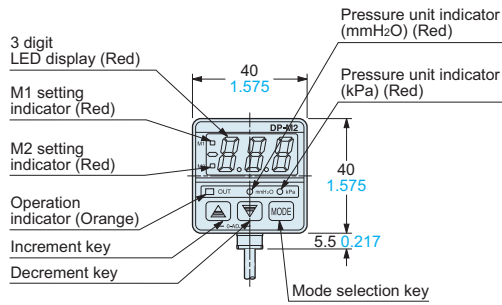

MS-PE-1 Sensor mounting bracket (Optional)

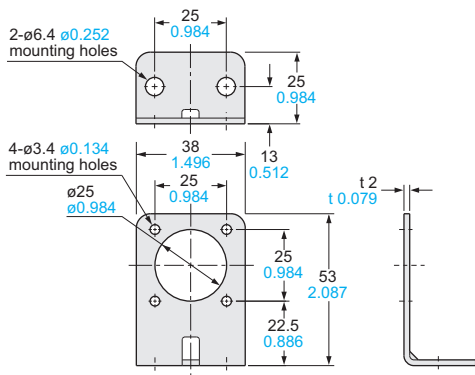

Assembly dimensions

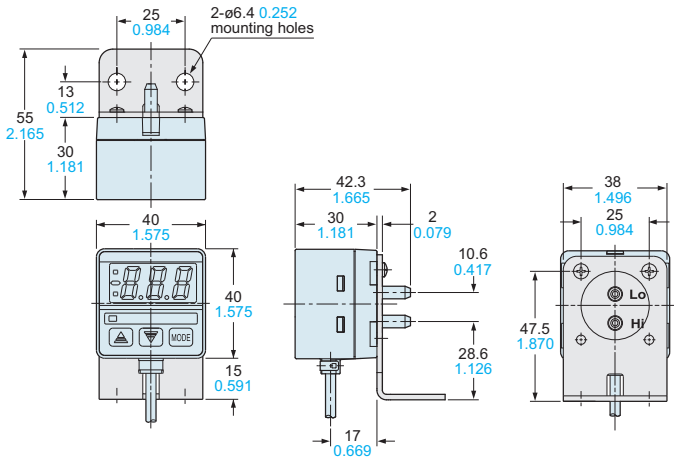

Material: Cold rolled carbon steel (SPCC)
Two M3 (length 8 mm 0.315 in) screws with washers are attached.

MS-PE-2 MS-PE-3 Panel mounting bracket, front protection cover (Optional)

Assembly dimensions

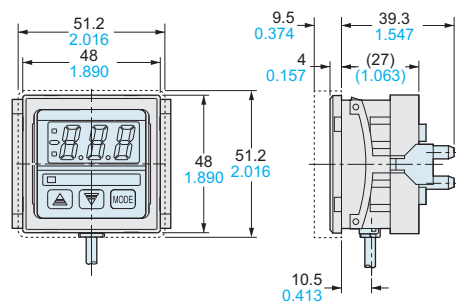

□ portion shows the front protection cover.
Material: Polycarbonate (Front protection cover)
Nylon 6, Polyacetal (Panel mounting bracket)

Panel cut-out dimensions

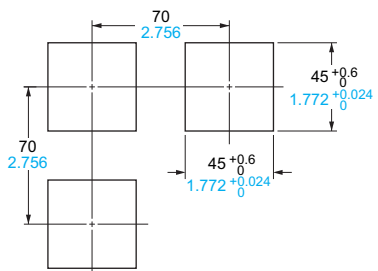

Note: The panel thickness should be 1 to 3.2 mm 0.039 to 0.126 in.

- FIBER SENSORS
- LASER SENSORS
- PHOTO-ELECTRIC SENSORS
- MICRO PHOTO-ELECTRIC SENSORS
- AREA SENSORS
- LIGHT CURTAINS / SAFETY COMPONENTS
- PRESSURE / FLOW SENSORS**
- INDUCTIVE PROXIMITY SENSORS
- PARTICULAR USE SENSORS
- SENSOR OPTIONS
- SIMPLE WIRE-SAVING UNITS
- WIRE-SAVING SYSTEMS
- MEASUREMENT SENSORS
- STATIC ELECTRICITY PREVENTION DEVICES
- LASER MARKERS
- PLC
- HUMAN MACHINE INTERFACES
- ENERGY CONSUMPTION VISUALIZATION COMPONENTS
- FA COMPONENTS
- MACHINE VISION SYSTEMS
- UV CURING SYSTEMS

- Selection Guide
- Pressure/ Digital Display
- Pressure/ Head-separated
- Flow

DP-100

DP-M