



Chipsmall Limited consists of a professional team with an average of over 10 year of expertise in the distribution of electronic components. Based in Hongkong, we have already established firm and mutual-benefit business relationships with customers from,Europe,America and south Asia,supplying obsolete and hard-to-find components to meet their specific needs.

With the principle of “Quality Parts,Customers Priority,Honest Operation,and Considerate Service”,our business mainly focus on the distribution of electronic components. Line cards we deal with include Microchip,ALPS,ROHM,Xilinx,Pulse,ON,Everlight and Freescale. Main products comprise IC,Modules,Potentiometer,IC Socket,Relay,Connector.Our parts cover such applications as commercial,industrial, and automotives areas.

We are looking forward to setting up business relationship with you and hope to provide you with the best service and solution. Let us make a better world for our industry!



Contact us

Tel: +86-755-8981 8866 Fax: +86-755-8427 6832

Email & Skype: info@chipsmall.com Web: www.chipsmall.com

Address: A1208, Overseas Decoration Building, #122 Zhenhua RD., Futian, Shenzhen, China



35508-462		REVISIONS		
ZONE	LTR	DISCRIPTION	DATE	APPROVED
	A12	REDRAWN SAME SIZE; REVISED & STANDARDIZED (SEE CHANGE NOTICE) ECN: 55525-43	11-30-72 LAMBRECHT	<i>[Signature]</i>
	B	(MFG); ADD 9-3895 (PROCESS SPEC); REV STAMPING NOTES ECN 57216-1	12-22-75 <i>[Signature]</i>	<i>[Signature]</i>
	C	(MFG); REV STAMPING NOTE 13 ECN 57738-4	5-19-76 BOWKER	<i>[Signature]</i>
	D	(CL II) WAS 10-101937-12 (PACKING -10SL) ECN: 71290-1	7-15-80 LONGWELL	<i>[Signature]</i>
	E	(CL II) SEE CHANGE NOTICE ECN: 74790-S	12-14-83 Prescott	<i>[Signature]</i>
	F	(CL II) SEE ECN 87190	<i>[Signature]</i>	<i>[Signature]</i>
	G	(CL I) SEE CHANGE NOTICE ECN: A3023	1-23-09	H.BROOKER

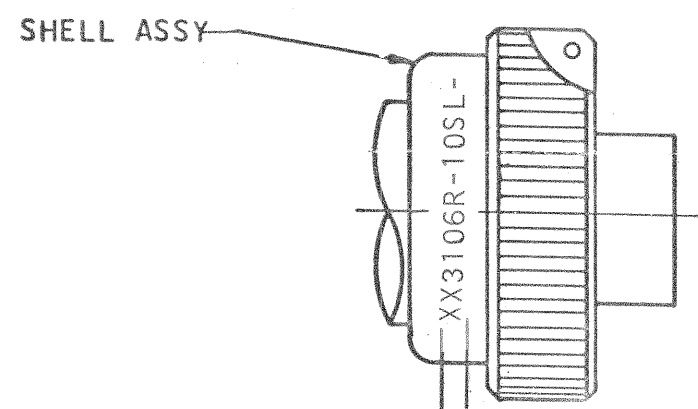

STAMP "AMPHENOL", DATE CODE (9-3895) & MS NO. PER 9-2811
 EXAMPLE: AMPHENOL-7539 JMS3106R-10SL-3S
 OR
 STAMP "AMPHENOL" & SM NO. PER 9-2811
 EXAMPLE: AMPHENOL SM3106R-10SL-3S
 NUT MUST TURN FREELY AFTER STAMPING

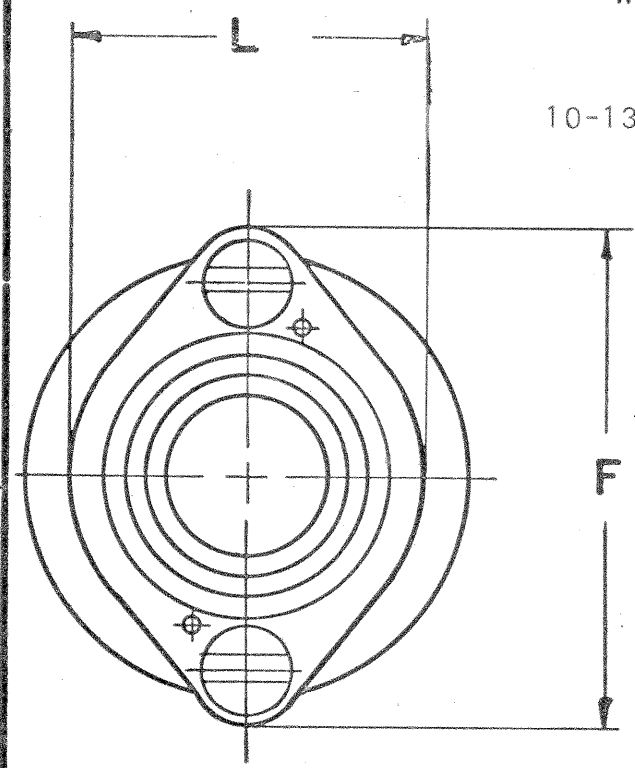

SEE SOLDER WELL DATA
 GROMMET 10-1319XX SERIES

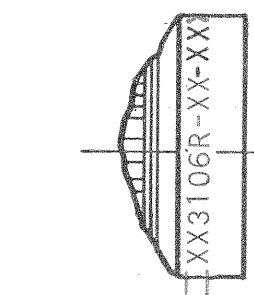
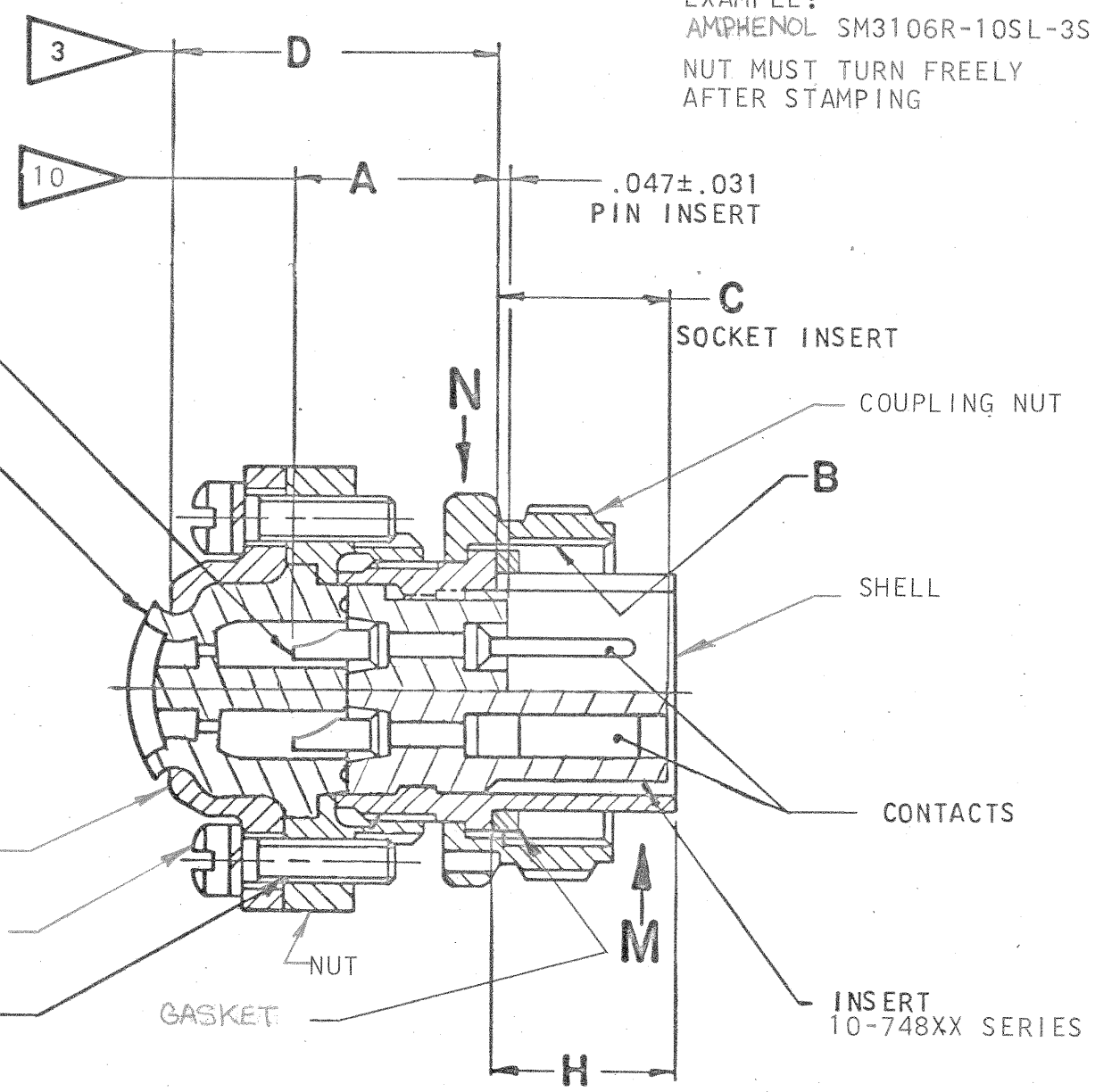

STAMP MS NO., "AMPHENOL" & DATE CODE (9-3895) OPPOSITE KEYWAY PER 9-2811
 EXAMPLE: JMS3106R-8S-1S AMPHENOL-7539
 OR
 STAMP SM NO. OPPOSITE KEYWAY PER 9-2811
 EXAMPLE: SM3106R-8S-1S

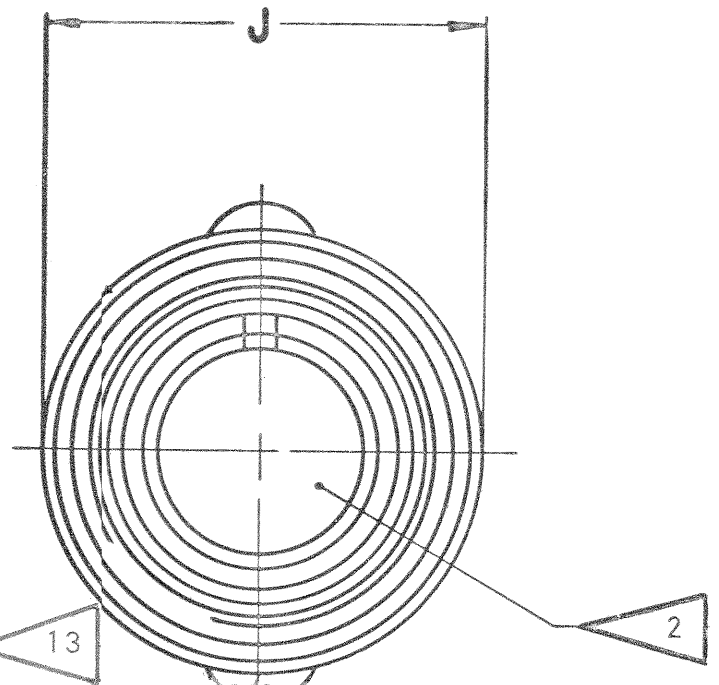

CONTACT DATA (WHERE APPLICABLE)			
THERMOCOUPLE		COAXIAL	
MATERIAL	IDENTIFICATION	ARR	CABLE
CHROMEL	WHITE		
ALUMEL	GREEN		
IRON	BLACK		
CONSTANTAN	YELLOW		

INSERT ARRANGEMENTS CONTAINING THERMOCOUPLE OR COAXIAL CONTACTS MUST HAVE SUCH CONTACTS ASSEMBLED INTO THE INSERT IN PROPER LOCATIONS AS SPECIFIED BY APPLICABLE DRAWING L-11908-() THRU L-11948-().

STANDARD SOLDER WELL DATA											SPECIAL SOLDER WELL DATA			THERMOCOUPLE	
CONTACT SIZE	0	4	8	12	16	8 FOR NO. 6 WIRE	12 FOR NO. 10 WIRE	16 FOR NO. 12 WIRE	12	16					
WELL DIA	.469 ⁺ .005 -.003	.332 ⁺ .005 -.003	.209 ⁺ .004 -.002	.116 ⁺ .004 -.002	.078 ⁺ .004 -.002	.250±.003	.152 ⁺ .004 -.002	.109 ⁺ .004 -.001	.125 ⁺ .004 -.002	.094 ⁺ .004 -.002					
WELL DEPTH	.625	.625	.500	.375	.250	.500	.250	.188	.250	.188					

FIND NO.	QTY REQD	CODE IDENT	PART NUMBER	DESCRIPTION	NOTE REF
UNLESS OTHERWISE SPECIFIED LINEAR DIMENSIONS ARE IN INCHES. TOLERANCES: .XXX ± .010, .XX ± .03, .X ± .1, ANGLES ± 2°. OTHER STANDARDS PER 9-3800 AND MIL-D-1000. NOTE REF					
MATERIAL SPEC			PROCESS SPEC TEST	SIGNATURES	DATES
9-3106-5			9-3103-1	PREPARED E. PESSAGNO	1-7-66
9-2437			9-2811	CHECKED <i>[Signature]</i>	10-2-73
9-3895			9-3895	APPROVED <i>[Signature]</i>	12-7-72
				APPROVED <i>[Signature]</i>	10-4-73

PARTS LIST

The Bendix Corporation
 Electrical Components Division
 Sidney, New York

TITLE: CONNECTOR, ELECTRICAL PLUG, TYPE MS-R, SM-R (MC)

SIZE: C
 CODE IDENT NO: 77820
 10-190608 THRU 10-190650

SCALE: NONE
 SEE PARTS LIST
 REF: 10-131608/50
 SHEET: 1 OF 2

SEE SHEET 2 NOTES;

USE OF THIS DOCUMENT IS UNLIMITED. DOCUMENTS REFERENCED HEREON CONTAIN LIMITED RIGHTS DATA.

NEXT ASSEMBLY

10-190608/50

4

3

2

1

ASSEMBLY NUMBER	13 14 MS OR SM NO.		SHELL SIZE	SHELL	COUPLING NUT	SLEEVE	NUT	SCREW (2 REQ'D)	PACKING	A MAX	B THREAD CLASS 2B	C +.047 -.000	D MAX	F MAX	G THREAD CLASS 2	H ±.005	J DIA MAX	L DIA MAX
10-190608-	3106R-8S-		-8S	10-37266-8	10-37265-8	10-130029-83	10-130028-83	10-101152--83	10-101937-08	.607	.500 -28UNEF	.531	1.057	.959	6-32UNC	.531	.741	.557
10-190610-	-10S-		-10S	10-37266-10	10-37265-10		-103	10-101152-83	10-101937-10		.625 -24UNEF			1.026			.875	.682
10-190611-	-10SL-		-10SL	10-113488-11	(SHELL ASSY)		-123		10-101937-10		.625 -24UNEF			1.120			.946	.807
10-190612-	-12S-		-12S	10-37266-12	10-37265-12		-123		10-101937-12		.750 -20UNEF			1.120			.995	.807
10-190613-	-12-		-12		-13		-123		10-101937-12	.857	.750 -20UNEF	.719	1.212	1.120		.719	.995	.807
10-190614-	-14S-		-14S	-14	-14		-143		10-101937-14	.607	.875 -20UNEF	.531	1.057	1.307		.531	1.123	.932
10-190615-	-14-		-14	-15	-15		-143		10-101937-14	.857	.875 -20UNEF	.719	1.212	1.307		.719	1.123	.932
10-190616-	-16S-		-16S	-16	-16		-163		10-101937-16	.607	1.000 -20UNEF	.531	1.057	1.432		.531	1.250	1.057
10-190617-	-16-		-16	-17	-17		-163		10-101937-16	.857	1.000 -20UNEF	.719	1.212	1.432		.719	1.250	1.057
10-190618-	-18-		-18	-18	-18		-183		10-101937-18		1.125 -18UNEF			1.557			1.333	1.182
10-190620-	-20-		-20	-20	-20		-203	10-101151-83	10-101937-20		1.250 -18UNEF			1.744	8-32UNC		1.461	1.291
10-190622-	-22-		-22	-22	-22		-223	10-101151-83	10-101937-22		1.375 -18UNEF			1.869	8-32UNC		1.588	1.432
10-190624-	-24-		-24	-24	-24		-243	10-101151-93	10-101937-24		1.500 -18UNEF		1.291	1.994			1.715	1.557
10-190628-	-28-		-28	-28	-28		-283	10-101151-93	10-101937-28		1.750 -18UNS			2.166			1.968	1.807
10-190632-	-32-		-32	-32	-32		-323	10-101270-93	10-101937-32		2.000 -18UNS		1.353	2.541	10-32UNF		2.209	2.057
10-190636-	-36-		-36	-36	-36		-363		10-101937-36		2.250 -16UN			2.729			2.463	2.260
10-190640-	-40-		-40	-40	-40		-403		10-101937-40		2.500 -16UN			2.979			2.719	2.510
10-190641/50-				NOT AVAILABLE														



8. ALL LOCKWIRE HOLES ARE .045 DIA MIN.
7. LUBRICATE PACKING WITH A THIN COATING OF COMPOUND MIL-S-8660.
6. SEE DRAWING 10-190208 THRU 10-190250 & OTHERS FOR MATING RECEPTACLE ASSEMBLIES.
5. TO COMPLETE ASSY NO., MS NO., OR SM NO., ADD APPLICABLE INSERT ARRANGEMENT SUFFIX TO BASE NUMBERS LISTED ABOVE (FOR ALTERNATE ARRANGEMENTS, REFER TO 9-2437).
4. SEE WORK ORDER FOR PERMISSIBLE ADDITIONAL OR ALTERNATE STAMPING.
3. DIMENSION INDICATES FINAL INSTALLATION. FOR STORAGE & SHIPPING, NUT & SLEEVE MUST BE LOOSELY COUPLED.
2. FOR CONTACT SIZE, SPACING & SERVICE RATING SEE DRAWINGS MS33680 THRU MS33693 & L-11908/48.
1. FOR COMPONENT PART NUMBERS, QUANTITIES AND RELEASE STATUS OF THE DESIRED UNIT, SEE SEPARATE PARTS LIST.
14. CONNECTOR ASSEMBLIES 10-190608-50/ 10-190650-50/-99, EXCEPT THOSE LISTED IN NOTE 13, ARE STAMPED WITH SM NO.
13. CONNECTOR ASSEMBLIES 10-190608-1/-49 THRU 10-190650-1/-49 AND 10-190636-52, 10-190640-56 AND 10-190640-62 ARE STAMPED WITH MS NO.
12. ALL UNUSED GROMMET HOLES MUST BE FILLED WITH APPROPRIATE SIZE SEALING PLUGS; SEALING PLUGS ARE PART OF MS STAMPED ASSEMBLIES ONLY.
11. PACKAGE PER PRODUCTION PROCESS SHEET.
10. INCREASE "A" DIMENSION BY .312 FOR SIZE "0" CONTACT ONLY.
9. UNITS ILLUSTRATED MEET THE MATERIAL & FINISH REQUIREMENTS OF MIL-C-5015.

NOTES:

SIZE C	CODE IDENT NO. 77820	10-190608 THRU 10-190650
SCALE	REF	SHEET 2

10-190608/50]