



Chipsmall Limited consists of a professional team with an average of over 10 year of expertise in the distribution of electronic components. Based in Hongkong, we have already established firm and mutual-benefit business relationships with customers from,Europe,America and south Asia,supplying obsolete and hard-to-find components to meet their specific needs.

With the principle of “Quality Parts,Customers Priority,Honest Operation,and Considerate Service”,our business mainly focus on the distribution of electronic components. Line cards we deal with include Microchip,ALPS,ROHM,Xilinx,Pulse,ON,Everlight and Freescale. Main products comprise IC,Modules,Potentiometer,IC Socket,Relay,Connector.Our parts cover such applications as commercial,industrial, and automotives areas.

We are looking forward to setting up business relationship with you and hope to provide you with the best service and solution. Let us make a better world for our industry!



## Contact us

Tel: +86-755-8981 8866 Fax: +86-755-8427 6832

Email & Skype: info@chipsmall.com Web: www.chipsmall.com

Address: A1208, Overseas Decoration Building, #122 Zhenhua RD., Futian, Shenzhen, China





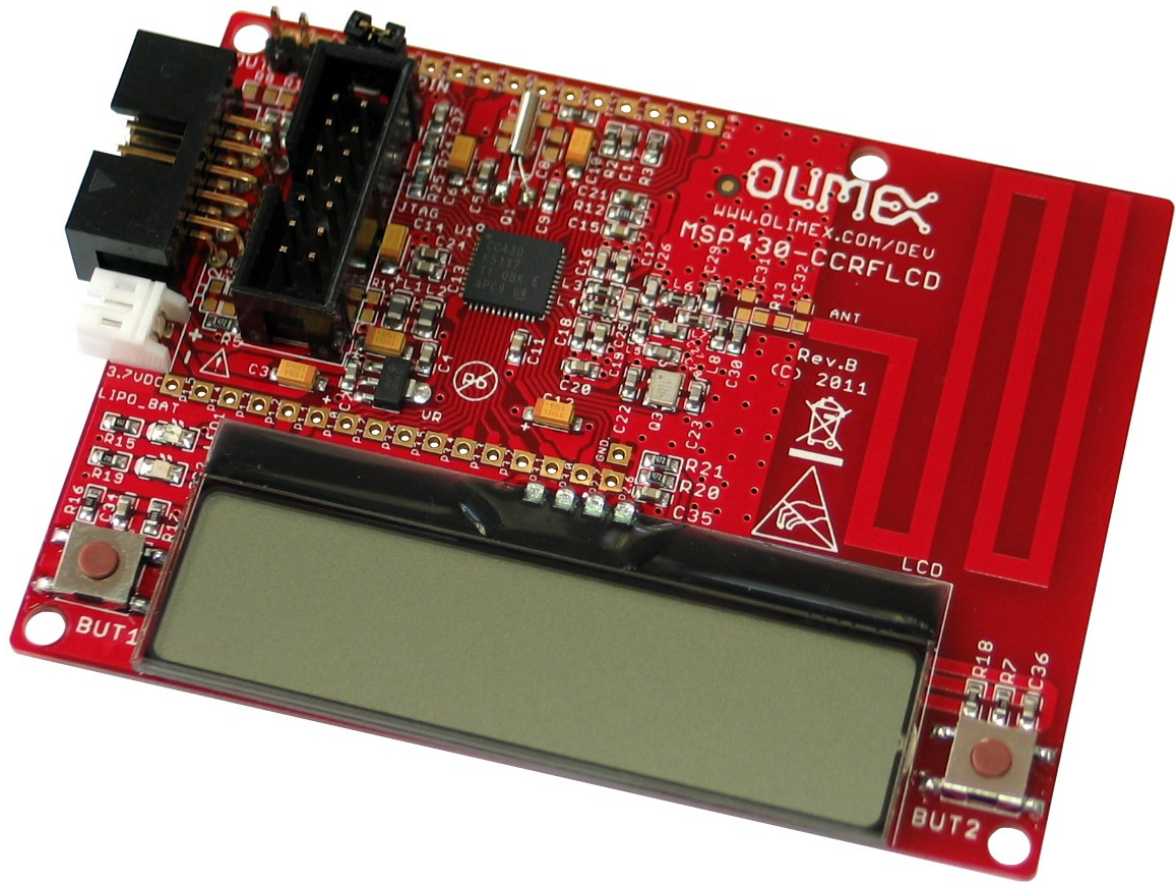

## MSP430-CCRFLCD development board Users Manual



All boards produced by Olimex are ROHS compliant

Revision A, November 2011  
Copyright(c) 2011, OLIMEX Ltd, All rights reserved

## INTRODUCTION:

**MSP430-CCRFLCD** is development board with CC430F5137IRGZ microcontroller from Texas Instruments. This ultra-low-power microcontroller has integrated CC1101 RF transceiver. The board has also LCD, two status leds, two user buttons and UEXT, which can be modified as device or host. MSP430-CCRFLCD can communicate with other boards with integrated CC1101 RF transceiver via radio connection.

## BOARD FEATURES:

- Microcontroller: **CC430F5137IRGZ**
- JTAG
- UEXT
- LCD 1x9
- LIPO\_BAT connector for Lithium-ion polymer battery which permits outdoor communication between two or more MSP430-CCRFLCD boards
- on-board voltage regulator
- On-board pcb antenna
- Supported radio frequencies bands 868/915 MHz – software selectable. By default – 868 MHz.
- Maximal permissible distance between two MSP430-CCRFLCD boards depends on RF chip's output power, data transfer rate and the selected radio frequency band. For more information, see the table below.  
*Results given there are taken via using 2 MSP430-CCRF boards, but because of the slight difference between MSP430-CCRF and MSP430-CCRFLCD we are expecting results closer to this!*
- two user buttons
- two status leds
- RTC crystal
- extension pin holes for most of the microcontroller pins
- FR-4, 1.00 mm, soldermask, component print
- Dimensions: 84.84 x 63.50mm (3.34 x 2.50")

<i>RF Frequency</i>	<i>Output Power</i>	<i>Data Rate</i>	<i>Measured Distance</i>
868MHz	10dBm	1.2kBaud	155m
868MHz	10dBm	38.4kBaud	110m
868MHz	10dBm	250kBaud	85m
915MHz	10dBm	1.2kBaud	140m
915MHz	10dBm	38.4kBaud	100m
915MHz	10dBm	250kBaud	60m

*This measurements were taken via using “RF Connection\_toggle LED” demo software loaded at two alike MSP430-CCRF boards!*

## **ELECTROSTATIC WARNING:**

The **MSP430-CCRFLCD** board is shipped in protective anti-static packaging. The board must not be subject to high electrostatic potentials. General practice for working with static sensitive devices should be applied when working with this board.

## **BOARD USE REQUIREMENTS:**

**Cables:** The cable you will need depends on the programmer/debugger you use. If you use MSP-JTAG-TINY, MSP-JTAG-TINY-V2, or MSP-JTAG-ISO, you will need USB A-B cable. If you use MSP-JTAG, you will need LPT cable.

**Hardware:** Programmer/Debugger [MSP-JTAG-TINY](#), MSP-JTAG-TINY-V2, [MSP-JTAG-ISO](#), [MSP-JTAG](#), [MSP-JTAG-RE](#), or other compatible programming/debugging tool.

You can also use other Olimex's board MSP-CCRFLCD, or MSP-CCRF for radio communication.

## **PROCESSOR FEATURES:**

**MSP430-CCRFLCD** board use microcontroller **CC430F5137IRGZFB100** with these features:

- True System-on-Chip (SoC) for Low-Power Wireless Communication Applications
- Wide Supply Voltage Range: 1.8 V to 3.6 V
- Ultra-Low Power Consumption:
  - CPU Active Mode (AM): 160  $\mu$ A/MHz
  - Standby Mode (LPM3 RTC Mode): 2.0  $\mu$ A
  - Off Mode (LPM4 RAM Retention): 1.0  $\mu$ A
  - Radio in RX: 15 mA, 250 kbps, 915 MHz
- MSP430™ System and Peripherals
  - 16-Bit RISC Architecture, Extended Memory, up to 20-MHz System Clock
  - Wake-Up From Standby Mode in Less Than 6  $\mu$ s
  - Flexible Power Management System with SVS and Brownout
  - Unified Clock System with FLL
  - 16-Bit Timer TA0, Timer\_A with Five Capture/Compare Registers
  - 16-Bit Timer TA1, Timer\_A with Three Capture/Compare Registers
  - Hardware Real-Time Clock
  - Two Universal Serial Communication Interfaces
    - USCI\_A0 supporting UART, IrDA, SPI
    - USCI\_B0 supporting I<sup>2</sup>C, SPI
  - 12-Bit A/D Converter With Internal Reference, Sample-and-Hold, and Autoscan Features

- Comparator
- 128-bit AES Security Encryption/Decryption Coprocessor
- 32-Bit Hardware Multiplier
- Three-Channel Internal DMA
- Serial Onboard Programming, No External Programming Voltage Needed
- Embedded Emulation Module (EEM)
- High-Performance Sub-1-GHz RF Transceiver Core
  - Wide Supply Voltage Range: 2.0 V to 3.6 V
  - Frequency Bands: 300 MHz to 348 MHz, 389 MHz to 464 MHz, and 779 MHz to 928 MHz.
  - Programmable Data Rate From 0.6 kBaud to 500 kBaud
  - High Sensitivity (-117 dBm at 0.6 kBaud, -111 dBm at 1.2 kBaud, 315 MHz, 1% Packet Error Rate)
  - Excellent Receiver Selectivity and Blocking Performance
  - Programmable Output Power Up to +12 dBm for All Supported Frequencies
  - 2-FSK, 2-GFSK, and MSK Supported as well as OOK and Flexible ASK Shaping
  - Flexible Support for Packet-Oriented Systems: On-Chip Support for Sync Word Detection, Address Check, Flexible Packet Length, and Automatic CRC Handling
  - Support for Automatic Clear Channel Assessment (CCA) Before Transmitting (for Listen-Before-Talk Systems)
  - Digital RSSI Output
  - Suited for Systems Targeting Compliance With EN 300 220 (Europe) and FCC CFR Part 15 (US)
  - Suited for Systems Targeting Compliance With Wireless M-Bus Standard EN 13757-4:2005
  - Support for Asynchronous and Synchronous Serial Receive/Transmit Mode for Backward Compatibility With Existing Radio Communication Protocols

Program (KB)	SRAM (KB)	Timer_A <sup>(1)</sup>	USCI		ADC12_A	Comp_B	I/O
			Channel A: UART/LIN /IrDA/SPI	Channel B: SPI/ I <sup>2</sup> C			
32	4	5, 3	1	1	6 ext/ 4 int ch.	6 ch.	30

(1) 5, 3 - represents two instantiations of Timer\_A, the first instantiation having 5 and the second instantiation having 3 capture compare registers and PWM output generators, respectively.



## MEMORY ORGANIZATION:

		<b>CC430F5137<sup>(1)</sup></b>
Main Memory (flash)	Total Size	32kB
Main: Interrupt vector		00FFFFh to 00FF80h
Main: code memory	Bank 0	32kB 00FFFFh to 008000h
RAM	Total Size	4kB
	Sect 1	2kB 002BFFh to 002400h
	Sect 0	2kB 0023FFh to 001C00h
Device Descriptor		128 B 001AFFh to 001A80h
		128 B 001A7Fh to 001A00h
Information memory (flash)	Info A	128 B 0019FFh to 001980h
	Info B	128 B 00197Fh to 001900h
	Info C	128 B 0018FFh to 001880h
	Info D	128 B 00187Fh to 001800h
Bootstrap loader (BSL) memory (flash)	BSL 3	512 B 0017FFh to 001600h
	BSL 2	512 B 0015FFh to 001400h
	BSL 1	512 B 0013FFh to 001200h
	BSL 0	512 B 0011FFh to 001000h
Peripherals		4 KB 000FFFh to 0h

(1) All memory regions not specified here are vacant memory, and any access to them causes a Vacant Memory Interrupt.

# SCHEMATIC:

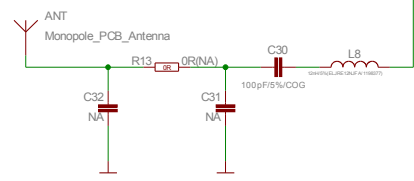
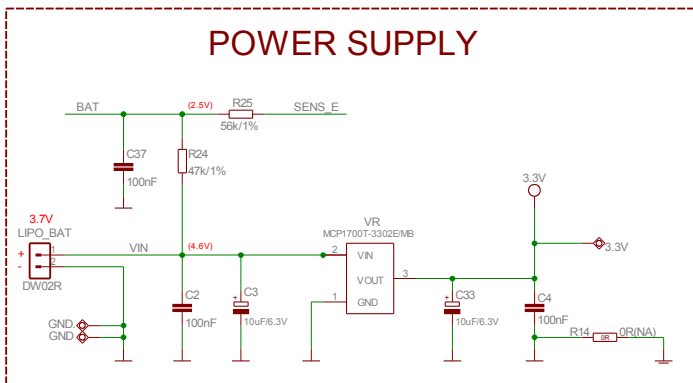
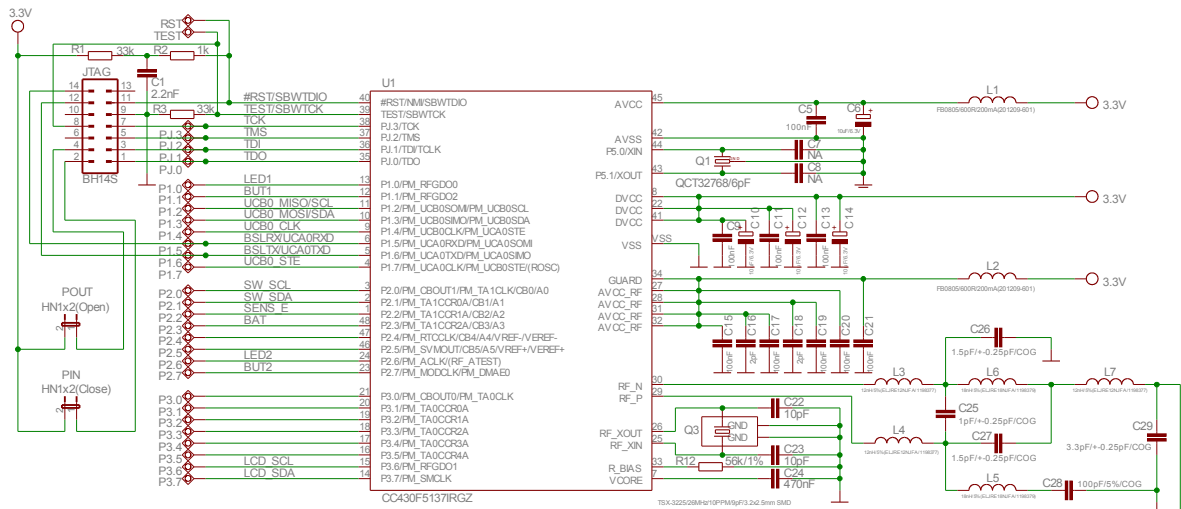
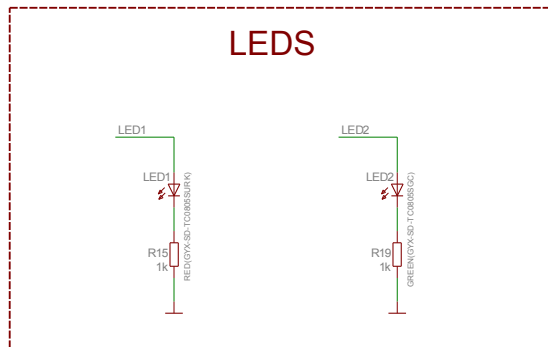
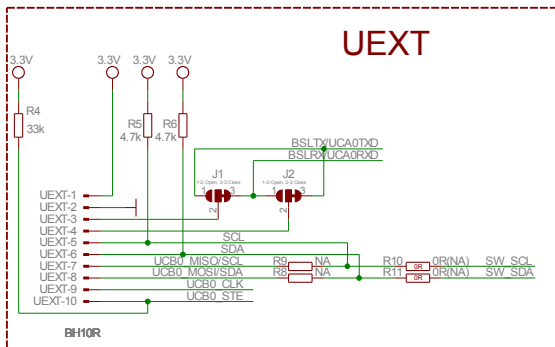
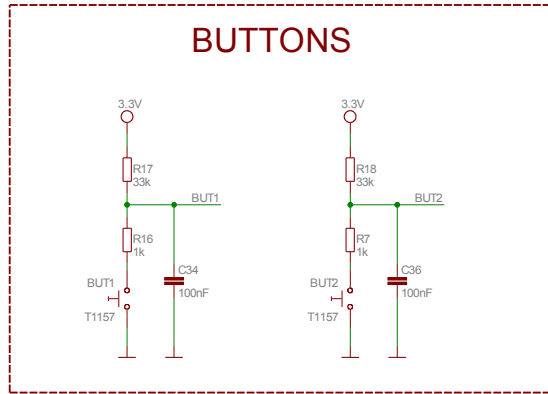
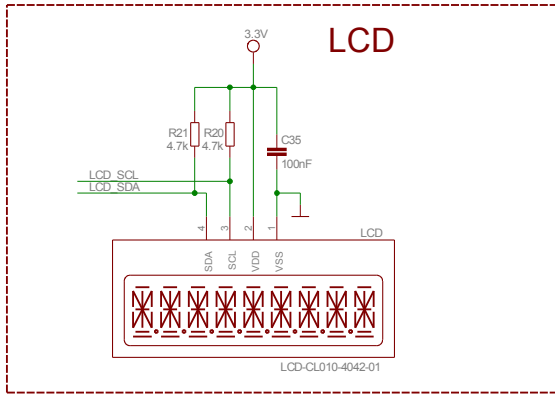

**MSP430-CCRFLCD**

Rev.B

COPYRIGHT(C) 2011, OLIMEX LTD.

<http://www.olimex.com/dev>



## BOARD LAYOUT:

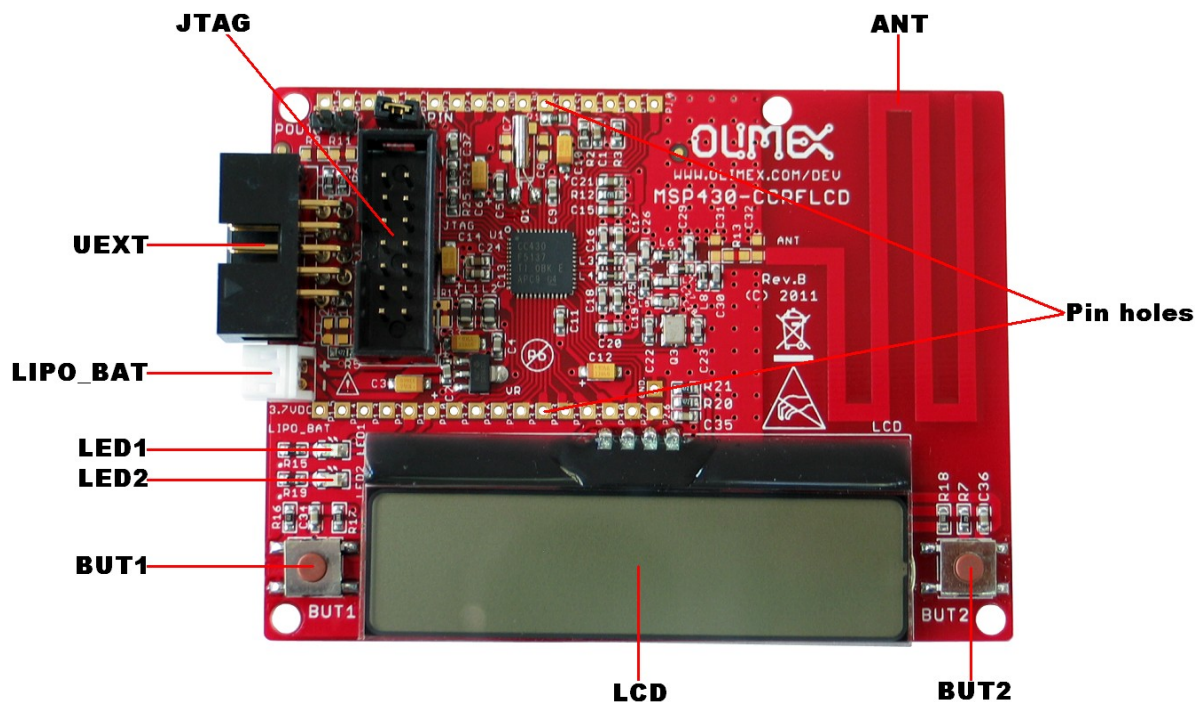

## POWER SUPPLY CIRCUIT:

MSP430-CCRFLCD can take power from:

-External power supply via LIPO\_BAT connector 3.7 VDC from Lithium-ion polymer battery

-JTAG

The programmed board power consumption is about 20 mA with all peripherals enabled.

## RESET CIRCUIT:

MSP430-CCRFLCD reset circuit includes R1 (33k), R2 (1k $\Omega$ ), C1 (2.2nF), JTAG pin 11 and CC430F5137IRGZ pin 40 (#RST/NMI/SBWTIDIO).

## CLOCK CIRCUIT:

Quartz crystal Q1 32.768 kHz is connected to CC430F5137IRGZ pin 44 (P5.0/XIN) and pin 43 (P5.1/XOUT).

Quartz crystal Q3 26 MHz is connected to CC430F5137IRGZ pin 25 (RF\_XIN) and pin 26 (RF\_XOUT).

## JUMPER DESCRIPTION:

### **Power In jumper:**

**P\_IN** jumper connects power supply from JTAG connector. You have to ensure that your circuit doesn't draw more than few milliamperes current or the power supply may decrease due to the JTAG port current limitations. **P\_IN** is useful and must be used mostly to program the microcontroller.

### **Power Out jumper:**

**P\_OUT** jumper connects power from MSP430-CCRFLCD to JTAG connector. When this jumper cap is placed, the power supply of JTAG connector will follow the power supply of the board. This is useful when your board works at lower than +3,3V power supply.

### **Note:**

**P\_IN** and **P\_OUT** jumper caps should not be placed at the same time.

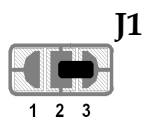

This jumper, when is in position 1-2 - UEXT pin 3 (signal TX) is connected to CC430F5137IRGZ pin 5 (signal BSLTX/UCA0TXD); when the jumper is in position 2-3 - UEXT pin 3 (signal TX) is connected to CC430F5137IRGZ pin 6 (signal BSLRX/UCA0RXD)

Default state is shorted in position 2-3.

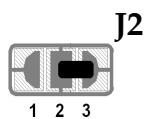

This jumper, when is in position 1-2 - UEXT pin 4 (signal RX) is connected to CC430F5137IRGZ pin 6 (signal BSLRX/UCA0RXD); when the jumper is in position 2-3 - UEXT pin 4 (signal RX) is connected to CC430F5137IRGZ pin 5 (signal BSLTX/UCA0TXD)

Default state is shorted in position 2-3.

When jumpers J1 and J2 are shorted in position 1-2 - the board is configured as host and can be used as host for some of our module boards. When these jumpers are shorted in position 2-3 - the board is configured as device and can be used as module board.

## INPUT/OUTPUT:

**Status Led** with name **LED1 (red)** connected to CC430F5137IRGZ pin 13 (P1.0/PM\_RFGDO0).

**Status Led** with name **LED2 (green)** connected to CC430F5137IRGZ pin 24 (P2.6/PM\_ACLK).

**User button** with name **BUT1** connected to CC430F5137IRGZ pin 12 (P1.1/PM\_RFGDO2).

**User button** with name **BUT2** connected to CC430F5137IRGZ pin 23 (P2.7/PM\_MODCLK).

**LCD 1x9** - 9 segments LCD without font generator

**EXTERNAL CONNECTORS DESCRIPTION:**

**JTAG:**

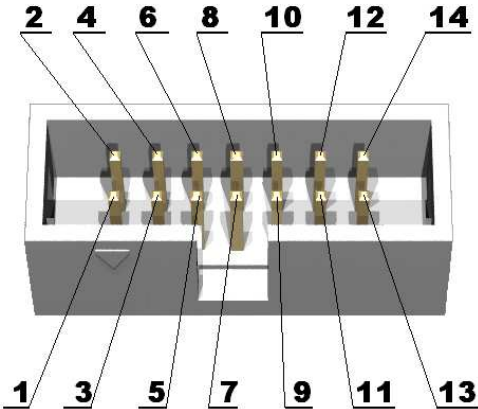

Pin #	Signal Name	Pin #	Signal Name
1	TDO	2	JTAG power supply
3	TDI	4	VCC
5	TMS	6	Not Connected
7	TCK	8	TEST/SBWTCK
9	GND	10	Not Connected
11	#RST/SBWDIO	12	BSLTX/UCA0TXD
13	Not Connected	14	BSLRX/UCA0RXD

**LIPO BAT:**

Pin #	Signal Name
1	VIN
2	GND

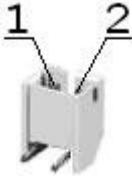

**UEXT:**

Pin #	Signal Name
1	VCC
2	GND
3	TX
4	RX
5	SCL
6	SDA
7	UCB0_MISO/SC L
8	UCB0_MOSI/SD A
9	UCB0_CLK
10	UCB0_STE

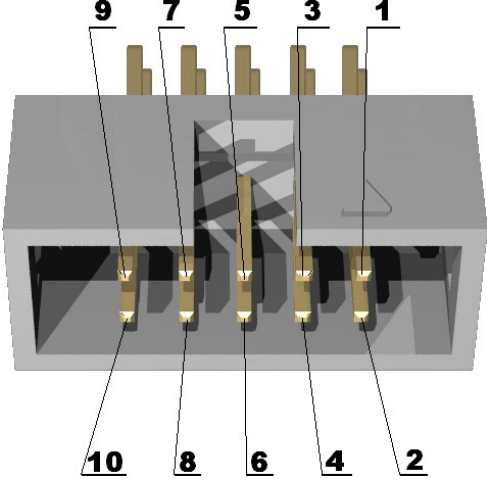



**Pin holes:**

Pin #	Signal Name	Pin #	Signal Name
PJ.0	TDO	P2.6	LED2
PJ.1	TDI	P2.7	BUT2
PJ.2	TMS	P3.0	P3.0
PJ.3	TCK	P3.1	P3.1
TEST	TEST/SBWTCK	P3.2	P3.2
RST	#RST/SBWT DIO	P3.3	P3.3
3.3V	VCC	P3.4	P3.4
GND	GND	P3.5	P3.5
P2.5	P2.5	P3.6	LCD_SCL
P2.4	P2.4	P3.7	LCD_SDA
P2.3	BAT	P1.0	LED1
P2.2	SENS_E	P1.1	BUT1
P2.1	SW_SDA	P1.2	UCB0_MISO/SCL
P2.0	SW_SCL	P1.3	UCB0_MOSI/SDA
P1.7	UCB0_STE	P1.4	UCB0_CLK
P1.6	BSLTX/UCA0TX D	P1.5	BSLRX/UCA0RXD

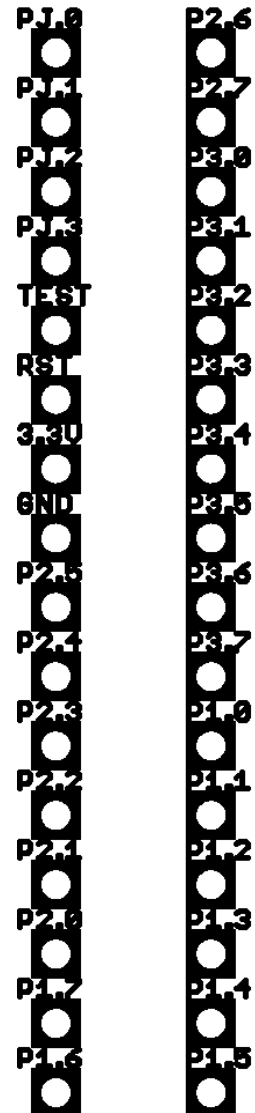

# MECHANICAL DIMENSIONS:

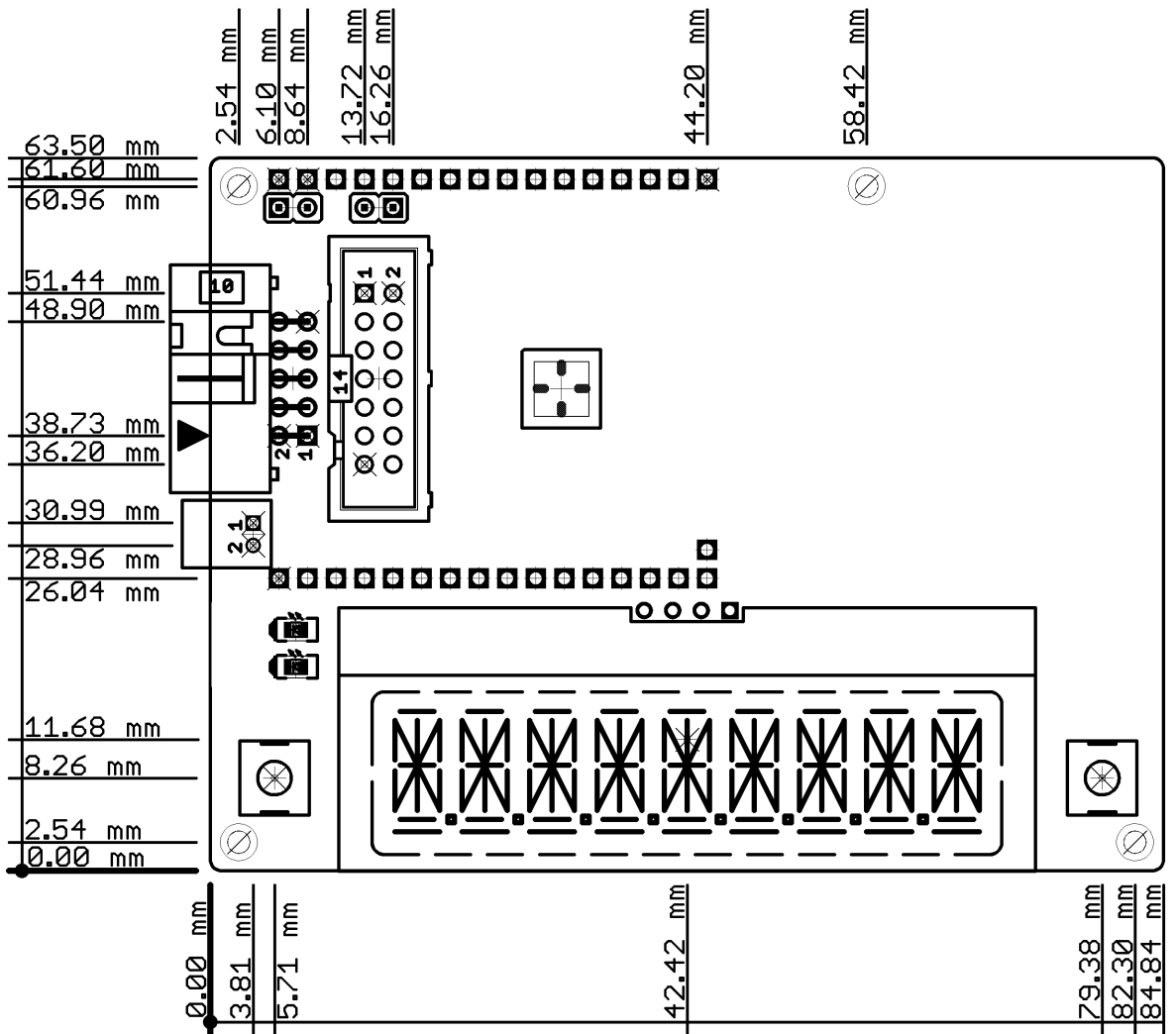

## AVAILABLE DEMO SOFTWARE:

- Blinking Leds sourced by DCO - leads "MSP430-CCRFLCD's" on-board "LED1" and "LED2" to blink with frequency ~ 1Hz. When "LED1" is on "LED2" is off and vice-versa. Clock source -> DCO.
- Blinking Leds sourced by RTC - leads "MSP430-CCRFLCD's" on-board "LED1" and "LED2" to blink with frequency ~ 1Hz. When "LED1" is on "LED2" is off and vice-versa. Clock source -> crystal 32.768kHz.
- Blinking Leds sourced by RTC and USART Echo - MSP430-CCRFLCD's on-board "LED1" and "LED2" are blinking again with frequency ~ 1Hz. by RTC and USART Echo" If USART has received a character, then it returns echo.
- Toggle LEDx when BUTx is pressed - When BUT1 is pressed then LED1 is switched over. When BUT2 is pressed then LED2 is switched over.
- Buttons and LCD - Visualize at LCD which one button you have pressed
- RF Connection\_ press BUT - This example realize simple RF connection between 2 MSP430-CCRFLCD boards. Pressing BUT1 at the first board will toggle LED1 at the second board and vice-versa!
- RF Connection\_toggle LED - This example again realize simple RF connection between 2 MSP430-CCRFLCD boards. Both boards are sending ~4 packets per second with length 10 bytes. Whenever any board has received a valid packet, it switches-over its LED1! Packet sending can be enabled/disabled individually for everyone board by pressing its button BUT1.

## ORDER CODE:

MSP430-CCRFLCD - assembled and tested board

### How to order?

You can order to us directly or by any of our distributors.  
Check our web [www.olimex.com/dev](http://www.olimex.com/dev) for more info.

## Revision history:

Board's revision: Rev. B, May 2011

Manual's revision: Rev. Initial, September 2011

Rev. A, November 2011

- **BOARD FEATURES** - added is table which describes maximal permissible distance between two MSP430-CCRF boards versus different RF settings. MSP430-CCRFLCD is slightly different from MSP430-CCRF so we are expecting closer results.

- **SCHEMATIC** - is updated to last version - with changed C22 and C23 values from 15pF to 10pF.

- **AVAILABLE DEMO SOFTWARE** - "RF Connection" is changed to "RF Connection\_press BUT". "RF Connection\_toggle LED" was added.



**Disclaimer:**

© 2011 Olimex Ltd. All rights reserved. Olimex®, logo and combinations thereof, are registered trademarks of Olimex Ltd. Other terms and product names may be trademarks of others.

The information in this document is provided in connection with Olimex products. No license, express or implied or otherwise, to any intellectual property right is granted by this document or in connection with the sale of Olimex products.

Neither the whole nor any part of the information contained in or the product described in this document may be adapted or reproduced in any material from except with the prior written permission of the copyright holder.

The product described in this document is subject to continuous development and improvements. All particulars of the product and its use contained in this document are given by OLIMEX in good faith. However all warranties implied or expressed including but not limited to implied warranties of merchantability or fitness for purpose are excluded.

This document is intended only to assist the reader in the use of the product. OLIMEX Ltd. shall not be liable for any loss or damage arising from the use of any information in this document or any error or omission in such information or any incorrect use of the product.