



Chipsmall Limited consists of a professional team with an average of over 10 year of expertise in the distribution of electronic components. Based in Hongkong, we have already established firm and mutual-benefit business relationships with customers from,Europe,America and south Asia,supplying obsolete and hard-to-find components to meet their specific needs.

With the principle of “Quality Parts,Customers Priority,Honest Operation,and Considerate Service”,our business mainly focus on the distribution of electronic components. Line cards we deal with include Microchip,ALPS,ROHM,Xilinx,Pulse,ON,Everlight and Freescale. Main products comprise IC,Modules,Potentiometer,IC Socket,Relay,Connector.Our parts cover such applications as commercial,industrial, and automotives areas.

We are looking forward to setting up business relationship with you and hope to provide you with the best service and solution. Let us make a better world for our industry!



Contact us

Tel: +86-755-8981 8866 Fax: +86-755-8427 6832

Email & Skype: info@chipsmall.com Web: www.chipsmall.com

Address: A1208, Overseas Decoration Building, #122 Zhenhua RD., Futian, Shenzhen, China



THIS COPY IS PROVIDED ON A RESTRICTED BASIS AND IS NOT TO BE USED IN ANY WAY DETRIMENTAL TO THE INTERESTS OF PANDUIT CORP.

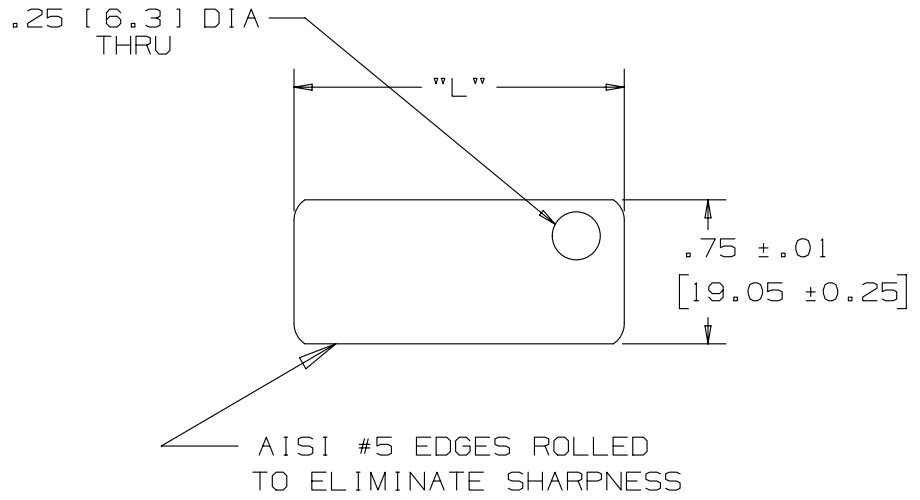

PANDUIT PART NUMBER	MATERIAL	PACKAGE QUANTITY	LENGTH = "L" ± .02
MT172-C	304 SS	100	1.72 [43]
MT172-C316	316 SS	100	1.72 [43]
MT350-C	304 SS	100	3.50 [89]
MT350-C316	316 SS	100	3.50 [89]

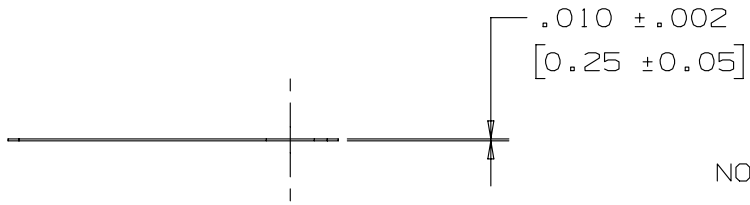

NOTES:

- BRACKETS [] DENOTES DIMENSIONS IN MILLIMETERS
- CUSTOM PERMANENT MARKING AVAILABLE CONSULT FACTORY
- TOLERANCES:
 .XXX = ±.010 [.25]
 .XX = ±.02 [.5]
 .X = ±.03 [.8]
 ANGLES = ±2°

REV	DATE	BY	CHK	APR	DESCRIPTION	ECN
03A	3/13	JAMB	MIM	RGRO	UPDATE DRAWING TO NEW PANDUIT GLOBAL TITLE BLOCK WITH PANDUIT LOGO	SSECN01031
02	5/02	JAMB	JAC	JAC	MATERIAL FOR PART NUMBER MT172-C & MT350-C WAS 302 SS	09145
01	1/01	KMD	JAC	JAC	MT172-C316 WAS MT172-316C, MT350-C316 WAS MT-316C. CAD FILE SPEC WAS NPC-S41084_00	09062
00	11/91	SM	JAC	LA	RELEASED	00679

TITLE		METAL TAGS - 1 HOLE	
		CUSTOMER DRAWING	
ITEM REVISION NAME		N41064BS/03	
DATASET FILE NAME		N41064BS_DC/03A	
UNLESS OTHERWISE SPECIFIED, DIMENSIONAL TOLERANCES ARE: IN [mm]		PANDUIT	
.x ± .1 [2.54] .xxx ± .005 [.127] .xx ± .01 [.25] ANGLES ± 5 °			
		THIRD ANGLE PROJECTION	
DRAWN BY	DATE	CHK	SCALE
SAM	11/11/91	JAC	1:1
DRAWING NUMBER:		N41064BS_DC	
SHT 1 OF 1			SIZE
			A