



Chipsmall Limited consists of a professional team with an average of over 10 year of expertise in the distribution of electronic components. Based in Hongkong, we have already established firm and mutual-benefit business relationships with customers from,Europe,America and south Asia,supplying obsolete and hard-to-find components to meet their specific needs.

With the principle of “Quality Parts,Customers Priority,Honest Operation,and Considerate Service”,our business mainly focus on the distribution of electronic components. Line cards we deal with include Microchip,ALPS,ROHM,Xilinx,Pulse,ON,Everlight and Freescale. Main products comprise IC,Modules,Potentiometer,IC Socket,Relay,Connector.Our parts cover such applications as commercial,industrial, and automotives areas.

We are looking forward to setting up business relationship with you and hope to provide you with the best service and solution. Let us make a better world for our industry!



Contact us

Tel: +86-755-8981 8866 Fax: +86-755-8427 6832

Email & Skype: info@chipsmall.com Web: www.chipsmall.com

Address: A1208, Overseas Decoration Building, #122 Zhenhua RD., Futian, Shenzhen, China



1.35V DDR3L SDRAM SODIMM

MT18KSF2G72HZ – 16GB

Features

- DDR3L functionality and operations supported as defined in the component data sheet
- 204-pin, small outline dual in-line memory module (SODIMM) with ECC
- Fast data transfer rates: PC3-14900, PC3-12800
- 16GB (2 Gig x 72)
- $V_{DD} = 1.35V$ (1.283–1.45V)
- $V_{DD} = 1.5V$ (1.425–1.575V)
- Backward compatible to $V_{DD} = 1.5V \pm 0.075V$
- $V_{DDSPD} = 3.0\text{--}3.6V$
- Supports ECC error detection and correction
- Nominal and dynamic on-die termination (ODT) for data, strobe, and mask signals
- Dual-rank
- On-board I²C temperature sensor with integrated serial presence-detect (SPD) EEPROM
- Fixed burst chop (BC) of 4 and burst length (BL) of 8 via the mode register set (MRS)
- Selectable BC4 or BL8 on-the-fly (OTF)
- Gold edge contacts
- Halogen-free
- Fly-by topology
- Terminated control, command, and address bus

Figure 1: 204-Pin SODIMM (MO-268 R/C D1)

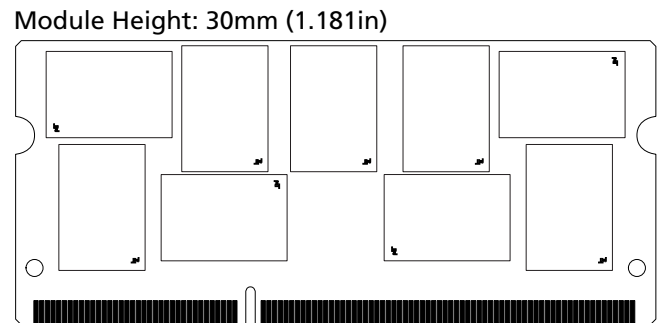

Options

- Operating temperature
 - Commercial ($0^{\circ}C \leq T_A \leq 70^{\circ}C$)
- Package
 - 204-pin DIMM (halogen-free)
- Frequency/CAS latency
 - 1.07ns @ CL = 13 (DDR3-1866)
 - 1.25ns @ CL = 11 (DDR3-1600)

Marking

- None
- Z
- 1G9
- 1G6

Table 1: Key Timing Parameters

Speed Grade	Industry Nomenclature	Data Rate (MT/s)								t _{RCD} (ns)	t _{RP} (ns)	t _{RC} (ns)
		CL = 13	CL = 11	CL = 10	CL = 9	CL = 8	CL = 7	CL = 6	CL = 5			
-1G9	PC3-14900	1866	1600	1333	1333	1066	1066	800	667	13.125	13.125	47.125
-1G6	PC3-12800	–	1600	1333	1333	1066	1066	800	667	13.125	13.125	48.125
-1G4	PC3-10600	–	–	1333	1333	1066	1066	800	667	13.125	13.125	49.125
-1G1	PC3-8500	–	–	–	–	1066	1066	800	667	13.125	13.125	50.625
-1G0	PC3-8500	–	–	–	–	1066	–	800	667	15	15	52.5
-80B	PC3-6400	–	–	–	–	–	–	800	667	15	15	52.5

Table 2: Addressing

Parameter	16GB
Refresh count	8K
Row address	64K A[15:0]
Device bank address	8 BA[2:0]
Device configuration	8Gb (1 Gig x 8)
Column address	2K A[11, 9:0]
Module rank address	2 S#[1:0]

Table 3: Part Numbers and Timing Parameters – 8GB Modules

Base device: MT41K1G8,¹ 8Gb 1.35V DDR3L SDRAM

Part Number ²	Module Density	Configuration	Module Bandwidth	Memory Clock/ Data Rate	Clock Cycles (CL- ^t RCD- ^t RP)
MT18KSF2G72HZ-1G9__	16GB	2 Gig x 72	14.9 GB/s	1.07ns/1866MT/s	13-13-13
MT18KSF2G72HZ-1G6__	16GB	2 Gig x 72	12.8 GB/s	1.25ns/1600 MT/s	11-11-11

- Notes:
1. The data sheet for the base device can be found on Micron's web site.
 2. All part numbers end with a two-place code (not shown) that designates component and PCB revisions. Consult factory for current revision codes. Example: MT18KSF2G72HZ-1G9A2.



Pin Assignments

Table 4: Pin Assignments

204-Pin DDR3 SODIMM Front								204-Pin DDR3 SODIMM Back							
Pin	Symbol	Pin	Symbol	Pin	Symbol	Pin	Symbol	Pin	Symbol	Pin	Symbol	Pin	Symbol	Pin	Symbol
1	V _{REFDQ}	53	V _{SS}	105	A1	157	DM5	2	V _{SS}	54	DQ28	106	A2	158	V _{SS}
3	V _{SS}	55	DQ24	107	A0	159	DQ42	4	DQ4	56	DQ29	108	BA1	160	DQ46
5	DQ0	57	DQ25	109	V _{DD}	161	DQ43	6	DQ5	58	V _{SS}	110	V _{DD}	162	DQ47
7	DQ1	59	DM3	111	CK0	163	V _{SS}	8	V _{SS}	60	DQS3#	112	CK1	164	V _{SS}
9	V _{SS}	61	V _{SS}	113	CK0#	165	DQ48	10	DQ50#	62	DQS3	114	CK1#	166	DQ52
11	DM0	63	DQ26	115	V _{DD}	167	DQ49	12	DQ50	64	V _{SS}	116	V _{DD}	168	DQ53
13	DQ2	65	DQ27	117	A10/AP	169	V _{SS}	14	V _{SS}	66	DQ30	118	NC	170	V _{SS}
15	DQ3	67	V _{SS}	119	BA0	171	DQS6#	16	DQ6	68	DQ31	120	NC	172	DM6
17	V _{SS}	69	CB0	121	WE#	173	DQS6	18	DQ7	70	V _{SS}	122	RAS#	174	DQ54
19	DQ8	71	CB1	123	V _{DD}	175	V _{SS}	20	V _{SS}	72	CB4	124	V _{DD}	176	DQ55
21	DQ9	73	V _{SS}	125	CAS#	177	DQ50	22	DQ12	74	CB5	126	ODT0	178	V _{SS}
23	V _{SS}	75	DQS8#	127	S0#	179	DQ51	24	DQ13	76	DM8	128	ODT1	180	DQ60
25	DQS1#	77	DQS8	129	S1#	181	V _{SS}	26	V _{SS}	78	V _{SS}	130	A13	182	DQ61
27	DQS1	79	V _{SS}	131	V _{DD}	183	DQ56	28	DM1	80	CB6	132	V _{DD}	184	V _{SS}
29	V _{SS}	81	CB2	133	DQ32	185	DQ57	30	RESET#	82	CB7	134	DQ36	186	DQS7#
31	DQ10	83	CB3	135	DQ33	187	V _{SS}	32	V _{SS}	84	V _{REFCA}	136	DQ37	188	DQS7
33	DQ11	85	V _{DD}	137	V _{SS}	189	DM7	34	DQ14	86	V _{DD}	138	V _{SS}	190	V _{SS}
35	V _{SS}	87	CKE0	139	DQS4#	191	DQ58	36	DQ15	88	A15	140	DM4	192	DQ62
37	DQ16	89	CKE1	141	DQS4	193	DQ59	38	V _{SS}	90	A14	142	DQ38	194	DQ63
39	DQ17	91	BA2	143	V _{SS}	195	V _{SS}	40	DQ20	92	A9	144	DQ39	196	V _{SS}
41	V _{SS}	93	V _{DD}	145	DQ34	197	SA0	42	DQ21	94	V _{DD}	146	V _{SS}	198	EVENT#
43	DQS2#	95	A12	147	DQ35	199	V _{DDSPD}	44	DM2	96	A11	148	DQ44	200	SDA
45	DQS2	97	A8	149	V _{SS}	201	SA1	46	V _{SS}	98	A7	150	DQ45	202	SCL
47	V _{SS}	99	A5	151	DQ40	203	V _{TT}	48	DQ22	100	A6	152	V _{SS}	204	V _{TT}
49	DQ18	101	V _{DD}	153	DQ41	-	-	50	DQ23	102	V _{DD}	154	DQS5#	-	-
51	DQ19	103	A3	155	V _{SS}	-	-	52	V _{SS}	104	A4	156	DQS5	-	-

Pin Descriptions

The pin description table below is a comprehensive list of all possible pins for all DDR3 modules. All pins listed may not be supported on this module. See Pin Assignments for information specific to this module.

Table 5: Pin Descriptions

Symbol	Type	Description
Ax	Input	Address inputs: Provide the row address for ACTIVE commands, and the column address and auto precharge bit (A10) for READ/WRITE commands, to select one location out of the memory array in the respective bank. A10 sampled during a PRECHARGE command determines whether the PRECHARGE applies to one bank (A10 LOW, bank selected by BAx) or all banks (A10 HIGH). The address inputs also provide the op-code during a LOAD MODE command. See the Pin Assignments table for density-specific addressing information.
BAx	Input	Bank address inputs: Define the device bank to which an ACTIVE, READ, WRITE, or PRECHARGE command is being applied. BA define which mode register (MR0, MR1, MR2, or MR3) is loaded during the LOAD MODE command.
CKx, CKx#	Input	Clock: Differential clock inputs. All control, command, and address input signals are sampled on the crossing of the positive edge of CK and the negative edge of CK#.
CKEx	Input	Clock enable: Enables (registered HIGH) and disables (registered LOW) internal circuitry and clocks on the DRAM.
DMx	Input	Data mask (x8 devices only): DM is an input mask signal for write data. Input data is masked when DM is sampled HIGH, along with that input data, during a write access. Although DM pins are input-only, DM loading is designed to match that of the DQ and DQS pins.
ODTx	Input	On-die termination: Enables (registered HIGH) and disables (registered LOW) termination resistance internal to the DDR3 SDRAM. When enabled in normal operation, ODT is only applied to the following pins: DQ, DQS, DQS#, DM, and CB. The ODT input will be ignored if disabled via the LOAD MODE command.
Par_In	Input	Parity input: Parity bit for Ax, RAS#, CAS#, and WE#.
RAS#, CAS#, WE#	Input	Command inputs: RAS#, CAS#, and WE# (along with S#) define the command being entered.
RESET#	Input (LVCMOS)	Reset: RESET# is an active LOW asynchronous input that is connected to each DRAM and the registering clock driver. After RESET# goes HIGH, the DRAM must be reinitialized as though a normal power-up was executed.
Sx#	Input	Chip select: Enables (registered LOW) and disables (registered HIGH) the command decoder.
SAx	Input	Serial address inputs: Used to configure the temperature sensor/SPD EEPROM address range on the I ² C bus.
SCL	Input	Serial clock for temperature sensor/SPD EEPROM: Used to synchronize communication to and from the temperature sensor/SPD EEPROM on the I ² C bus.
CBx	I/O	Check bits: Used for system error detection and correction.
DQx	I/O	Data input/output: Bidirectional data bus.
DQSx, DQSx#	I/O	Data strobe: Differential data strobes. Output with read data; edge-aligned with read data; input with write data; center-aligned with write data.

Table 5: Pin Descriptions (Continued)

Symbol	Type	Description
SDA	I/O	Serial data: Used to transfer addresses and data into and out of the temperature sensor/SPD EEPROM on the I ² C bus.
TDQSx, TDQSx#	Output	Redundant data strobe (x8 devices only): TDQS is enabled/disabled via the LOAD MODE command to the extended mode register (EMR). When TDQS is enabled, DM is disabled and TDQS and TDQS# provide termination resistance; otherwise, TDQS# are no function.
Err_Out#	Output (open drain)	Parity error output: Parity error found on the command and address bus.
EVENT#	Output (open drain)	Temperature event: The EVENT# pin is asserted by the temperature sensor when critical temperature thresholds have been exceeded.
V _{DD}	Supply	Power supply: 1.35V (1.283–1.45V) backward-compatible to 1.5V (1.425–1.575V). The component V _{DD} and V _{DDQ} are connected to the module V _{DD} .
V _{DDSPD}	Supply	Temperature sensor/SPD EEPROM power supply: 3.0–3.6V.
V _{REFCA}	Supply	Reference voltage: Control, command, and address V _{DD} /2.
V _{REFDQ}	Supply	Reference voltage: DQ, DM V _{DD} /2.
V _{SS}	Supply	Ground.
V _{TT}	Supply	Termination voltage: Used for control, command, and address V _{DD} /2.
NC	–	No connect: These pins are not connected on the module.
NF	–	No function: These pins are connected within the module, but provide no functionality.



DQ Map

Table 6: Component-to-Module DQ Map, Front

Component Reference Number	Component DQ	Module DQ	Module Pin Number	Component Reference Number	Component DQ	Module DQ	Module Pin Number
U1	0	2	13	U2	0	23	50
	1	0	5		1	21	42
	2	3	15		2	19	51
	3	5	6		3	20	40
	4	7	18		4	22	48
	5	4	4		5	16	37
	6	6	16		6	18	49
	7	1	7		7	17	39
U3	0	CB2	81	U4	0	42	159
	1	CB1	71		1	45	150
	2	CB3	83		2	46	160
	3	CB4	72		3	40	151
	4	CB6	80		4	43	161
	5	CB0	69		5	44	148
	6	CB7	82		6	47	162
	7	CB5	74		7	41	153
U5	0	59	193	U6	0	14	34
	1	57	185		1	9	21
	2	62	192		2	11	33
	3	56	183		3	8	19
	4	58	191		4	10	31
	5	61	182		5	13	24
	6	63	194		6	15	36
	7	60	180		7	12	22
U7	0	29	56	U8	0	38	142
	1	26	63		1	33	135
	2	28	54		2	35	147
	3	31	68		3	37	136
	4	25	57		4	39	144
	5	27	65		5	32	133
	6	24	55		6	34	145
	7	30	66		7	36	134



Table 6: Component-to-Module DQ Map, Front (Continued)

Component Reference Number	Component DQ	Module DQ	Module Pin Number	Component Reference Number	Component DQ	Module DQ	Module Pin Number
U9	0	55	176	U10	0	57	185
	1	53	168		1	59	193
	2	54	174		2	56	183
	3	52	166		3	62	192
	4	51	179		4	60	180
	5	48	165		5	63	194
	6	50	177		6	61	182
	7	49	167		7	58	191

Table 7: Component-to-Module DQ Map, Back

Component Reference Number	Component DQ	Module DQ	Module Pin Number	Component Reference Number	Component DQ	Module DQ	Module Pin Number
U11	0	45	150	U12	0	CB1	71
	1	42	159		1	CB2	81
	2	40	151		2	CB4	72
	3	46	160		3	CB3	83
	4	41	153		4	CB5	74
	5	47	162		5	CB7	82
	6	44	148		6	CB0	69
	7	43	161		7	CB6	80
U13	0	21	42	U14	0	0	5
	1	23	50		1	2	13
	2	20	40		2	5	6
	3	19	51		3	3	15
	4	17	39		4	1	7
	5	18	49		5	6	16
	6	16	37		6	4	4
	7	22	48		7	7	18

Table 7: Component-to-Module DQ Map, Back (Continued)

Component Reference Number	Component DQ	Module DQ	Module Pin Number	Component Reference Number	Component DQ	Module DQ	Module Pin Number
U16	0	53	168	U17	0	33	135
	1	55	176		1	38	142
	2	52	166		2	37	136
	3	54	174		3	35	147
	4	49	167		4	36	134
	5	50	177		5	34	145
	6	48	165		6	32	133
	7	51	179		7	39	144
U18	0	26	63	U19	0	9	21
	1	29	56		1	14	34
	2	31	68		2	8	19
	3	28	54		3	11	33
	4	30	66		4	12	22
	5	24	55		5	15	36
	6	27	65		6	13	24
	7	25	57		7	10	31

Functional Block Diagram

Figure 2: Functional Block Diagram

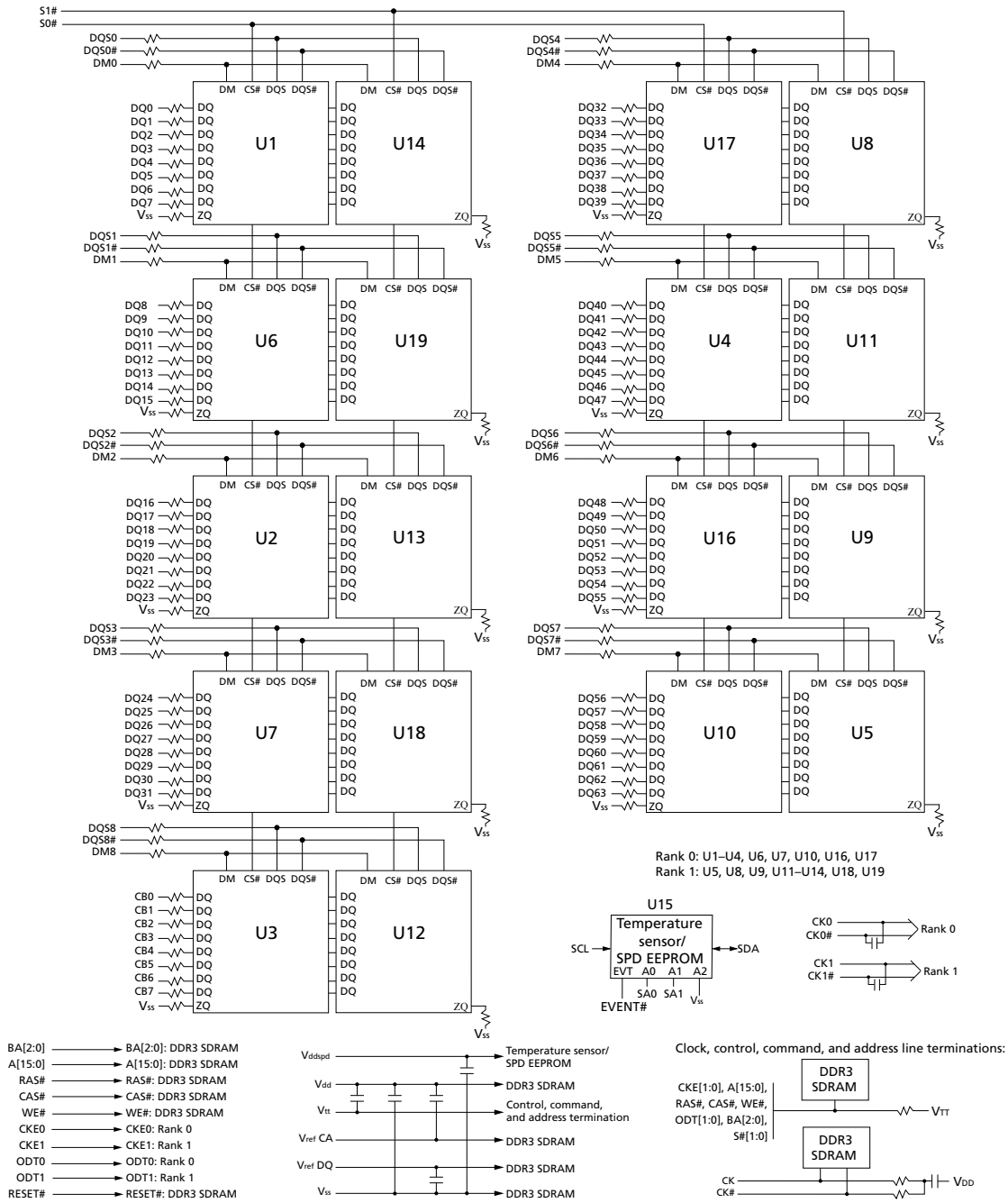

Note: 1. The ZQ ball on each DDR3 component is connected to an external 240Ω ±1% resistor that is tied to ground. It is used for the calibration of the component's ODT and output driver.

General Description

DDR3 SDRAM modules are high-speed, CMOS dynamic random access memory modules that use internally configured 8-bank DDR3 SDRAM devices. DDR3 SDRAM modules use DDR architecture to achieve high-speed operation. DDR3 architecture is essentially an $8n$ -prefetch architecture with an interface designed to transfer two data words per clock cycle at the I/O pins. A single read or write access for the DDR3 SDRAM module effectively consists of a single $8n$ -bit-wide, one-clock-cycle data transfer at the internal DRAM core and eight corresponding n -bit-wide, one-half-clock-cycle data transfers at the I/O pins.

DDR3 modules use two sets of differential signals: DQS, DQS# to capture data and CK and CK# to capture commands, addresses, and control signals. Differential clocks and data strobes ensure exceptional noise immunity for these signals and provide precise crossing points to capture input signals.

Fly-By Topology

DDR3 modules use faster clock speeds than earlier DDR technologies, making signal quality more important than ever. For improved signal quality, the clock, control, command, and address buses have been routed in a fly-by topology, where each clock, control, command, and address pin on each DRAM is connected to a single trace and terminated (rather than a tree structure, where the termination is off the module near the connector). Inherent to fly-by topology, the timing skew between the clock and DQS signals can be easily accounted for by using the write-leveling feature of DDR3.

Temperature Sensor with Serial Presence-Detect EEPROM

Thermal Sensor Operations

The temperature from the integrated thermal sensor is monitored and converts into a digital word via the I²C bus. System designers can use the user-programmable registers to create a custom temperature-sensing solution based on system requirements. Programming and configuration details comply with JEDEC standard No. 21-C page 4.7-1, "Definition of the TSE2002av, Serial Presence Detect with Temperature Sensor."

Serial Presence-Detect EEPROM Operation

DDR3 SDRAM modules incorporate serial presence-detect. The SPD data is stored in a 256-byte EEPROM. The first 128 bytes are programmed by Micron to comply with JEDEC standard JC-45, "Appendix X: Serial Presence Detect (SPD) for DDR3 SDRAM Modules." These bytes identify module-specific timing parameters, configuration information, and physical attributes. The remaining 128 bytes of storage are available for use by the customer. System READ/WRITE operations between the master (system logic) and the slave EEPROM device occur via a standard I²C bus using the DIMM's SCL (clock) SDA (data), and SA (address) pins. Write protect (WP) is connected to V_{SS}, permanently disabling hardware write protection. For further information refer to Micron technical note TN-04-42, "Memory Module Serial Presence-Detect."

Electrical Specifications

Stresses greater than those listed may cause permanent damage to the module. This is a stress rating only, and functional operation of the module at these or any other conditions outside those indicated in each device's data sheet is not implied. Exposure to absolute maximum rating conditions for extended periods may adversely affect reliability.

Table 8: Absolute Maximum Ratings

Symbol	Parameter	Min	Max	Units
V_{DD}	V_{DD} supply voltage relative to V_{SS}	-0.4	1.975	V
V_{IN}, V_{OUT}	Voltage on any pin relative to V_{SS}	-0.4	1.975	V

Table 9: Operating Conditions

Symbol	Parameter	Min	Nom	Max	Units	Notes	
V_{DD}	V_{DD} supply voltage	1.283	1.35	1.45	V		
		1.425	1.5	1.575	V	1	
$V_{REFCA(DC)}$	Input reference voltage command/address bus	$0.49 \times V_{DD}$	$0.5 \times V_{DD}$	$0.51 \times V_{DD}$	V		
$V_{REFDQ(DC)}$	I/O reference voltage DQ bus	$0.49 \times V_{DD}$	$0.5 \times V_{DD}$	$0.51 \times V_{DD}$	V		
I_{VTT}	Termination reference current from V_{TT}	-600	-	600	mA		
V_{TT}	Termination reference voltage (DC) – command/address bus	$0.49 \times V_{DD} - 20mV$	$0.5 \times V_{DD}$	$0.51 \times V_{DD} + 20mV$	V	2	
I_I	Input leakage current; Any input $0V \leq V_{IN} \leq V_{DD}$; V_{REF} input $0V \leq V_{IN} \leq 0.95V$ (All other pins not under test = 0V)	Address inputs, RAS#, CAS#, WE#, BA	-36	0	36	μA	
		S#, CKE, ODT, CK, CK#	-18	0	18		
		DM	-4	0	4		
I_{OZ}	Output leakage current; $0V \leq V_{OUT} \leq V_{DD}$; DQ and ODT are disabled; ODT is HIGH	DQ, DQS, DQS#, CB	-10	0	10	μA	
I_{VREF}	V_{REF} supply leakage current; $V_{REFDQ} = V_{DD}/2$ or $V_{REFCA} = V_{DD}/2$ (All other pins not under test = 0V)	-18	0	18	μA		
T_A	Module ambient operating temperature	0	-	70	$^{\circ}C$	3, 4	
T_C	DDR3 SDRAM component case operating temperature	0	-	95	$^{\circ}C$	3, 4, 5	

- Notes:
- Module is backward-compatible with 1.5V operation. Refer to device specification for details and operation guidance.
 - V_{TT} termination voltage in excess of the stated limit will adversely affect the command and address signals' voltage margin and will reduce timing margins.
 - T_A and T_C are simultaneous requirements.
 - For further information, refer to technical note TN-00-08: "Thermal Applications," available on Micron's web site.
 - The refresh rate is required to double when $85^{\circ}C < T_C \leq 95^{\circ}C$.

DRAM Operating Conditions

Recommended AC operating conditions are given in the DDR3 component data sheets. Component specifications are available at micron.com. Module speed grades correlate with component speed grades, as shown below.

Table 10: Module and Component Speed Grades

DDR3 components may exceed the listed module speed grades; module may not be available in all listed speed grades

Module Speed Grade	Component Speed Grade
-2G1	-093
-1G9	-107
-1G6	-125
-1G4	-15E
-1G1	-187E
-1G0	-187
-80C	-25E
-80B	-25

Design Considerations

Simulations

Micron memory modules are designed to optimize signal integrity through carefully designed terminations, controlled board impedances, routing topologies, trace length matching, and decoupling. However, good signal integrity starts at the system level. Micron encourages designers to simulate the signal characteristics of the system's memory bus to ensure adequate signal integrity of the entire memory system.

Power

Operating voltages are specified at the DRAM, not at the edge connector of the module. Designers must account for any system voltage drops at anticipated power levels to ensure the required supply voltage is maintained.

I_{DD} Specifications

Table 11: DDR3 I_{DD} Specifications and Conditions – 16GB (Die Revision A)

Values are for the MT41K1G8 DDR3L SDRAM only and are computed from values specified in the 8Gb 1.35V (1 Gig x 8) component data sheet

Parameter	Symbol	1866	1600	Units
Operating current 0: One bank ACTIVATE-to-PRECHARGE	I _{DD0} ¹	720	702	mA
Operating current 1: One bank ACTIVATE-to-READ-to-PRECHARGE	I _{DD1} ¹	828	801	mA
Precharge power-down current: Slow exit	I _{DD2P0} ²	198	198	mA
Precharge power-down current: Fast exit	I _{DD2P1} ²	288	252	mA
Precharge quiet standby current	I _{DD2Q} ²	648	612	mA
Precharge standby current	I _{DD2N} ²	684	648	mA
Precharge standby ODT current	I _{DD2NT} ¹	477	459	mA
Active power-down current	I _{DD3P} ²	684	648	mA
Active standby current	I _{DD3N} ²	954	918	mA
Burst read operating current	I _{DD4R} ¹	1314	1224	mA
Burst write operating current	I _{DD4W} ¹	1314	1224	mA
Refresh current	I _{DD5B} ¹	2349	2304	mA
Self refresh temperature current: MAX T _C = 85°C	I _{DD6} ²	432	432	mA
Self refresh temperature current (SRT-enabled): MAX T _C = 95°C	I _{DD6ET} ²	612	612	mA
All banks interleaved read current	I _{DD7} ¹	1899	1809	mA
Reset current	I _{DD8} ²	234	234	mA

- Notes: 1. One module rank in the active I_{DD}, the other rank in I_{DD2P0}.
2. All ranks in this I_{DD} condition.



Temperature Sensor with Serial Presence-Detect EEPROM

The temperature sensor continuously monitors the module's temperature and can be read back at any time over the I²C bus shared with the SPD EEPROM. Refer to JEDEC standard No. 21-C page 4.7-1, "Definition of the TSE2002av, Serial Presence Detect with Temperature Sensor."

Serial Presence-Detect

For the latest SPD data, refer to Micron's SPD page: micron.com/SPD.

Table 12: Temperature Sensor with SPD EEPROM Operating Conditions

Parameter/Condition	Symbol	Min	Max	Units
Supply voltage	V _{DDSPD}	3.0	3.6	V
Supply current: V _{DD} = 3.3V	I _{DD}	–	2.0	mA
Input high voltage: Logic 1; SCL, SDA	V _{IH}	V _{DDSPD} × 0.7	V _{DDSPD} + 1	V
Input low voltage: Logic 0; SCL, SDA	V _{IL}	–0.5	V _{DDSPD} × 0.3	V
Output low voltage: I _{OUT} = 2.1mA	V _{OL}	–	0.4	V
Input current	I _{IN}	–5.0	5.0	μA
Temperature sensing range	–	–40	125	°C
Temperature sensor accuracy (class B)	–	–1.0	1.0	°C

Table 13: Temperature Sensor and SPD EEPROM Serial Interface Timing

Parameter/Condition	Symbol	Min	Max	Units
Time bus must be free before a new transition can start	t _{BUF}	4.7	–	μs
SDA fall time	t _F	20	300	ns
SDA rise time	t _R	–	1000	ns
Data hold time	t _{HD:DAT}	200	900	ns
Start condition hold time	t _{H:STA}	4.0	–	μs
Clock HIGH period	t _{HIGH}	4.0	50	μs
Clock LOW period	t _{LOW}	4.7	–	μs
SCL clock frequency	t _{SCL}	10	100	kHz
Data setup time	t _{SU:DAT}	250	–	ns
Start condition setup time	t _{SU:STA}	4.7	–	μs
Stop condition setup time	t _{SU:STO}	4.0	–	μs

EVENT# Pin

The temperature sensor also adds the EVENT# pin (open-drain). Not used by the SPD EEPROM, EVENT# is a temperature sensor output used to flag critical events that can be set up in the sensor's configuration register.

EVENT# has three defined modes of operation: interrupt mode, compare mode, and critical temperature mode. Event thresholds are programmed in the 0x01 register using a hysteresis. The alarm window provides a comparison window, with upper and lower limits set in the alarm upper boundary register and the alarm lower boundary register, respectively. When the alarm window is enabled, EVENT# will trigger whenever the temperature is outside the MIN or MAX values set by the user.

The interrupt mode enables software to reset EVENT# after a critical temperature threshold has been detected. Threshold points are set in the configuration register by the user. This mode triggers the critical temperature limit and both the MIN and MAX of the temperature window.

The compare mode is similar to the interrupt mode, except EVENT# cannot be reset by the user and returns to the logic HIGH state only when the temperature falls below the programmed thresholds.

Critical temperature mode triggers EVENT# only when the temperature has exceeded the programmed critical trip point. When the critical trip point has been reached, the temperature sensor goes into comparator mode, and the critical EVENT# cannot be cleared through software.

Module Dimensions

Figure 3: 204-Pin DDR3 SODIMM

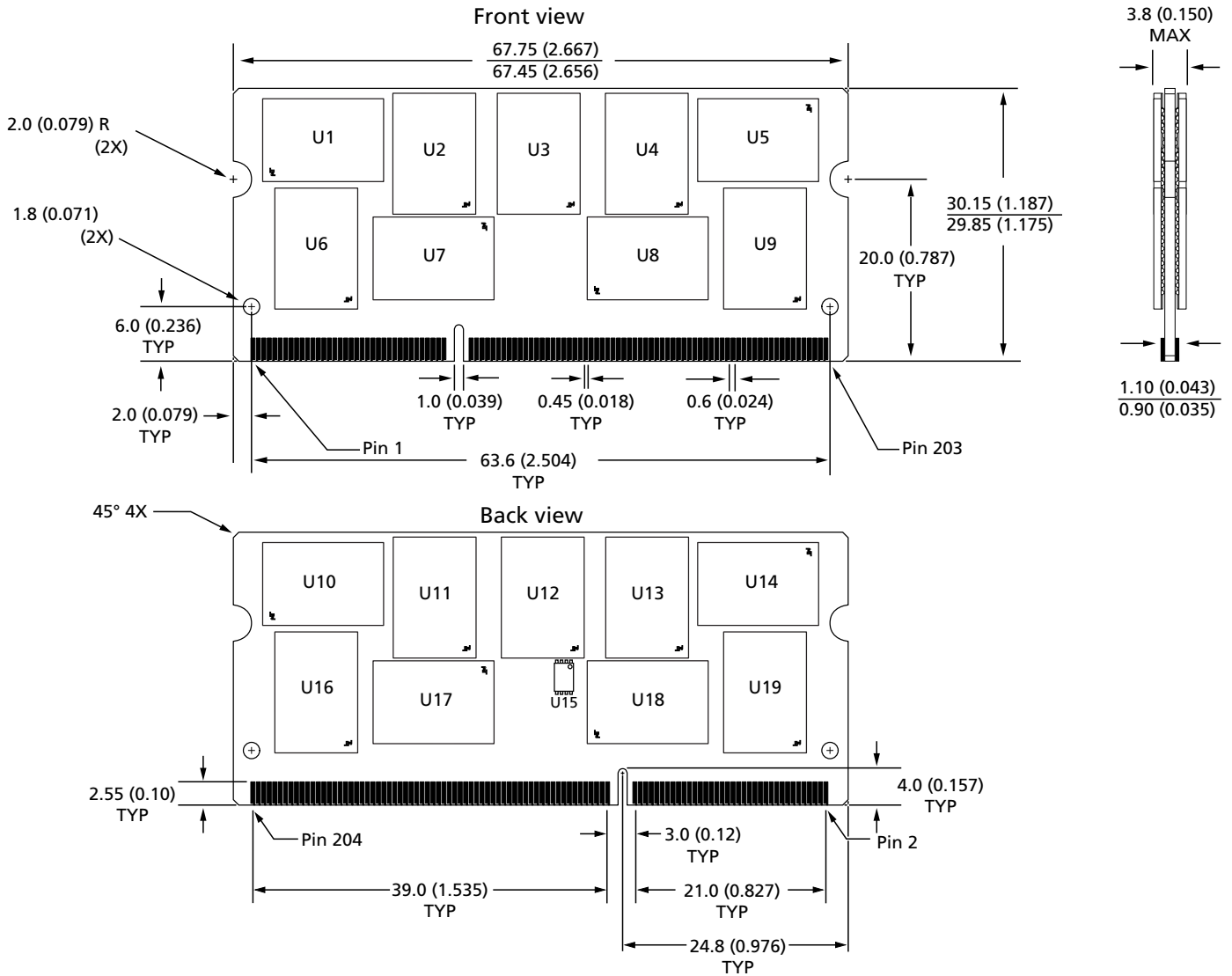

- Notes: 1. All dimensions are in millimeters (inches); MAX/MIN or typical (TYP) where noted.
2. The dimensional diagram is for reference only.

8000 S. Federal Way, P.O. Box 6, Boise, ID 83707-0006, Tel: 208-368-4000
www.micron.com/products/support Sales inquiries: 800-932-4992
 Micron and the Micron logo are trademarks of Micron Technology, Inc.
 All other trademarks are the property of their respective owners.

This data sheet contains minimum and maximum limits specified over the power supply and temperature range set forth herein. Although considered final, these specifications are subject to change, as further product development and data characterization sometimes occur.