



Chipsmall Limited consists of a professional team with an average of over 10 year of expertise in the distribution of electronic components. Based in Hongkong, we have already established firm and mutual-benefit business relationships with customers from,Europe,America and south Asia,supplying obsolete and hard-to-find components to meet their specific needs.

With the principle of “Quality Parts,Customers Priority,Honest Operation,and Considerate Service”,our business mainly focus on the distribution of electronic components. Line cards we deal with include Microchip,ALPS,ROHM,Xilinx,Pulse,ON,Everlight and Freescale. Main products comprise IC,Modules,Potentiometer,IC Socket,Relay,Connector.Our parts cover such applications as commercial,industrial, and automotives areas.

We are looking forward to setting up business relationship with you and hope to provide you with the best service and solution. Let us make a better world for our industry!



Contact us

Tel: +86-755-8981 8866 Fax: +86-755-8427 6832

Email & Skype: info@chipsmall.com Web: www.chipsmall.com

Address: A1208, Overseas Decoration Building, #122 Zhenhua RD., Futian, Shenzhen, China



Mobile Low-Power DDR SDRAM

MT46H8M16LF – 2 Meg x 16 x 4 Banks
MT46H4M32LF – 1 Meg x 32 x 4 Banks

Features

- $V_{DD}/V_{DDQ} = 1.70\text{--}1.95\text{V}$
- Bidirectional data strobe per byte of data (DQS)
- Internal, pipelined double data rate (DDR) architecture; two data accesses per clock cycle
- Differential clock inputs (CK and CK#)
- Commands entered on each positive CK edge
- DQS edge-aligned with data for READs; center-aligned with data for WRITEs
- 4 internal banks for concurrent operation
- Data masks (DM) for masking write data; one mask per byte
- Programmable burst lengths (BL): 2, 4, 8, or 16
- Concurrent auto precharge option is supported
- Auto refresh and self refresh modes
- 1.8V LVCMOS-compatible inputs
- Temperature-compensated self refresh (TCSR)
- Partial-array self refresh (PASR)
- Deep power-down (DPD)
- Status read register (SRR)
- Selectable output drive strength (DS)
- Clock stop capability
- 64ms refresh

Options

- V_{DD}/V_{DDQ}
 - 1.8V/1.8V H
- Configuration
 - 8 Meg x 16 (2 Meg x 16 x 4 banks) 8M16
 - 4 Meg x 32 (1 Meg x 32 x 4 banks) 4M32
- Row size option
 - JEDEC-standard option LF
- Plastic "green" package
 - 60-ball VFBGA (8mm x 9mm)¹ BF
 - 90-ball VFBGA (8mm x 13mm)² B5
- Timing – cycle time
 - 5ns @ CL = 3 (200 MHz) -5
 - 5.4ns @ CL = 3 (185 MHz) -54
 - 6ns @ CL = 3 (166 MHz) -6
 - 7.5ns @ CL = 3 (133 MHz) -75
- Operating temperature range
 - Commercial (0° to +70°C) None
 - Industrial (–40°C to +85°C) IT
- Design revision :K

Notes: 1. Only available for x16 configuration.
2. Only available for x32 configuration.

Table 1: Key Timing Parameters (CL = 3)

Speed Grade	Clock Rate	Access Time
-5	200 MHz	5.0ns
-54	185 MHz	5.0ns
-6	166 MHz	5.0ns
-75	133 MHz	6.0ns

Table 2: Configuration Addressing

Architecture	8 Meg x 16	4 Meg x 32
Configuration	2 Meg x 16 x 4 banks	1 Meg x 32 x 4 banks
Refresh count	4K	4K
Row addressing	4K A[11:0]	4K A[11:0]
Column addressing	512 A[8:0]	256 A[7:0]

Figure 1: 128Mb Mobile LPDDR Part Numbering

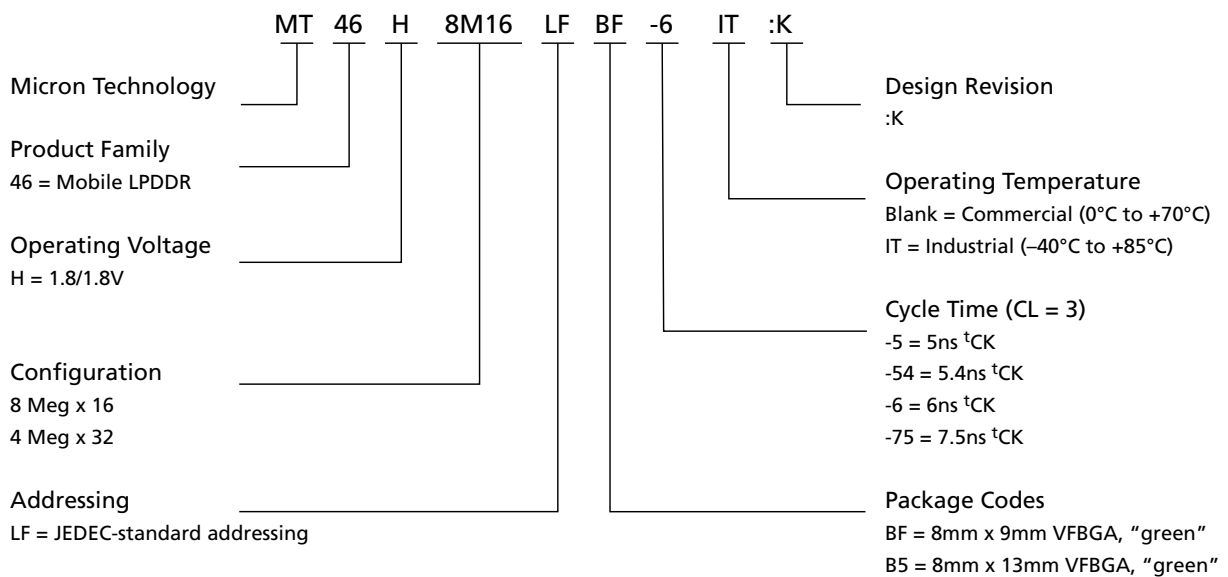

FBGA Part Marking Decoder

Due to space limitations, FBGA-packaged components have an abbreviated part marking that is different from the part number. Micron's FBGA part marking decoder is available at www.micron.com/decoder.



Contents

General Description	8
Functional Block Diagrams	9
Ball Assignments	11
Ball Descriptions	13
Package Dimensions	15
Electrical Specifications	17
Electrical Specifications – I _{DD} Parameters	20
Electrical Specifications – AC Operating Conditions	24
Output Drive Characteristics	29
Functional Description	32
Commands	33
DESELECT	34
NO OPERATION	34
LOAD MODE REGISTER	34
ACTIVE	34
READ	35
WRITE	36
PRECHARGE	37
BURST TERMINATE	38
AUTO REFRESH	38
SELF REFRESH	39
DEEP POWER-DOWN	39
Truth Tables	40
State Diagram	45
Initialization	46
Standard Mode Register	49
Burst Length	50
Burst Type	50
CAS Latency	51
Operating Mode	52
Extended Mode Register	53
Temperature-Compensated Self Refresh	53
Partial-Array Self Refresh	54
Output Drive Strength	54
Status Read Register	55
Bank/Row Activation	57
READ Operation	58
WRITE Operation	69
PRECHARGE Operation	81
Auto Precharge	81
Concurrent Auto Precharge	82
AUTO REFRESH Operation	87
SELF REFRESH Operation	88
Power-Down	89
Deep Power-Down	91
Clock Change Frequency	93
Revision History	94
Rev. F, Production – 02/10	94
Rev. E, Production – 8/09	94
Rev. D, Production – 04/09	94



128Mb: x16, x32 Mobile LPDDR SDRAM Features

Rev. C, Production – 10/08	94
Rev. B, Preliminary – 05/08	94
Rev. A, Advance – 04/08	94



List of Tables

Table 1: Key Timing Parameters (CL = 3)	1
Table 2: Configuration Addressing	2
Table 3: Ball Descriptions	13
Table 4: Absolute Maximum Ratings	17
Table 5: AC/DC Electrical Characteristics and Operating Conditions	17
Table 6: Capacitance (x16, x32)	19
Table 7: I _{DD} Specifications and Conditions (x16)	20
Table 8: I _{DD} Specifications and Conditions (x32)	21
Table 9: I _{DD6} Specifications and Conditions	22
Table 10: Electrical Characteristics and Recommended AC Operating Conditions	24
Table 11: Target Output Drive Characteristics (Full Strength)	29
Table 12: Target Output Drive Characteristics (Three-Quarter Strength)	30
Table 13: Target Output Drive Characteristics (One-Half Strength)	31
Table 14: Truth Table – Commands	33
Table 15: DM Operation Truth Table	34
Table 16: Truth Table – Current State Bank <i>n</i> – Command to Bank <i>n</i>	40
Table 17: Truth Table – Current State Bank <i>n</i> – Command to Bank <i>m</i>	42
Table 18: Truth Table – CKE	44
Table 19: Burst Definition Table	50

List of Figures

Figure 1: 128Mb Mobile LPDDR Part Numbering	2
Figure 2: Functional Block Diagram (x16)	9
Figure 3: Functional Block Diagram (x32)	10
Figure 4: 60-Ball VFBGA – Top View, x16 only	11
Figure 5: 90-Ball VFBGA – Top View, x32 only	12
Figure 6: 60-Ball VFBGA (8mm x 9mm), Package code: BF	15
Figure 7: 90-Ball VFBGA (8mm x 13mm), Package code: B5	16
Figure 8: Typical Self Refresh Current vs. Temperature	23
Figure 9: ACTIVE Command	35
Figure 10: READ Command	36
Figure 11: WRITE Command	37
Figure 12: PRECHARGE Command	38
Figure 13: DEEP POWER-DOWN Command	39
Figure 14: Simplified State Diagram	45
Figure 15: Initialize and Load Mode Registers	47
Figure 16: Alternate Initialization with CKE LOW	48
Figure 17: Standard Mode Register Definition	49
Figure 18: CAS Latency	52
Figure 19: Extended Mode Register	53
Figure 20: Status Read Register Timing	55
Figure 21: Status Register Definition	56
Figure 22: READ Burst	59
Figure 23: Consecutive READ Bursts	60
Figure 24: Nonconsecutive READ Bursts	61
Figure 25: Random Read Accesses	62
Figure 26: Terminating a READ Burst	63
Figure 27: READ-to-WRITE	64
Figure 28: READ-to-PRECHARGE	65
Figure 29: Data Output Timing – t_{DQSQ} , t_{QH} , and Data Valid Window (x16)	66
Figure 30: Data Output Timing – t_{DQSQ} , t_{QH} , and Data Valid Window (x32)	67
Figure 31: Data Output Timing – t_{AC} and t_{DQSC}	68
Figure 32: Data Input Timing	70
Figure 33: Write – DM Operation	71
Figure 34: WRITE Burst	72
Figure 35: Consecutive WRITE-to-WRITE	73
Figure 36: Nonconsecutive WRITE-to-WRITE	73
Figure 37: Random WRITE Cycles	74
Figure 38: WRITE-to-READ – Uninterrupting	75
Figure 39: WRITE-to-READ – Interrupting	76
Figure 40: WRITE-to-READ – Odd Number of Data, Interrupting	77
Figure 41: WRITE-to-PRECHARGE – Uninterrupting	78
Figure 42: WRITE-to-PRECHARGE – Interrupting	79
Figure 43: WRITE-to-PRECHARGE – Odd Number of Data, Interrupting	80
Figure 44: Bank Read – With Auto Precharge	83
Figure 45: Bank Read – Without Auto Precharge	84
Figure 46: Bank Write – With Auto Precharge	85
Figure 47: Bank Write – Without Auto Precharge	86
Figure 48: Auto Refresh Mode	87
Figure 49: Self Refresh Mode	89
Figure 50: Power-Down Entry (in Active or Precharge Mode)	90



Figure 51: Power-Down Mode (Active or Precharge) 91
Figure 52: Deep Power-Down Mode 92
Figure 53: Clock Stop Mode 93

General Description

The 128Mb Mobile DDR SDRAM is a high-speed CMOS, dynamic random-access memory containing 134,217,728 bits. It is internally configured as a quad-bank DRAM. Each of the x16's 33,554,432-bit banks is organized as 4096 rows by 512 columns by 16 bits. Each of the x32's 33,554,432-bit banks is organized as 4096 rows by 256 columns by 32 bits.

Note:

1. Throughout this data sheet, various figures and text refer to DQs as "DQ." DQ should be interpreted as any and all DQ collectively, unless specifically stated otherwise. Additionally, the x16 is divided into 2 bytes: the lower byte and the upper byte. For the lower byte (DQ[7:0]), DM refers to LDM and DQS refers to LDQS. For the upper byte (DQ[15:8]), DM refers to UDM and DQS refers to UDQS. The x32 is divided into 4 bytes. For DQ[7:0], DM refers to DM0 and DQS refers to DQS0. For DQ[15:8], DM refers to DM1 and DQS refers to DQS1. For DQ[23:16], DM refers to DM2 and DQS refers to DQS2. For DQ[31:24], DM refers to DM3 and DQS refers to DQS3.
2. Complete functionality is described throughout the document; any page or diagram may have been simplified to convey a topic and may not be inclusive of all requirements.
3. Any specific requirement takes precedence over a general statement.

Functional Block Diagrams

Figure 2: Functional Block Diagram (x16)

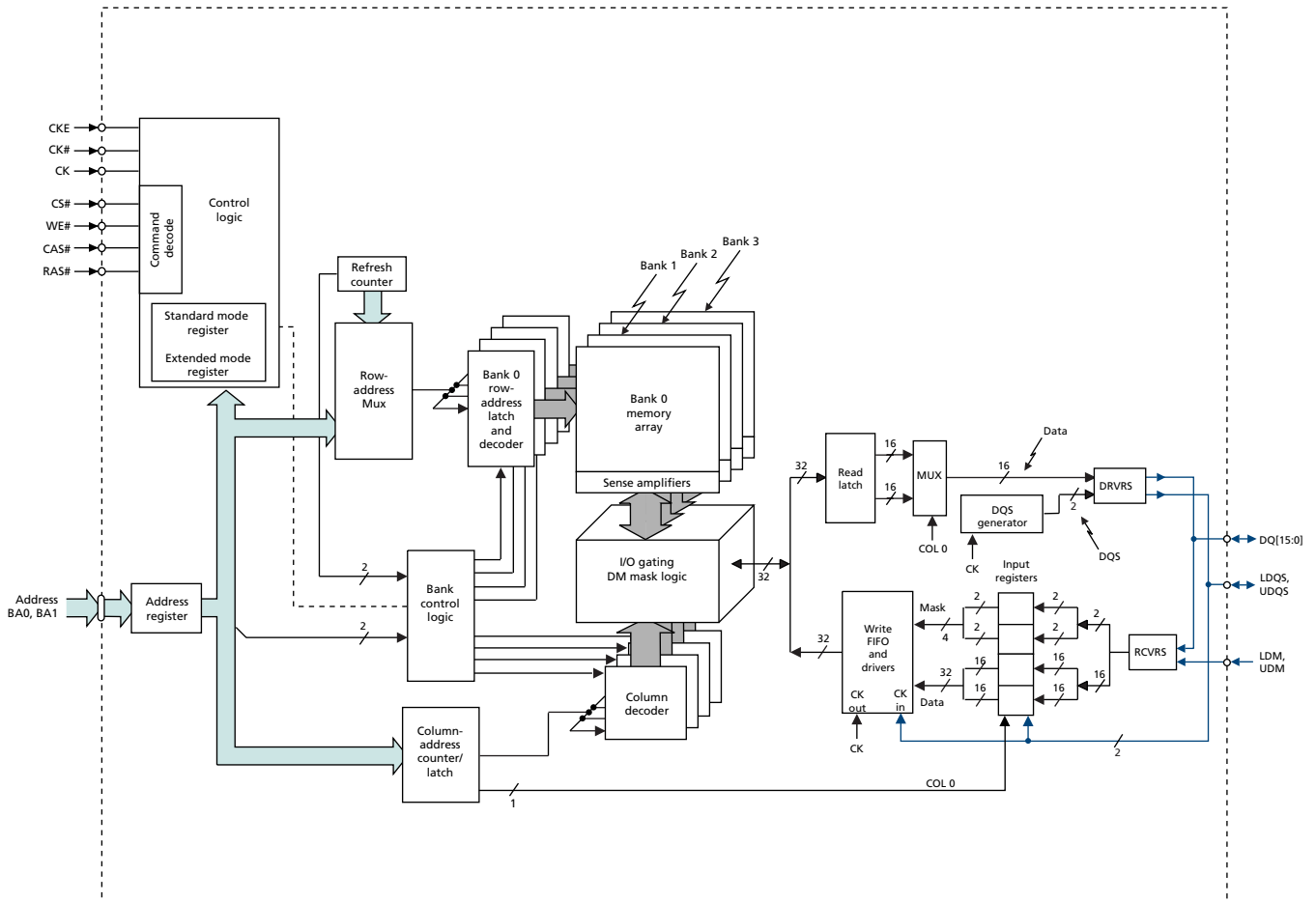
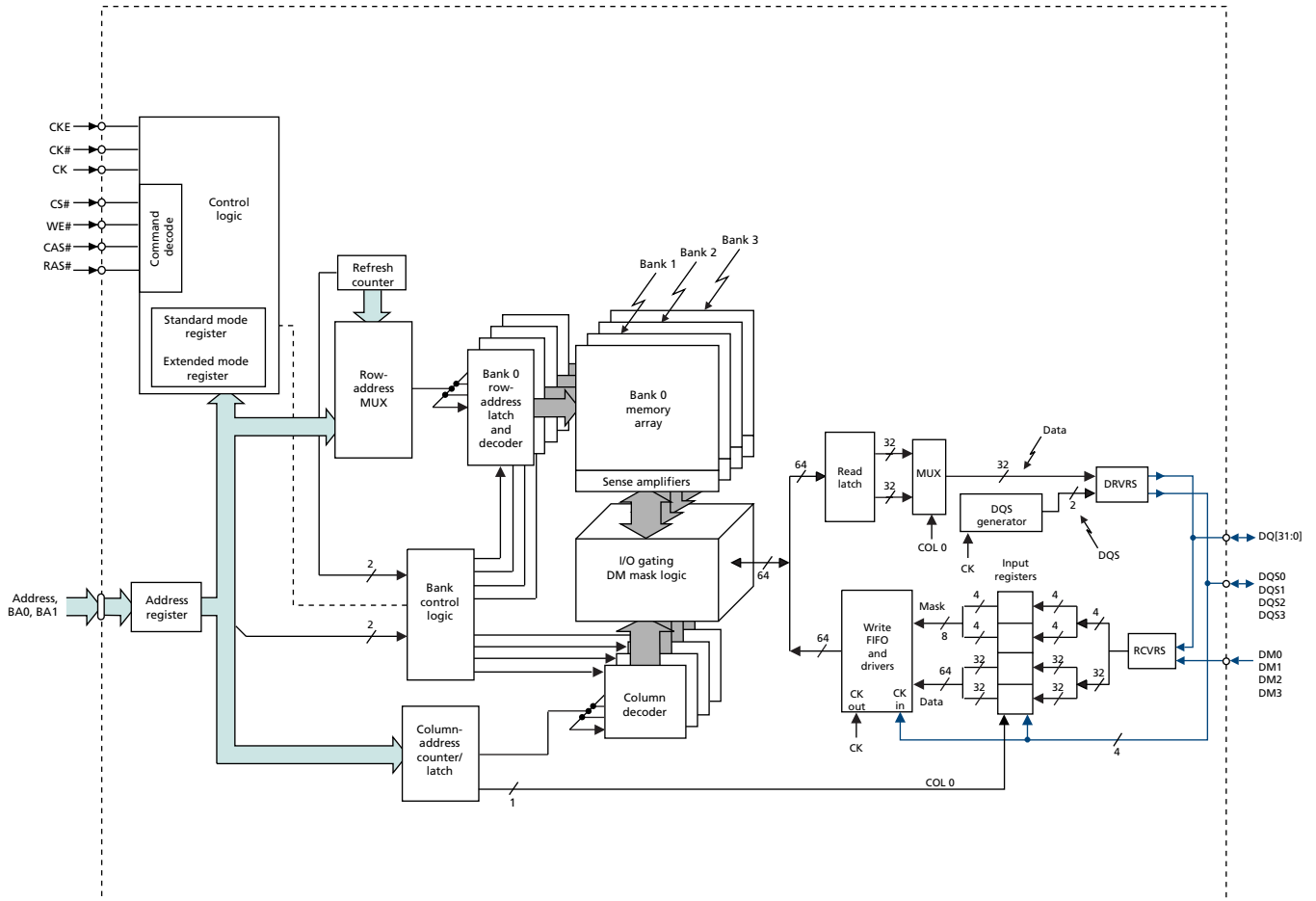
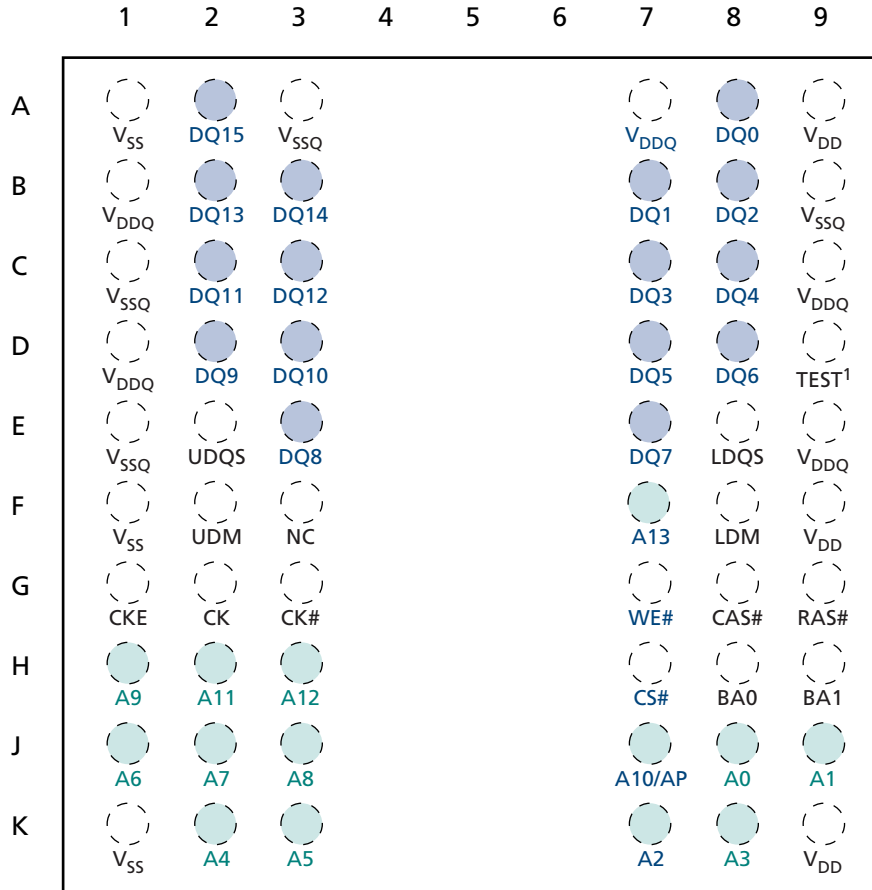

Figure 3: Functional Block Diagram (x32)



Ball Assignments

Figure 4: 60-Ball VFBGA – Top View, x16 only



- Notes:
1. D9 is a test pin that must be tied to V_{SS} or V_{SSQ} in normal operations.
 2. Unused address pins become RFU.

Figure 5: 90-Ball VFBGA – Top View, x32 only

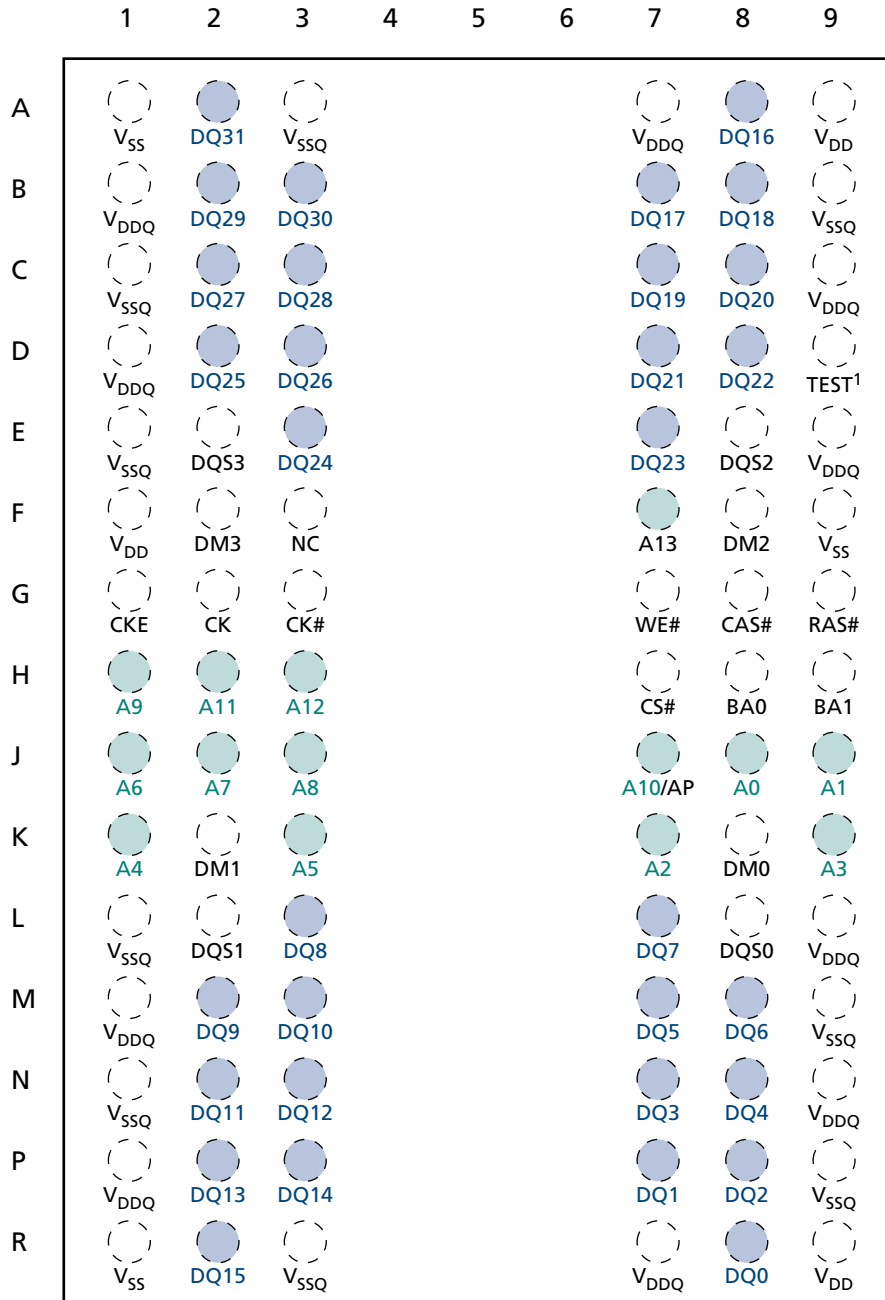

- Notes:
1. D9 is a test pin that must be tied to V_{SS} or V_{SSQ} in normal operations.
 2. Unused address pins become RFU.

Ball Descriptions

The ball descriptions table is a comprehensive list of all possible balls for all supported packages. Not all balls listed are supported for a given package.

Table 3: Ball Descriptions

Symbol	Type	Description
CK, CK#	Input	Clock: CK is the system clock input. CK and CK# are differential clock inputs. All address and control input signals are sampled on the crossing of the positive edge of CK and the negative edge of CK#. Input and output data is referenced to the crossing of CK and CK# (both directions of the crossing).
CKE CKE0, CKE1	Input	Clock enable: CKE HIGH activates, and CKE LOW deactivates, the internal clock signals, input buffers, and output drivers. Taking CKE LOW enables PRECHARGE power-down and SELF REFRESH operations (all banks idle), or ACTIVE power-down (row active in any bank). CKE is synchronous for all functions except SELF REFRESH exit. All input buffers (except CKE) are disabled during power-down and self refresh modes. CKE0 is used for a single LPDDR product. CKE1 is used for dual LPDDR products and is considered RFU for single LPDDR MCPs.
CS# CS0#, CS1#	Input	Chip select: CS# enables (registered LOW) and disables (registered HIGH) the command decoder. All commands are masked when CS# is registered HIGH. CS# provides for external bank selection on systems with multiple banks. CS# is considered part of the command code. CS0# is used for a single LPDDR product. CS1# is used for dual LPDDR products and is considered RFU for single LPDDR MCPs.
RAS#, CAS#, WE#	Input	Command inputs: RAS#, CAS#, and WE# (along with CS#) define the command being entered.
UDM, LDM (x16) DM[3:0] (x32)	Input	Input data mask: DM is an input mask signal for write data. Input data is masked when DM is sampled HIGH along with that input data during a WRITE access. DM is sampled on both edges of DQS. Although DM balls are input-only, the DM loading is designed to match that of DQ and DQS balls.
BA0, BA1	Input	Bank address inputs: BA0 and BA1 define to which bank an ACTIVE, READ, WRITE, or PRECHARGE command is being applied. BA0 and BA1 also determine which mode register is loaded during a LOAD MODE REGISTER command.
A[13:0]	Input	Address inputs: Provide the row address for ACTIVE commands, and the column address and auto precharge bit (A10) for READ or WRITE commands, to select one location out of the memory array in the respective bank. During a PRECHARGE command, A10 determines whether the PRECHARGE applies to one bank (A10 LOW, bank selected by BA0, BA1) or all banks (A10 HIGH). The address inputs also provide the op-code during a LOAD MODE REGISTER command. The maximum address range is dependent upon configuration. Unused address balls become RFU.
TEST	Input	Test pin: Must be tied to V _{SS} or V _{SSQ} in normal operations.
DQ[15:0] (x16) DQ[31:0] (x32)	Input/ output	Data input/output: Data bus for x16 and x32.
LDQS, UDQS (x16) DQS[3:0] (x32)	Input/ output	Data strobe: Output with read data, input with write data. DQS is edge-aligned with read data, center-aligned in write data. It is used to capture data.
TQ	Output	Temperature sensor output: TQ HIGH when LPDDR T _J exceeds 85°C.
V _{DDQ}	Supply	DQ power supply.

Table 3: Ball Descriptions (Continued)

Symbol	Type	Description
V _{SSQ}	Supply	DQ ground.
V _{DD}	Supply	Power supply.
V _{SS}	Supply	Ground.
NC	–	No connect: May be left unconnected.
RFU	–	Reserved for future use. Balls marked RFU may or may not be connected internally. These balls should not be used. Contact factory for details.

Package Dimensions

Figure 6: 60-Ball VFBGA (8mm x 9mm), Package code: BF

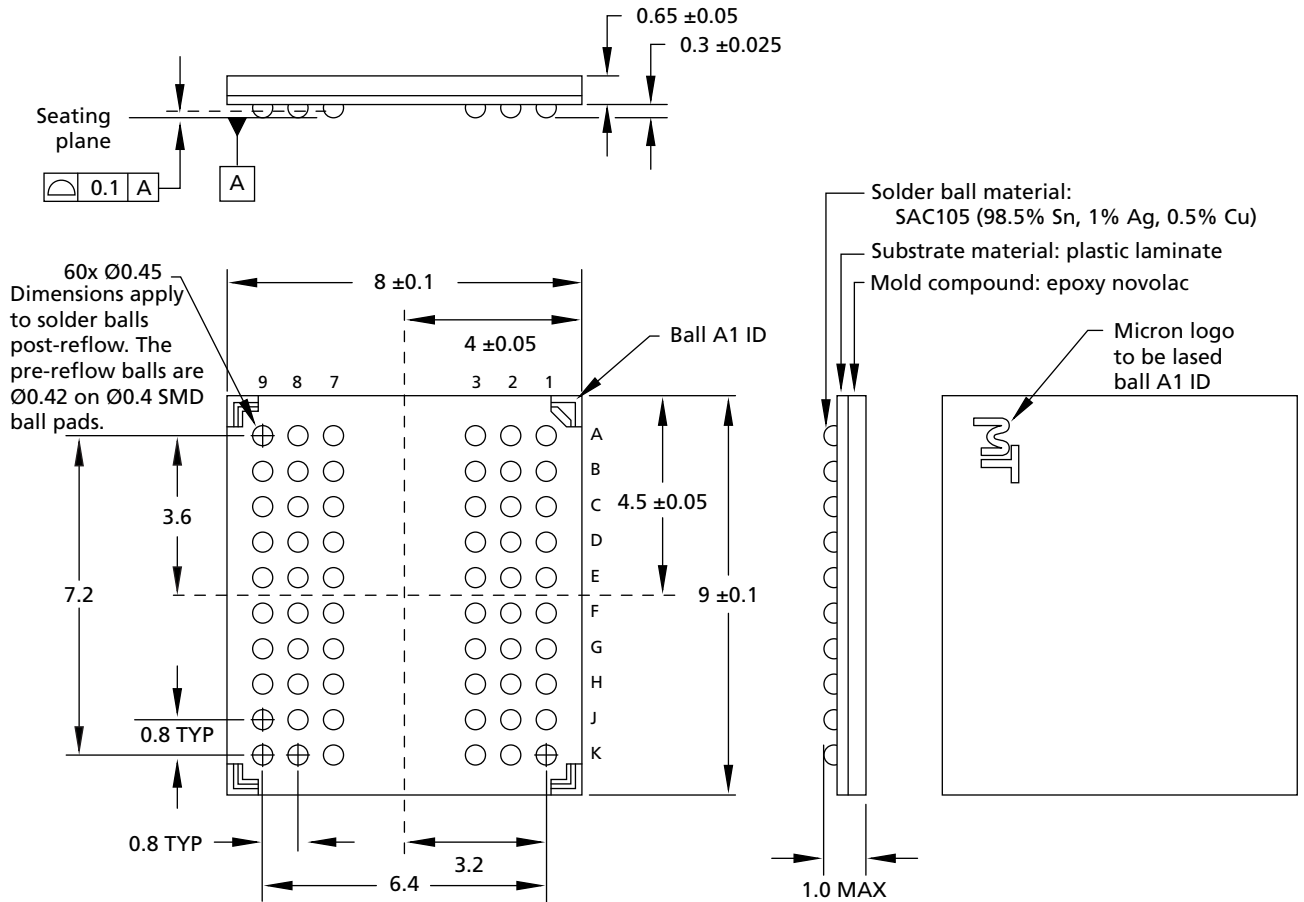

Note: 1. All dimensions are in millimeters.

Figure 7: 90-Ball VFBGA (8mm x 13mm), Package code: B5

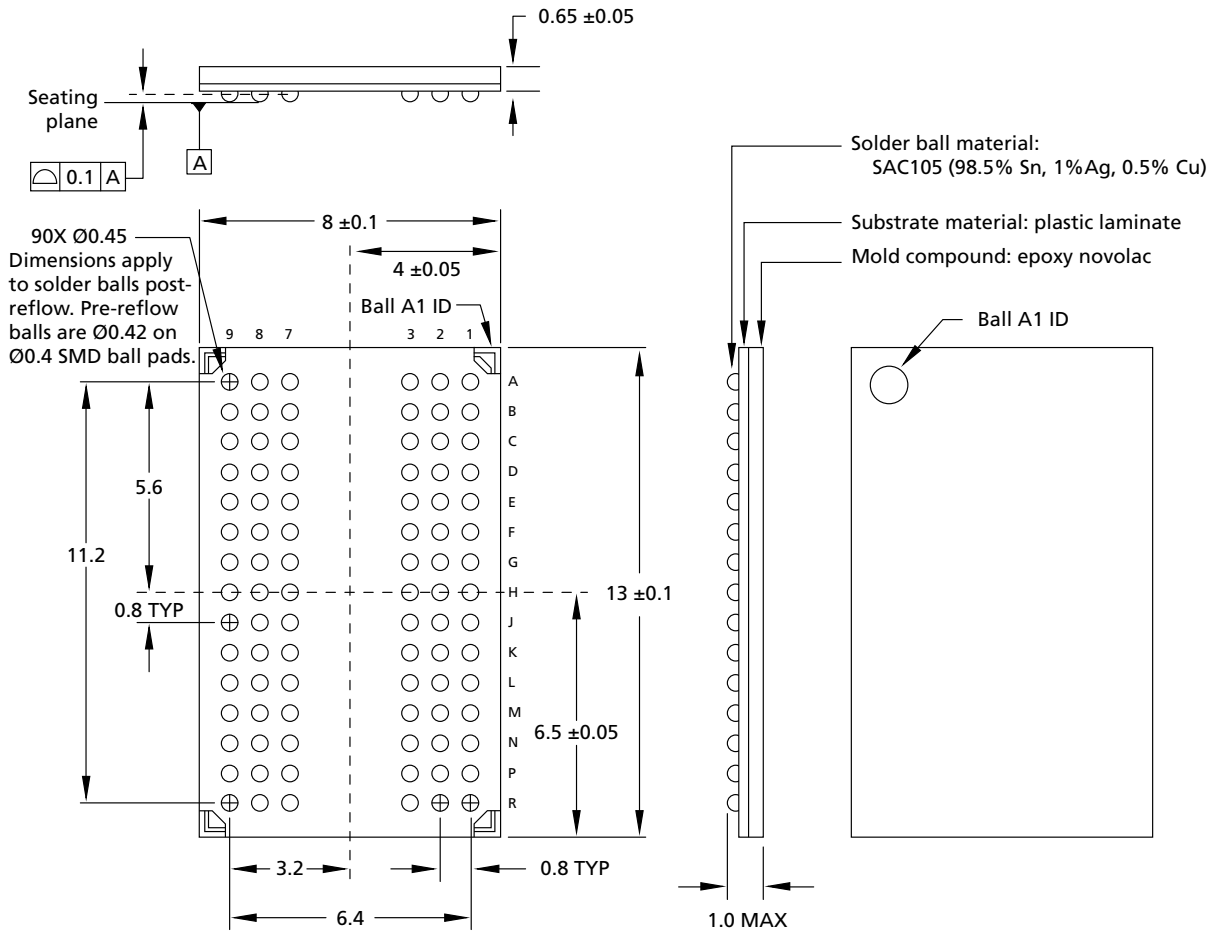

Note: 1. All dimensions are in millimeters.

Electrical Specifications

Stresses greater than those listed may cause permanent damage to the device. This is a stress rating only, and functional operation of the device at these or any other conditions above those indicated in the operational sections of this specification is not implied. Exposure to absolute maximum rating conditions for extended periods may affect reliability.

Table 4: Absolute Maximum Ratings

Note 1 applies to all parameters in this table

Parameter	Symbol	Min	Max	Unit
V_{DD}/V_{DDQ} supply voltage relative to V_{SS}	V_{DD}/V_{DDQ}	-1.0	+2.4	V
Voltage on any pin relative to V_{SS}	V_{IN}	-0.5	+2.4 or ($V_{DDQ} + 0.3V$), whichever is less	V
Storage temperature (plastic)	T_{STG}	-55	+150	°C

Note: 1. V_{DD} and V_{DDQ} must be within 300mV of each other at all times. V_{DDQ} must not exceed V_{DD} .

Table 5: AC/DC Electrical Characteristics and Operating Conditions

Notes 1–5 apply to all parameters/conditions in this table; $V_{DD}/V_{DDQ} = 1.70\text{--}1.95V$

Parameter/Condition	Symbol	Min	Max	Unit	Notes
Supply voltage	V_{DD}	1.70	1.95	V	6, 7
I/O supply voltage	V_{DDQ}	1.70	1.95	V	6, 7
Address and command inputs					
Input voltage high	V_{IH}	$0.8 \times V_{DDQ}$	$V_{DDQ} + 0.3$	V	8, 9
Input voltage low	V_{IL}	-0.3	$0.2 \times V_{DDQ}$	V	8, 9
Clock inputs (CK, CK#)					
DC input voltage	V_{IN}	-0.3	$V_{DDQ} + 0.3$	V	10
DC input differential voltage	$V_{ID(DC)}$	$0.4 \times V_{DDQ}$	$V_{DDQ} + 0.6$	V	10, 11
AC input differential voltage	$V_{ID(AC)}$	$0.6 \times V_{DDQ}$	$V_{DDQ} + 0.6$	V	10, 11
AC differential crossing voltage	V_{IX}	$0.4 \times V_{DDQ}$	$0.6 \times V_{DDQ}$	V	10, 12
Data inputs					
DC input high voltage	$V_{IH(DC)}$	$0.7 \times V_{DDQ}$	$V_{DDQ} + 0.3$	V	8, 9, 13
DC input low voltage	$V_{IL(DC)}$	-0.3	$0.3 \times V_{DDQ}$	V	8, 9, 13
AC input high voltage	$V_{IH(AC)}$	$0.8 \times V_{DDQ}$	$V_{DDQ} + 0.3$	V	8, 9, 13
AC input low voltage	$V_{IL(AC)}$	-0.3	$0.2 \times V_{DDQ}$	V	8, 9, 13
Data outputs					
DC output high voltage: Logic 1 ($I_{OH} = -0.1mA$)	V_{OH}	$0.9 \times V_{DDQ}$	-	V	
DC output low voltage: Logic 0 ($I_{OL} = 0.1mA$)	V_{OL}	-	$0.1 \times V_{DDQ}$	V	
Leakage current					
Input leakage current Any input $0V \leq V_{IN} \leq V_{DD}$ (All other pins not under test = 0V)	I_I	-1	+1	μA	

Table 5: AC/DC Electrical Characteristics and Operating Conditions (Continued)

Notes 1–5 apply to all parameters/conditions in this table; $V_{DD}/V_{DDQ} = 1.70\text{--}1.95V$

Parameter/Condition	Symbol	Min	Max	Unit	Notes
Output leakage current (DQ are disabled; $0V \leq V_{OUT} \leq V_{DDQ}$)	I_{OZ}	-5	+5	μA	
Operating temperature					
Commercial	T_A	0	+70	$^{\circ}C$	
Industrial	T_A	-40	+85	$^{\circ}C$	

- Notes:
- All voltages referenced to V_{SS} .
 - All parameters assume proper device initialization.
 - Tests for AC timing, I_{DD} , and electrical AC and DC characteristics may be conducted at nominal supply voltage levels, but the related specifications and device operation are guaranteed for the full voltage range specified.
 - Outputs measured with equivalent load; transmission line delay is assumed to be very small:

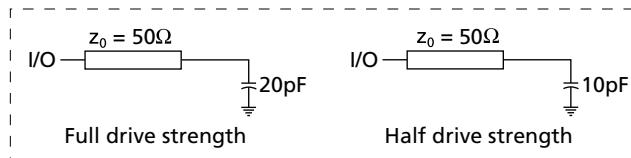

- Timing and I_{DD} tests may use a V_{IL} -to- V_{IH} swing of up to 1.5V in the test environment, but input timing is still referenced to $V_{DDQ/2}$ (or to the crossing point for CK/CK#). The output timing reference voltage level is $V_{DDQ/2}$.
- Any positive glitch must be less than one-third of the clock cycle and not more than +200mV or 2.0V, whichever is less. Any negative glitch must be less than one-third of the clock cycle and not exceed either -150mV or +1.6V, whichever is more positive.
- V_{DD} and V_{DDQ} must track each other and V_{DDQ} must be less than or equal to V_{DD} .
- To maintain a valid level, the transitioning edge of the input must:
 - Sustain a constant slew rate from the current AC level through to the target AC level, $V_{IL(AC)}$ Or $V_{IH(AC)}$.
 - Reach at least the target AC level.
 - After the AC target level is reached, continue to maintain at least the target DC level, $V_{IL(DC)}$ or $V_{IH(DC)}$.
- V_{IH} overshoot: $V_{IHmax} = V_{DDQ} + 1.0V$ for a pulse width $\leq 3ns$ and the pulse width cannot be greater than one-third of the cycle rate. V_{IL} undershoot: $V_{ILmin} = -1.0V$ for a pulse width $\leq 3ns$ and the pulse width cannot be greater than one-third of the cycle rate.
- CK and CK# input slew rate must be $\geq 1 V/ns$ (2 V/ns if measured differentially).
- V_{ID} is the magnitude of the difference between the input level on CK and the input level on CK#.
- The value of V_{IX} is expected to equal $V_{DDQ/2}$ of the transmitting device and must track variations in the DC level of the same.
- DQ and DM input slew rates must not deviate from DQS by more than 10%. 50ps must be added to t_{DS} and t_{DH} for each 100 mV/ns reduction in slew rate. If slew rate exceeds 4 V/ns, functionality is uncertain.

Table 6: Capacitance (x16, x32)

Note 1 applies to all the parameters in this table

Parameter	Symbol	Min	Max	Unit	Notes
Input capacitance: CK, CK#	C_{CK}	1.5	3.0	pF	
Delta input capacitance: CK, CK#	C_{DCK}	–	0.25	pF	2
Input capacitance: command and address	C_I	1.5	3.0	pF	
Delta input capacitance: command and address	C_{DI}	–	0.5	pF	2
Input/output capacitance: DQ, DQS, DM	C_{IO}	2.0	4.5	pF	
Delta input/output capacitance: DQ, DQS, DM	C_{DIO}	–	0.5	pF	3

- Notes:
1. This parameter is sampled. $V_{DD}/V_{DDQ} = 1.70\text{--}1.95V$, $f = 100\text{ MHz}$, $T_A = 25^\circ C$, $V_{OUT(DC)} = V_{DDQ}/2$, V_{OUT} (peak-to-peak) = 0.2V. DM input is grouped with I/O pins, reflecting the fact that they are matched in loading.
 2. The input capacitance per pin group will not differ by more than this maximum amount for any given device.
 3. The I/O capacitance per DQS and DQ byte/group will not differ by more than this maximum amount for any given device.

Electrical Specifications – I_{DD} Parameters

Table 7: I_{DD} Specifications and Conditions (x16)

 Notes 1–5 apply to all parameters/conditions in this table; V_{DD}/V_{DDQ} = 1.70–1.95V

Parameter/Condition	Symbol	Max				Unit	Notes	
		-5	-54	-6	-75			
Operating 1 bank active precharge current: $t_{RC} = t_{RC}(\text{MIN})$; $t_{CK} = t_{CK}(\text{MIN})$; CKE is HIGH; CS is HIGH between valid commands; Address inputs are switching every 2 clock cycles; Data bus inputs are stable	I _{DD0}	70	60	50	40	mA	6	
Precharge power-down standby current: All banks idle, CKE is LOW; CS is HIGH, $t_{CK} = t_{CK}(\text{MIN})$; Address and control inputs are switching; Data bus inputs are stable	I _{DD2P}	200	200	200	200	μA	7, 8	
Precharge power-down standby current: Clock stopped; All banks idle; CKE is LOW; CS is HIGH; CK = LOW, CK# = HIGH; Address and control inputs are switching; Data bus inputs are stable	I _{DD2PS}	200	200	200	200	μA	7	
Precharge nonpower-down standby current: All banks idle CKE = HIGH; CS = HIGH; $t_{CK} = t_{CK}(\text{MIN})$; Address and control inputs are switching; Data bus inputs are stable	I _{DD2N}	20	17	15	12	mA	9	
Precharge nonpower-down standby current: Clock stopped; All banks idle, CKE = HIGH; CS = HIGH; CK = LOW, CK# = HIGH; Address and control inputs are switching; Data bus inputs are stable	I _{DD2NS}	15	12	10	8	mA	9	
Active power-down standby current: 1 bank active, CKE = LOW; CS = HIGH; $t_{CK} = t_{CK}(\text{MIN})$; Address and control inputs are switching; Data bus inputs are stable	I _{DD3P}	3	3	3	3	mA	8	
Active power-down standby current: Clock stopped; 1 bank active, CKE = LOW; CS = HIGH; CK = LOW; CK# = HIGH; Address and control inputs are switching; Data bus inputs are stable	I _{DD3PS}	3	3	3	3	mA		
Active nonpower-down standby: 1 bank active, CKE = HIGH; CS = HIGH; $t_{CK} = t_{CK}(\text{MIN})$; Address and control inputs are switching; Data bus inputs are stable	I _{DD3N}	25	22	20	15	mA	6	
Active nonpower-down standby: Clock stopped; 1 bank active, CKE = HIGH; CS = HIGH; CK = LOW; CK# = HIGH; Address and control inputs are switching; Data bus inputs are stable	I _{DD3NS}	20	17	15	10	mA	6	
Operating burst read: 1 bank active; BL = 4; $t_{CK} = t_{CK}(\text{MIN})$; Continuous READ bursts; I _{OUT} = 0mA; Address inputs are switching every 2 clock cycles; 50% data changing each burst	I _{DD4R}	90	85	80	70	mA	6	
Operating burst write: 1 bank active; BL = 4; $t_{CK} = t_{CK}(\text{MIN})$; Continuous WRITE bursts; Address inputs are switching; 50% data changing each burst	I _{DD4W}	90	85	80	70	mA	6	
Auto refresh: Burst refresh; CKE = HIGH; Address and control inputs are switching; Data bus inputs are stable	$t_{RFC} = 110\text{ns}$	I _{DD5}	95	92	90	85	mA	10
	$t_{RFC} = t_{REFI}$	I _{DD5A}	8	6	5	3	mA	10, 11
Deep power-down current: Address and control balls are stable; Data bus inputs are stable	I _{DD8}	10	10	10	10	μA	7, 13	

Table 8: I_{DD} Specifications and Conditions (x32)

 Notes 1–5 apply to all parameters/conditions in this table; V_{DD}/V_{DDQ} = 1.70–1.95V

Parameter/Condition	Symbol	Max				Unit	Notes	
		-5	-54	-6	-75			
Operating 1 bank active precharge current: $t_{RC} = t_{RC}(\text{MIN})$; $t_{CK} = t_{CK}(\text{MIN})$; CKE is HIGH; CS is HIGH between valid commands; Address inputs are switching every 2 clock cycles; Data bus inputs are stable	I _{DD0}	70	60	50	40	mA	6	
Precharge power-down standby current: All banks idle; CKE is LOW; CS is HIGH; $t_{CK} = t_{CK}(\text{MIN})$; Address and control inputs are switching; Data bus inputs are stable	I _{DD2P}	200	200	200	200	μA	7, 8	
Precharge power-down standby current: Clock stopped; All banks idle; CKE is LOW; CS is HIGH, CK = LOW, CK# = HIGH; Address and control inputs are switching; Data bus inputs are stable	I _{DD2PS}	200	200	200	200	μA	7	
Precharge nonpower-down standby current: All banks idle CKE = HIGH; CS = HIGH; $t_{CK} = t_{CK}(\text{MIN})$; Address and control inputs are switching; Data bus inputs are stable	I _{DD2N}	20	17	15	12	mA	9	
Precharge nonpower-down standby current: Clock stopped; All banks idle, CKE = HIGH; CS = HIGH; CK = LOW, CK# = HIGH; Address and control inputs are switching; Data bus inputs are stable	I _{DD2NS}	15	12	10	8	mA	9	
Active power-down standby current: 1 bank active, CKE = LOW; CS = HIGH; $t_{CK} = t_{CK}(\text{MIN})$; Address and control inputs are switching; Data bus inputs are stable	I _{DD3P}	3	3	3	3	mA	8	
Active power-down standby current: Clock stopped; 1 bank active, CKE = LOW; CS = HIGH; CK = LOW; CK# = HIGH; Address and control inputs are switching; Data bus inputs are stable	I _{DD3PS}	3	3	3	3	mA		
Active nonpower-down standby: 1 bank active; CKE = HIGH; CS = HIGH; $t_{CK} = t_{CK}(\text{MIN})$; Address and control inputs are switching; Data bus inputs are stable	I _{DD3N}	25	22	20	15	mA	6	
Active nonpower-down standby: Clock stopped; 1 bank active, CKE = HIGH; CS = HIGH; CK = LOW; CK# = HIGH; Address and control inputs are switching; Data bus inputs are stable	I _{DD3NS}	20	17	15	10	mA	6	
Operating burst read: 1 bank active; BL = 4; CL = 3; $t_{CK} = t_{CK}(\text{MIN})$; Continuous READ bursts; I _{OUT} = 0mA; Address inputs are switching every 2 clock cycles; 50% data changing each burst	I _{DD4R}	110	105	100	90	mA	6	
Operating burst write: One bank active; BL = 4; $t_{CK} = t_{CK}(\text{MIN})$; Continuous WRITE bursts; Address inputs are switching; 50% data changing each burst	I _{DD4W}	110	105	100	90	mA	6	
Auto refresh: Burst refresh; CKE = HIGH; Address and control inputs are switching; Data bus inputs are stable	$t_{RFC} = 110\text{ns}$	I _{DD5}	95	92	90	85	mA	10
	$t_{RFC} = t_{REFI}$	I _{DD5A}	8	6	5	3	mA	10, 11
Deep power-down current: Address and control pins are stable; Data bus inputs are stable	I _{DD8}	10	10	10	10	μA	7, 13	

Table 9: I_{DD6} Specifications and Conditions

Notes 1–5, 7, and 12 apply to all parameters/conditions in this table; V_{DD}/V_{DDQ}= 1.70–1.95V

Parameter/Condition		Symbol	I _{DD6}	Units
Self refresh CKE = LOW; t ^{CK} = t ^{CK} (MIN); Address and control inputs are stable; Data bus inputs are stable	Full array, 85°C	I _{DD6A}	200	μA
	Full array, 45°C	I _{DD6C}	140	μA
	1/2 array, 85°C	I _{DD6A}	160	μA
	1/2 array, 45°C	I _{DD6C}	120	μA
	1/4 array, 85°C	I _{DD6A}	140	μA
	1/4 array, 45°C	I _{DD6C}	100	μA
	1/8 array, 85°C	I _{DD6A}	120	μA
	1/8 array, 45°C	I _{DD6C}	95	μA
	1/16 array, 85°C	I _{DD6A}	100	μA
	1/16 array, 45°C	I _{DD6C}	90	μA

- Notes:
- All voltages referenced to V_{SS}.
 - Tests for I_{DD} characteristics may be conducted at nominal supply voltage levels, but the related specifications and device operation are guaranteed for the full voltage range specified.
 - Timing and I_{DD} tests may use a V_{IL}-to-V_{IH} swing of up to 1.5V in the test environment, but input timing is still referenced to V_{DDQ}/2 (or to the crossing point for CK/CK#). The output timing reference voltage level is V_{DDQ}/2.
 - I_{DD} is dependent on output loading and cycle rates. Specified values are obtained with minimum cycle time with the outputs open.
 - I_{DD} specifications are tested after the device is properly initialized and values are averaged at the defined cycle rate.
 - MIN (t^{RC} or t^{RFC}) for I_{DD} measurements is the smallest multiple of t^{CK} that meets the minimum absolute value for the respective parameter. t^{RAS} (MAX) for I_{DD} measurements is the largest multiple of t^{CK} that meets the maximum absolute value for t^{RAS}.
 - Measurement is taken 500ms after entering into this operating mode to allow settling time for the tester.
 - V_{DD} must not vary more than 4% if CKE is not active while any bank is active.
 - I_{DD2N} specifies DQ, DQS, and DM to be driven to a valid high or low logic level.
 - CKE must be active (HIGH) during the entire time a REFRESH command is executed. From the time the AUTO REFRESH command is registered, CKE must be active at each rising clock edge until t^{RFC} later.
 - This limit is a nominal value and does not result in a fail. CKE is HIGH during REFRESH command period (t^{RFC} [MIN]) else CKE is LOW (for example, during standby).
 - Values for I_{DD6} 85°C are guaranteed for the entire temperature range. All other I_{DD6} values are estimated.
 - Typical values at 25°C, not a maximum value.

Figure 8: Typical Self Refresh Current vs. Temperature

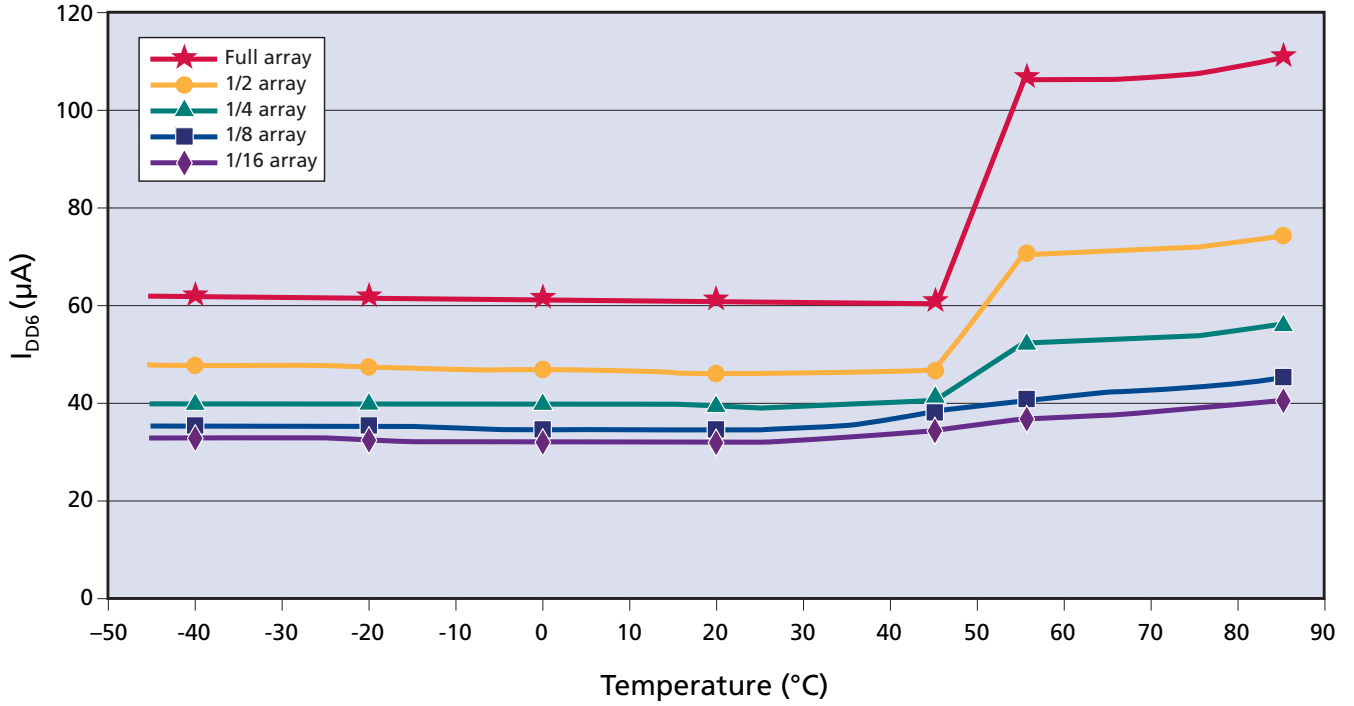



Electrical Specifications – AC Operating Conditions

Table 10: Electrical Characteristics and Recommended AC Operating Conditions

Notes 1–9 apply to all the parameters in this table; $V_{DD}/V_{DDQ} = 1.70\text{--}1.95V$

Parameter	Symbol	-5		-54		-6		-75		Unit	Notes	
		Min	Max	Min	Max	Min	Max	Min	Max			
Access window of DQ from CK/CK#	CL = 3	t_{AC}	2.0	5.0	2.0	5.0	2.0	5.0	2.0	6.0	ns	
	CL = 2		2.0	6.5	2.0	6.5	2.0	6.5	2.0	6.5		
Clock cycle time	CL = 3	t_{CK}	5.0	–	5.4	–	6	–	7.5	–	ns	10
	CL = 2		12	–	12	–	12	–	12	–		
CK high-level width		t_{CH}	0.45	0.55	0.45	0.55	0.45	0.55	0.45	0.55	t_{CK}	
CK low-level width		t_{CL}	0.45	0.55	0.45	0.55	0.45	0.55	0.45	0.55	t_{CK}	
CKE minimum pulse width (high and low)		t_{CKE}	1	–	1	–	1	–	1	–	t_{CK}	11
Auto precharge write recovery + precharge time		t_{DAL}	–	–	–	–	–	–	–	–	–	12
DQ and DM input hold time relative to DQS (fast slew rate)		t_{DH_f}	0.48	–	0.54	–	0.6	–	0.8	–	ns	13, 14, 15
DQ and DM input hold time relative to DQS (slow slew rate)		t_{DH_s}	0.58	–	0.64	–	0.7	–	0.9	–	ns	
DQ and DM input setup time relative to DQS (fast slew rate)		t_{DS_f}	0.48	–	0.54	–	0.6	–	0.8	–	ns	13, 14, 15
DQ and DM input setup time relative to DQS (slow slew rate)		t_{DS_s}	0.58	–	0.64	–	0.7	–	0.9	–	ns	
DQ and DM input pulse width (for each input)		t_{DIPW}	1.8	–	1.9	–	2.1	–	1.8	–	ns	16
Access window of DQS from CK/CK#	CL = 3	t_{DQSK}	2.0	5.0	2.0	5.0	2.0	5.0	2.0	6.0	ns	
	CL = 2		2.0	6.5	2.0	6.5	2.0	6.5	2.0	6.5	ns	
DQS input high pulse width		t_{DQSH}	0.4	0.6	0.4	0.6	0.4	0.6	0.4	0.6	t_{CK}	
DQS input low pulse width		t_{DQSL}	0.4	0.6	0.4	0.6	0.4	0.6	0.4	0.6	t_{CK}	
DQS–DQ skew, DQS to last DQ valid, per group, per access		t_{DQSQ}	–	0.4	–	0.45	–	0.5	–	0.6	ns	13, 17
WRITE command to first DQS latching transition		t_{DQSS}	0.75	1.25	0.75	1.25	0.75	1.25	0.75	1.25	t_{CK}	
DQS falling edge from CK rising – hold time		t_{DSH}	0.2	–	0.2	–	0.2	–	0.2	–	t_{CK}	
DQS falling edge to CK rising – setup time		t_{DSS}	0.2	–	0.2	–	0.2	–	0.2	–	t_{CK}	



128Mb: x16, x32 Mobile LPDDR SDRAM Electrical Specifications – AC Operating Conditions

Table 10: Electrical Characteristics and Recommended AC Operating Conditions (Continued)

Notes 1–9 apply to all the parameters in this table; $V_{DD}/V_{DDQ} = 1.70\text{--}1.95V$

Parameter	Symbol	-5		-54		-6		-75		Unit	Notes	
		Min	Max	Min	Max	Min	Max	Min	Max			
Data valid output window (DVW)	n/a	$t_{QH} - t_{DQSQ}$		$t_{QH} - t_{DQSQ}$		$t_{QH} - t_{DQSQ}$		$t_{QH} - t_{DQSQ}$		ns	17	
Half-clock period	t_{HP}	t_{CH} , t_{CL}	–	t_{CH} , t_{CL}	–	t_{CH} , t_{CL}	–	t_{CH} , t_{CL}	–	ns	18	
Data-out High-Z window from CK/CK#	CL = 3	t_{HZ}	–	5.0	–	5.0	–	5.0	–	6.0	ns	19, 20
	CL = 2	t_{HZ}	–	6.5	–	6.5	–	6.5	–	6.5	ns	
Data-out Low-Z window from CK/CK#	t_{LZ}	1.0	–	1.0	–	1.0	–	1.0	–	ns	19	
Address and control input hold time (fast slew rate)	t_{IH_F}	0.9	–	1.0	–	1.1	–	1.3	–	ns	15, 21	
Address and control input hold time (slow slew rate)	t_{IH_S}	1.1	–	1.2	–	1.3	–	1.5	–	ns		
Address and control input setup time (fast slew rate)	t_{IS_F}	0.9	–	1.0	–	1.1	–	1.3	–	ns	15, 21	
Address and control input setup time (slow slew rate)	t_{IS_S}	1.1	–	1.2	–	1.3	–	1.5	–	ns		
Address and control input pulse width	t_{IPW}	2.3	–	2.5	–	$t_{IS} + t_{IH}$	–	$t_{IS} + t_{IH}$	–	ns	16	
LOAD MODE REGISTER command cycle time	t_{MRD}	2	–	2	–	2	–	2	–	t_{CK}		
DQ–DQS hold, DQS to first DQ to go nonvalid, per access	t_{QH}	$t_{HP} - t_{QHS}$	–	$t_{HP} - t_{QHS}$	–	$t_{HP} - t_{QHS}$	–	$t_{HP} - t_{QHS}$	–	ns	13, 17	
Data hold skew factor	t_{QHS}	–	0.5	–	0.5	–	0.65	–	0.75	ns		
ACTIVE-to-PRECHARGE command	t_{RAS}	40	70,000	42	70,000	42	70,000	45	70,000	ns	22	
ACTIVE to ACTIVE/ACTIVE to AUTO REFRESH command period	t_{RC}	55	–	58.2	–	60	–	67.5	–	ns	23	
Active to read or write delay	t_{RCD}	15	–	16.2	–	18	–	22.5	–	ns		
Refresh period	t_{REF}	–	64	–	64	–	64	–	64	ms		
Average periodic refresh interval: 64Mb, 128Mb, and 256Mb (x32)	t_{REFI}	–	15.6	–	15.6	–	15.6	–	15.6	μs		
Average periodic refresh interval: 256Mb, 512Mb, 1Gb, 2Gb	t_{REFI}	–	7.8	–	7.8	–	7.8	–	7.8	μs		