

## DESCRIPTION

MT7755 is a high current precision TRIAC dimmable LED driver. It's mainly applied for non-isolated LED power systems. MT7755 supports high power factor application. Power Factor (PF) can reach 0.9 or higher.

MT7755 is based on BOOST topology. It integrates proprietary linear compensation circuit, to achieve excellent constant current performance and wide range dimmer compatibility.

MT7755 integrates high voltage supply circuit, which saves the VCC capacitor and start-up resistor. It also integrates a 600V MOSFET, which greatly reduces BOM cost and peripheral components.

Critical conduction mode ensures that the MT7755 turns the internal MOSFET on, when the inductor current reaches zero, reducing the power MOSFET switching loss, and achieving more than 90% efficiency. And the system is insensitive to the inductance changes.

MT7755 provides various protections, such as over current protection (OCP), short circuit protection (SCP), over voltage protection (OVP), etc., to ensure system reliability.

Meanwhile, the particular over temperature regulation (OTR) module is designed to reduce output current at high temperature with a high precision regulation range at  $\pm 5^{\circ}\text{C}$ .

## APPLICATIONS

- LED bulb, LED tube, LED signal and landscape lamp
- General purpose constant current source

## FEATURES

- No VCC capacitor and start-up resistor
- Supports high PF application, which reaches 0.9 or higher.
- Wide range of dimmer compatibility
- Up to 90% high efficiency
- Dimming curve is compliant with NEMA SSL6
- Embedded with 600V power MOSFET
- Highly accurate constant LED current
- Cycle-by-cycle peak current control
- Leading edge blanking technique
- Supports various protections,
  - LED short circuit protection
  - LED over voltage protection
  - Over temperature regulation
  - Under-voltage lockout protection
- Available in SOP8 package

## Typical Application Circuit

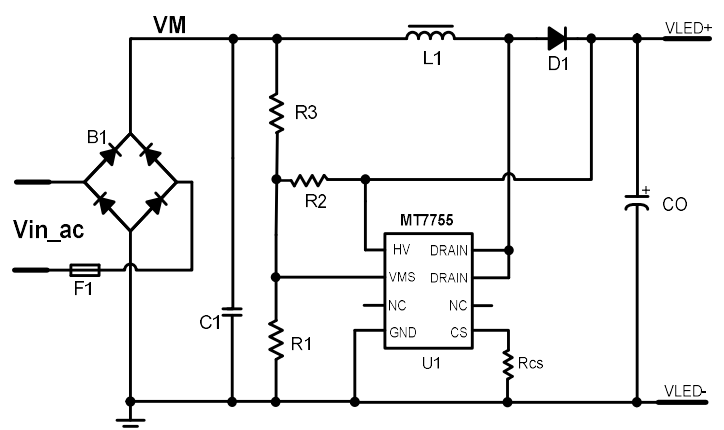

**Fig.1 Boost Application Circuit**