



Chipsmall Limited consists of a professional team with an average of over 10 year of expertise in the distribution of electronic components. Based in Hongkong, we have already established firm and mutual-benefit business relationships with customers from,Europe,America and south Asia,supplying obsolete and hard-to-find components to meet their specific needs.

With the principle of “Quality Parts,Customers Priority,Honest Operation,and Considerate Service”,our business mainly focus on the distribution of electronic components. Line cards we deal with include Microchip,ALPS,ROHM,Xilinx,Pulse,ON,Everlight and Freescale. Main products comprise IC,Modules,Potentiometer,IC Socket,Relay,Connector.Our parts cover such applications as commercial,industrial, and automotives areas.

We are looking forward to setting up business relationship with you and hope to provide you with the best service and solution. Let us make a better world for our industry!



Contact us

Tel: +86-755-8981 8866 Fax: +86-755-8427 6832

Email & Skype: info@chipsmall.com Web: www.chipsmall.com

Address: A1208, Overseas Decoration Building, #122 Zhenhua RD., Futian, Shenzhen, China



DDR SDRAM Unbuffered DIMM

MT8VDDT3232U – 128MB

MT8VDDT6432U – 256MB

MT8VDDT12832U – 512MB

For DDR SDRAM component specifications, please refer to the Micron® Web site: www.micron.com/

Features

- 100-pin, dual in-line memory module (DIMM)
- Fast data transfer rate: PC2100 and PC2700
- Utilizes 266 MT/s or 333 MT/s DDR SDRAM components
- 128MB (16 Meg x 32), 256MB (32 Meg x 32), 512MB (64 Meg x 32)
- VDD = +2.5V
- 2.5V I/O (SSTL_2 compatible)
- Commands entered on each positive CK edge
- DQS edge-aligned with data for READs; center-aligned with data for WRITEs
- Internal, pipelined double data rate (DDR) architecture; two data accesses per clock cycle
- Bidirectional data strobe (DQS) transmitted/received with data—*i.e.*, source-synchronous data capture
- Differential clock inputs CK and CK#
- Four internal device banks for concurrent operation
- Programmable burst lengths: 2, 4, or 8
- Auto precharge option
- Serial Presence Detect (SPD) with EEPROM
- Programmable READ CAS latency
- Auto Refresh and Self Refresh Modes
- 15.625µs (128MB), 7.8125µs (256MB, 512MB) maximum average periodic refresh interval
- Gold edge contacts
- Dual rank

Figure 1: 100-Pin DIMM (MO-161)

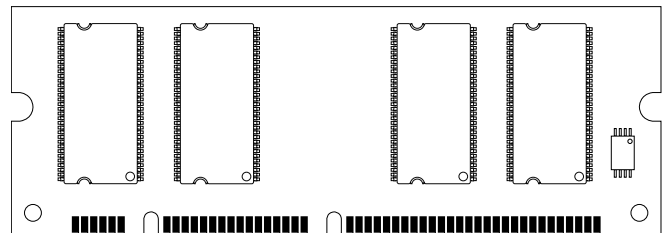

Options

- Package
 - 100-pin DIMM (standard)
 - 100-pin DIMM (lead-free)¹
- Operating Temperature Range
 - Commercial (ambient)
 - Industrial (ambient)
- Frequency/CAS Latency²
 - 6ns/167 MHz (333MT/s) CL = 2.5
 - 7.5ns/133 MHz (266 MT/s) CL = 2
 - 7.5ns/133 MHz (266 MT/s) CL = 2.5

Marking

G
Y
None
I
-6
-75Z ¹
-75

Notes: 1. Contact Micron for product availability.
2. CL = CAS (READ) latency.



128MB, 256MB, 512MB: (x32, DR) 100-Pin DDR UDIMM Features

Table 1: Address Table

	MT8VDDT3232U	MT8VDDT6432U	MT8VDDT12832U
Refresh Count	4K	8K	8K
Row Addressing	4K (A0–A11)	8K (A0–A12)	8K (A0–A12)
Device Bank Addressing	4 (BA0, BA1)	4 (BA0, BA1)	4 (BA0, BA1)
Device Configuration	128Mb (16 Meg x 8)	256Mb (32 Meg x 8)	512Mb (64 Meg x 8)
Column Addressing	1K (A0–A9)	1K (A0–A9)	1K (A0–A9, A11)
Module Rank Addressing	2 (S0#, S1#)	2 (S0#, S1#)	2 (S0#, S1#)

Table 2: Part Numbers and Timing Parameters

Part Number	Module Density	Configuration	Module Bandwidth	Memory Clock/ Data Bit Rate	Latency (CL - ^t RCD - ^t RP)
MT8VDDT3232UG-6__	128MB	16 Meg x 32	2.7 GB/s	6ns/333 MT/s	2.5-3-3
MT8VDDT3232UY-6__	128MB	16 Meg x 32	2.7 GB/s	6ns/333 MT/s	2.5-3-3
MT8VDDT3232UG-75Z__	128MB	16 Meg x 32	2.1 GB/s	7.5ns/266 MT/s	2-3-3
MT8VDDT3232UY-75Z__	128MB	16 Meg x 32	2.1 GB/s	7.5ns/266 MT/s	2-3-3
MT8VDDT3232UG-75__	128MB	16 Meg x 32	2.1 GB/s	7.5ns/266 MT/s	2.5-3-3
MT8VDDT3232UY-75__	128MB	16 Meg x 32	2.1 GB/s	7.5ns/266 MT/s	2.5-3-3
MT8VDDT6432UG-6__	256MB	32 Meg x 32	2.7 GB/s	6ns/333 MT/s	2.5-3-3
MT8VDDT6432UY-6__	256MB	32 Meg x 32	2.7 GB/s	6ns/333 MT/s	2.5-3-3
MT8VDDT6432UG-75Z__	256MB	32 Meg x 32	2.1 GB/s	7.5ns/266 MT/s	2-3-3
MT8VDDT6432UY-75Z__	256MB	32 Meg x 32	2.1 GB/s	7.5ns/266 MT/s	2-3-3
MT8VDDT6432UG-75__	256MB	32 Meg x 32	2.1 GB/s	7.5ns/266 MT/s	2.5-3-3
MT8VDDT6432UY-75__	256MB	32 Meg x 32	2.1 GB/s	7.5ns/266 MT/s	2.5-3-3
MT8VDDT12832UG-6__	512MB	64 Meg x 32	2.7 GB/s	6ns/333 MT/s	2.5-3-3
MT8VDDT12832UY-6__	512MB	64 Meg x 32	2.7 GB/s	6ns/333 MT/s	2.5-3-3
MT8VDDT12832UG-75Z__	512MB	64 Meg x 32	2.1 GB/s	7.5ns/266 MT/s	2-3-3
MT8VDDT12832UY-75Z__	512MB	64 Meg x 32	2.1 GB/s	7.5ns/266 MT/s	2-3-3
MT8VDDT12832UG-75__	512MB	64 Meg x 32	2.1 GB/s	7.5ns/266 MT/s	2.5-3-3
MT8VDDT12832UY-75__	512MB	64 Meg x 32	2.1 GB/s	7.5ns/266 MT/s	2.5-3-3

All part numbers end with a two-place code (not shown), designating component and PCB revisions. Consult factory for current revision codes. Example: MT8VDDT3232UG-75B1.



Table of Contents

Features	1
Table of Contents	3
List of Figures	4
List of Tables	5
Pin Assignments and Descriptions	6
Functional Block	9
General Description	10
Serial Presence-Detect Operation	10
Mode Register Definition	11
Burst Length	11
Burst Type	11
Read Latency	11
Operating Mode	14
Extended Mode Register	14
DLL Enable/Disable	15
Commands	16
Parameter Tables	17
Absolute Maximum Ratings	17
Notes	23
Initialization	28
Serial Presence Detect	30
SPD Clock and Data Conventions	30
SPD Start Condition	30
SPD Stop Condition	30
SPD Acknowledge	30
Module Dimensions	36
Data Sheet Designation	36

List of Figures

Figure 1:	100-Pin DIMM (MO-161)	1
Figure 2:	Module Layout	6
Figure 3:	Functional Block Diagram	9
Figure 4:	Mode Register Definition Diagram	12
Figure 5:	CAS Latency Diagram	14
Figure 6:	Extended Mode Register Definition Diagram	15
Figure 7:	Derating Data Valid Window $t_{QH} - t_{(DQSQ)}$	25
Figure 8:	Pull-Down Characteristics	26
Figure 9:	Pull-Up Characteristics	27
Figure 10:	Initialization Flow Diagram	29
Figure 11:	Data Validity	30
Figure 12:	Definition of Start and Stop	31
Figure 13:	Acknowledge Response From Receiver	31
Figure 14:	SPD EEPROM Timing Diagram	32
Figure 15:	100-Pin DIMM Dimensions	36



List of Tables

Table 1:	Address Table	2
Table 2:	Part Numbers and Timing Parameters	2
Table 3:	Pin Assignment	6
Table 4:	Pin Descriptions	7
Table 5:	Burst Definition Table	13
Table 6:	CAS Latency (CL) Table	13
Table 7:	Commands Truth Table	16
Table 8:	DM Operation Truth Table	16
Table 9:	DC Electrical Characteristics and Operating Conditions	17
Table 10:	AC Input Operating Conditions	17
Table 11:	IDD Specifications and Conditions – 128MB	18
Table 12:	IDD Specifications and Conditions – 256MB	19
Table 13:	IDD Specifications and Conditions – 512MB	20
Table 14:	Capacitance (All Modules)	21
Table 15:	Component Electrical Characteristics and Recommended AC Operating Conditions	21
Table 16:	EEPROM Device Select Code	32
Table 17:	EEPROM Operating Modes	32
Table 18:	Serial Presence-Detect EEPROM DC Operating Conditions	33
Table 19:	Serial Presence-Detect EEPROM AC Operating Conditions	33
Table 20:	Serial Presence-Detect Matrix	34

Pin Assignments and Descriptions

Table 3: Pin Assignment

100-Pin DIMM Front								100-Pin DIMM Back							
Pin	Symbol	Pin	Symbol	Pin	Symbol	Pin	Symbol	Pin	Symbol	Pin	Symbol	Pin	Symbol	Pin	Symbol
1	DQ0	14	V _{DD}	26	A5	39	DQ18	51	DQ4	64	V _{DD}	76	A2	89	DQ22
2	V _{SS}	15	DQ11	27	A3	40	DQ19	52	V _{SS}	65	DQ15	77	A0	90	DQ23
3	DQ1	16	V _{SS}	28	A1	41	V _{DD}	53	DQ5	66	V _{SS}	78	BA1	91	V _{DD}
4	DQS0	17	CK0	29	A10	42	DQ24	54	DM0	67	CK1	79	RAS#	92	DQ28
5	V _{DD}	18	CK0#	30	V _{DD}	43	DQ25	55	V _{DD}	68	CK1#	80	V _{DD}	93	DQ29
6	DQ2	19	V _{DD}	31	BA0	44	V _{SS}	56	DQ6	69	V _{DD}	81	CAS#	94	V _{SS}
7	DQ3	20	CKE1	32	WE#	45	DQS3	57	DQ7	70	CKE0	82	S1#	95	DM3
8	V _{DD}	21	NC/A12	33	S0#	46	DQ26	58	V _{DD}	71	A11	83	DNU	96	DQ30
9	DQ8	22	NC	34	DQ16	47	V _{SS}	59	DQ12	72	A8	84	DQ20	97	V _{SS}
10	DQ9	23	A9	35	V _{SS}	48	DQ27	60	DQ13	73	A6	85	V _{SS}	98	DQ31
11	V _{SS}	24	A7	36	DQ17	49	SA0	61	V _{SS}	74	A4	86	DQ21	99	SDA
12	DQS1	25	V _{SS}	37	DQS2	50	VREF	62	DM1	75	V _{SS}	87	DM2	100	SCL
13	DQ10			38	V _{DD}			63	DQ14			88	V _{DD}		

Note: Pin 21 is No Connect for the 128MB module, or A12 for the 256MB or 512MB modules.

Figure 2: Module Layout

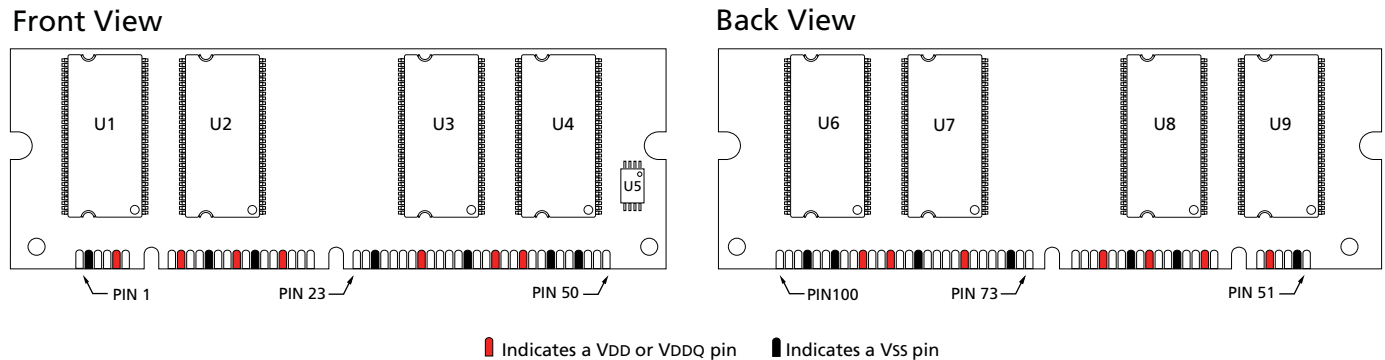

Table 4: Pin Descriptions

Pin numbers may not correlate with symbols; refer to Figure 3 on page 6 for more information

Pin Numbers	Symbol	Type	Description
32, 79, 81	WE#, CAS#, RAS#	Input	Command Inputs: RAS#, CAS#, and WE# (along with S#) define the command being entered.
17, 18, 67, 68	CK0, CK0#, CK1, CK1#	Input	Clock: CK, CK# are differential clock inputs. All address and control input signals are sampled on the crossing of the positive edge of CK, and negative edge of CK#. Output data (DQ and DQS) is referenced to the crossings of CK and CK#.
20, 70	CKE0, CKE1	Input	Clock Enable: CKE HIGH activates and CKE LOW deactivates the internal clock, input buffers and output drivers. Taking CKE LOW provides PRECHARGE POWER-DOWN and SELF REFRESH operations (all device banks idle), or ACTIVE POWER-DOWN (row ACTIVE in any device bank). CKE is synchronous for POWER-DOWN entry and exit, and for SELF REFRESH entry. CKE is asynchronous for SELF REFRESH exit and for disabling the outputs. CKE must be maintained HIGH throughout read and write accesses. Input buffers (excluding CK, CK#, and CKE) are disabled during POWER-DOWN. Input buffers (excluding CKE) are disabled during SELF REFRESH. CKE is an SSTL_2 input but will detect an LVCMOS LOW level after VDD is applied and until CKE is first brought HIGH. After CKE is brought HIGH, it becomes an SSTL_2 input only.
33, 82	S0#, S1#	Input	Chip Selects: S# enables (registered LOW) and disables (registered HIGH) the command decoder. All commands are masked when S# is registered HIGH. S# is considered part of the command code.
31, 78	BA0, BA1	Input	Bank Address: BA0 and BA1 define to which device bank an ACTIVE, READ, WRITE, or PRECHARGE command is being applied.
21 (256MB, 512MB), 23, 24, 26-29, 71-74, 76, 77	A0-A11 (128MB) A0-A12 (256MB, 512MB)	Input	Address Inputs: Provide the row address for ACTIVE commands, and the column address and auto precharge bit (A10) for READ/WRITE commands, to select one location out of the memory array in the respective device bank. A10 sampled during a PRECHARGE command determines whether the PRECHARGE applies to one device bank (A10 LOW, device bank selected by BA0, BA1) or all device banks (A10 HIGH). The address inputs also provide the op-code during a MODE REGISTER SET command. BA0 and BA1 define which mode register (mode register or extended mode register) is loaded during the LOAD MODE REGISTER command.
4, 12, 37, 45	DQS0-DQS3	Input/Output	Data Strobe: Output with READ data, input with WRITE data. DQS is edge-aligned with READ data, centered in WRITE data. Used to capture data.
54, 62, 87, 95	DM0-DM3	Input	Data Write Mask. DM LOW allows WRITE operation. DM HIGH blocks WRITE operation. DM lines do not affect READ operation.
1, 3, 6, 7, 9, 10, 13, 15, 34, 36, 39, 40, 42, 43, 46, 48, 51, 53, 56, 57, 59, 60, 63, 65, 84, 86, 89, 90, 92, 93, 96, 98	DQ0-DQ31	Input/Output	Data I/Os: Data bus.
49	SA0	Input	Presence-Detect Address Inputs: These pins are used to configure the presence-detect device.

Table 4: Pin Descriptions (Continued)

Pin numbers may not correlate with symbols; refer to Figure 3 on page 6 for more information

Pin Numbers	Symbol	Type	Description
99	SDA	Input/ Output	Serial Presence-Detect Data: SDA is a bidirectional pin used to transfer addresses and data into and out of the presence-detect portion of the module.
100	SCL	Input	Serial Clock for Presence-Detect: SCL is used to synchronize the presence-detect data transfer to and from the module.
50	VREF	Supply	SSTL_2 reference voltage.
5, 8, 14, 19, 30, 38, 41, 55, 58, 64, 69, 80, 88, 91	VDD	Supply	Power Supply: +2.5V ±0.2V.
2, 11, 16, 25, 35, 44, 47, 52, 61, 66, 75, 85, 94, 97	VSS	Supply	Ground.
83	DNU	—	Do Not Use: This pin is not connected on these modules, but is an assigned pin on other modules in this product family.
21 (128MB), 22	NC	—	No Connect: These pins should be left unconnected.

Functional Block

All resistor values are 22Ω unless otherwise specified. Per industry standard, Micron modules utilize various component speed grades, as referenced in the module part number guide at www.micron.com/numberguide.

Standard modules use the following DDR SDRAM devices: MT46V16M8TG (128MB); MT46V32M8TG (256MB); and MT46V64M8TG (512MB). Lead-free modules use the following DDR SDRAM devices: MT46V16M8P (128MB); MT46V32M8P (256MB); and MT46V64M8TG (512MB).

Figure 3: Functional Block Diagram

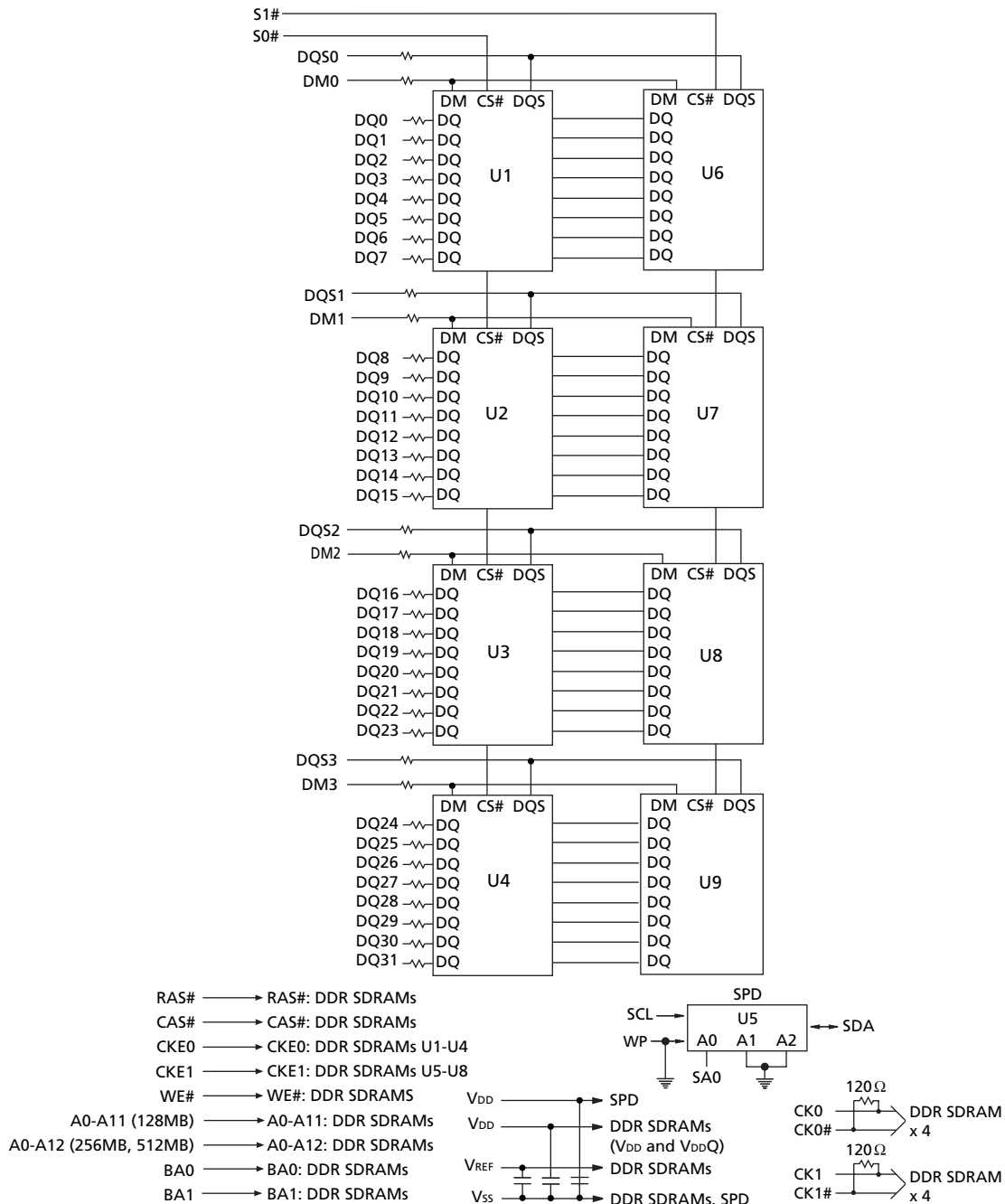

General Description

The MT8VDDT3232U, MT8VDDT6432U, and MT8VDDT12832U are high-speed CMOS, dynamic random-access, 128MB, 256MB, and 512MB memory modules organized in x32 configuration. DDR SDRAM modules use internally configured quad-bank DDR SDRAM devices.

DDR SDRAM modules use a double data rate architecture to achieve high-speed operation. The double data rate architecture is essentially a $2n$ -prefetch architecture with an interface designed to transfer two data words per clock cycle at the I/O pins. A single read or write access for the DDR SDRAM module effectively consists of a single $2n$ -bit wide, one-clock-cycle data transfer at the internal DRAM core and two corresponding n -bit wide, one-half-clock-cycle data transfers at the I/O pins.

A bidirectional data strobe (DQS) is transmitted externally, along with data, for use in data capture at the receiver. DQS is an intermittent strobe transmitted by the DDR SDRAM during READs and by the memory controller during WRITEs. DQS is edge-aligned with data for READs and center-aligned with data for WRITEs.

DDR SDRAM modules operate from differential clock inputs (CK and CK#); the crossing of CK going HIGH and CK# going LOW will be referred to as the positive edge of CK. Commands (address and control signals) are registered at every positive edge of CK. Input data is registered on both edges of DQS, and output data is referenced to both edges of DQS, as well as to both edges of CK.

Read and write accesses to DDR SDRAM modules are burst oriented; accesses start at a selected location and continue for a programmed number of locations in a programmed sequence. Accesses begin with the registration of an ACTIVE command, which is then followed by a READ or WRITE command. The address bits registered coincident with the ACTIVE command are used to select the device bank and row to be accessed (BA0, BA1 select device bank; A0–A11 select device row for 128MB module, A0–A12 select device row for 256MB and 512MB modules). The address bits registered coincident with the READ or WRITE command are used to select the device bank and the starting device column location for the burst access (BA0, BA1; A0–A9 for 128MB and 256MB, or A0–A9, A11 for 512MB).

DDR SDRAM modules provide for programmable READ or WRITE burst lengths of 2, 4, or 8 locations. An auto precharge function may be enabled to provide a self-timed row precharge that is initiated at the end of the burst access.

The pipelined, multibank architecture of DDR SDRAM modules allows for concurrent operation, thereby providing high effective bandwidth by hiding row precharge and activation time.

An auto refresh mode is provided, along with a power-saving power-down mode. All inputs are compatible with the JEDEC Standard for SSTL_2. All outputs are SSTL_2, Class II compatible. For more information regarding DDR SDRAM operation, refer to the 128Mb, 256Mb, or 512Mb DDR SDRAM component data sheets.

Serial Presence-Detect Operation

DDR SDRAM modules incorporate serial presence-detect (SPD). The SPD function is implemented using a 2,048-bit EEPROM. This nonvolatile storage device contains 256 bytes. The first 128 bytes can be programmed by Micron to identify the module type and various SDRAM organizations and timing parameters. The remaining 128 bytes of storage are available for use by the customer. System READ/WRITE operations between the master (system logic) and the slave EEPROM device (DIMM) occur via a standard I²C

bus using the DIMM's SCL (clock) and SDA (data) signals, together with SA (2:0), which provide eight unique DIMM/EEPROM addresses. Write protect (WP) is tied to ground on the module, permanently disabling hardware write protect.

Mode Register Definition

The mode register is used to define the specific mode of operation of DDR SDRAM devices. This definition includes the selection of a burst length, a burst type, a CAS latency and an operating mode, as shown in Figure 4, Mode Register Definition Diagram, on page 12. The mode register is programmed via the MODE REGISTER SET command (with BA0 = 0 and BA1 = 0) and will retain the stored information until it is programmed again or the device loses power (except for bit A8, which is self-clearing).

Reprogramming the mode register will not alter the contents of the memory, provided it is performed correctly. The mode register must be loaded (reloaded) when all device banks are idle and no bursts are in progress, and the controller must wait the specified time before initiating the subsequent operation. Violating either of these requirements will result in unspecified operation.

Mode register bits A0–A2 specify the burst length, A3 specifies the type of burst (sequential or interleaved), A4–A6 specify the CAS latency, and A7–A11 (128MB, 256MB) or A7–A12 (512MB) specify the operating mode.

Burst Length

Read and write accesses to DDR SDRAM devices are burst oriented, with the burst length being programmable, as shown in Figure 4, Mode Register Definition Diagram. The burst length determines the maximum number of column locations that can be accessed for a given READ or WRITE command. Burst lengths of 2, 4, or 8 locations are available for both the sequential and the interleaved burst types.

Reserved states should not be used, as unknown operation or incompatibility with future versions may result.

When a READ or WRITE command is issued, a block of columns equal to the burst length is effectively selected. All accesses for that burst take place within this block, meaning that the burst will wrap within the block if a boundary is reached. The block is uniquely selected by A1–A9 (128MB, 256MB) or A1–A9, A11 (512MB) when the burst length is set to two, by A2–A9 (128MB, 256MB) or A2–A9, A11 (512MB) when the burst length is set to four and by A3–A9 (128MB, 256MB) or A3–A9, A11 (512MB) when the burst length is set to eight. The remaining (least significant) address bit(s) is (are) used to select the starting location within the block. The programmed burst length applies to both READ and WRITE bursts.

Burst Type

Accesses within a given burst may be programmed to be either sequential or interleaved; this is referred to as the burst type and is selected via bit M3.

The ordering of accesses within a burst is determined by the burst length, the burst type and the starting column address, as shown in Table 5, Burst Definition Table, on page 13.

Read Latency

The READ latency is the delay, in clock cycles, between the registration of a READ command and the availability of the first bit of output data. The latency can be set to 2 or 2.5 clocks, as shown in Figure 5, CAS Latency Diagram, on page 14.

If a READ command is registered at clock edge n , and the latency is m clocks, the data will be available nominally coincident with clock edge $n + m$. The CAS Latency Table indicates the operating frequencies at which each CAS latency setting can be used.

Reserved states should not be used as unknown operation or incompatibility with future versions may result.

Figure 4: Mode Register Definition Diagram

128MB Module Address Bus

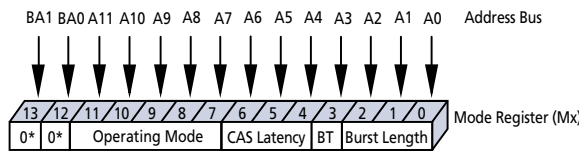

* M13 and M12 (BA1 and BA0) must be "0, 0" to select the base mode register (vs. the extended mode register).

256MB, 512MB Module Address Bus

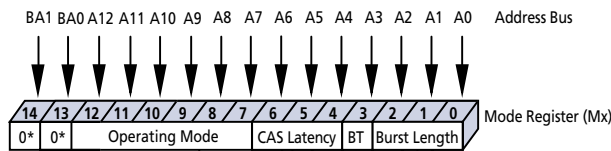

* M14 and M13 (BA1 and BA0) must be "0, 0" to select the base mode register (vs. the extended mode register).

Burst Length		
M2	M1	M0
0	0	0
0	0	1
0	1	0
0	1	1
1	0	0
1	0	1
1	1	0
1	1	1

M3	Burst Type
0	Sequential
1	Interleaved

CAS Latency		
M6	M5	M4
0	0	0
0	0	1
0	1	0
0	1	1
1	0	0
1	0	1
1	1	0
1	1	1

M12	M11	M10	M9	M8	M7	M6-M0	Operating Mode
0	0	0	0	0	0	Valid	Normal Operation
0	0	0	0	1	0	Valid	Normal Operation/Reset DLL
-	-	-	-	-	-	-	All other states reserved

Table 5: Burst Definition Table

Burst Length	Starting Column Address		Order of Accesses Within a Burst		
			Type = Sequential	Type = Interleaved	
2	A0				
	0		0-1	0-1	
	1		1-0	1-0	
4	A1 A0				
	0	0	0-1-2-3	0-1-2-3	
	0	1	1-2-3-0	1-0-3-2	
	1	0	2-3-0-1	2-3-0-1	
	1	1	3-0-1-2	3-2-1-0	
8	A2 A1 A0				
	0	0	0	0-1-2-3-4-5-6-7	0-1-2-3-4-5-6-7
	0	0	1	1-2-3-4-5-6-7-0	1-0-3-2-5-4-7-6
	0	1	0	2-3-4-5-6-7-0-1	2-3-0-1-6-7-4-5
	0	1	1	3-4-5-6-7-0-1-2	3-2-1-0-7-6-5-4
	1	0	0	4-5-6-7-0-1-2-3	4-5-6-7-0-1-2-3
	1	0	1	5-6-7-0-1-2-3-4	5-4-7-6-1-0-3-2
	1	1	0	6-7-0-1-2-3-4-5	6-7-4-5-2-3-0-1
	1	1	1	7-0-1-2-3-4-5-6	7-6-5-4-3-2-1-0

- Notes:
1. For a burst length of two, A1–A_i select the two-data-element block; A0 selects the first access within the block.
 2. For a burst length of four, A2–A_i select the four-data-element block; A0–A1 select the first access within the block.
 3. For a burst length of eight, A3–A_i select the eight-data-element block; A0–A2 select the first access within the block.
 4. Whenever a boundary of the block is reached within a given sequence above, the following access wraps within the block.
 5. $i = 9$ (128MB, 256MB)
 $i = 9, 11$ (512MB)

Table 6: CAS Latency (CL) Table

Speed	Allowable Operating Clock Frequency (MHz)	
	CL = 2	CL = 2.5
-6	$75 \leq f \leq 133$	$75 \leq f \leq 167$
-75Z	$75 \leq f \leq 133$	$75 \leq f \leq 133$
-75	$75 \leq f \leq 100$	$75 \leq f \leq 133$

Figure 5: CAS Latency Diagram

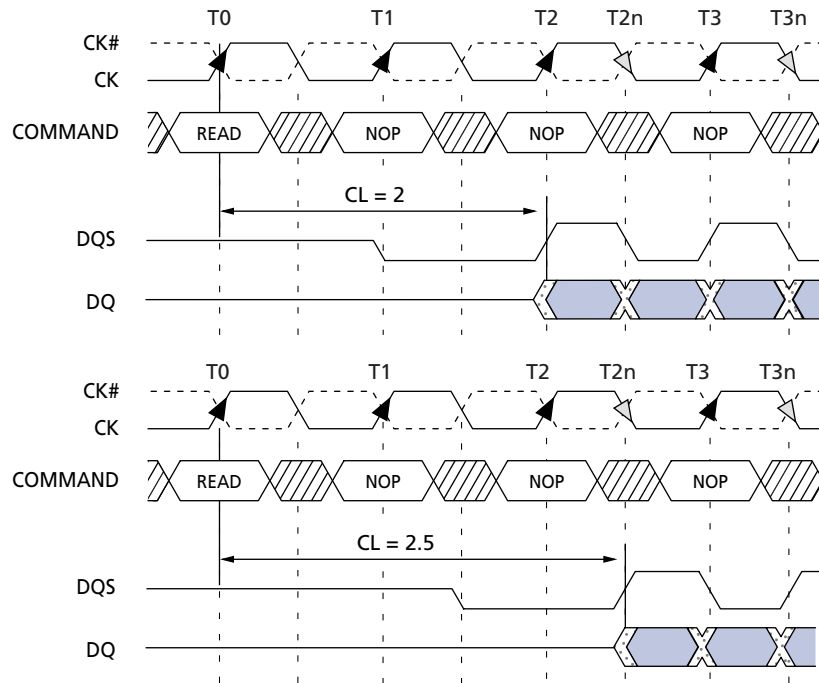

Burst Length = 4 in the cases shown
Shown with nominal t_{AC} , t_{DQSCK} , and t_{DQSQ}

TRANSITIONING DATA DON'T CARE

Operating Mode

The normal operating mode is selected by issuing a MODE REGISTER SET command with bits A7–A11 (128MB, 256MB), or A7–A12 (512MB) each set to zero, and bits A0–A6 set to the desired values. A DLL reset is initiated by issuing a MODE REGISTER SET command with bits A7 and A9–A11 (128MB, 256MB), or A7 and A9–A12 (512MB) each set to zero, bit A8 set to one, and bits A0–A6 set to the desired values. Although not required by the Micron device, JEDEC specifications recommend when a LOAD MODE REGISTER command is issued to reset the DLL, it should always be followed by a LOAD MODE REGISTER command to select normal operating mode.

All other combinations of values for A7–A11 (128MB, 256MB), or A7–A12 (512MB) are reserved for future use and/or test modes. Test modes and reserved states should not be used because unknown operation or incompatibility with future versions may result.

Extended Mode Register

The extended mode register controls functions beyond those controlled by the mode register; these additional functions are DLL enable/disable and output drive strength. These functions are controlled via the bits shown in Figure 6, Extended Mode Register Definition Diagram. The extended mode register is programmed via the LOAD MODE REGISTER command to the mode register (with BA0 = 1 and BA1 = 0) and will retain the stored information until it is programmed again or the device loses power. The enabling of the DLL should always be followed by a LOAD MODE REGISTER command to the mode register (BA0/BA1 both LOW) to reset the DLL.

The extended mode register must be loaded when all device banks are idle and no bursts are in progress, and the controller must wait the specified time before initiating any subsequent operation. Violating either of these requirements could result in unspecified operation.

DLL Enable/Disable

The DLL must be enabled for normal operation. DLL enable is required during power-up initialization and upon returning to normal operation after having disabled the DLL for the purpose of debug or evaluation. (When the device exits self refresh mode, the DLL is enabled automatically.) Any time the DLL is enabled, 200 clock cycles with CKE HIGH must occur before a READ command can be issued.

Figure 6: Extended Mode Register Definition Diagram

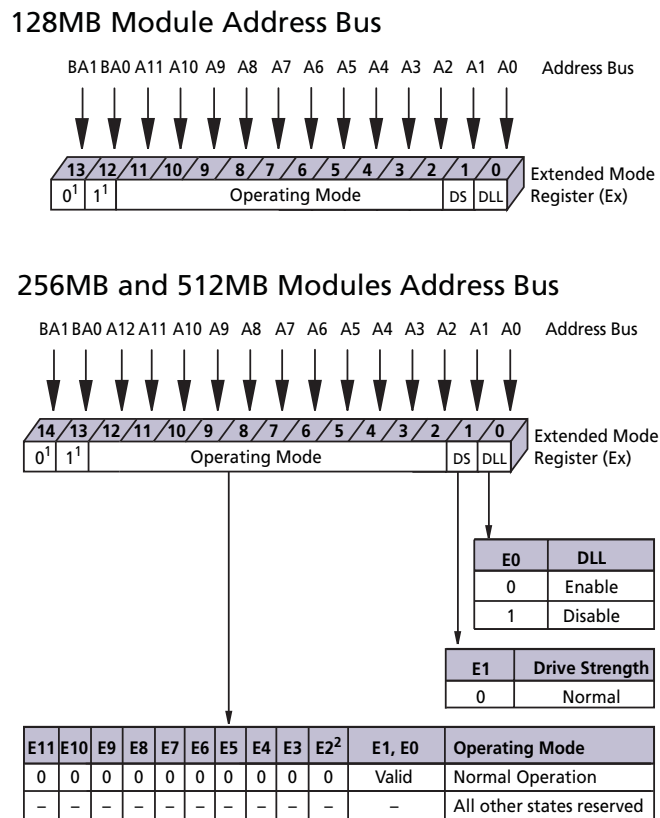

- Notes: 1. BA1 and BA0 (E13 and E12 for 128MB, or E14 and E13 for 256MB, 512MB) must be "0, 1" to select the Extended Mode Register (vs. the base Mode Register).
2. QFC# is not supported.

Commands

Table 7, Commands Truth Table, and Table 8, DM Operation Truth Table, provide a general reference of available commands. For a more detailed description of commands and operations, refer to the 128Mb, 256Mb, or 512Mb DDR SDRAM component data sheet.

Table 7: Commands Truth Table

CKE is HIGH for all commands shown except SELF REFRESH; all states and sequences not shown are illegal or reserved

Name (Function)	CS#	RAS#	CAS#	WE#	Address	Notes
DESELECT (NOP)	H	X	X	X	X	1
NO OPERATION (NOP)	L	H	H	H	X	1
ACTIVE (Select bank and activate row)	L	L	H	H	Bank/Row	2
READ (Select bank and column, and start READ burst)	L	H	L	H	Bank/Col	3
WRITE (Select bank and column, and start WRITE burst)	L	H	L	L	Bank/Col	3
BURST TERMINATE	L	H	H	L	X	4
PRECHARGE (Deactivate row in bank or banks)	L	L	H	L	Code	5
AUTO REFRESH or SELF REFRESH (Enter self refresh mode)	L	L	L	H	X	6, 7
LOAD MODE REGISTER	L	L	L	L	Op-Code	8

- Notes:
1. Deselect and NOP are functionally interchangeable.
 2. BA0–BA1 provide device bank address and A0–A11 (128MB) or A0–A12 (256MB, 512MB) provide row address.
 3. BA0–BA1 provide device bank address; A0–A9 (128MB, 256MB) or A0–A9, A11 (512MB) provide column address; A10 HIGH enables the auto precharge feature (nonpersistent), and A10 LOW disables the auto precharge feature.
 4. Applies only to read bursts with auto precharge disabled; this command is undefined (and should not be used) for READ bursts with auto precharge enabled and for WRITE bursts.
 5. A10 LOW: BA0–BA1 determine which device bank is precharged. A10 HIGH: all device banks are precharged and BA0–BA1 are “Don’t Care.”
 6. This command is AUTO REFRESH if CKE is HIGH, SELF REFRESH if CKE is LOW.
 7. Internal refresh counter controls row addressing; all inputs and I/Os are “Don’t Care” except for CKE.
 8. BA0–BA1 select either the mode register or the extended mode register (BA0 = 0, BA1 = 0 select the mode register; BA0 = 1, BA1 = 0 select extended mode register; other combinations of BA0–BA1 are reserved). A0–A11 (128MB) or A0–A12 (256MB, 512MB) provide the op-code to be written to the selected mode register.

Table 8: DM Operation Truth Table

Used to mask write data; provided coincident with the corresponding data

Name (Function)	DM	DQs
WRITE Enable	L	Valid
WRITE Inhibit	H	X

Parameter Tables

Absolute Maximum Ratings

Stresses greater than those listed may cause permanent damage to the device. This is a stress rating only, and functional operation of the device at these or any other conditions above those indicated in the operational sections of this specification is not implied. Exposure to absolute maximum rating conditions for extended periods may affect reliability.

Voltage on VDD Supply Relative to VSS	-1V to +3.6V
Voltage on VREF and Inputs Relative to VSS	-1V to +3.6V
Voltage on I/O Pins Relative to VSS	-0.5V to VDD +0.5V
Operating Temperature,	
T _A (commercial - ambient)	0°C to +70°C
T _A (industrial - ambient)	-40°C to +85°C
Storage Temperature (plastic)	-55°C to +150°C
Short Circuit Output Current	50mA

Table 9: DC Electrical Characteristics and Operating Conditions

Notes: 1–5, 14, 48; notes appear on pages 23–27; 0°C ≤ T_A ≤ +70°C

Parameter/Condition	Symbol	Min	Max	Units	Notes	
Supply Voltage	VDD	2.3	2.7	V	32	
I/O Supply Voltage	VDD	2.3	2.7	V	32, 39	
I/O Reference Voltage	VREF	0.49 × VDD	0.51 × VDD	V	6, 39	
I/O Termination Voltage (system)	VTT	VREF - 0.04	VREF + 0.04	V	7, 39	
Input High (Logic 1) Voltage	V _{IH} (DC)	VREF + 0.15	VDD + 0.3	V	25	
Input Low (Logic 0) Voltage	V _{IL} (DC)	-0.3	VREF - 0.15	V	25	
INPUT LEAKAGE CURRENT Any input 0V ≤ V _{IN} ≤ VDD, VREF pin 0V ≤ V _{IN} ≤ 1.35V (All other pins not under test = 0V)	Command/ Address, RAS#, CAS#, WE#	-16	16	μA	47	
	CKE0, CKE1, S0#, S1# CK, CK#	-8	8			
	DM	-4	4			
OUTPUT LEAKAGE CURRENT (DQs are disabled; 0V ≤ V _{OUT} ≤ VDD)	DQ, DQS	I _{OZ}	-10	10	μA	47
OUTPUT LEVELS						
High Current (V _{OUT} = VDD-0.373V, minimum VREF, minimum VTT)	I _{OH}	-16.8	–	mA	33, 34	
Low Current (V _{OUT} = 0.373V, maximum VREF, maximum VTT)	I _{OL}	16.8	–	mA		

Table 10: AC Input Operating Conditions

Notes: 1–5, 14, 48, 49; notes appear on pages 23–27; 0°C ≤ T_A ≤ +70°C; VDD = +2.5V ±0.2V

Parameter/Condition	Symbol	Min	Max	Units	Notes
Input High (Logic 1) Voltage	V _{IH} (AC)	VREF + 0.310	–	V	12, 25, 35
Input Low (Logic 0) Voltage	V _{IL} (AC)	–	VREF - 0.310	V	12, 25, 35
I/O Reference Voltage	VREF (AC)	0.49 × VDD	0.51 × VDD	V	6

Table 11: IDD Specifications and Conditions – 128MB

DDR SDRAM components only

 Notes: 1–5, 14, 48; notes appear on pages 23–27; $0^{\circ}\text{C} \leq T_A \leq +70^{\circ}\text{C}$; $V_{DD} = +2.5\text{V} \pm 0.2\text{V}$

Parameter/Condition	Symbol	Max		Units	Notes	
		-6	-75Z/ -75			
OPERATING CURRENT: One device bank; Active-Precharge; $t_{RC} = t_{RC}(\text{MIN})$; $t_{CK} = t_{CK}(\text{MIN})$; DQ, DM and DQS inputs changing once per clock cycle; Address and control inputs changing once every two clock cycles	IDD0 ^a	512	432	mA	20, 42	
OPERATING CURRENT: One device bank; Active -Read Precharge; Burst = 2; $t_{RC} = t_{RC}(\text{MIN})$; $t_{CK} = t_{CK}(\text{MIN})$; IOUT = 0mA; Address and control inputs changing once per clock cycle	IDD1 ^a	552	492	mA	20, 42	
PRECHARGE POWER-DOWN STANDBY CURRENT: All device banks idle; Power-down mode; $t_{CK} = t_{CK}(\text{MIN})$; CKE = (LOW)	IDD2P ^b	24	24	mA	21, 28, 44	
IDLE STANDBY CURRENT: CS# = HIGH; All device banks idle; $t_{CK} = t_{CK}(\text{MIN})$; CKE = HIGH; Address and other control inputs changing once per clock cycle. $V_{IN} = V_{REF}$ for DQ, DQS, and DM	IDD2F ^b	360	320	mA	45	
ACTIVE POWER-DOWN STANDBY CURRENT: One device bank active; Power-down mode; $t_{CK} = t_{CK}(\text{MIN})$; CKE = LOW	IDD3P ^b	200	160	mA	21, 28, 44	
ACTIVE STANDBY CURRENT: CS# = HIGH; CKE = HIGH; One device bank; Active-Precharge; $t_{RC} = t_{RAS}(\text{MAX})$; $t_{CK} = t_{CK}(\text{MIN})$; DQ, DM and DQS inputs changing twice per clock cycle; Address and other control inputs changing once per clock cycle	IDD3N ^b	400	360	mA	41	
OPERATING CURRENT: Burst = 2; Reads; Continuous burst; One device bank active; Address and control inputs changing once per clock cycle; $t_{CK} = t_{CK}(\text{MIN})$; IOUT = 0mA	IDD4R ^a	572	512	mA	20, 42	
OPERATING CURRENT: Burst = 2; Writes; Continuous burst; One device bank active; Address and control inputs changing once per clock cycle; $t_{CK} = t_{CK}(\text{MIN})$; DQ, DM, and DQS inputs changing twice per clock cycle	IDD4W ^a	572	492	mA	20	
AUTO REFRESH CURRENT	$t_{REFC} = t_{RFC}(\text{MIN})$	IDD5 ^b	2,120	1,760	mA	20, 44
	$t_{REFC} = 15.625\mu\text{s}$	IDD5A ^b	40	40	mA	24, 44
SELF REFRESH CURRENT: CKE \leq 0.2V	IDD6 ^b	24	16	mA	9	
OPERATING CURRENT: Four device bank interleaving READs (BL = 4) with auto precharge, $t_{RC} = t_{RC}(\text{MIN})$; $t_{CK} = t_{CK}(\text{MIN})$; Address and control inputs change only during Active READ or WRITE commands	IDD7 ^a	1,432	1,312	mA	20, 43	

a: Value calculated as one module rank in this operating condition, and all other module ranks in IDD2p (CKE LOW) mode.

b: Value calculated reflects all module ranks in this operating condition.

Table 12: IDD Specifications and Conditions – 256MB

DDR SDRAM components only

 Notes: 1–5, 14, 48; notes appear on pages 23–27; $0^{\circ}\text{C} \leq T_A \leq +70^{\circ}\text{C}$; $V_{DD} = +2.5\text{V} \pm 0.2\text{V}$

Parameter/Condition	Symbol	Max		Units	Notes	
		-6	-75/ -75			
OPERATING CURRENT: One device bank; Active-Precharge; $t_{RC} = t_{RC}(\text{MIN})$; $t_{CK} = t_{CK}(\text{MIN})$; DQ, DM and DQS inputs changing once per clock cycle; Address and control inputs changing once every two clock cycles	IDD0 ^a	516	496	mA	20, 42	
OPERATING CURRENT: One device bank; Active -Read Precharge; Burst = 4; $t_{RC} = t_{RC}(\text{MIN})$; $t_{CK} = t_{CK}(\text{MIN})$; I _{OUT} = 0mA; Address and control inputs changing once per clock cycle	IDD1 ^a	696	596	mA	20, 42	
PRECHARGE POWER-DOWN STANDBY CURRENT: All device banks idle; Power-down mode; $t_{CK} = t_{CK}(\text{MIN})$; CKE = (LOW)	IDD2P ^b	32	32	mA	21, 28, 44	
IDLE STANDBY CURRENT: CS# = HIGH; All device banks idle; $t_{CK} = t_{CK}(\text{MIN})$; CKE = HIGH; Address and other control inputs changing once per clock cycle. V _{IN} = V _{REF} for DQ, DQS, and DM	IDD2F ^b	400	360	mA	45	
ACTIVE POWER-DOWN STANDBY CURRENT: One device bank active; Power-down mode; $t_{CK} = t_{CK}(\text{MIN})$; CKE = LOW	IDD3P ^b	240	200	mA	21, 28, 44	
ACTIVE STANDBY CURRENT: CS# = HIGH; CKE = HIGH; One device bank; Active-Precharge; $t_{RC} = t_{RAS}(\text{MAX})$; $t_{CK} = t_{CK}(\text{MIN})$; DQ, DM and DQS inputs changing twice per clock cycle; Address and other control inputs changing once per clock cycle	IDD3N ^b	480	400	mA	41	
OPERATING CURRENT: Burst = 2; Reads; Continuous burst; One device bank active; Address and control inputs changing once per clock cycle; $t_{CK} = t_{CK}(\text{MIN})$; I _{OUT} = 0mA	IDD4R ^a	716	616	mA	20, 42	
OPERATING CURRENT: Burst = 2; Writes; Continuous burst; One device bank active; Address and control inputs changing once per clock cycle; $t_{CK} = t_{CK}(\text{MIN})$; DQ, DM, and DQS inputs changing twice per clock cycle	IDD4W ^a	716	616	mA	20	
AUTO REFRESH CURRENT	$t_{REFC} = t_{RFC}(\text{MIN})$	IDD5 ^b	2,040	1,880	mA	20, 44
	$t_{REFC} = 7.8125\mu\text{s}$	IDD5A ^b	48	48	mA	24, 44
SELF REFRESH CURRENT: CKE \leq 0.2V	IDD6 ^b	32	32	mA	9	
OPERATING CURRENT: Four device bank interleaving READs (BL = 4) with auto precharge, $t_{RC} = t_{RC}(\text{MIN})$; $t_{CK} = t_{CK}(\text{MIN})$; Address and control inputs change only during Active READ or WRITE commands	IDD7 ^a	1,656	1,416	mA	20, 43	

a: Value calculated as one module rank in this operating condition, and all other module ranks in IDD2p (CKE LOW) mode.

b: Value calculated reflects all module ranks in this operating condition.

Table 13: IDD Specifications and Conditions – 512MB

DDR SDRAM components only

Notes: 1–5, 14, 48; notes appear on pages 23–27; $0^{\circ}\text{C} \leq T_A \leq +70^{\circ}\text{C}$; $V_{DD} = +2.5\text{V} \pm 0.2\text{V}$

Parameter/Condition	Symbol	Max		Units	Notes	
		-6	-75/ -75			
OPERATING CURRENT: One device bank; Active-Precharge; $t_{RC} = t_{RC}(\text{MIN})$; $t_{CK} = t_{CK}(\text{MIN})$; DQ, DM and DQS inputs changing once per clock cycle; Address and control inputs changing once every two clock cycles	IDD0 ^a	540	480	mA	20, 42	
OPERATING CURRENT: One device bank; Active -Read Precharge; Burst = 4; $t_{RC} = t_{RC}(\text{MIN})$; $t_{CK} = t_{CK}(\text{MIN})$; IOUT= 0mA; Address and control inputs changing once per clock cycle	IDD1 ^a	660	600	mA	20, 42	
PRECHARGE POWER-DOWN STANDBY CURRENT: All device banks idle; Power-down mode; $t_{CK} = t_{CK}(\text{MIN})$; CKE = (LOW)	IDD2P ^b	40	40	mA	21, 28, 44	
IDLE STANDBY CURRENT: CS# = HIGH; All device banks idle; $t_{CK} = t_{CK}(\text{MIN})$; CKE = HIGH; Address and other control inputs changing once per clock cycle. $V_{IN} = V_{REF}$ for DQ, DQS, and DM	IDD2F ^b	360	320	mA	45	
ACTIVE POWER-DOWN STANDBY CURRENT: One device bank active; Power-down mode; $t_{CK} = t_{CK}(\text{MIN})$; CKE = LOW	IDD3P ^b	280	240	mA	21, 28, 44	
ACTIVE STANDBY CURRENT: CS# = HIGH; CKE = HIGH; One device bank; Active-Precharge; $t_{RC} = t_{RAS}(\text{MAX})$; $t_{CK} = t_{CK}(\text{MIN})$; DQ, DM and DQS inputs changing twice per clock cycle; Address and other control inputs changing once per clock cycle	IDD3N ^b	400	360	mA	41	
OPERATING CURRENT: Burst = 2; Reads; Continuous burst; One device bank active; Address and control inputs changing once per clock cycle; $t_{CK} = t_{CK}(\text{MIN})$; IOUT = 0mA	IDD4R ^a	680	600	mA	20, 42	
OPERATING CURRENT: Burst = 2; Writes; Continuous burst; One device bank active; Address and control inputs changing once per clock cycle; $t_{CK} = t_{CK}(\text{MIN})$; DQ, DM, and DQS inputs changing twice per clock cycle	IDD4W ^a	720	560	mA	20	
AUTO REFRESH CURRENT	$t_{REFC} = t_{RFC}(\text{MIN})$	IDD5 ^b	2,320	2,240	mA	20, 44
	$t_{REFC} = 7.8125\mu\text{s}$	IDD5A ^b	80	80	mA	24, 44
SELF REFRESH CURRENT: CKE \leq 0.2V		IDD6 ^b	40	40	mA	9
OPERATING CURRENT: Four device bank interleaving READs (BL = 4) with auto precharge, $t_{RC} = t_{RC}(\text{MIN})$; $t_{CK} = t_{CK}(\text{MIN})$; Address and control inputs change only during Active READ or WRITE commands	IDD7 ^a	1,640	1,420	mA	20, 43	

a: Value calculated as one module rank in this operating condition, and all other module ranks in IDD2p (CKE LOW) mode.

b: Value calculated reflects all module ranks in this operating condition.



Table 14: Capacitance (All Modules)

Note: 11; notes appear on pages 23–27

Parameter	Symbol	Min	Max	Units
Input/Output Capacitance: DQ, DQS, DM	C _{IO}	8	10	pF
Input Capacitance: Command and Address	C _{I1}	16	24	pF
Input Capacitance: S#, CK/CK#, CKE	C _{I2}	8	12	pF

Table 15: Component Electrical Characteristics and Recommended AC Operating Conditions

Notes: 1–5, 12–15, 29, 48; notes appear on pages 23–27; 0°C ≤ T_A ≤ +70°C; V_{DD} = +2.5V ±0.2V

AC Characteristics		-6		-75/-75				
Parameter	Symbol	Min	Max	Min	Max	Units	Notes	
Access window of DQ from CK/CK#	t ^{AC}	-0.7	+0.7	-0.75	+0.75	ns		
CK high-level width	t ^{CH}	0.45	0.55	0.45	0.55	t ^{CK}	26	
CK low-level width	t ^{CL}	0.45	0.55	0.45	0.55	t ^{CK}	26	
Clock cycle time	CL = 2.5	t ^{CK} (2.5)	6	13	7.5	13	ns	40, 46
	CL = 2	t ^{CK} (2)	7.5	13	7.5/10	13	ns	40, 46
DQ and DM input hold time relative to DQS	t ^{DH}	0.45		0.5		ns	23, 27	
DQ and DM input setup time relative to DQS	t ^{DS}	0.45		0.5		ns	23, 27	
DQ and DM input pulse width (for each input)	t ^{DIPW}	1.75		1.75		ns	27	
Access window of DQS from CK/CK#	t ^{DQSCK}	-0.6	+0.6	-0.75	+0.75	ns		
DQS input high pulse width	t ^{DQSH}	0.35		0.35		t ^{CK}		
DQS input low pulse width	t ^{DQSL}	0.35		0.35		t ^{CK}		
DQS-DQ skew, DQS to last DQ valid, per group, per access	t ^{DQSQ}		0.45		0.5	ns	22, 23	
Write command to first DQS latching transition	t ^{DQSS}	0.75	1.25	0.75	1.25	t ^{CK}		
DQS falling edge to CK rising - setup time	t ^{DSS}	0.2		0.2		t ^{CK}		
DQS falling edge from CK rising - hold time	t ^{DSH}	0.2		0.2		t ^{CK}		
Half clock period	t ^{HP}	t ^{CH} , t ^{CL}		t ^{CH} , t ^{CL}		ns	30	
Data-out high-impedance window from CK/CK#	t ^{HZ}		+0.70		+0.75	ns	16, 37	
Data-out low-impedance window from CK/CK#	t ^{LZ}	-0.7		-0.75		ns	16, 37	
Address and control input hold time (fast slew rate)	t ^{IHF}	0.75		0.90		ns	12	
Address and control input setup time (fast slew rate)	t ^{ISF}	0.75		0.90		ns	12	
Address and control input hold time (slow slew rate)	t ^{IHS}	0.8		1		ns	12	
Address and control input setup time (slow slew rate)	t ^{ISs}	0.8		1		ns	12	
Address and Control input pulse width (for each input)	t ^{IPW}	2.2		2.2		ns		
LOAD MODE REGISTER command cycle time	t ^{MRD}	12		15		ns		
DQ–DQS hold, DQS to first DQ to go non-valid, per access	t ^{QH}	t ^{HP} - t ^{QHS}		t ^{HP} - t ^{QHS}		ns	22, 23	
Data hold skew factor	t ^{QHS}		0.6		0.75	ns		
ACTIVE to PRECHARGE command	t ^{RAS}	42	70,000	40	120,000	ns	31, 49	
ACTIVE to READ with Auto precharge command	t ^{RAP}	15		20		ns		
ACTIVE to ACTIVE/AUTO REFRESH command period	t ^{RC}	60		65		ns		
AUTO REFRESH command period	t ^{RFC}	72		75		ns	44	



**128MB, 256MB, 512MB: (x32, DR) 100-Pin DDR UDIMM
Parameter Tables**

**Table 15: Component Electrical Characteristics and Recommended AC Operating Conditions
(Continued)**

AC Characteristics			-6		-75Z/-75			
Parameter		Symbol	Min	Max	Min	Max	Units	Notes
ACTIVE to READ or WRITE delay		t_{RCD}	15		20		ns	
PRECHARGE command period		t_{RP}	15		20		ns	
DQS read preamble		t_{RPRE}	0.9	1.1	0.9	1.1	t_{CK}	38
DQS read postamble		t_{RPST}	0.4	0.6	0.4	0.6	t_{CK}	38
ACTIVE bank a to ACTIVE bank b command		t_{RRD}	12		15		ns	
DQS write preamble		t_{WPRE}	0.25		0.25		t_{CK}	
DQS write preamble setup time		t_{WPRES}	0		0		ns	18, 19
DQS write postamble		t_{WPST}	0.4	0.6	0.4	0.6	t_{CK}	17
Write recovery time		t_{WR}	15		15		ns	
Internal WRITE to READ command delay		t_{WTR}	1		1		t_{CK}	
Data valid output window		na	$t_{QH} - t_{DQSQ}$		$t_{QH} - t_{DQSQ}$		ns	22
REFRESH to REFRESH command interval	128MB	t_{REFC}		140		140.6	μs	21
	256MB, 512MB			70.3		70.3	μs	21
Average periodic refresh interval	128MB	t_{REFI}		15.6		15.6	μs	21
	256MB, 512MB			7.8		7.8	μs	21
Terminating voltage delay to V_{DD}		t_{VTD}	0		0		ns	
Exit SELF REFRESH to non-READ command		t_{XSNR}	75		75		ns	
Exit SELF REFRESH to READ command		t_{XSRD}	200		200		t_{CK}	

Notes

1. All voltages referenced to VSS.
2. Tests for AC timing, IDD, and electrical AC and DC characteristics may be conducted at nominal reference/supply voltage levels, but the related specifications and device operation are guaranteed for the full voltage range specified.
3. Outputs measured with equivalent load:

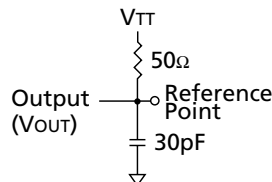

4. AC timing and IDD tests may use a V_{IL} -to- V_{IH} swing of up to 1.5V in the test environment, but input timing is still referenced to V_{REF} (or to the crossing point for CK/CK#), and parameter specifications are guaranteed for the specified AC input levels under normal use conditions. The minimum slew rate for the input signals used to test the device is 1V/ns in the range between V_{IL} (AC) and V_{IH} (AC).
5. The AC and DC input level specifications are as defined in the SSTL_2 Standard (i.e., the receiver will effectively switch as a result of the signal crossing the AC input level, and will remain in that state as long as the signal does not ring back above [below] the DC input LOW [HIGH] level).
6. V_{REF} is expected to equal $V_{DD}/2$ of the transmitting device and to track variations in the DC level of the same. Peak-to-peak noise (non-common mode) on V_{REF} may not exceed ± 2 percent of the DC value. Thus, from $V_{DD}/2$, V_{REF} is allowed $\pm 25\text{mV}$ for DC error and an additional $\pm 25\text{mV}$ for AC noise. This measurement is to be taken at the nearest V_{REF} bypass capacitor.
7. V_{TT} is not applied directly to the device. V_{TT} is a system supply for signal termination resistors, is expected to be set equal to V_{REF} and must track variations in the DC level of V_{REF} .
8. IDD is dependent on output loading and cycle rates. Specified values are obtained with minimum cycle time at $CL = 2$ for -75Z and $CL = 2.5$ for -6 and -75 with the outputs open.
9. Enables on-chip refresh and address counters.
10. IDD specifications are tested after the device is properly initialized, and is averaged at the defined cycle rate.
11. This parameter is sampled. $V_{DD} = +2.5\text{V} \pm 0.2\text{V}$, $V_{REF} = V_{SS}$, $f = 100\text{ MHz}$, $T_A = 25^\circ\text{C}$, $V_{OUT}(\text{DC}) = V_{DD}/2$, $V_{OUT}(\text{peak to peak}) = 0.2\text{V}$. DM input is grouped with I/O pins, reflecting the fact that they are matched in loading.
12. For slew rates $< 1\text{ V/ns}$ and \geq to 0.5 V/ns . If the slew rate is $< 0.5\text{ V/ns}$, timing must be derated: t_{IS} has an additional 50ps per each 100 mV/ns reduction in slew rate from 500mV/ns, while t_{IH} is unaffected. If the slew rate exceeds 4.5 V/ns, functionality is uncertain. For -6, slew rates must be $\geq 0.5\text{ V/ns}$.
13. The CK/CK# input reference level (for timing referenced to CK/CK#) is the point at which CK and CK# cross; the input reference level for signals other than CK/CK# is V_{REF} .
14. Inputs are not recognized as valid until V_{REF} stabilizes. Exception: during the period before V_{REF} stabilizes, $\text{CKE} \leq 0.3 \times V_{DD}$ is recognized as LOW.
15. The output timing reference level, as measured at the timing reference point indicated in Note 3, is V_{TT} .

16. t_{HZ} and t_{LZ} transitions occur in the same access time windows as valid data transitions. These parameters are not referenced to a specific voltage level, but specify when the device output is no longer driving (HZ) or begins driving (LZ).
17. The intent of the “Don’t Care” state after completion of the postamble is that the DQS-driven signal should either be HIGH, LOW, or High-Z and that any signal transition within the input switching region must follow valid input requirements. If DQS transitions HIGH, above DC V_{IH} (MIN) then it must not transition LOW, below DC V_{IH} , prior to t_{DQSH} (MIN).
18. This is not a device limit. The device will operate with a negative value, but system performance could be degraded due to bus turnaround.
19. It is recommended that DQS be valid (HIGH or LOW) on or before the WRITE command. The case shown (DQS going from High-Z to logic LOW) applies when no WRITES were previously in progress on the bus. If a previous WRITE was in progress, DQS could be HIGH during this time, depending on t_{DQSS} .
20. MIN (t_{RC} or t_{RFC}) for I_{DD} measurements is the smallest multiple of t_{CK} that meets the minimum absolute value for the respective parameter. t_{RAS} (MAX) for I_{DD} measurements is the largest multiple of t_{CK} that meets the maximum absolute value for t_{RAS} .
21. The refresh period 64ms. This equates to an average refresh rate of 15.625 μ s (128MB) or 7.8125 μ s (256MB, 512MB). However, an AUTO REFRESH command must be asserted at least once every 140.6 μ s (128MB) or 70.3 μ s (256MB, 512MB); burst refreshing or posting by the DRAM controller greater than eight refresh cycles is not allowed.
22. The valid data window is derived by achieving other specifications: t_{HP} ($t_{CK}/2$), t_{DQSQ} , and t_{QH} ($t_{QH} = t_{HP} - t_{QHS}$). The data valid window derates in direct proportion to the clock duty cycle and a practical data valid window can be derived. The clock is allowed a maximum duty cycle variation of 45/55, beyond which functionality is uncertain. Figure 7, Derating Data Valid Window $t_{QH} - t_{DQSQ}$, shows derating curves for duty cycles ranging between 50/50 and 45/55.
23. Each byte lane has a corresponding DQS.
24. This limit is actually a nominal value and does not result in a fail value. \overline{CKE} is HIGH during REFRESH command period (t_{RFC} [MIN]) else \overline{CKE} is LOW (i.e., during standby).
25. To maintain a valid level, the transitioning edge of the input must:
 - a. Sustain a constant slew rate from the current AC level through to the target AC level, V_{IL} (AC) or V_{IH} (AC).
 - b. Reach at least the target AC level.
 - c. After the AC target level is reached, continue to maintain at least the target DC level, V_{IL} (DC) or V_{IH} (DC).
26. JEDEC specifies CK and CK# input slew rate must be ≥ 1 V/ns (2 V/ns differentially).
27. DQ and DM input slew rates must not deviate from DQS by more than 10 percent. If the DQ/DM/DQS slew rate is less than 0.5 V/ns, timing must be derated: 50ps must be added to t_{DS} and t_{DH} for each 100 mV/ns reduction in slew rate. If slew rate exceeds 4 V/ns, functionality is uncertain. For -6, slew rates must be ≥ 0.5 V/ns.
28. V_{DD} must not vary more than 4 percent if \overline{CKE} is not active while any bank is active.
29. The clock is allowed up to ± 150 ps of jitter. Each timing parameter is allowed to vary by the same amount.

Figure 7: Derating Data Valid Window $t_{QH} - t_{(DQSQ)}$

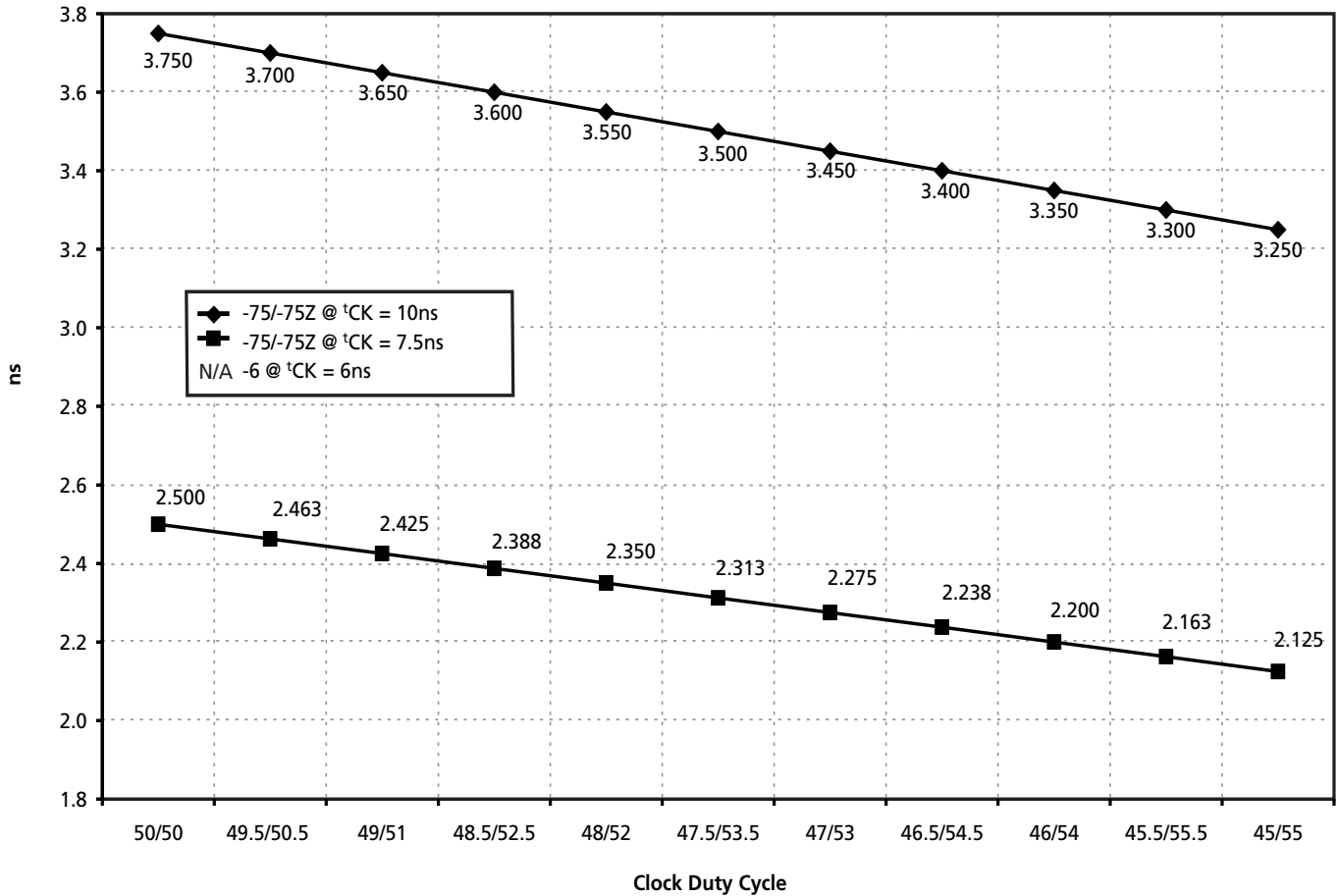

30. t_{HP} min is the lesser of t_{CL} minimum and t_{CH} minimum actually applied to the device CK and CK/ inputs, collectively during bank active.
31. READs and WRITEs with auto precharge are not allowed to be issued until t_{RAS} (MIN) can be satisfied prior to the internal precharge command being issued.
32. Any positive glitch to the nominal voltage must be less than 1/3 of the clock and not more than +400mV or 2.9 volts maximum, whichever is less. Any negative glitch must be less than 1/3 of the clock cycle and not exceed either -300mV or 2.2 volts minimum, whichever is more positive.
33. Normal Output Drive Curves:
 - a. The full variation in driver pull-down current from minimum to maximum process, temperature and voltage will lie within the outer bounding lines of the V-I curve of Figure 8, Pull-Down Characteristics.
 - b. The variation in driver pull-down current within nominal limits of voltage and temperature is expected, but not guaranteed, to lie within the inner bounding lines of the V-I curve of Figure 8, Pull-Down Characteristics.
 - c. The full variation in driver pull-up current from minimum to maximum process, temperature and voltage will lie within the outer bounding lines of the V-I curve of Figure 9, Pull-Up Characteristics.
 - d. The variation in driver pull-up current within nominal limits of voltage and temperature is expected, but not guaranteed, to lie within the inner bounding lines of the V-I curve of Figure 9, Pull-Up Characteristics.