



Chipsmall Limited consists of a professional team with an average of over 10 year of expertise in the distribution of electronic components. Based in Hongkong, we have already established firm and mutual-benefit business relationships with customers from,Europe,America and south Asia,supplying obsolete and hard-to-find components to meet their specific needs.

With the principle of “Quality Parts,Customers Priority,Honest Operation,and Considerate Service”,our business mainly focus on the distribution of electronic components. Line cards we deal with include Microchip,ALPS,ROHM,Xilinx,Pulse,ON,Everlight and Freescale. Main products comprise IC,Modules,Potentiometer,IC Socket,Relay,Connector.Our parts cover such applications as commercial,industrial, and automotives areas.

We are looking forward to setting up business relationship with you and hope to provide you with the best service and solution. Let us make a better world for our industry!



Contact us

Tel: +86-755-8981 8866 Fax: +86-755-8427 6832

Email & Skype: info@chipsmall.com Web: www.chipsmall.com

Address: A1208, Overseas Decoration Building, #122 Zhenhua RD., Futian, Shenzhen, China



2, 5 and 8-Channel Proximity/Touch Controller Data Sheet

Description

The Microchip mTouch® MTCH102/5/8 Proximity/Touch Controller with simple digital output provides an easy way to add proximity or touch detection to any application. This device family implements capacitive sensors with active guarding capability. The sensitivity and power mode can be configured through the MTSA and MTPM pins. The MTCH102/5/8 devices also use an advanced optimization algorithm to actively suppress noise from the signal to achieve reliable proximity/touch detection.

Features

- Capacitive Proximity and Touch Detection System:
 - High Signal to Noise Ratio (SNR)
 - Adjustable sensitivity with compensation for different sensor sizes
 - Multi-stage active noise suppression filters
 - Automatic environmental compensation
 - Support wide range of sensor shapes and sizes
- Simple I/O Interface with Existing System
- Smart Scan Scheduling
- Threshold Hysteresis

- Flexible Low-Power mode
- Brown-Out Protection
- Operating Voltage Range:
 - 2.05V to 3.6V
- Operating Temperature:
 - 40°C to +85°C

Typical Application

- Light Switch
- Portable Device Enabler
- White Goods and Appliance
- Office Equipment and Toys
- Display and Keypad Back-lighting Activation

TABLE 1: MTCH10X FAMILY TYPES

Device	Data Sheet Index	Sensor Input	Active Guard	Digital Output
MTCH101	(A)	1	N	1
MTCH102	(B)	2 ⁽¹⁾	Y ⁽¹⁾	2
MTCH105	(B)	5 ⁽¹⁾	Y ⁽¹⁾	5
MTCH108	(B)	8 ⁽¹⁾	Y ⁽¹⁾	8

Note 1: One of the sensor inputs can be configured as active guard output.

Data Sheet Index: (Unshaded devices are described in this document.)

- A:** DS-40001664 [MTCH101 Single-Channel Proximity Detector](#)
- B:** DS-40001793 [MTCH102/105/108 Dual-Channel Proximity/Touch Controller](#)

Note: For other small form-factor package availability and marking information, please visit <http://www.microchip.com/packaging> or contact your local sales office.

TABLE 2: PACKAGES

Packages	MSOP	TSSOP	SSOP	UDFN	QFN	UQFN
MTCH102	X	—	—	X	—	—
MTCH105	—	X	—	—	X	—
MTCH108	—	—	X	—	—	X

MTCH102/5/8

PIN DIAGRAMS

FIGURE 1: 8-LEAD MSOP, UDFN

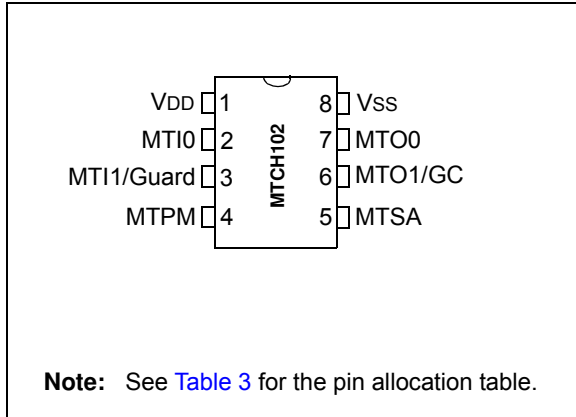

FIGURE 4: 20-LEAD SSOP

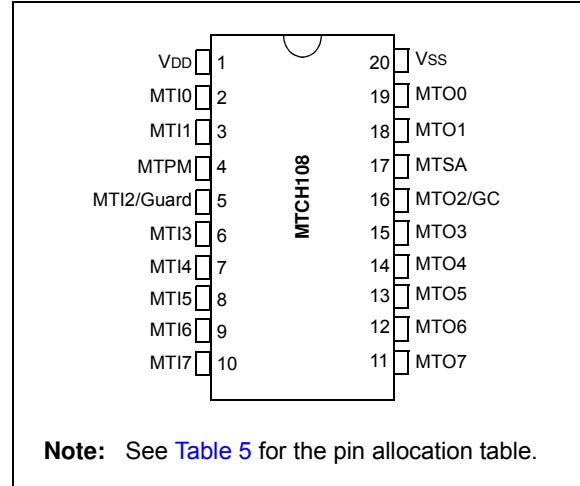

FIGURE 2: 14-LEAD TSSOP

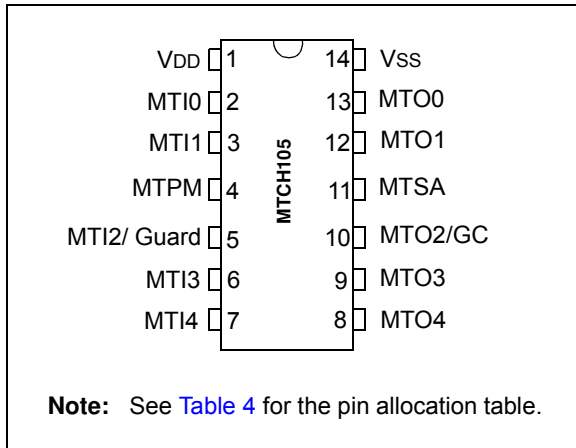

FIGURE 5: 20-LEAD UQFN

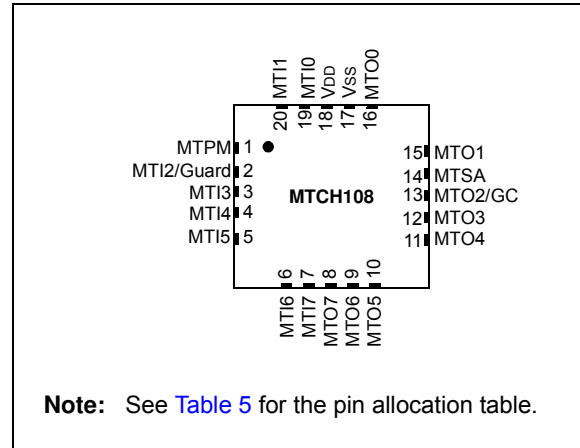
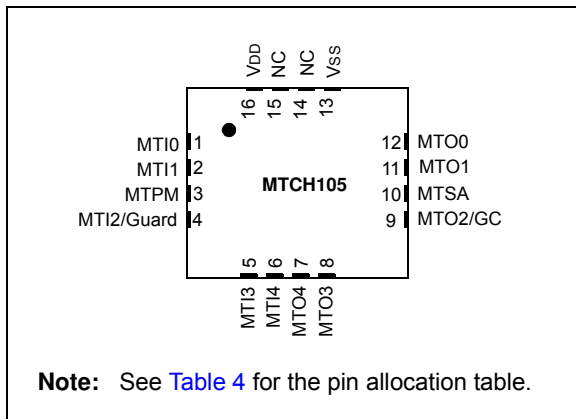

FIGURE 3: 16-LEAD QFN



PIN ALLOCATION TABLES

TABLE 3: 8-PIN DESCRIPTION (MTCH102)

Name	8-Lead MSOP and UDFN	Description
VDD	1	Power Supply Input
MTI0	2	Proximity/Touch Sensor 0 Input
MTI1/Guard	3	Proximity/Touch Sensor 1 Input/Active Guard
MTPM	4	Low-Power Mode Select
MTSA	5	Sensitivity Adjust Input
MTO1/GC	6	MTI1 Detect Output (Active-Low)/Guard Control
MTO0	7	MTI0 Detect Output (Active-Low)
Vss	8	Ground

TABLE 4: 14-/16-PIN DESCRIPTION (MTCH105)

Name	14-Lead TSSOP	16-Lead QFN	Description
VDD	1	16	Power Supply Input
MTI0	2	1	Proximity/Touch Sensor 0 Input
MTI1	3	2	Proximity/Touch Sensor 1 Input
MTPM	4	3	Low-Power Mode Select
MTI2/Guard	5	4	Proximity/Touch Sensor 2 Input/Active Guard
MTI3	6	5	Proximity/Touch Sensor 3 Input
MTI4	7	6	Proximity/Touch Sensor 4 Input
MTO4	8	7	MTI4 Detect Output (Active-Low)
MTO3	9	8	MTI3 Detect Output (Active-Low)
MTO2/GC	10	9	MTI2 Detect Output (Active-Low) /Guard Control
MTSA	11	10	Sensitivity Adjust Input
MTO1	12	11	MTI1 Detect Output (Active-Low)
MTO0	13	12	MTI0 Detect Output (Active-Low)
Vss	14	13	Ground

MTCH102/5/8

TABLE 5: 20-PIN DESCRIPTION (MTCH108)

Name	20-Lead SSOP	20-Lead UQFN	Description
VDD	1	18	Power Supply Input
MTI0	2	19	Proximity/Touch Sensor 0 Input
MTI1	3	20	Proximity/Touch Sensor 1 Input
MTPM	4	1	Low-Power Mode Select
MTI2/Guard	5	2	Proximity/Touch Sensor 2 Input/Active Guard
MTI3	6	3	Proximity/Touch Sensor 3 Input
MTI4	7	4	Proximity/Touch Sensor 4 Input
MTI5	8	5	Proximity/Touch Sensor 5 Input
MTI6	9	6	Proximity/Touch Sensor 6 Input
MTI7	10	7	Proximity/Touch Sensor 7 Input
MTO7	11	8	MTI7 Detect Output (Active-Low)
MTO6	12	9	MTI6 Detect Output (Active-Low)
MTO5	13	10	MTI5 Detect Output (Active-Low)
MTO4	14	11	MTI4 Detect Output (Active-Low)
MTO3	15	12	MTI3 Detect Output (Active-Low)
MTO2/GC	16	13	MTI2 Detect Output (Active-Low)/Guard Control
MTSA	17	14	Sensitivity Adjust Input
MTO1	18	15	MTI1 Detect Output (Active-Low)
MTO0	19	16	MTI0 Detect Output (Active-Low)
Vss	20	17	Ground

Table of Contents

1.0 Device Overview	6
2.0 Typical Circuit.....	8
3.0 Sensitivity Adjustment	9
4.0 Power Mode and Timeout Reset.....	10
5.0 Electrical Specifications.....	11
6.0 Packaging Information.....	15
Appendix	33
The Microchip Website	34
Product Identification System	35
Customer Change Notification Service	34
Customer Support.....	34

TO OUR VALUED CUSTOMERS

It is our intention to provide our valued customers with the best documentation possible to ensure successful use of your Microchip products. To this end, we will continue to improve our publications to better suit your needs. Our publications will be refined and enhanced as new volumes and updates are introduced.

If you have any questions or comments regarding this publication, please contact the Marketing Communications Department via E-mail at docerrors@microchip.com. We welcome your feedback.

Most Current Data Sheet

To obtain the most up-to-date version of this data sheet, please register at our Worldwide Website at:

<http://www.microchip.com>

You can determine the version of a data sheet by examining its literature number found on the bottom outside corner of any page. The last character of the literature number is the version number, (e.g., DS30000000A is version A of document DS30000000).

Errata

An errata sheet, describing minor operational differences from the data sheet and recommended workarounds, may exist for current devices. As device/documentation issues become known to us, we will publish an errata sheet. The errata will specify the revision of silicon and revision of document to which it applies.

To determine if an errata sheet exists for a particular device, please check with one of the following:

- Microchip's Worldwide Website; <http://www.microchip.com>
- Your local Microchip sales office (see last page)

When contacting a sales office, please specify which device, revision of silicon and data sheet (include literature number) you are using.

Customer Notification System

Register on our website at www.microchip.com to receive the most current information on all of our products.

MTCH102/5/8

1.0 DEVICE OVERVIEW

The MTCH102/5/8 provides an easy way to add proximity or touch detection to any application with human machine interface. These devices can integrate up to two, five and eight capacitive touch/proximity detection sensors which can work through plastic, wood or even metal front panels with Microchip's proprietary Metal over Capacitive technology. It also supports a wide range of conductive materials as sensors, like copper pad on PCB, silver ink, PEDOT or carbon printing on plastic film, Indium Tin Oxide (ITO) pad, wire/cable, etc.

The MTCH102/5/8 uses a sophisticated scan optimization algorithm to actively attenuate noise from the signal. The sensitivity adjustment and flexible power mode allow users to easily configure the device

at run-time. An active-low output will communicate the state of the sensors to a host/master MCU or drive an indication LED.

FIGURE 1-1: MTCH102/5/8 BLOCK DIAGRAM

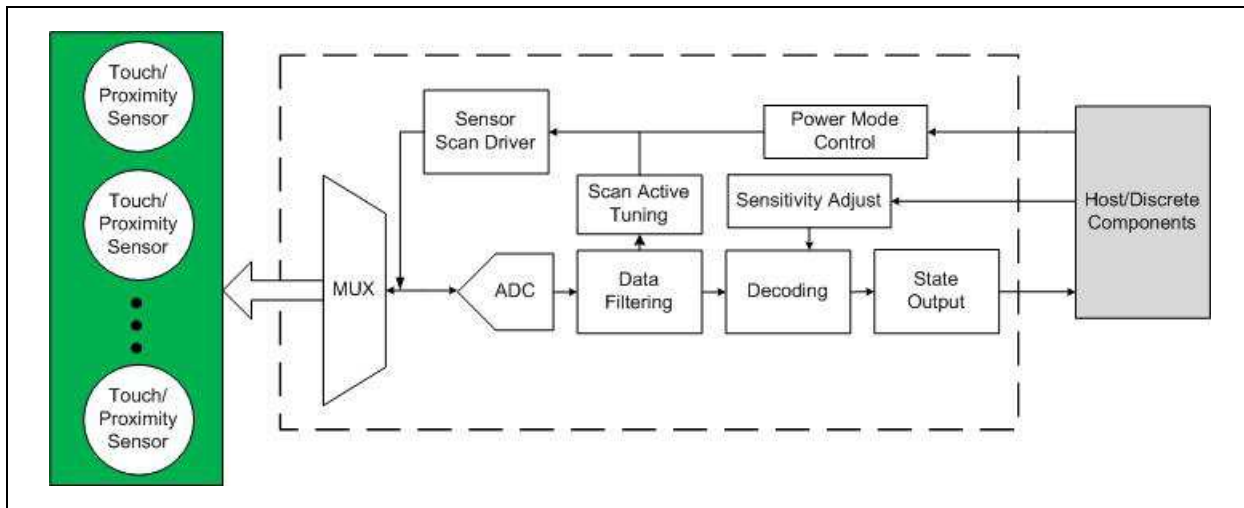

1.1 Pin Description

MTIx

Connect the sensor to this input. An additional resistor of at least 4.7 kΩ is recommended for best noise immunity. Sensors work best when the base capacitance is minimized. This will maximize the percentage change in capacitance when a finger is added to the circuit. The recommended sensor capacitance is 5pF to 50pF.

MTOx

The MTOx pin is an open-drain output which reports the touch/proximity state of the corresponding MTIx input. A pull-up resistor is required on each output. The MTOx will pull the line low when a touch/proximity event happens and release the line when the touch/proximity is released.

Guard

The Guard function is multiplexed with one of the MTIx pins. If the GC pin is floating, the Guard pin will function as a standard MTIx sensor. If the GC pin is grounded, the Guard pin will output a signal in-phase with the other sensors being scanned. This has several advantages, such as providing a mutual capacitance coupling to the sensors to increase sensitivity, and providing a low-impedance trace near the sensor to absorb noise. The active guard layout should encircle the sensor and its traces so that it will shield the sensor. For more information about guarding and layout guidelines, see application notes "mTouch® Sensing Solution Acquisition Methods Capacitive Voltage Divider" (AN1478) and "Techniques for Robust Touch Sensing Design" (AN1334).

GC

The GC (Guard Control) is multiplexed with one of the MTOx pins. By grounding the GC pin, the active guard signal will be enabled on the Guard pin.

MTSA

The MTSA pin is an input that determines the sensitivity of touch/proximity sensors. Applying VDD will give the lowest sensitivity while applying VSS will give the highest.

MTPM

The MTPM pin is an input that determines the power mode of MTCH10X devices. By connecting VSS to the MTPM pin, the device will operate in Low-Power mode. See [Figure 5-1](#) for current consumption and response time specifications. When applying VDD on the MTCH10X MTPM pin, the device will scan the sensors at the fastest possible sampling rate. Host-controlled sampling rates are available using the Smart Scan Scheduling feature described in [Section 4.0, Power Mode and Timeout Reset](#).

MTCH102/5/8

2.0 TYPICAL CIRCUIT

The MTCH102 is used as an example to show two typical circuits for MTCH10X devices in the following figures. For more information about capacitive sensor layout guidance, refer to “Techniques for Robust Touch Sensing Design” (AN1334).

FIGURE 2-1: TWO SENSORS AND NO ACTIVE GUARD CIRCUIT

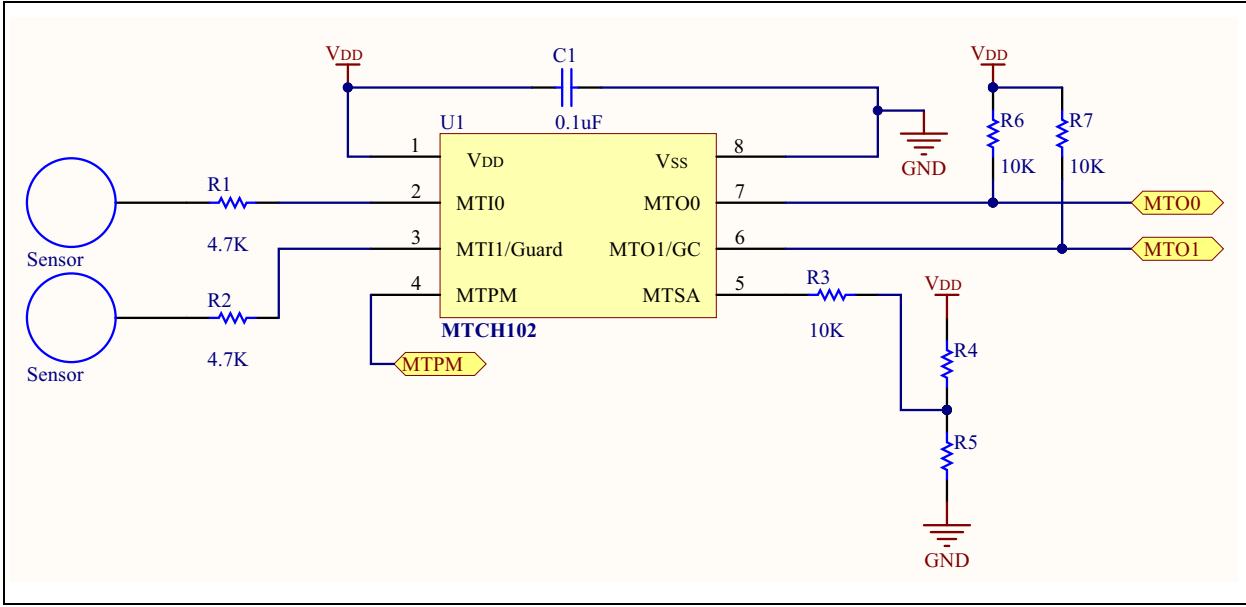
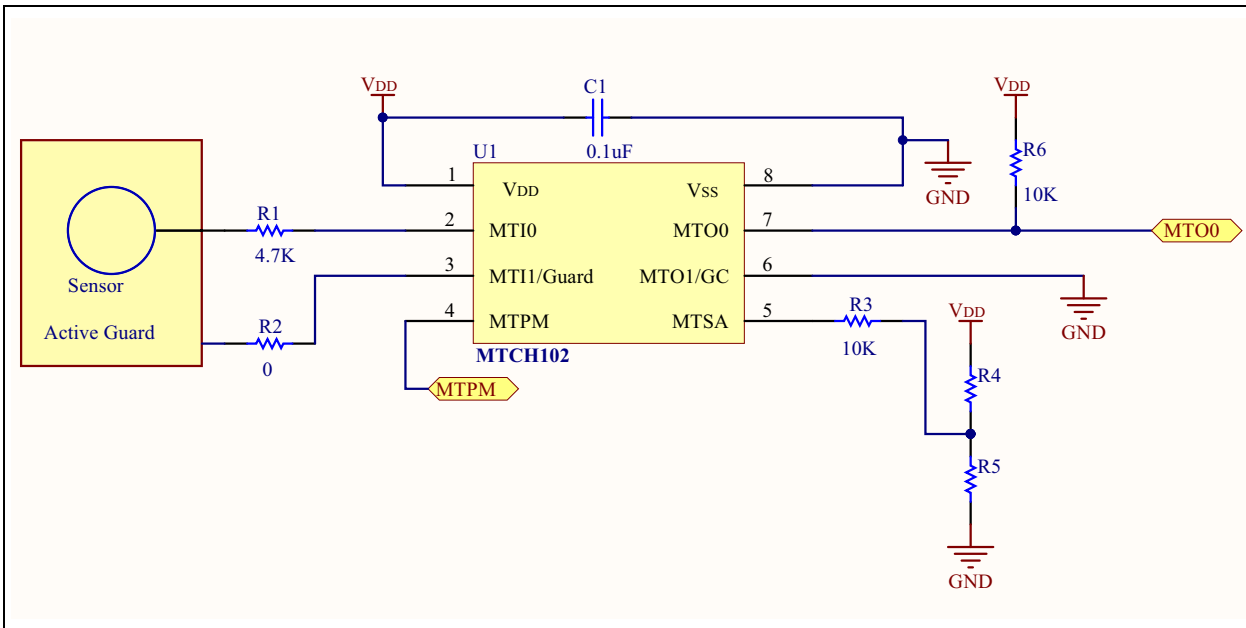

FIGURE 2-2: ONE SENSOR WITH ACTIVE GUARD CIRCUIT



3.0 SENSITIVITY ADJUSTMENT

The sensitivity of the sensor inputs determines how far it can respond to proximity or how much capacitance is required to activate a touch. The voltage on the MTCH102/5/8 MTSA pin will determine the sensitivity. VDD voltage will give the lowest sensitivity, while VSS voltage will give the highest. The device will sample the voltage on the MTSA pin after every 32nd scan, so it does not only support setting a fixed sensitivity by a resistor ladder, but it also allows adjusting the sensitivity dynamically while the device is running. A Digital-to-Analog Converter (DAC) controlled by the host or a hardware potentiometer can be used to adjust the sensitivity. Refer to the typical circuit in [Figure 3-1](#) to [Figure 3-4](#).

FIGURE 3-1: FIXED SENSITIVITY USING RESISTOR LADDER

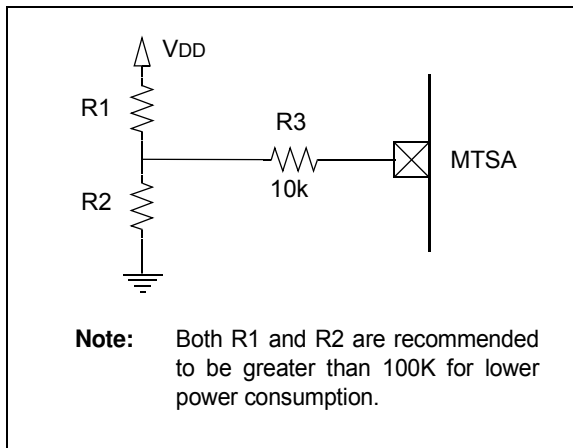

FIGURE 3-2: HARDWARE SENSITIVITY ADJUST USING POTENTIOMETER

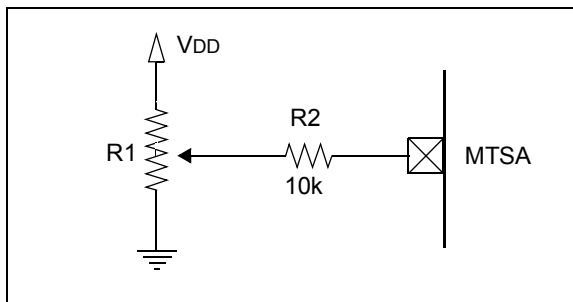

FIGURE 3-3: SENSITIVITY CONTROLLED BY HOST USING DAC

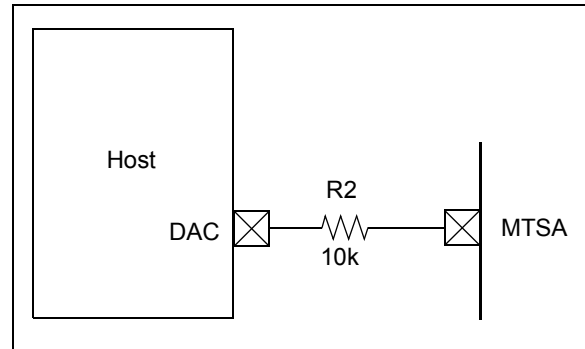
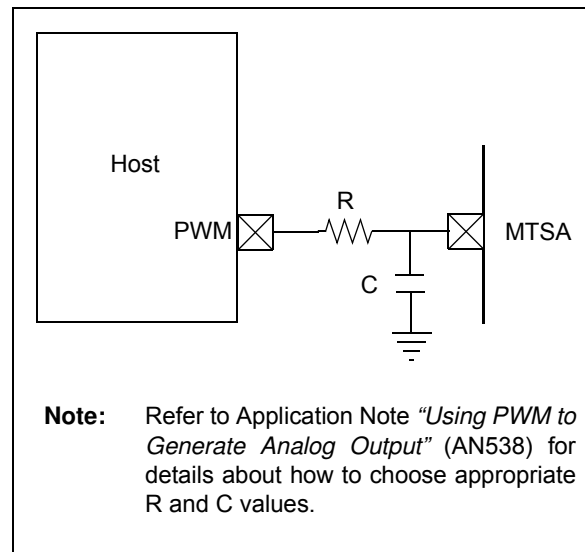

FIGURE 3-4: SENSITIVITY CONTROLLED BY HOST USING PWM



4.0 POWER MODE AND TIMEOUT RESET

The MTCH102/5/8 has three power mode options to meet the needs of various applications: Normal mode, Low-Power mode and Smart-Scheduling mode. The state of the MTPM pin determines the power mode.

4.1 Normal Mode

The device will run in Normal mode if the MTPM pin is connected to VDD. In this mode, the MTCH102/5/8 will scan continuously; so it will achieve the shortest response time among the three power modes, but also the power consumption is the highest.

4.2 Low-Power Mode

The device will run in Low-Power mode if the MTPM pin is connected to Vss. The device will go to Sleep for 256 ms after each round of sensor scans; so it will achieve the lowest power consumption, but it will have the longest response time among the three power modes, as shown in [Figure 4-1](#).

FIGURE 4-1: LOW-POWER MODE

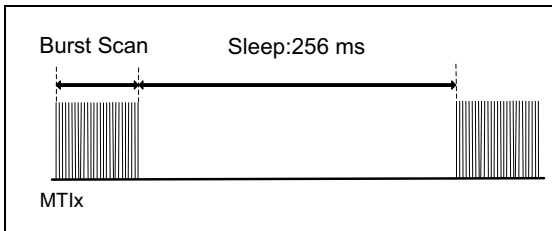

4.3 Smart-Scheduling Mode

The MTCH102/5/8 also implements a Smart-Scheduling mode that allows a host to set the exact sampling rate by pulsing the MTPM pin, as shown in [Figure 4-2](#). The minimum recognizable pulse width is 25 ns. If the MTPM pin is toggled during a scan cycle, the device will skip the next Sleep and immediately start a new set of scans.

FIGURE 4-2: SMART-SCHEDULING MODE

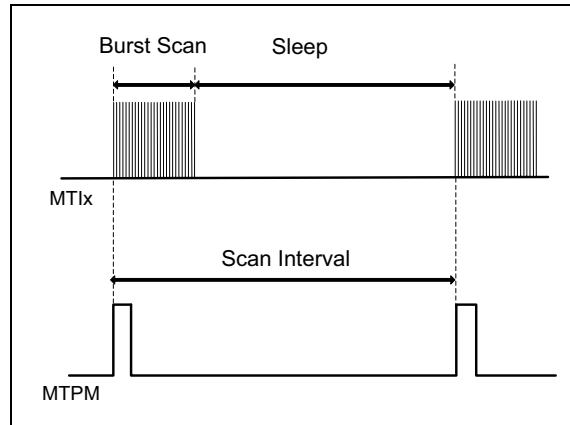

4.4 Timeout Reset

The device keeps track of the activated state duration for each MTIx input channel. The sensor state will be reset once the activated state duration exceeds the timeout duration, and the associated MTOx pin will release the line.

For the Normal and Low-Power modes, the timeout duration is 10 seconds. For the Smart-Scheduling mode, the timeout duration is 400 multiplied by the scan interval.

5.0 ELECTRICAL SPECIFICATIONS

Absolute Maximum Ratings^(†)

Ambient temperature under bias	-40°C to +125°C
Storage temperature	-65°C to +150°C
Voltage on pins with respect to V _{SS}	
on V _{DD} pin	-0.3V to +4.0V
on all other pins	-0.3V to (V _{DD} + 0.3V)
Total power dissipation ⁽¹⁾	800 mW
Maximum current	
out of V _{SS} pin	
-40°C ≤ T _A ≤ +85°C for industrial	85 mA
into V _{DD} pin	
-40°C ≤ T _A ≤ +85°C for industrial	80 mA
Clamp current, I _K (V _{PIN} < 0 or V _{PIN} > V _{DD})	± 20 mA
Maximum output current	
sunk by any I/O pin	25 mA
sourced by any I/O pin	25 mA

Note 1: Power dissipation is calculated as follows: $P_{DIS} = V_{DD} \times \{I_{DD} - \sum I_{OH}\} + \sum \{(V_{DD} - V_{OH}) \times I_{OH}\} + \sum (V_{OL} \times I_{OL})$.

† **NOTICE:** Stresses above those listed under “Absolute Maximum Ratings” may cause permanent damage to the device. This is a stress rating only and functional operation of the device at those or any other conditions above those indicated in the operation listings of this specification is not implied. Exposure to maximum rating conditions for extended periods may affect device reliability.

5.1 DC Characteristics: MTCH102/5/8

MTCH102/5/8			Standard Operating Conditions (unless otherwise stated)				
			Operating temperature -40°C ≤ T _A ≤ +85°C for industrial				
Param. No.	Sym.	Characteristic	Min.	Typ.†	Max.	Units	Conditions
D001	V _{DD}	Supply Voltage	2.05	—	3.6	V	
D002*	V _{DR}	RAM Data Retention Voltage ⁽¹⁾	1.5	—	—	V	Device in Sleep mode
	V _{POR} *	Power-on Reset Release Voltage	—	1.6	—	V	
	V _{PORR} *	Power-on Reset Rearm Voltage	—	0.8	—	V	Device in Sleep mode
D004*	ΔV _{DD}	V _{DD} Rise Rate to ensure internal Power-on Reset signal	0.05	—	—	V/ms	

* These parameters are characterized but not tested.

† Data in “Typ.” column is at 3.0V, 25°C unless otherwise stated. These parameters are for design guidance only and are not tested.

Note 1: This is the limit to which V_{DD} can be lowered in Sleep mode without losing RAM data.

FIGURE 5-1: MTCH10X FAMILY – POWER VS RESPONSE TIME

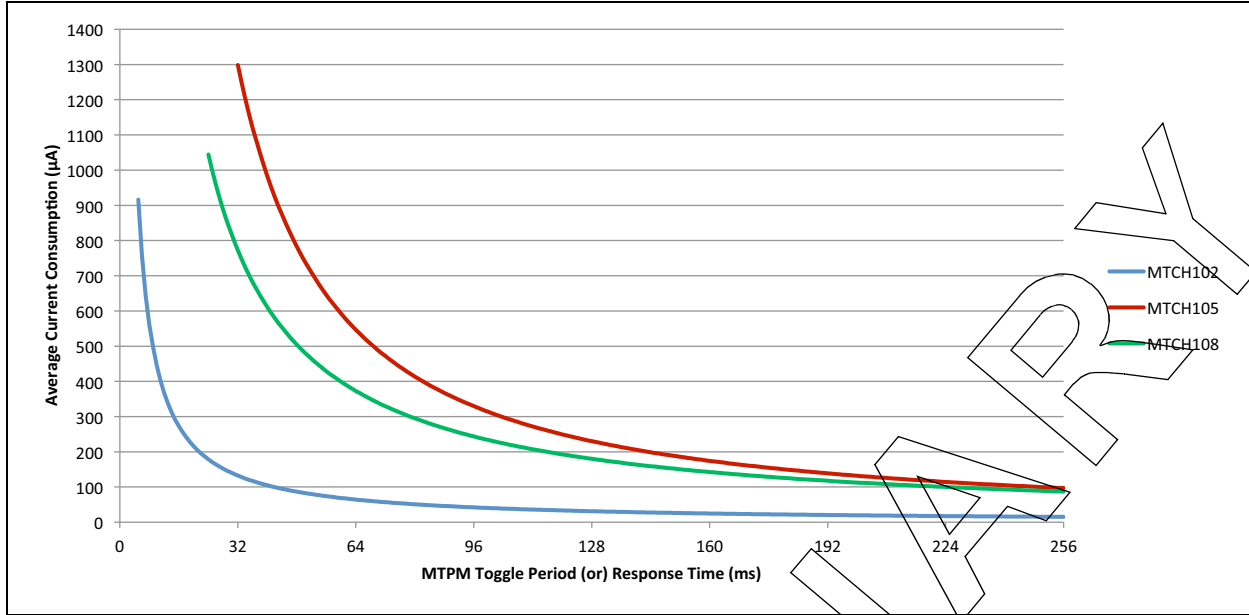
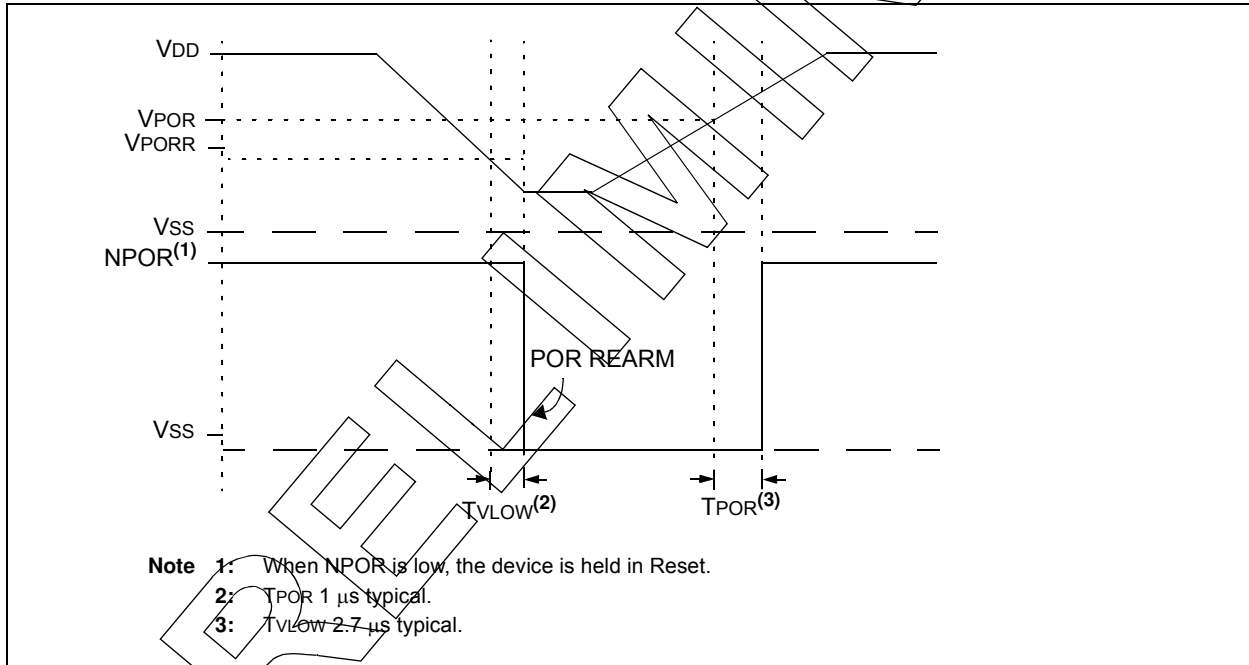

FIGURE 5-2: NPOR AND POR REARM WITH SLOW RISING VDD



5.2 DC Characteristics: MTCH102/5/8-I/E

DC CHARACTERISTICS		Standard Operating Conditions (unless otherwise stated) Operating temperature: $-40^{\circ}\text{C} \leq T_A \leq +85^{\circ}\text{C}$ for industrial					
Param. No.	Sym.	Characteristic	Min.	Typ.†	Max.	Units	Conditions
D030A	V _{IL}	Input Low Voltage					
		I/O PORT: with TTL buffer	—	—	0.15 V _{DD}	V	$1.8\text{V} \leq V_{DD} \leq 4.5\text{V}$
D040A	V _{IH}	Input High Voltage					
		I/O ports: with TTL buffer	$0.25 V_{DD} + 0.8$	—	—	V	$1.8\text{V} \leq V_{DD} \leq 4.5\text{V}$
D060	I _{IL}	Input Leakage Current⁽¹⁾					
		I/O ports	—	± 5	± 125	nA	$V_{SS} \leq V_{PIN} \leq V_{DD}$, Pin at high-impedance at 85°C to 125°C
		—	± 5	± 1000	nA		
D080	V _{OL}	Output Low Voltage⁽²⁾					
		I/O ports	—	—	0.6	V	$I_{OL} = 6\text{ mA}, V_{DD} = 3.3\text{V}$ $I_{OL} = 1.8\text{ mA}, V_{DD} = 1.8\text{V}$
D090	V _{OH}	Output High Voltage⁽²⁾					
		I/O ports	$V_{DD} - 0.7$	—	—	V	$I_{OH} = 3\text{ mA}, V_{DD} = 3.3\text{V}$ $I_{OH} = 1\text{ mA}, V_{DD} = 1.8\text{V}$
D101A*	C _{IO}	Capacitive Loading Specs on Output Pins					
		All I/O pins	—	—	50	pF	

* These parameters are characterized but not tested.

† Data in "Typ." column is at 3.0V, 25°C unless otherwise stated. These parameters are for design guidance only and are not tested.

Note 1: Negative current is defined as current sourced by the pin.

Note 2: Including OSC2 in CLKOUT mode.

FIGURE 5-3: BROWN-OUT RESET TIMING AND CHARACTERISTICS

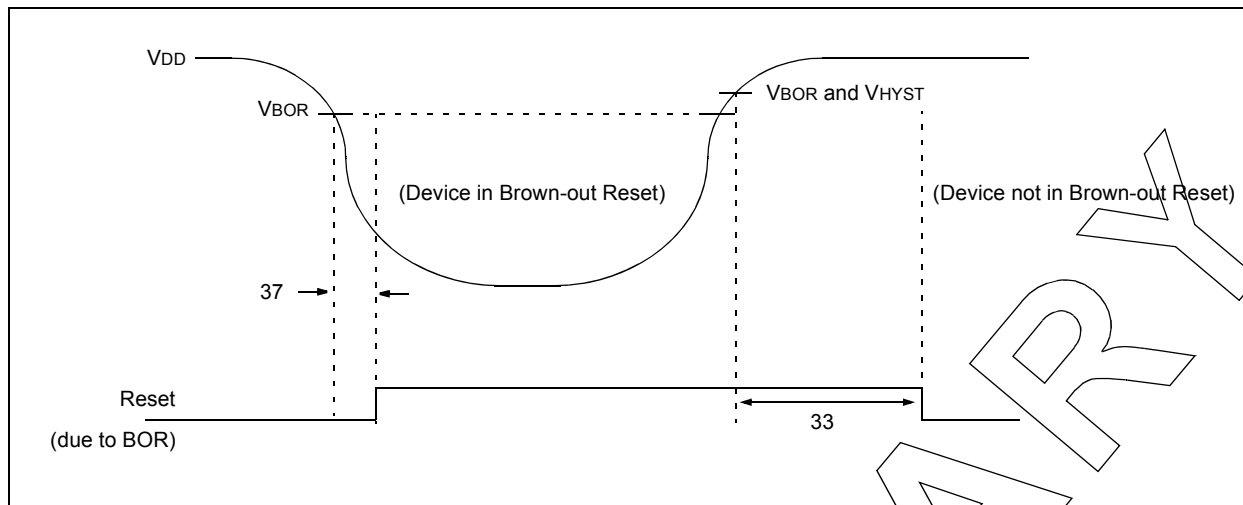

TABLE 5-1: OSCILLATOR START-UP TIMER, POWER-UP TIMER AND BROWN-OUT RESET PARAMETERS

Standard Operating Conditions (unless otherwise stated) Operating Temperature $-40^{\circ}\text{C} \leq T_A \leq +125^{\circ}\text{C}$							
Param. No.	Sym.	Characteristic	Min.	Typ.†	Max.	Units	Conditions
33*	TPWRT	Power-up Timer Period	40	65	140	ms	
34*	TIOZ	I/O High-impedance from RESET Low or Watchdog Timer Reset	—	—	20	μs	
35	VBOR	Brown-out Reset Voltage	1.80	1.9	2.05	V	BORV = 1.9V
37*	VHYST	Brown-out Reset Hysteresis	0	25	50	mV	-40°C to $+85^{\circ}\text{C}$
38*	TBORDC	Brown-out Reset DC Response Time	0	1	40	μs	$V_{DD} \leq V_{BOR}$

* These parameters are characterized but not tested.

† Data in "Typ." column is at 3.0V, 25°C unless otherwise stated. These parameters are for design guidance only and are not tested.

6.0 PACKAGING INFORMATION

6.1 Package Marking Information

8-Lead UDFN (2x3x0.5 mm)



Example

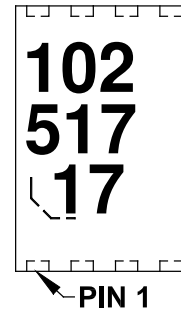

8-Lead MSOP (3x3 mm)

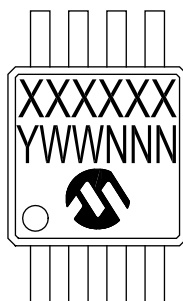

Example



14-Lead TSSOP (4.4 mm)

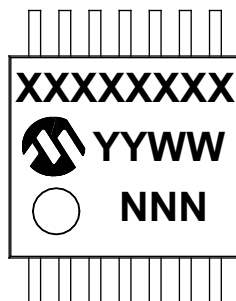

Example

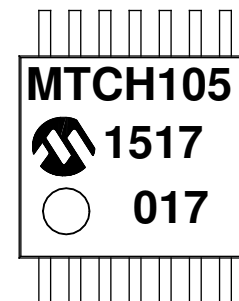

Legend:	XX...X	Customer-specific information
	Y	Year code (last digit of calendar year)
	YY	Year code (last 2 digits of calendar year)
	WW	Week code (week of January 1 is week '01')
	NNN	Alphanumeric traceability code
	(e3)	Pb-free JEDEC® designator for Matte Tin (Sn)
	*	This package is Pb-free. The Pb-free JEDEC® designator (e3) can be found on the outer packaging for this package.

Note: In the event the full Microchip part number cannot be marked on one line, it will be carried over to the next line, thus limiting the number of available characters for customer-specific information.

MTCH102/5/8

Package Marking Information (Continued)

16-Lead QFN (4x4x0.9 mm)

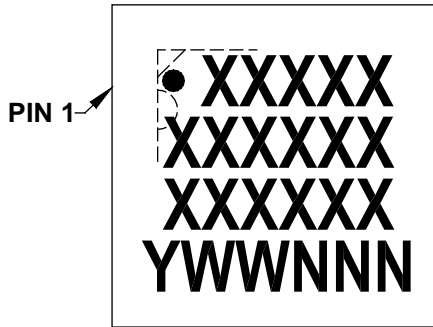

Example

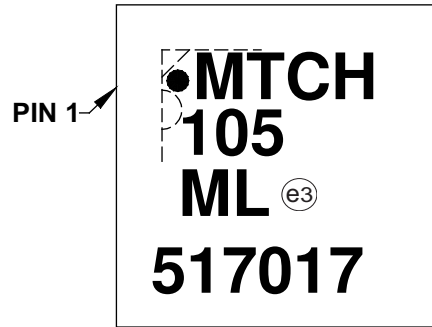

20-Lead SSOP (5.30 mm)

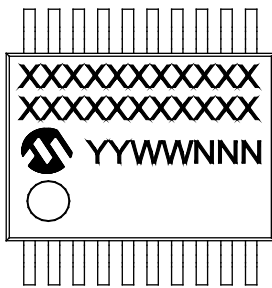

Example

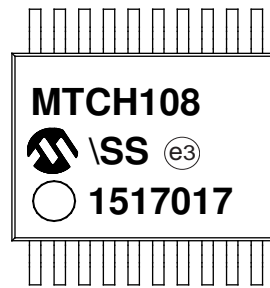

20-Lead UQFN (4x4x0.9 mm)

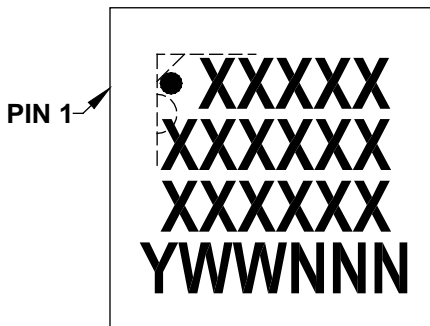

Example

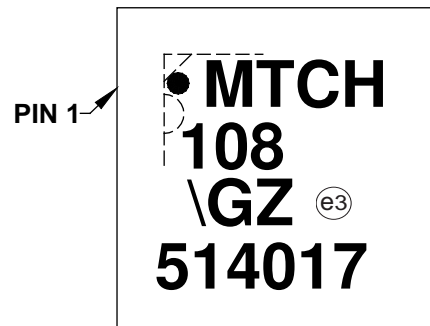

Legend:	XX...X	Customer-specific information
	Y	Year code (last digit of calendar year)
	YY	Year code (last 2 digits of calendar year)
	WW	Week code (week of January 1 is week '01')
	NNN	Alphanumeric traceability code
	(e3)	Pb-free JEDEC® designator for Matte Tin (Sn)
	*	This package is Pb-free. The Pb-free JEDEC® designator (e3) can be found on the outer packaging for this package.
Note:	In the event the full Microchip part number cannot be marked on one line, it will be carried over to the next line, thus limiting the number of available characters for customer-specific information.	

6.2 Package Details

The following sections give the technical details of the packages.

8-Lead Plastic Dual Flat, No Lead Package (MU) – 2x3x0.5 mm Body [UDFN]

Note: For the most current package drawings, please see the Microchip Packaging Specification located at <http://www.microchip.com/packaging>

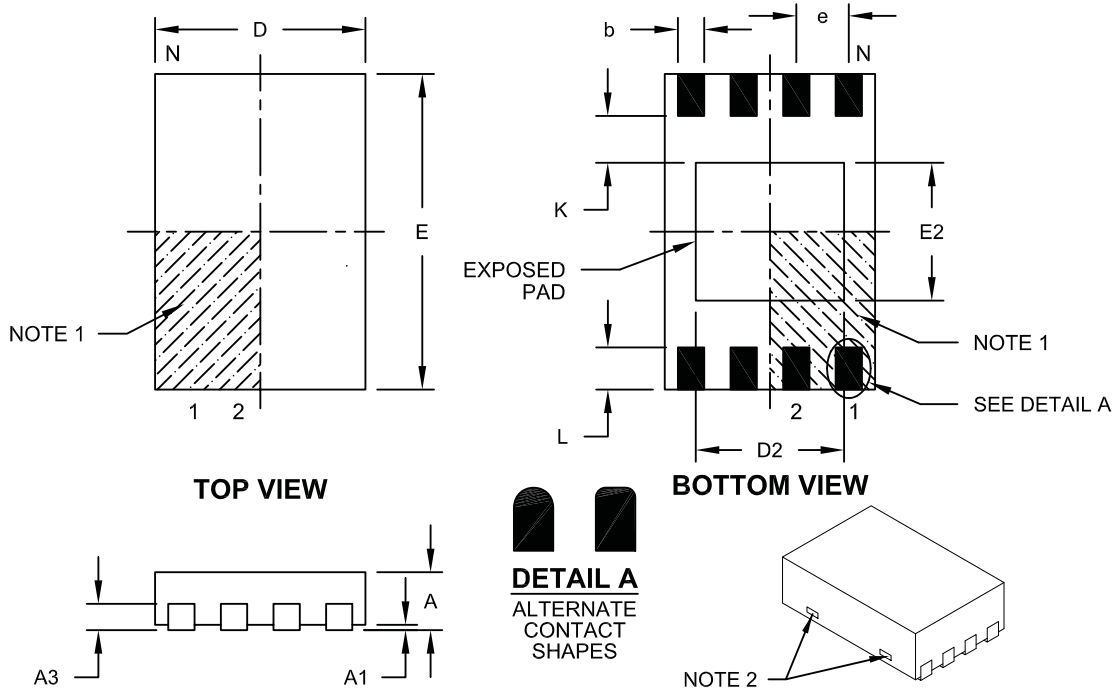

		Units	MILLIMETERS		
Dimension Limits			MIN	NOM	MAX
Number of Pins	N		8		
Pitch	e		0.50 BSC		
Overall Height	A	0.45		0.50	0.55
Standoff	A1				0.07
Contact Thickness	A3		0.127 REF		
Overall Length	D	1.95	2.00		2.05
Overall Width	E	2.95	3.00		3.05
Exposed Pad Length	D2	1.30	1.40		1.50
Exposed Pad Width	E2	1.20	1.30		1.40
Contact Width	b	0.20	0.25		0.30
Contact Length	L	0.25	0.30		0.35
Contact-to-Exposed Pad	K		0.55 REF		

Notes:

1. Pin 1 visual index feature may vary, but must be located within the hatched area.
2. Package may have one or more exposed tie bars at ends.
3. Package is saw singulated
4. Dimensioning and tolerancing per ASME Y14.5M

BSC: Basic Dimension. Theoretically exact value shown without tolerances.

REF: Reference Dimension, usually without tolerance, for information purposes only.

Microchip Technology Drawing No. C04-136B

MTCH102/5/8

8-Lead Plastic Dual Flat, No Lead Package (MU) – 2x3x0.5 mm Body [UDFN]

Note: For the most current package drawings, please see the Microchip Packaging Specification located at <http://www.microchip.com/packaging>

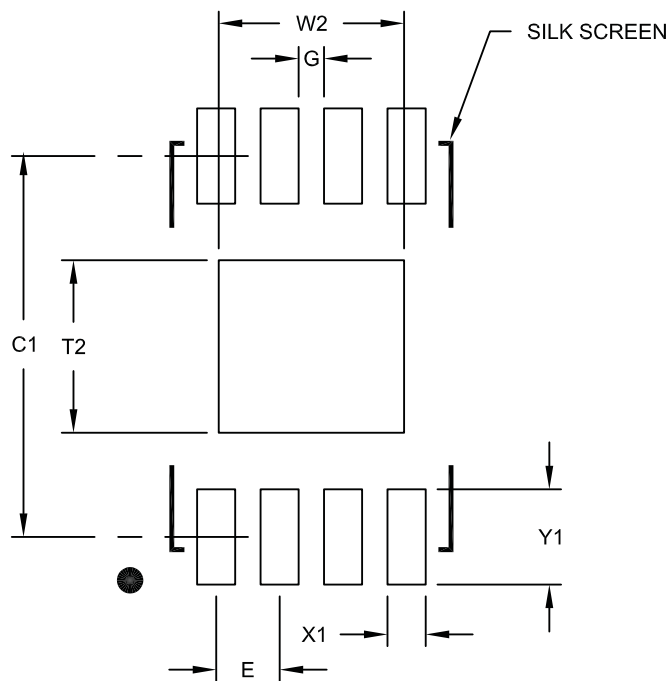

RECOMMENDED LAND PATTERN

Dimension Limits	Units	MILLIMETERS		
		MIN	NOM	MAX
Contact Pitch	E	0.50 BSC		
Optional Center Pad Width	W2			1.46
Optional Center Pad Length	T2			1.36
Contact Pad Spacing	C1		3.00	
Contact Pad Width (X8)	X1			0.30
Contact Pad Length (X8)	Y1			0.75
Distance Between Pads	G	0.20		

Notes:

1. Dimensioning and tolerancing per ASME Y14.5M

BSC: Basic Dimension. Theoretically exact value shown without tolerances.

Microchip Technology Drawing No. C04-2136A

8-Lead Plastic Micro Small Outline Package (MS) [MSOP]

Note: For the most current package drawings, please see the Microchip Packaging Specification located at <http://www.microchip.com/packaging>

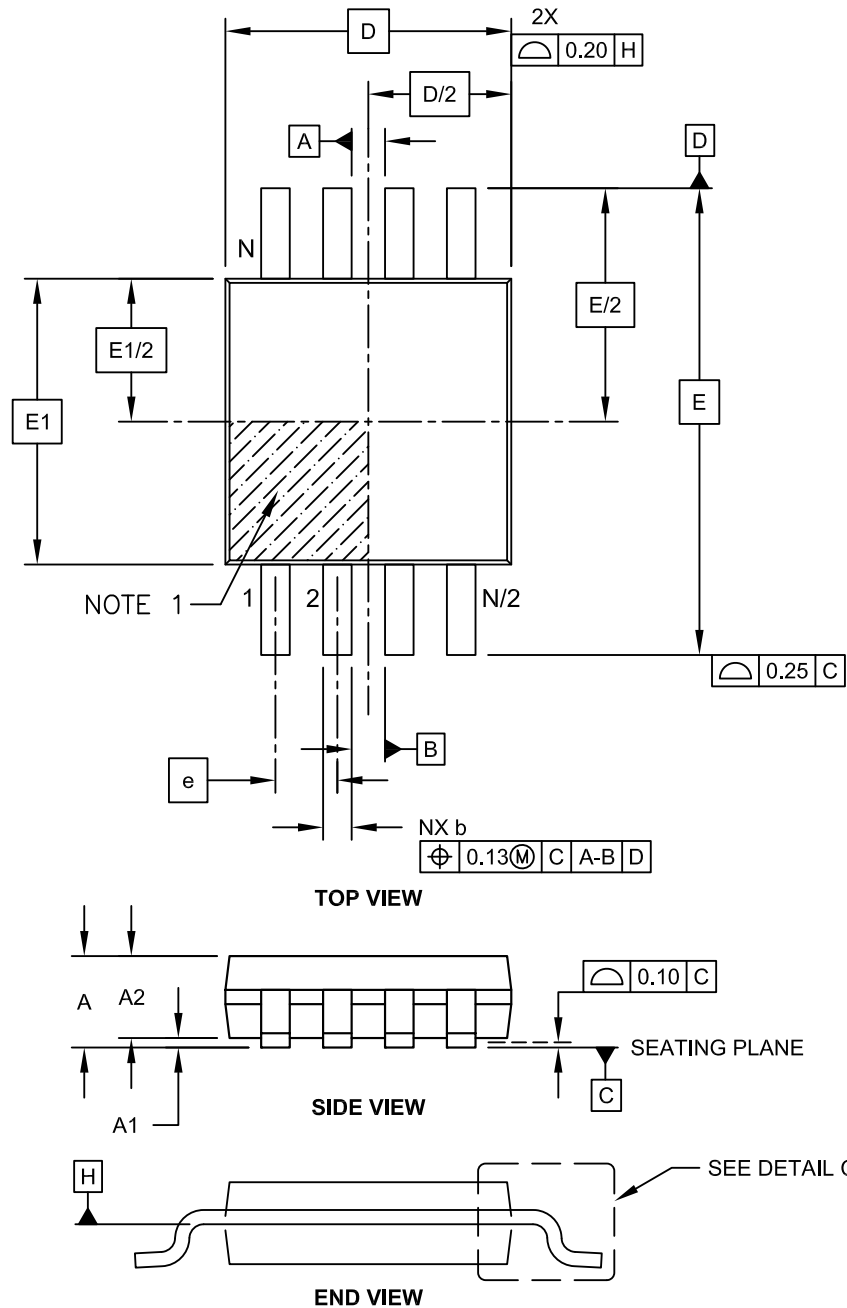

Microchip Technology Drawing C04-111C Sheet 1 of 2

MTCH102/5/8

8-Lead Plastic Micro Small Outline Package (MS) [MSOP]

Note: For the most current package drawings, please see the Microchip Packaging Specification located at <http://www.microchip.com/packaging>

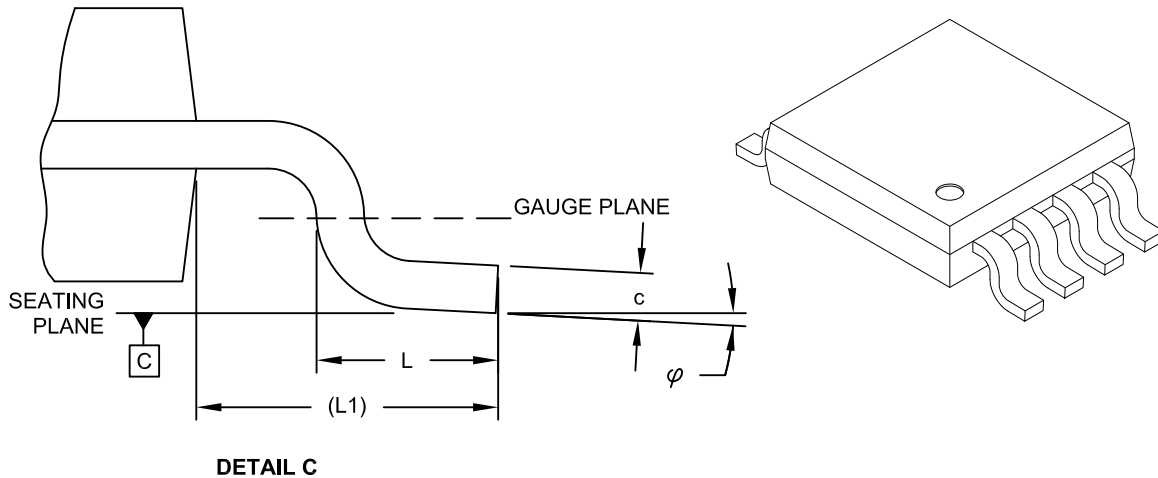

Dimension Limits	Units	MILLIMETERS		
		MIN	NOM	MAX
Number of Pins	N	8		
Pitch	e	0.65 BSC		
Overall Height	A	-	-	1.10
Molded Package Thickness	A2	0.75	0.85	0.95
Standoff	A1	0.00	-	0.15
Overall Width	E	4.90 BSC		
Molded Package Width	E1	3.00 BSC		
Overall Length	D	3.00 BSC		
Foot Length	L	0.40	0.60	0.80
Footprint	L1	0.95 REF		
Foot Angle	φ	0°	-	8°
Lead Thickness	c	0.08	-	0.23
Lead Width	b	0.22	-	0.40

Notes:

- Pin 1 visual index feature may vary, but must be located within the hatched area.
- Dimensions D and E1 do not include mold flash or protrusions. Mold flash or protrusions shall not exceed 0.15mm per side.
- Dimensioning and tolerancing per ASME Y14.5M.

BSC: Basic Dimension. Theoretically exact value shown without tolerances.
REF: Reference Dimension, usually without tolerance, for information purposes only.

Microchip Technology Drawing C04-111C Sheet 2 of 2

8-Lead Plastic Micro Small Outline Package (MS) [MSOP]

Note: For the most current package drawings, please see the Microchip Packaging Specification located at <http://www.microchip.com/packaging>

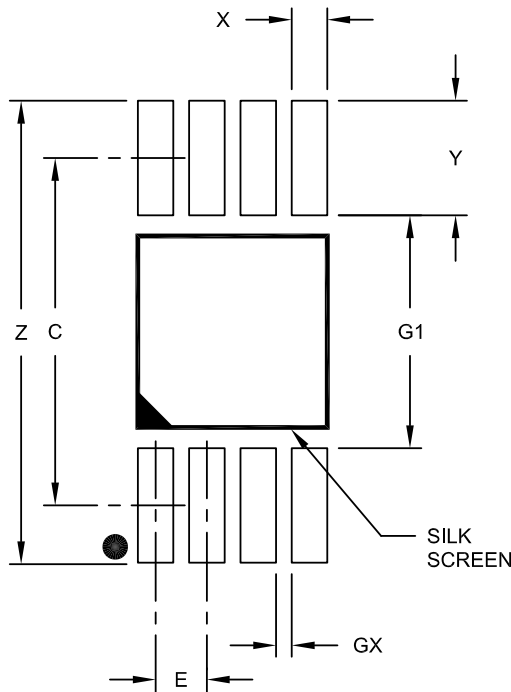

RECOMMENDED LAND PATTERN

Dimension Limits	Units	MILLIMETERS		
		MIN	NOM	MAX
Contact Pitch	E	0.65 BSC		
Contact Pad Spacing	C		4.40	
Overall Width	Z			5.85
Contact Pad Width (X8)	X1			0.45
Contact Pad Length (X8)	Y1			1.45
Distance Between Pads	G1	2.95		
Distance Between Pads	GX	0.20		

Notes:

1. Dimensioning and tolerancing per ASME Y14.5M

BSC: Basic Dimension, Theoretically exact value shown without tolerances.

Microchip Technology Drawing No. C04-2111A

MTCH102/5/8

14-Lead Plastic Thin Shrink Small Outline (ST) - 4.4 mm Body [TSSOP]

Note: For the most current package drawings, please see the Microchip Packaging Specification located at <http://www.microchip.com/packaging>

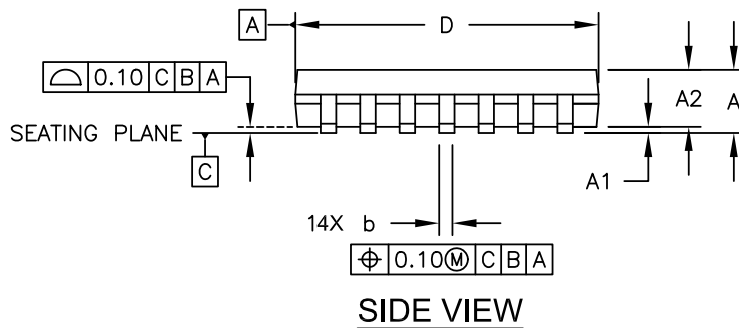
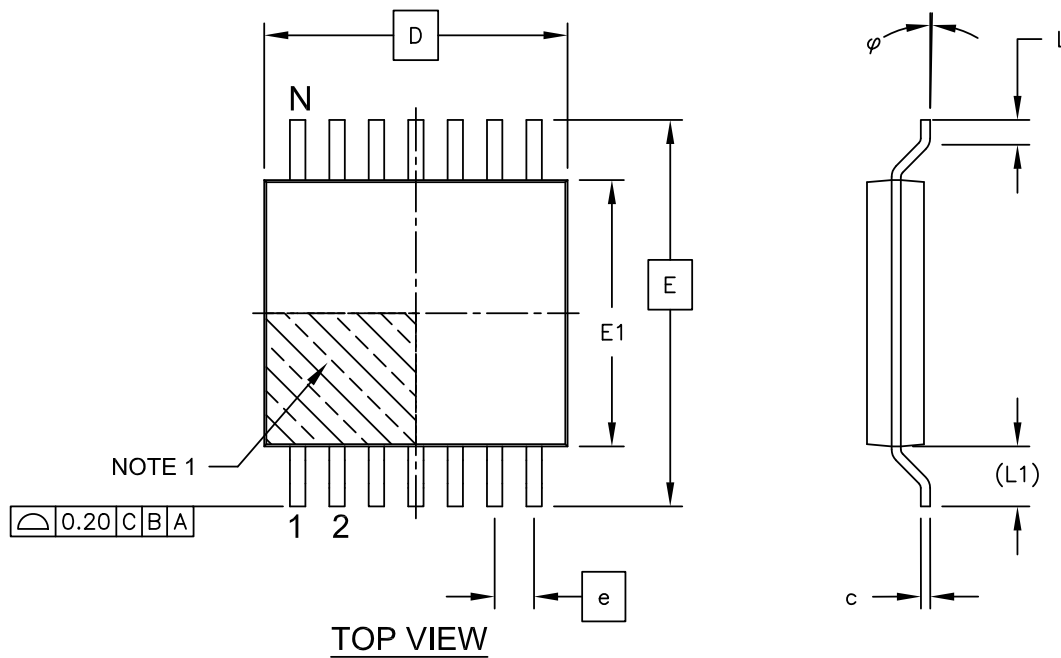

Microchip Technology Drawing C04-087C Sheet 1 of 2

14-Lead Plastic Thin Shrink Small Outline (ST) - 4.4 mm Body [TSSOP]

Note: For the most current package drawings, please see the Microchip Packaging Specification located at <http://www.microchip.com/packaging>

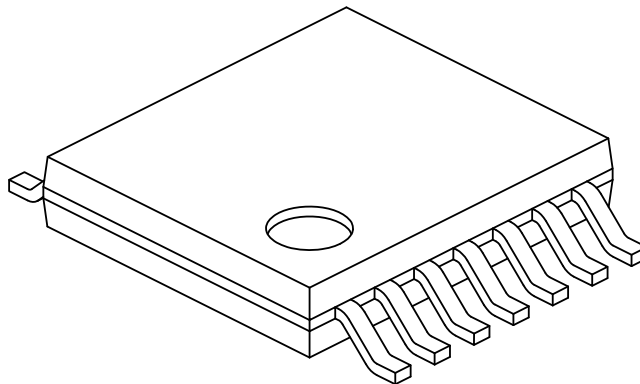

Dimension Limits	Units	MILLIMETERS		
		MIN	NOM	MAX
Number of Pins	N	14		
Pitch	e	0.65 BSC		
Overall Height	A	-	-	1.20
Molded Package Thickness	A2	0.80	1.00	1.05
Standoff	A1	0.05	-	0.15
Overall Width	E	6.40 BSC		
Molded Package Width	E1	4.30	4.40	4.50
Molded Package Length	D	4.90	5.00	5.10
Foot Length	L	0.45	0.60	0.75
Footprint	(L1)	1.00 REF		
Foot Angle	φ	0°	-	8°
Lead Thickness	c	0.09	-	0.20
Lead Width	b	0.19	-	0.30

Notes:

1. Pin 1 visual index feature may vary, but must be located within the hatched area.
2. Dimensions D and E1 do not include mold flash or protrusions. Mold flash or protrusions shall not exceed 0.15mm per side.
3. Dimensioning and tolerancing per ASME Y14.5M
 - BSC: Basic Dimension. Theoretically exact value shown without tolerances.
 - REF: Reference Dimension, usually without tolerance, for information purposes only.

Microchip Technology Drawing No. C04-087C Sheet 2 of 2

14-Lead Plastic Thin Shrink Small Outline (ST) - 4.4 mm Body [TSSOP]

Note: For the most current package drawings, please see the Microchip Packaging Specification located at <http://www.microchip.com/packaging>

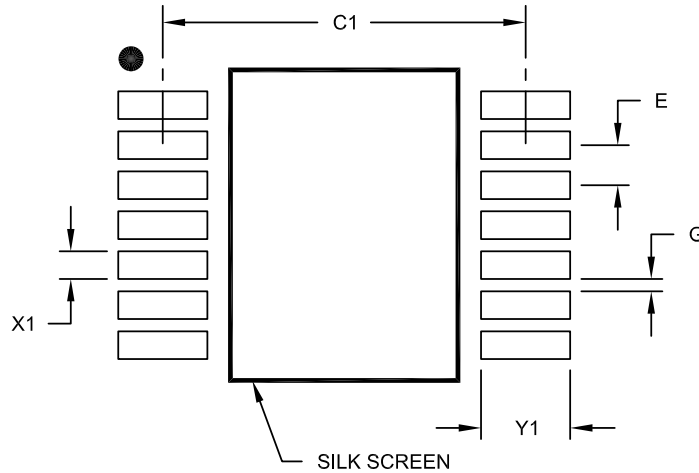

RECOMMENDED LAND PATTERN

Dimension Limits	Units	MILLIMETERS		
		MIN	NOM	MAX
Contact Pitch	E	0.65 BSC		
Contact Pad Spacing	C1		5.90	
Contact Pad Width (X14)	X1			0.45
Contact Pad Length (X14)	Y1			1.45
Distance Between Pads	G	0.20		

Notes:

1. Dimensioning and tolerancing per ASME Y14.5M

BSC: Basic Dimension. Theoretically exact value shown without tolerances.

Microchip Technology Drawing No. C04-2087A

16-Lead Plastic Quad Flat, No Lead Package (ML) - 4x4x0.9mm Body [QFN]

Note: For the most current package drawings, please see the Microchip Packaging Specification located at <http://www.microchip.com/packaging>

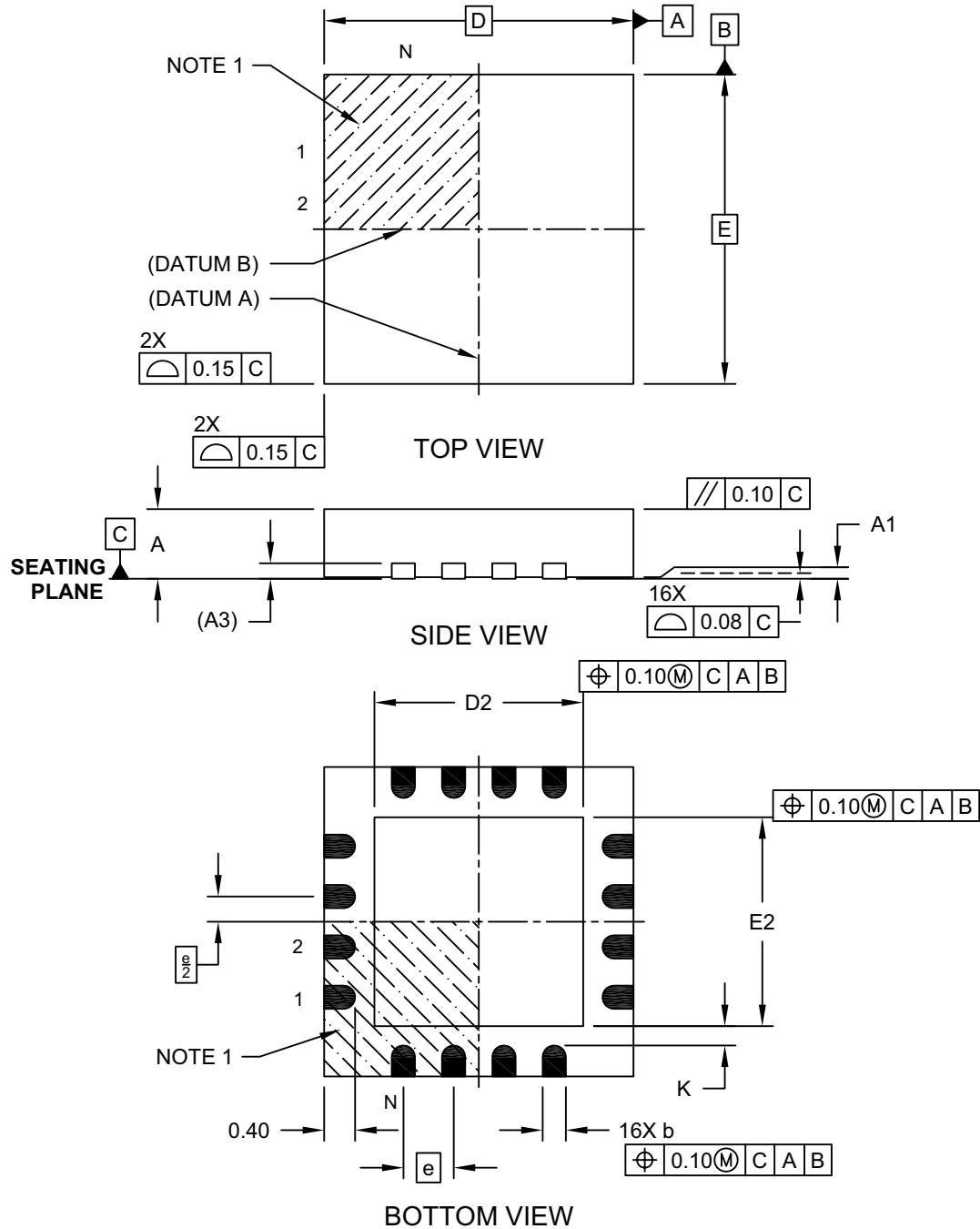

Microchip Technology Drawing C04-127D Sheet 1 of 2