



Chipsmall Limited consists of a professional team with an average of over 10 year of expertise in the distribution of electronic components. Based in Hongkong, we have already established firm and mutual-benefit business relationships with customers from,Europe,America and south Asia,supplying obsolete and hard-to-find components to meet their specific needs.

With the principle of “Quality Parts,Customers Priority,Honest Operation,and Considerate Service”,our business mainly focus on the distribution of electronic components. Line cards we deal with include Microchip,ALPS,ROHM,Xilinx,Pulse,ON,Everlight and Freescale. Main products comprise IC,Modules,Potentiometer,IC Socket,Relay,Connector.Our parts cover such applications as commercial,industrial, and automotives areas.

We are looking forward to setting up business relationship with you and hope to provide you with the best service and solution. Let us make a better world for our industry!



Contact us

Tel: +86-755-8981 8866 Fax: +86-755-8427 6832

Email & Skype: info@chipsmall.com Web: www.chipsmall.com

Address: A1208, Overseas Decoration Building, #122 Zhenhua RD., Futian, Shenzhen, China



Materials			
No.	Component name	Base material	Finish
1	Housing	High Temp., UL 94V-0, green	
2	End terminal	silver clad copper alloy	5 microinches min. gold
3	Center terminal	copper alloy	5 microinches min. gold
4	Rocker contact	silver clad copper alloy	5 microinches min. gold
5	Actuator	Phenol resin, UL94 HB, black	
6	Plunger	stainless steel	
7	Spring	music wire	
8	Toggle	brass	chrome or Nickel
9	Retainer	Polyamide, UL94 HB, black	
10	Frame	cold rolled steel	zinc or Nickel
11	Bushing	brass	100 microinches min. nickel over 10 microinches min. copper
12	Mounting nuts (2)	brass	200 microinches min. bright nickel
13	Locating ring	cold rolled steel	zinc or Nickel
14	Internal tooth lockwasher	steel	zinc or Nickel

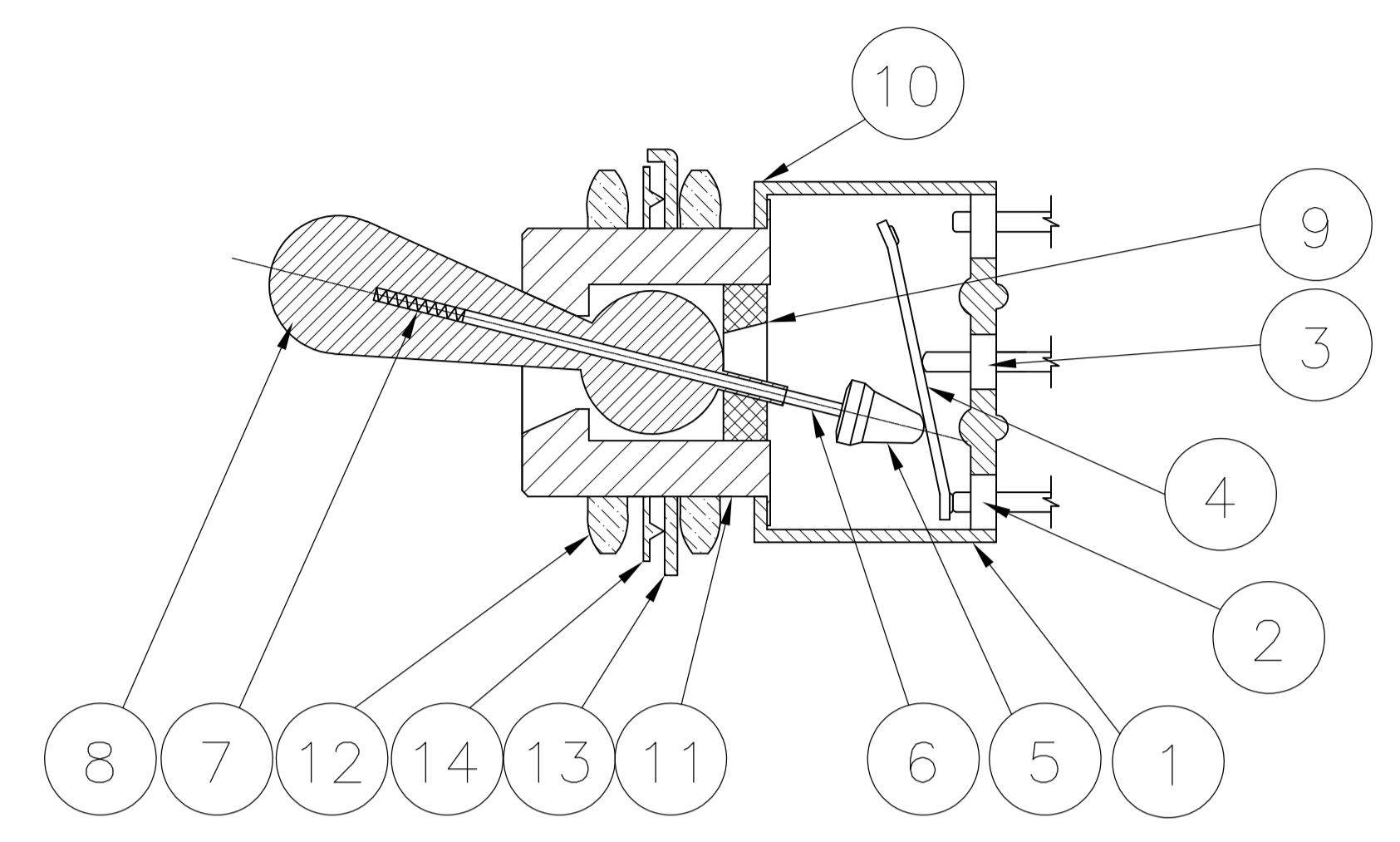

NOT TO SCALE

Specifications—see note 3				
Current rating UL & CSA	6A @ 125 VAC (resistive)			
	3A @ 250 VAC (resistive)			
	4A @ 28 VDC (resistive)			
Termination resistance	20 milliohms max @ 2-4 VDC, 1A			
Insulation resistance	1,000 megohms min.			
Withstanding voltage	1,000 VAC			
Travel	24 +/-6 degrees			
Actuation force	.05 to 1.5 kgf			
Operating temperature	-20C to +85C			
Storage temperature	-40C to +85C			
Contact timing	break before make			
Terminal seal	epoxy or insert molded			
Durability	Parameter	2 Position	3 Position	Momentary
	mechanical (no load)	150,000	100,000	80,000
	250 VAC (3A resistive)	80,000	60,000	60,000
	125 VAC (6A resistive)	80,000	60,000	60,000
	28 VDC (4A resistive)	60,000	50,000	40,000

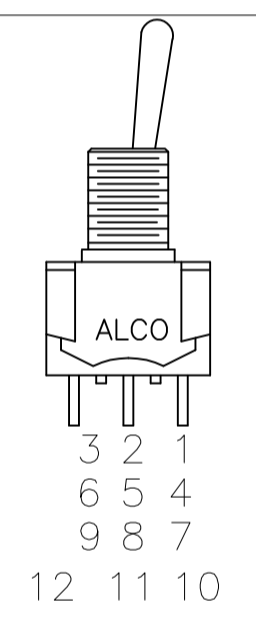
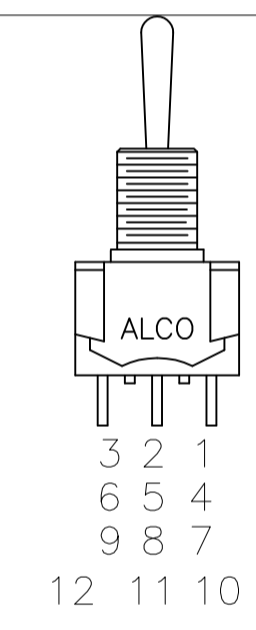
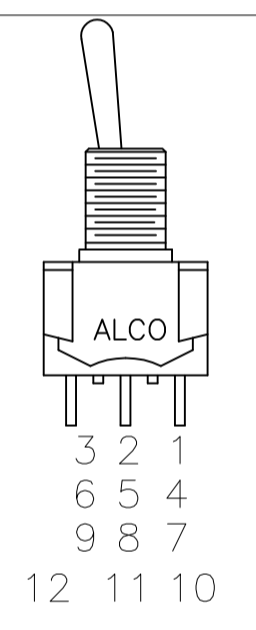
Part Number	Alco Model	Poles	Throws	Function	Terminal	A				Comments
3-1437559-2	MTG406P	4	2	ON OFF ON	Wire lug	.453	2-3, 5-6, 8-9, 11-12	Off	2-1, 5-4, 8-7, 11-10	
3-1437559-3	MTG426N	4	2	ON ON	Wire lug	.685	2-3, 5-6, 8-9, 11-12	---	2-1, 5-4, 8-7, 11-10	
3-1437559-1	MTG406N	4	2	ON ON	Wire lug	.453	2-3, 5-6, 8-9, 11-12	---	2-1, 5-4, 8-7, 11-10	
2-1437559-9	MTG306E	3	2	ON OFF ON	Wire lug	.453	2-3, 5-6, 8-9	Off	2-1, 5-4, 8-7	
3-1437559-0	MTG326D	3	2	ON ON	Wire lug	.685	2-3, 5-6, 8-9	---	2-1, 5-4, 8-7	
2-1437559-8	MTG306D	3	2	ON ON	Wire lug	.453	2-3, 5-6, 8-9	---	2-1, 5-4, 8-7	
2-1437559-7	MTG226PA	1	3	ON ON ON	Wire lug	.685	5-6	5-3	5-1	note 6
2-1437559-6	MTG226P	2	2	ON OFF ON	Wire lug	.685	2-3, 5-6	Off	2-1, 5-4	
2-1437559-5	MTG226N	2	2	ON ON	Wire lug	.685	2-3, 5-6	---	2-1, 5-4	
2-1437559-4	MTG206T	2	2	ON OFF(ON)	Wire lug	.453	2-3, 5-6	Off	2-1, 5-4	
2-1437559-3	MTG206S	2	2	(ON) OFF (ON)	Wire lug	.453	2-3, 5-6	Off	2-1, 5-4	
2-1437559-2	MTG206R	2	2	ON (ON)	Wire lug	.453	2-3, 5-6	---	2-1, 5-4	
2-1437559-1	MTG206PA	1	3	ON ON ON	Wire lug	.453	5-6	5-3	5-1	note 6
2-1437559-0	MTG206P	2	2	ON OFF ON	Wire lug	.453	2-3, 5-6	Off	2-1, 5-4	
1-1437559-9	MTG206NPC	2	2	ON ON	PC	.453	2-3, 5-6	---	2-1, 5-4	
1-1437559-8	MTG206N	2	2	ON ON	Wire lug	.453	2-3, 5-6	---	2-1, 5-4	
1-1437559-0	MTG126G	1	2	(ON) OFF (ON)	Wire lug	.685	2-3	Off	2-1	
1-1437559-7	MTG126E	1	2	ON OFF ON	Wire lug	.685	2-3	Off	2-1	
1-1437559-6	MTG126D	1	2	ON ON	Wire lug	.685	2-3	---	2-1	
1-1437559-5	MTG106H	1	2	ON OFF(ON)	Wire lug	.453	2-3	Off	2-1	
1-1437559-4	MTG106G	1	2	(ON) OFF (ON)	Wire lug	.453	2-3	Off	2-1	
1-1437559-3	MTG106F	1	2	ON (ON)	Wire lug	.453	2-3	---	2-1	
1-1437559-2	MTG106E	1	2	ON OFF ON	Wire lug	.453	2-3	Off	2-1	
1-1437559-1	MTG106D	1	2	ON ON	Wire lug	.453	2-3	---	2-1	

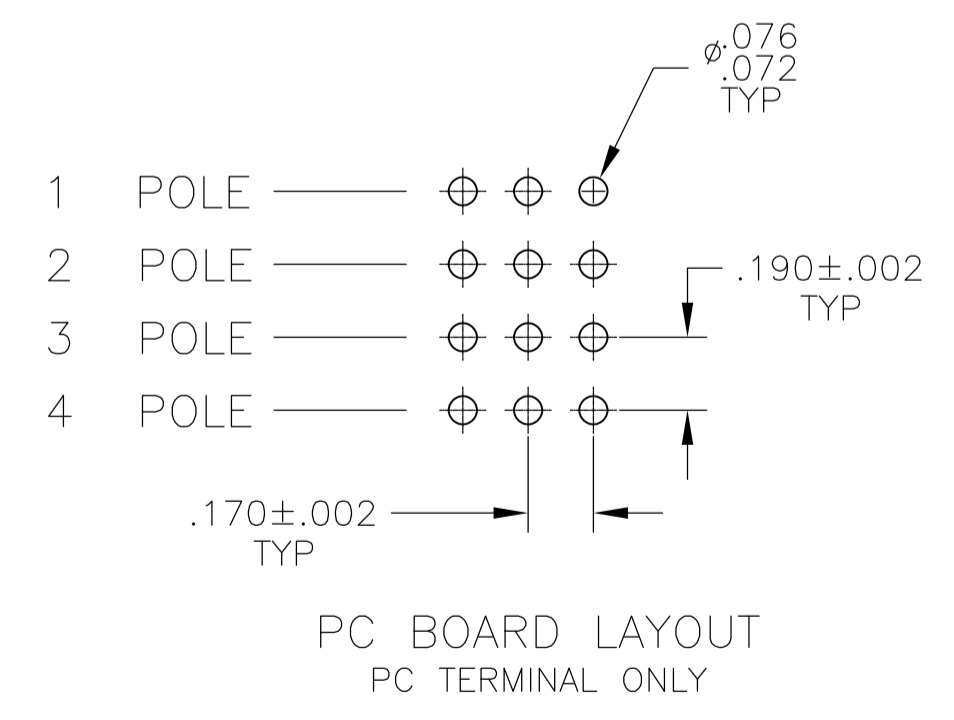
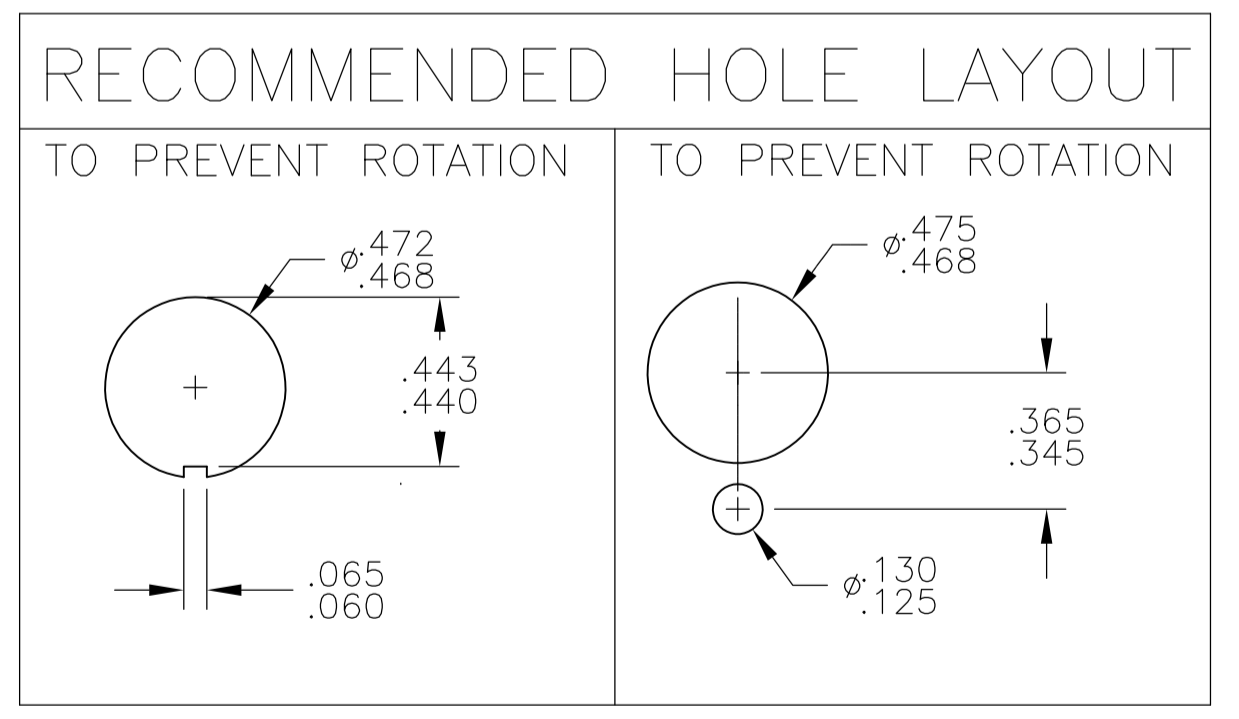

- NOTES:
- TERMINAL NUMBERS ARE FOR REFERENCE ONLY AND DO NOT APPEAR ON THE SWITCHES.
 - EACH SWITCH SUPPLIED WITH THE FOLLOWING MOUNTING HARDWARE:
 - (2) 15/32-32 UNS-2B HEX NUTS
 - (1) INTERNAL TOOTH LOCKWASHER
 - (1) LOCATING RING

- WIRE LUG CONTACTS WILL ACCEPT 2 #20 AWG SOLID OR STRANDED WIRES.
- CUSTOMER INSTALLED EXTERNAL JUMPER BETWEEN TERMINALS 2 AND 4 REQUIRED FOR 1 POLE 3 THROW FUNCTION.

 OBSOLETE

THIS DRAWING IS A CONTROLLED DOCUMENT.

DIMENSIONS: INCHES	TOLERANCES UNLESS OTHERWISE SPECIFIED:	0 PLC ± .005	1 PLC ± .005	2 PLC ± .005	3 PLC ± .005	4 PLC ± .005
MATERIAL	FINISH	WEIGHT	SIZE	CAGE CODE	DRAWING NO.	RESTRICTED TO
			A1	00779	1-1437559-1	

STE TE Connectivity

TOGGLE SWITCH, MTG SERIES VERTICAL MOUNT

CUSTOMER DRAWING SCALE 2:1 SHEET 1 OF 3 REV D4

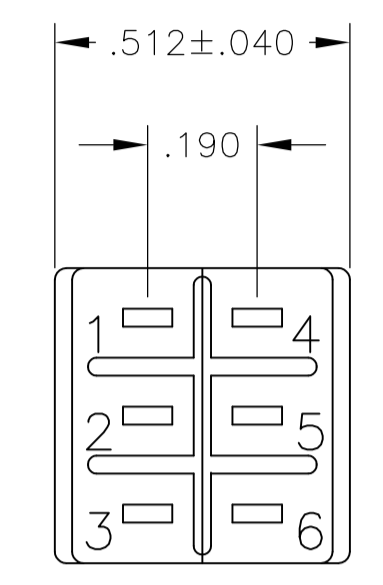
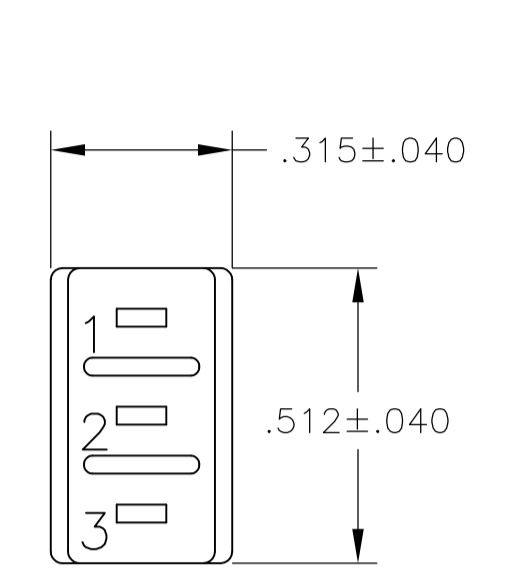
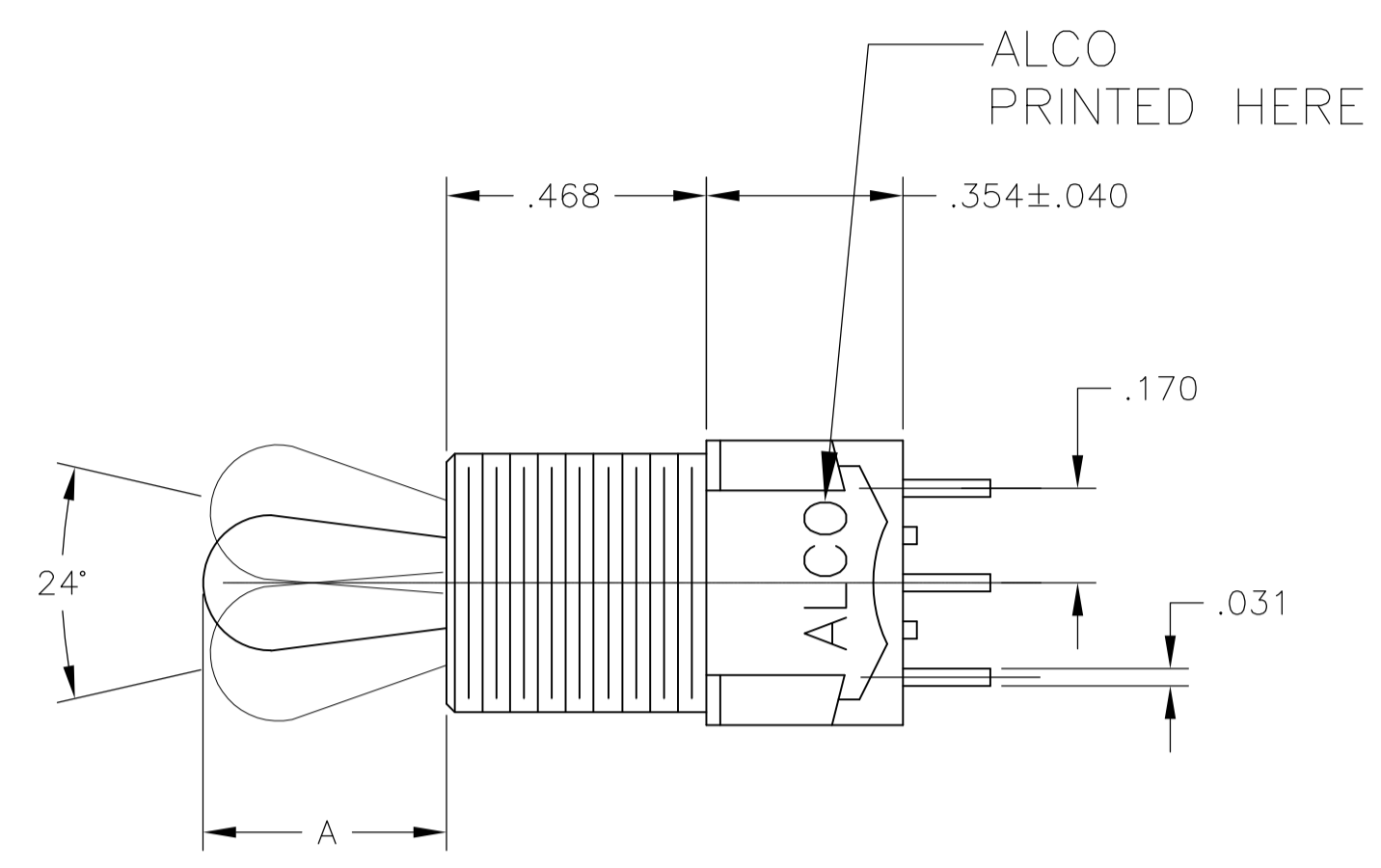

MTG-106

MTG-206

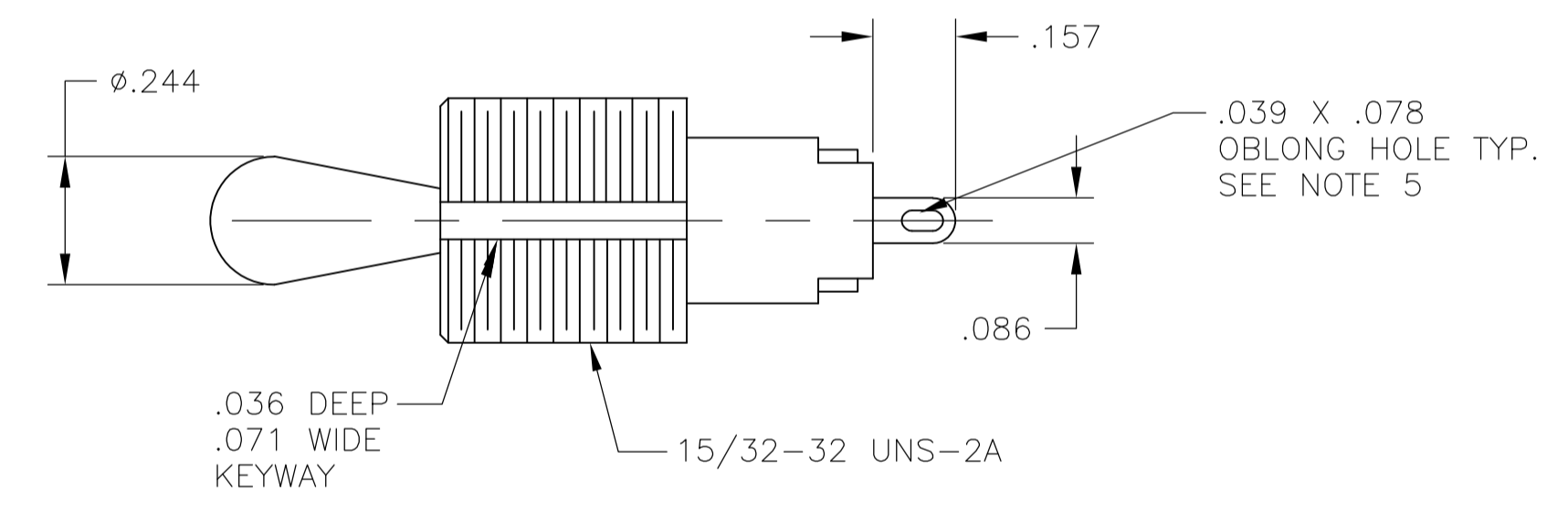

WIRE LUG TERMINAL

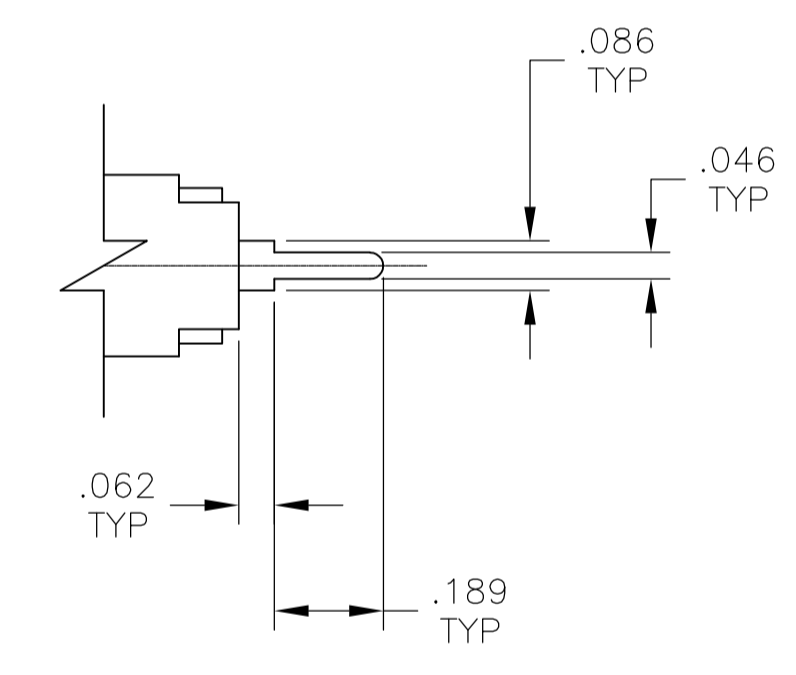

PC TERMINAL

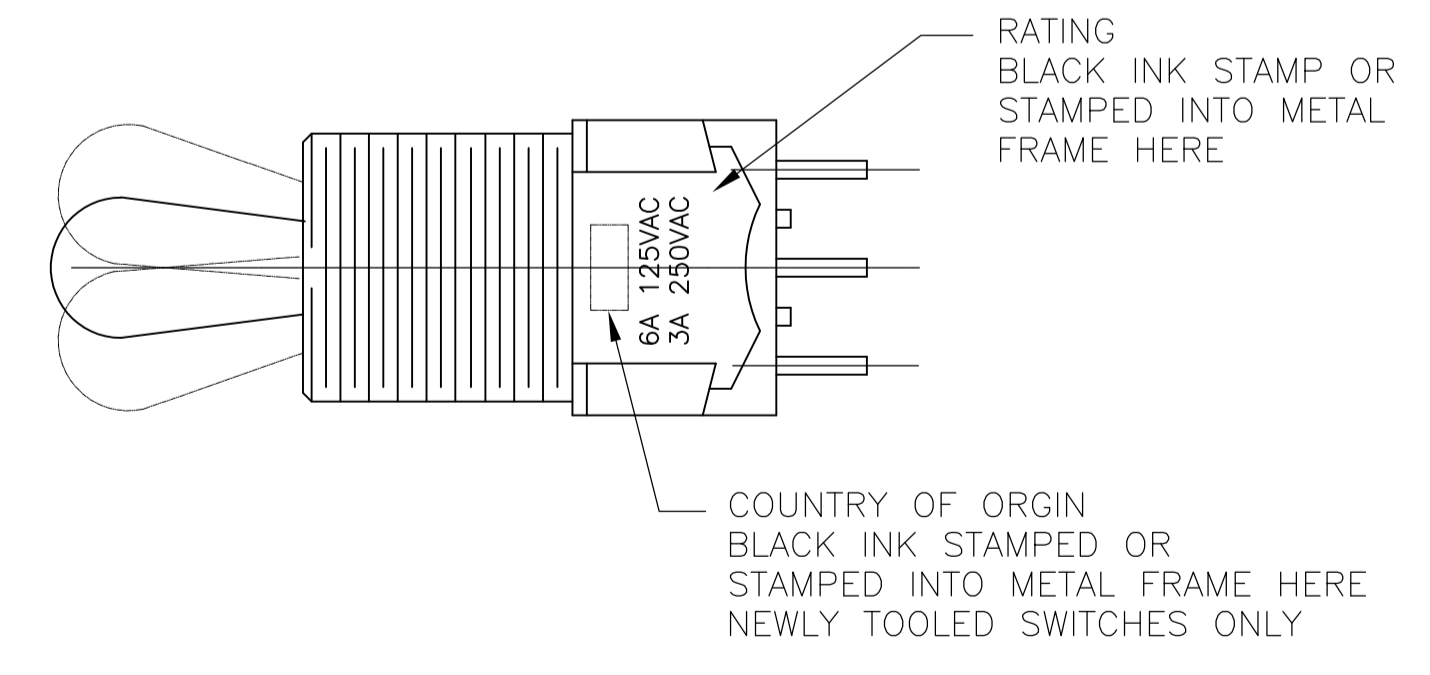

THIS DRAWING IS A CONTROLLED DOCUMENT.		DIN M. BINNER 29DEC03	TE Connectivity
DIMENSIONS: INCHES		CHK M. ZITTO 29DEC03	
TOLERANCES UNLESS OTHERWISE SPECIFIED:		APP'D M. ZITTO 29DEC03	NAME TOGGLE SWITCH, MTG SERIES VERTICAL MOUNT
0. PLC	± .005	PRODUCT SPEC	
1. PLC	± .005	APPLICATION SPEC	
2. PLC	± .005		
3. PLC	± .005		
4. PLC	± .005		
ANGLES	± .005		
MATERIAL		SIZE A1	RESTRICTED TO
FINISH		CAGE CODE 00779	DRAWING NO. 1-1437559-1
CUSTOMER DRAWING		SCALE 3:1	SHEET 2 OF 3
		REV D4	

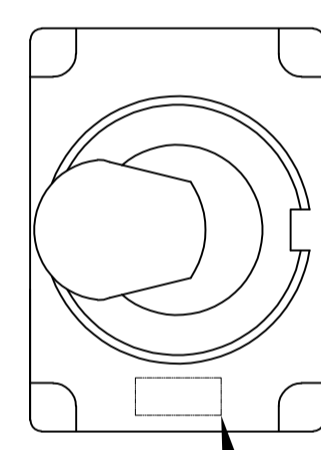
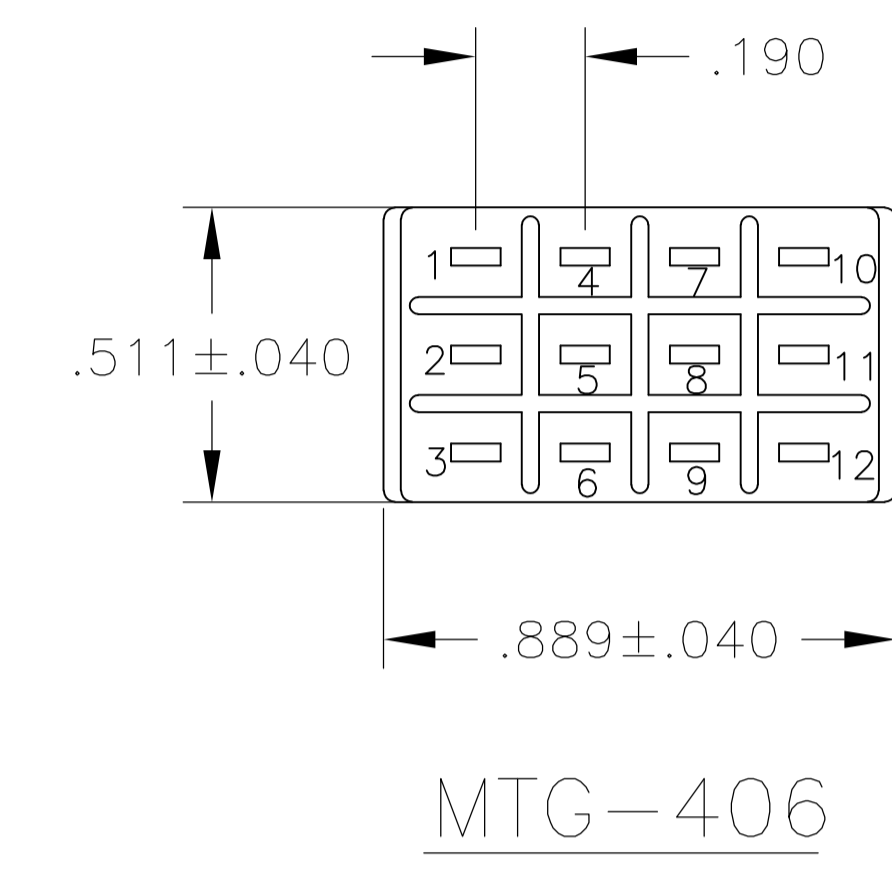
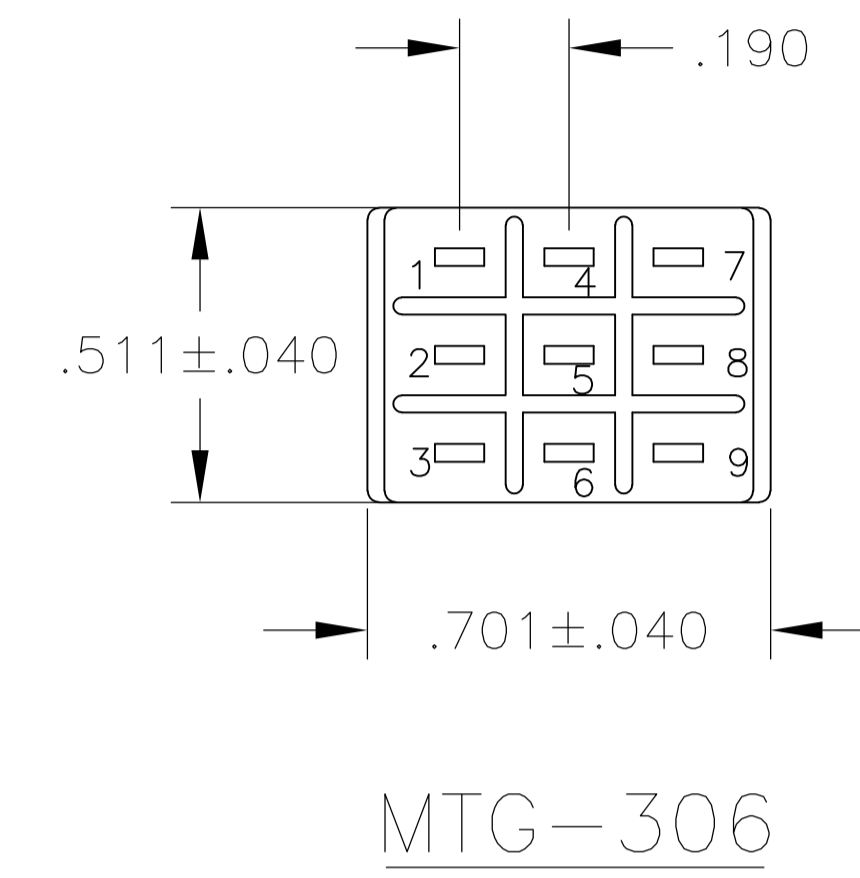
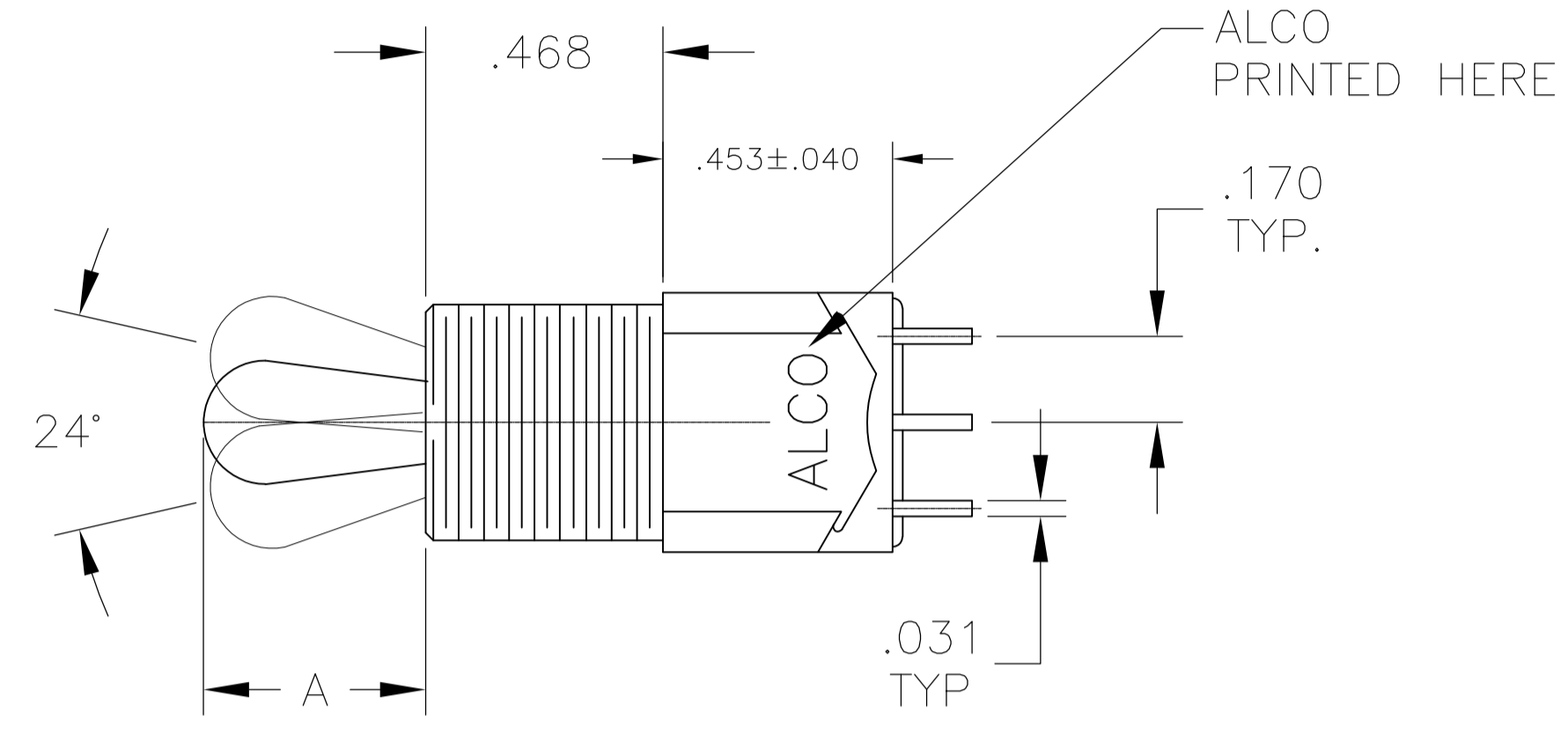

COUNTRY OF ORIGIN STAMPED HERE EXISTING SWITCHES ONLY

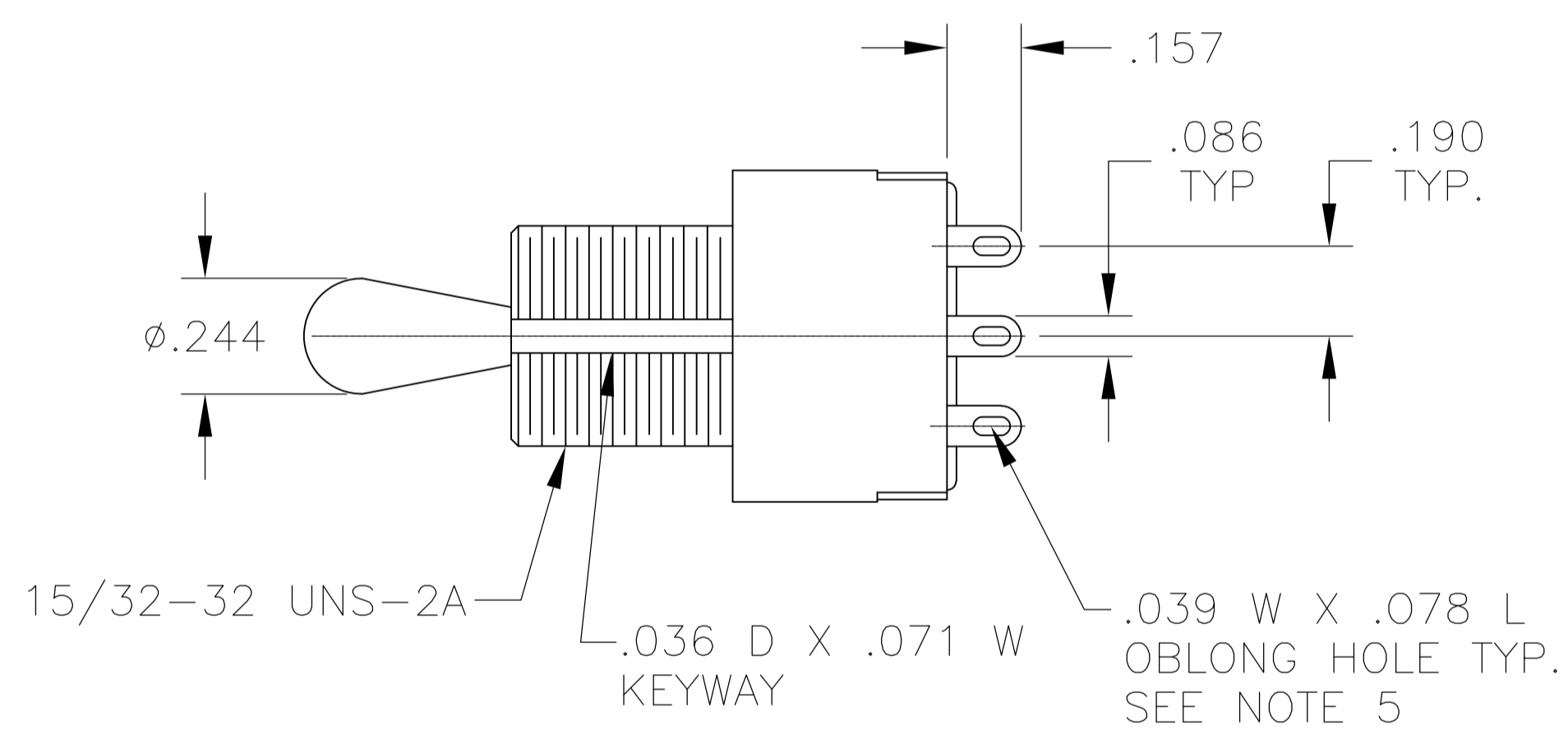

WIRE LUG TERMINAL

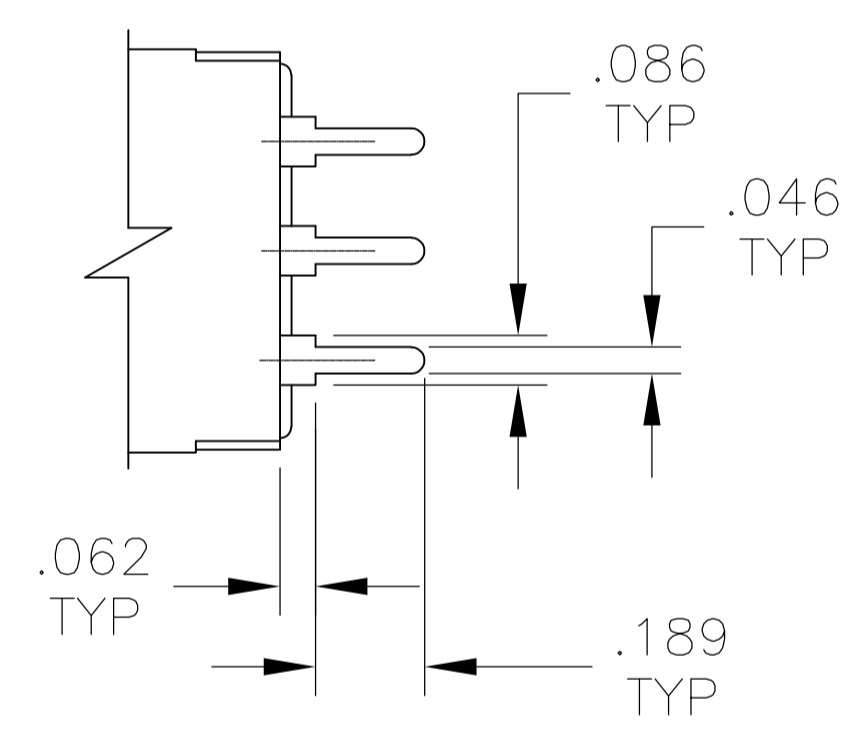

PC TERMINAL

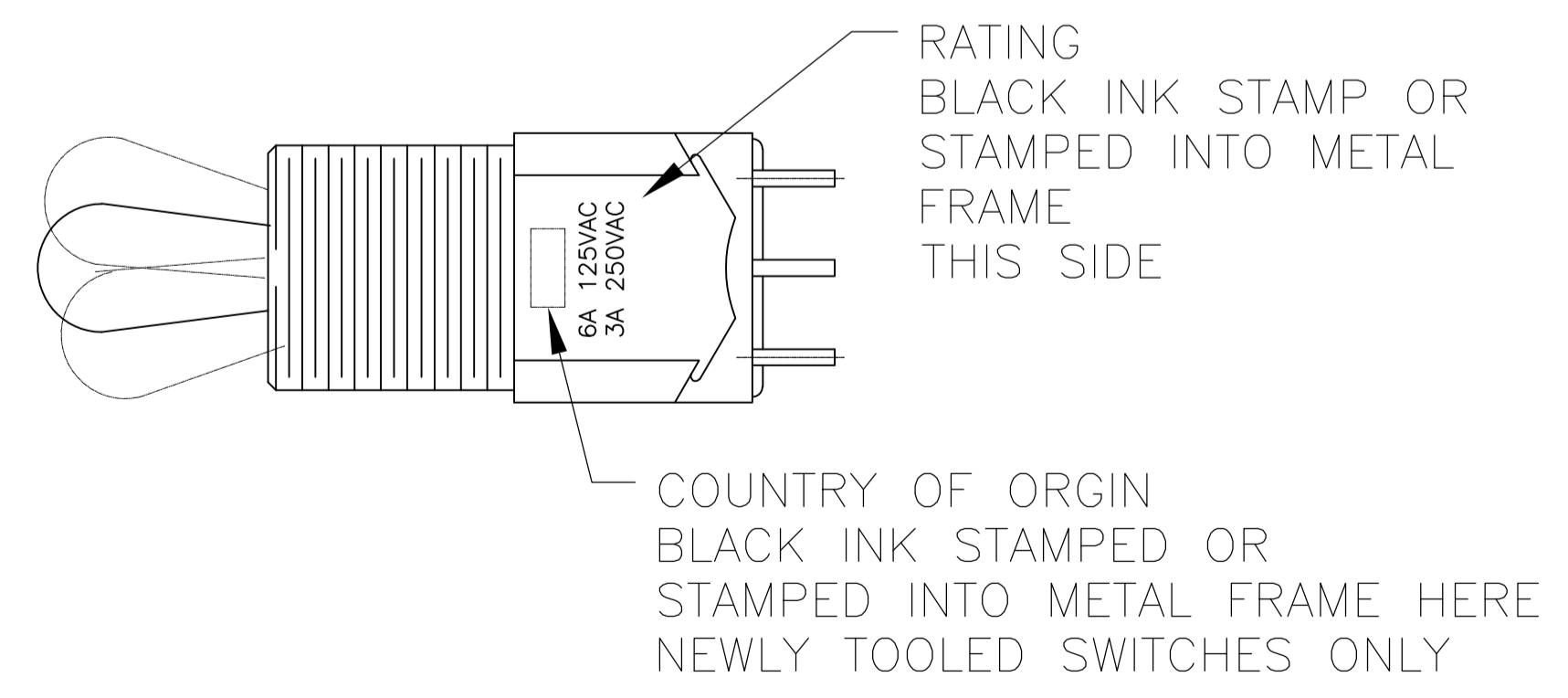

THIS DRAWING IS A CONTROLLED DOCUMENT.		DWN M. BINNER 29DEC03	TE Connectivity
DIMENSIONS: INCHES		CHK M. ZITTO 29DEC03	
TOLERANCES UNLESS OTHERWISE SPECIFIED:		NAME M. ZITTO 29DEC03	TOGGLE SWITCH, MTG SERIES VERTICAL MOUNT
0. PLC ± -		PRODUCT SPEC	
1. PLC ± -		APPLICATION SPEC	SIZE A1
2. PLC ± -		WEIGHT	CAGE CODE 1-1437559-1
3. PLC ± .005		CUSTOMER DRAWING	RESTRICTED TO
4. PLC ± -		SCALE 3:1	SHEET 3 OF 3
ANGLES ± -		REV D4	