



Chipsmall Limited consists of a professional team with an average of over 10 year of expertise in the distribution of electronic components. Based in Hongkong, we have already established firm and mutual-benefit business relationships with customers from,Europe,America and south Asia,supplying obsolete and hard-to-find components to meet their specific needs.

With the principle of “Quality Parts,Customers Priority,Honest Operation,and Considerate Service”,our business mainly focus on the distribution of electronic components. Line cards we deal with include Microchip,ALPS,ROHM,Xilinx,Pulse,ON,Everlight and Freescale. Main products comprise IC,Modules,Potentiometer,IC Socket,Relay,Connector.Our parts cover such applications as commercial,industrial, and automotives areas.

We are looking forward to setting up business relationship with you and hope to provide you with the best service and solution. Let us make a better world for our industry!



Contact us

Tel: +86-755-8981 8866 Fax: +86-755-8427 6832

Email & Skype: info@chipsmall.com Web: www.chipsmall.com

Address: A1208, Overseas Decoration Building, #122 Zhenhua RD., Futian, Shenzhen, China



The MEMSIC MTLT105D-R series is a dynamic tilt sensor with programmable tilt threshold alarm and RS232 Interface. The MTLT105D-R integrates highly reliable MEMS based accelerometers and gyroscopes, a microprocessor to calculate tilt angles and protection circuitry for robust operating environments. The MTLT105D-R has complex sensor fusion and calibration algorithms to achieve a 0.5degree tilt accuracy in a wide variety of dynamic conditions. The MTLT105D-R includes an active high programmable tilt alarm for safety applications. It can be programmed to be triggered when the tilt exceeds a specified user set threshold and can be used to lock out controls or trigger a bell or warning light. The MTLT105D-R is available in a fully enclosed IP67 plastic over-molded enclosure with 1m flying leads.



Applications

- Construction (boom tilt measurement, bucket leveling)
- Tilt/slope safety for dynamic vehicles (forklift, aerial lifts)
- Rollover detection
- Platform Stabilization
- Robotics Control



Construction



Aerial Lift Safety



Platform Stabilization

Features

- High Performance 3 axis MEMS Accelerometer and 3 axis Gyroscope
- 0.5° accuracy in static conditions, 2° accuracy in dynamic conditions
- Gyro compensated for Dynamic conditions
- Programmable Tilt Alarm
- RS232 Interface
- Miniature IP67 enclosure (54 x 40 x 15 mm)
- Wide Temp Range, -40C to +70C
- High Reliability, MTBF > 50k hours
- ITAR- Free

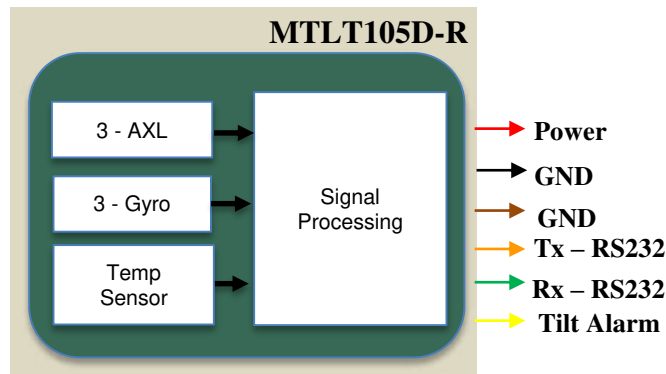



Performance Characteristics

Ta = 25°C, VDC = 15.0V, unless otherwise stated

Sensor Performance	
Axes	6
Range	90°, 180°
Resolution	0.05°
Static Accuracy ¹	0.5°
Dynamic Accuracy ¹	2.0°
Programmable Tilt Alarm	
Vout (V)	3.3
Bandwidth(Hz)	50
Electrical	
Input Voltage (V)	9 to 32
Power Consumption (mW)	< 400
Interface	RS232
Environment	
Operating Temperature (°C)	-40 °C to 70°C
Non-Operating Temperature (°C)	-55 °C to 85°C
Physical	
Enclosure	Plastic
Size (mm)	54 x 40 x 15
Protection Class	IP67

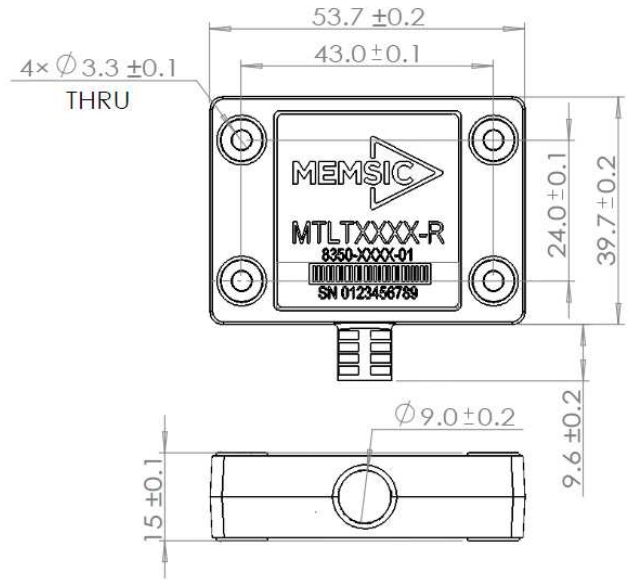

* All dimensions in mm

Tools and Support

NAV-VIEW provides an easy to use graphical interface to display, record, playback, and analyze all of the MTLT105D-R parameters.

NAV-VIEW can also be used to set a wide range of user-configurable fields in the MTLT105D-R to optimize the system performance for highly dynamic applications.

NAV-VIEW software is available for download from MEMSIC's website at: www.memsic.com/support

Pin Out Description

Pin Number	Flying Lead Color	Pin Description
1	Red	Power
2	Black	GND
3	Brown	GND
4	Orange	RS232 Tx
5	Green	RS232 Rx
6	Yellow	Tilt Alarm

Part Ordering Information

MTLT105D-R	0.5° High Performance Dynamic Tilt Sensor Module
------------	--

This product has been developed exclusively for commercial applications. It has not been tested for, and makes no representation or warranty as to conformance with, any military specifications or its suitability for any military application or end-use. Additionally, any use of this product for nuclear, chemical or biological weapons, or weapons research, or for any use in missiles, rockets, and/or UAV's of 300km or greater range, or any other activity prohibited by the Export Administration Regulations, is expressly prohibited without the written consent and without obtaining appropriate US export license(s) when required by US law. Diversion contrary to U.S. law is prohibited. Specifications are subject to change without notice.

¹ RMS Error