



Chipsmall Limited consists of a professional team with an average of over 10 year of expertise in the distribution of electronic components. Based in Hongkong, we have already established firm and mutual-benefit business relationships with customers from,Europe,America and south Asia,supplying obsolete and hard-to-find components to meet their specific needs.

With the principle of "Quality Parts,Customers Priority,Honest Operation,and Considerate Service",our business mainly focus on the distribution of electronic components. Line cards we deal with include Microchip,ALPS,ROHM,Xilinx,Pulse,ON,Everlight and Freescale. Main products comprise IC,Modules,Potentiometer,IC Socket,Relay,Connector.Our parts cover such applications as commercial,industrial, and automotives areas.

We are looking forward to setting up business relationship with you and hope to provide you with the best service and solution. Let us make a better world for our industry!



Contact us

Tel: +86-755-8981 8866 Fax: +86-755-8427 6832

Email & Skype: info@chipsmall.com Web: www.chipsmall.com

Address: A1208, Overseas Decoration Building, #122 Zhenhua RD., Futian, Shenzhen, China



Instruction Manual for Evaluation Board of The TB6642FTG

July 28, 2016

Rev.1.0

【Outline】

The TB6642FTG is a brushed DC motor driver corresponding to the direct PWM control system.

BiCD process is adopted. Ratings of 50V and 4.5A (@ Power supply voltage (VM) ≤ 36V) are realized. When the power supply voltage (VM) is more than 36V, please use the IC by configuring the current range of 4.0A or less.

This evaluation board mounts necessary components to evaluate the IC.

Brushed DC motor can be controlled by the direct PWM drive.

Please sense controllability of a brushed DC motor by applying the TB6642FTG.

【Note】

In using, please be careful about the thermal condition sufficiently.

For each control signal, please refer to the IC specifications by accessing to the following URL:

<http://toshiba.semicon-storage.com/ap-en/product/linear/motordriver/detail.TB6642FTG.html>

Further, the application of this evaluation board is limited to the purpose of evaluating and learning the motor control. Please do not ship them to a market.

Connection to Evaluation Board 【Direct PWM Control】

*Supply the power in using the switch on the board.

Correspondence table of silk name and signal name

Please pay attention that the silk name and the signal name of the board are different because the TB6642FTG and the series ICs use the common board.

Silk name	Signal name
VREF	NC

Power supply for board: VDD (3.0V to 5.5V)

Power supply for motor: VM (10V to 47V)

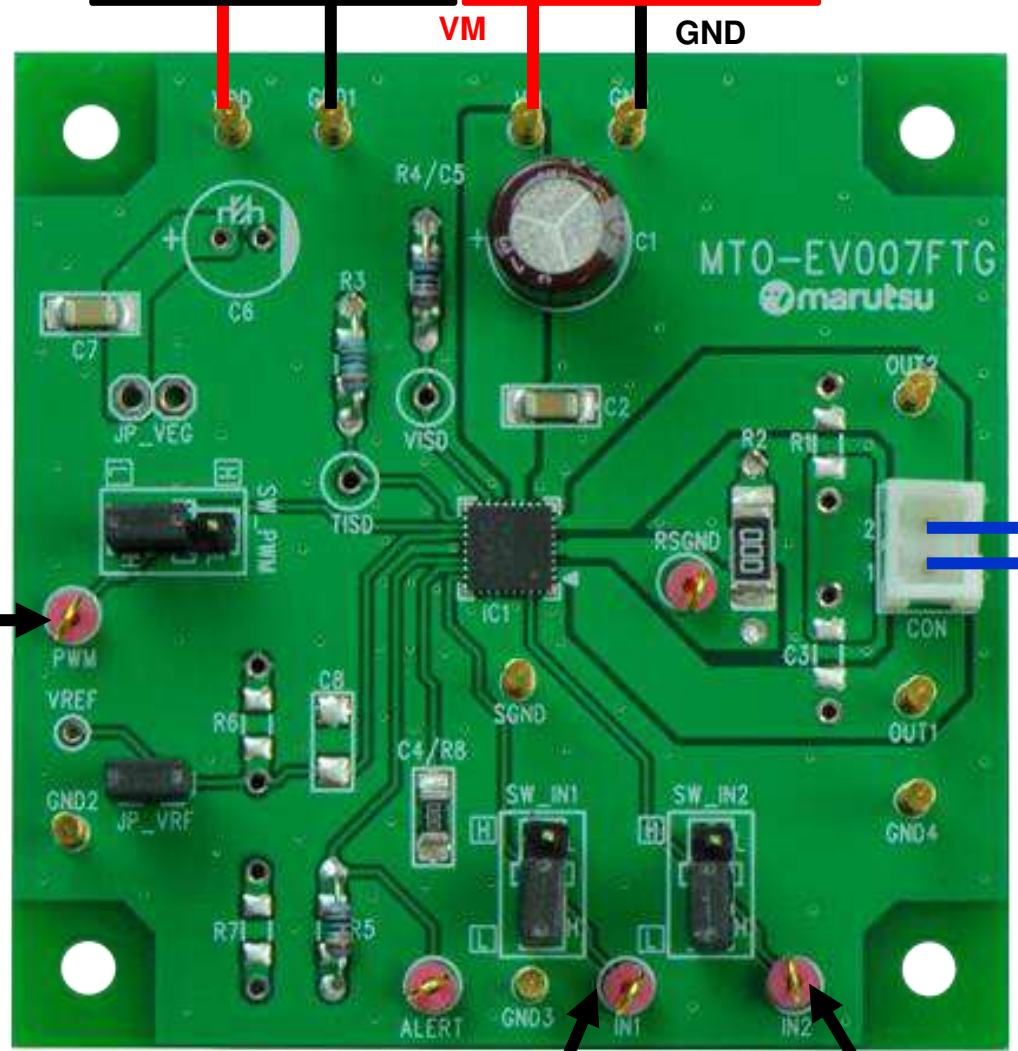

Motor control signal input

Motor control signal input

Brushed DC motor

Setting Evaluation Board

Setting motor operation



【Enhanced figure of jumper part】

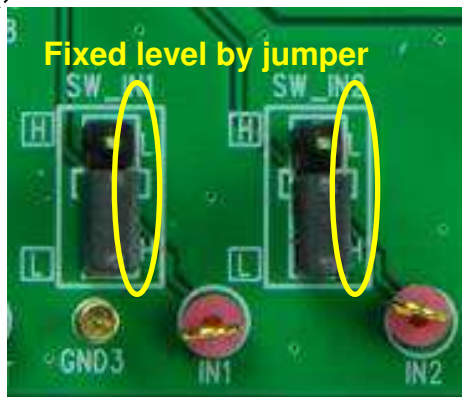

Jumper indicated on the left is adopted on this evaluation board to set operation of the TB6642FTG. To select the function by the jumper, supply the voltage of high level by VDD pin. In the left figure, fixed level of the silk near the jumper is indicated inside the white frame. Please change the short position according to the configuration of the usage function. In case of inputting the signal externally, please remove the short pin.

Circuit of Evaluation Board

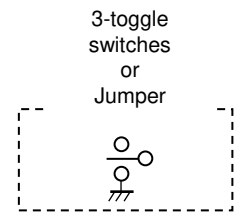
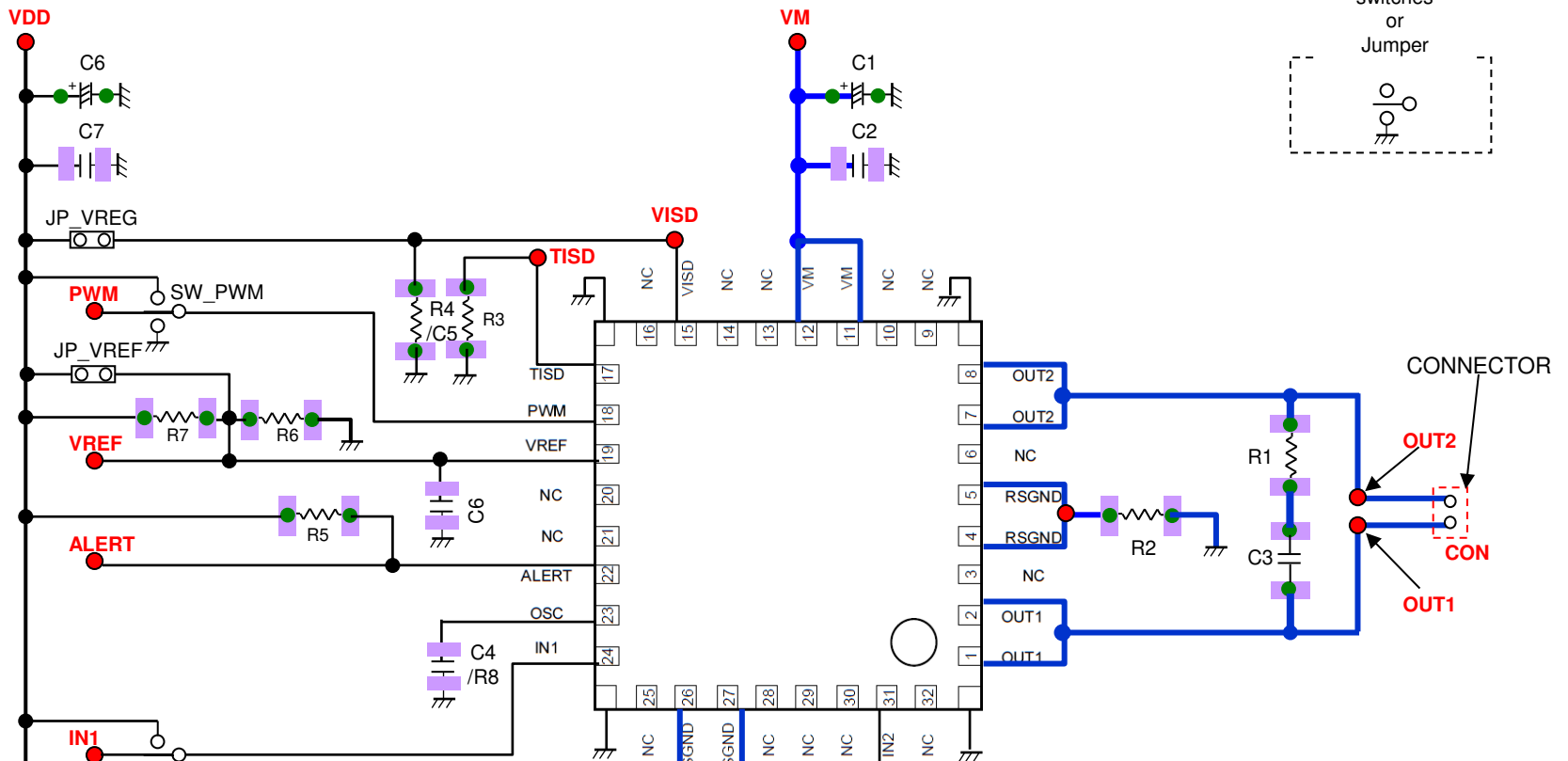

- : Socket pin
- : Check pin
- : Jumper
- ■ : Solder land + Through hole (Please provide the land for surface-mounting component which has a through hole.)
- : Solder land