



Chipsmall Limited consists of a professional team with an average of over 10 year of expertise in the distribution of electronic components. Based in Hongkong, we have already established firm and mutual-benefit business relationships with customers from,Europe,America and south Asia,supplying obsolete and hard-to-find components to meet their specific needs.

With the principle of “Quality Parts,Customers Priority,Honest Operation,and Considerate Service”,our business mainly focus on the distribution of electronic components. Line cards we deal with include Microchip,ALPS,ROHM,Xilinx,Pulse,ON,Everlight and Freescale. Main products comprise IC,Modules,Potentiometer,IC Socket,Relay,Connector.Our parts cover such applications as commercial,industrial, and automotives areas.

We are looking forward to setting up business relationship with you and hope to provide you with the best service and solution. Let us make a better world for our industry!



Contact us

Tel: +86-755-8981 8866 Fax: +86-755-8427 6832

Email & Skype: info@chipsmall.com Web: www.chipsmall.com

Address: A1208, Overseas Decoration Building, #122 Zhenhua RD., Futian, Shenzhen, China



Instruction manual for Evaluation Board of TB67S215FTAG

May 16, 2016

Re v.1.0

【Outline】

The TB67S215 is a two-phase bipolar stepping motor driver using a PWM chopper. CLK-IN control system and BiCD process are adopted. Rating of 40V and 2.5A is realized.

This evaluation board mounts necessary components to evaluate the IC. Each excitation drive of full step, half step and quarter step can be run with PWM constant current drive. Please sense low noise and low vibration of the stepping motor.

【Note】

In using, please be careful about thermal condition sufficiently.

As for each control signal, please refer to the IC specification by accessing to the below URL.

<http://toshiba.semicon-storage.com/info/lookup.jsp?pid=TB62262FTAG®ion=apc&lang=en>

Further, the application of this evaluation board is limited to the purpose of evaluating and learning the motor control. Please do not ship them to a market.

Connection to Evaluation board

Corresponding table

(Silk name vs. Signal name)

(Note) Silk name and signal name on the board are same on the TB67S215FTAG.

Silk name	Signal name
CLK	CLK
ENABLE	ENABLE
RESET	RESET
CW/CCW	CW/CCW
MO	MO
DMODE_1	DMODE_1
DMODE_2	DMODE_2

Power source of VM (10V to 47V)

VM
GND

Two-phase bipolar type Stepping motor

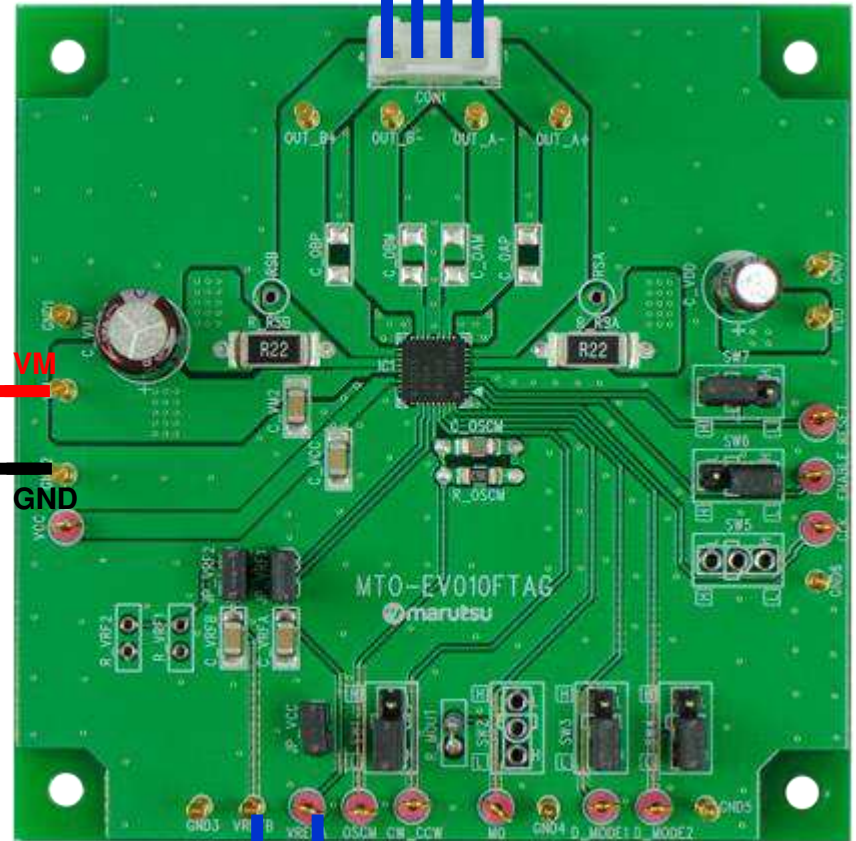

VrefB(for B-axis)

VrefA(for A-axis)

Reference voltage for motor current set Vref (0V to 3.6V)

Setting evaluation board 1

Setting motor current

Setting motor current

$$I_{out(max)} = VREF(gain) \times \frac{Vref(V)}{RRS(\Omega)}$$

VREF(gain): Decay ratio of VREF: 1/5.0 (typ.)

RRS=0.22Ω

VREF of A-axis and B-axis are made common by short the jumper (JP_VRF1) and the both voltages are possible to input from VREFA pin. And Vref can be generated from the internal regulator (VCC) by mounting the divider resistance to R_VRF1 and R_VRF2 and short-circuiting JP_VRF2.

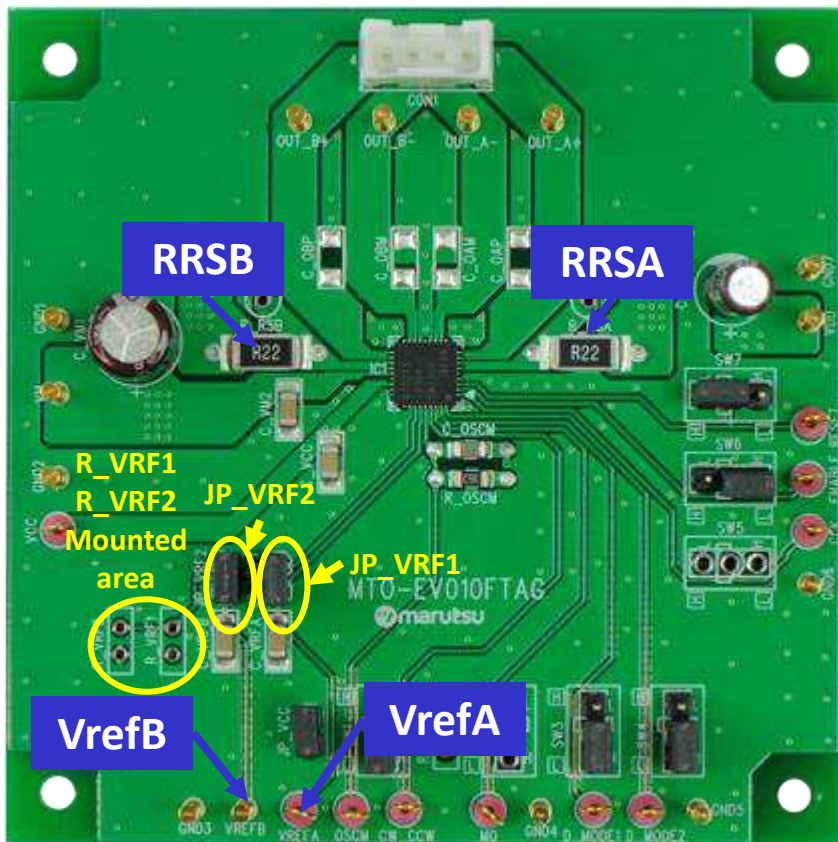

Waveform of motor current

Current value of setting motor

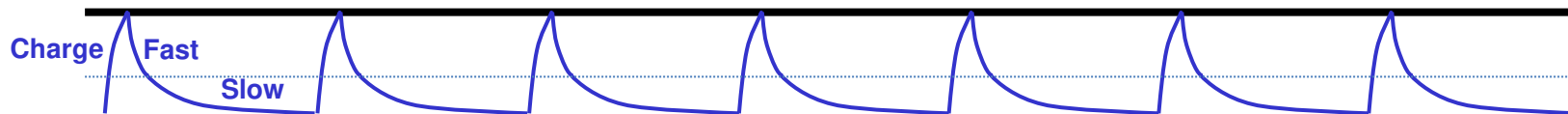

Setting evaluation board2

Setting chopping frequency of the constant current of the motor

Formula of setting chopping frequency

$$f_{OSCM} = 1 / [0.56 \times \{C \times (R1 + 500)\}]$$

$$f_{chop} = f_{OSCM} / 16$$

Recommended frequency range:

f_{chop} =40kHz to 150kHz

100kHz configuration

Mounted parts are as follows;

Capacitor (C=270pF), Resistance (R1=3.6kΩ)

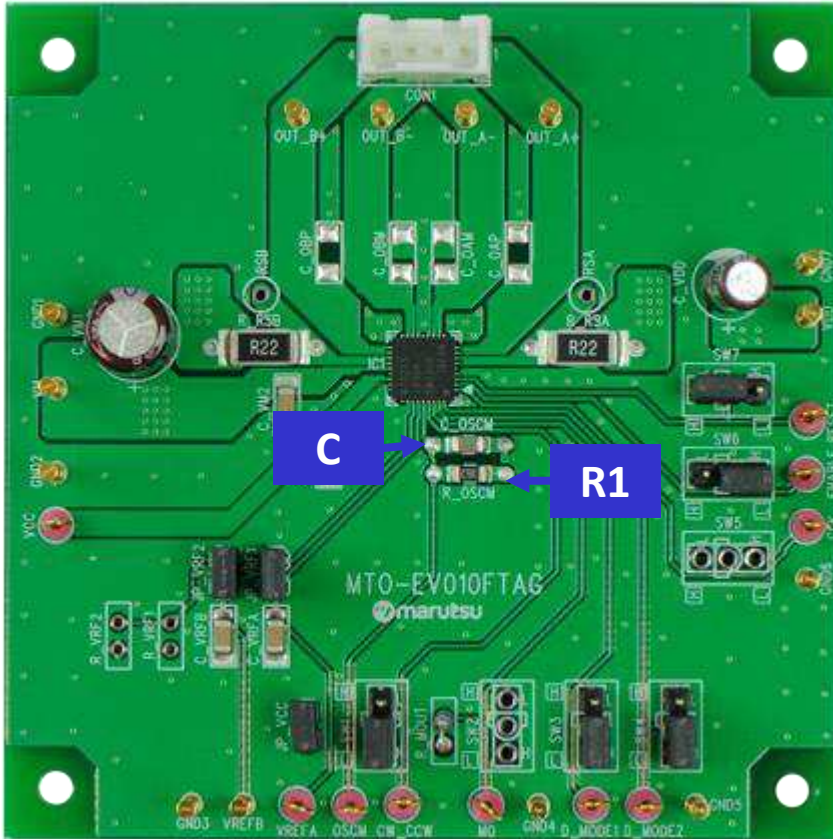

Waveform of motor current

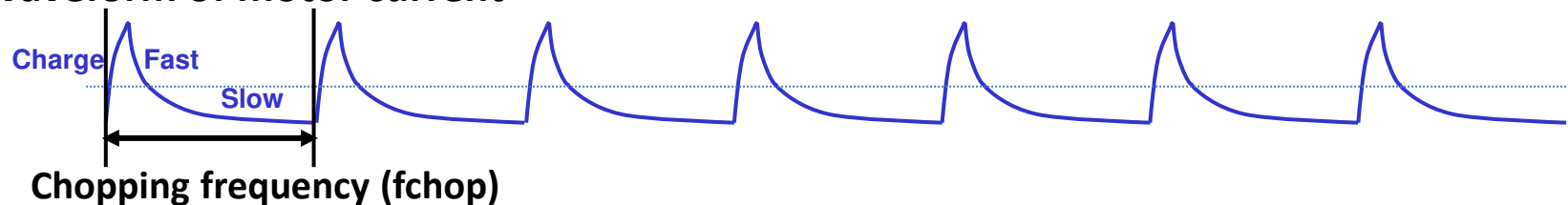

Setting evaluation board3

Setting motor operation

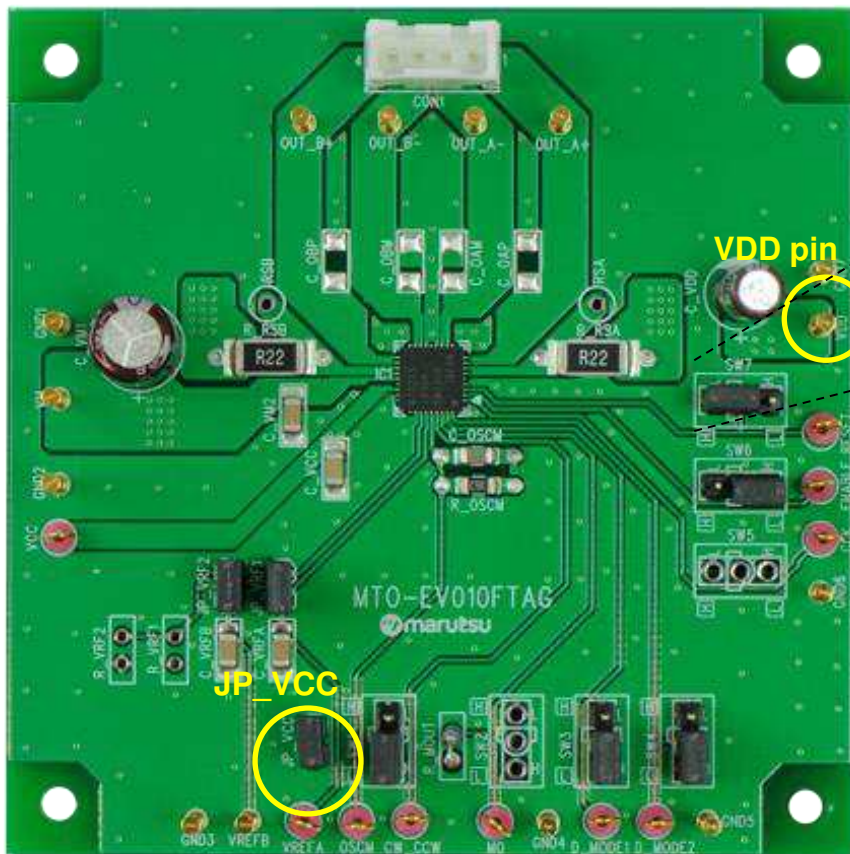

【Enhanced figure of jumper part】



Jumper indicated above is adopted on this evaluation board to set operation of the TB67S215FTAG.

To select the function by the jumper, short-circuit JP_VCC or supply the voltage of high level by VDD pin.

In above, fixed level of the silk near the jumper is indicated inside the white frame. Please change the short position according to the configuration of the usage function.

In case of inputting the signal externally, please remove the short pin.

Circuit of evaluation board

