



Chipsmall Limited consists of a professional team with an average of over 10 year of expertise in the distribution of electronic components. Based in Hongkong, we have already established firm and mutual-benefit business relationships with customers from,Europe,America and south Asia,supplying obsolete and hard-to-find components to meet their specific needs.

With the principle of “Quality Parts,Customers Priority,Honest Operation,and Considerate Service”,our business mainly focus on the distribution of electronic components. Line cards we deal with include Microchip,ALPS,ROHM,Xilinx,Pulse,ON,Everlight and Freescale. Main products comprise IC,Modules,Potentiometer,IC Socket,Relay,Connector.Our parts cover such applications as commercial,industrial, and automotives areas.

We are looking forward to setting up business relationship with you and hope to provide you with the best service and solution. Let us make a better world for our industry!



## Contact us

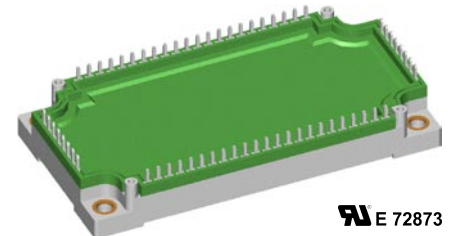
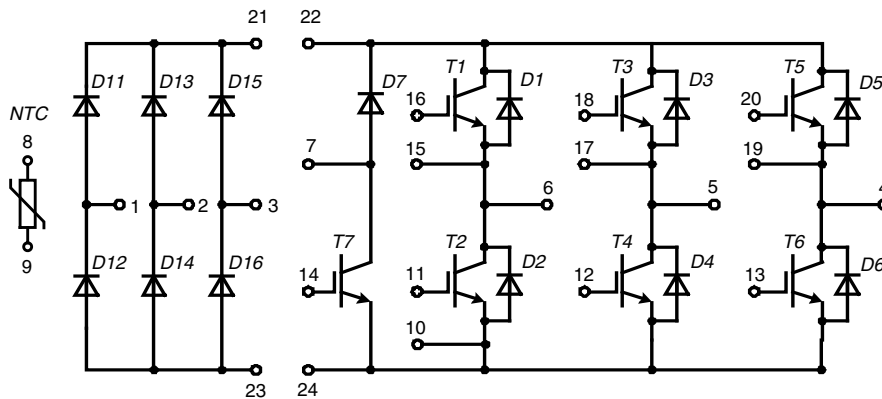
Tel: +86-755-8981 8866 Fax: +86-755-8427 6832

Email & Skype: info@chipsmall.com Web: www.chipsmall.com

Address: A1208, Overseas Decoration Building, #122 Zhenhua RD., Futian, Shenzhen, China



# Converter - Brake - Inverter Module (CBI3) with Trench IGBT technology



E 72873

Three Phase Rectifier	Brake Chopper	Three Phase Inverter
$V_{RRM} = 1600 \text{ V}$	$V_{CES} = 1200 \text{ V}$	$V_{CES} = 1200 \text{ V}$
$I_{FAVM} = 65 \text{ A}$	$I_{C25} = 55 \text{ A}$	$I_{C25} = 110 \text{ A}$
$I_{FSM} = 1100 \text{ A}$	$V_{CE(sat)} = 1.7 \text{ V}$	$V_{CE(sat)} = 1.7 \text{ V}$

Input Rectifier Bridge D11 - D16			
Symbol	Conditions	Maximum Ratings	
$V_{RRM}$		1600	V
$I_{FAV}$	$T_C = 80^\circ\text{C}$ ; sine $180^\circ$	65	A
$I_{DAVM}$	$T_C = 80^\circ\text{C}$ ; rectangular; $d = 1/3$ ; bridge	180	A
$I_{FSM}$	$T_C = 25^\circ\text{C}$ ; $t = 10 \text{ ms}$ ; sine 50 Hz	1100	A
$P_{tot}$	$T_C = 25^\circ\text{C}$	155	W

Symbol	Conditions	Characteristic Values			
		min.	typ.	max.	
$(T_{VJ} = 25^\circ\text{C}, \text{ unless otherwise specified})$					
$V_F$	$I_F = 75 \text{ A}$ ; $T_{VJ} = 25^\circ\text{C}$		1.15	1.3	V
		$T_{VJ} = 125^\circ\text{C}$		1.05	
$I_R$	$V_R = V_{RRM}$ ; $T_{VJ} = 25^\circ\text{C}$		0.8	0.05	mA
	$T_{VJ} = 125^\circ\text{C}$				mA
$R_{thJC}$	(per diode)			0.8	K/W

### Application: AC motor drives with

- Input from single or three phase grid
- Three phase synchronous or asynchronous motor
- Electric braking operation

### Features

- High level of integration - only one power semiconductor module required for the whole drive
- IGBT technology with low saturation voltage, low switching losses and tail current, high RBSOA and short circuit ruggedness
- Epitaxial free wheeling diodes with Hiperfast and soft reverse recovery
- Industry standard package with insulated copper base plate and soldering pins for PCB mounting
- Temperature sense included

Output Inverter T1 - T6			
Symbol	Conditions	Maximum Ratings	
$V_{CES}$	$T_{VJ} = 25^{\circ}\text{C}$ to $150^{\circ}\text{C}$	1200	V
$V_{GES}$	Continuous	$\pm 20$	V
$I_{C25}$	$T_C = 25^{\circ}\text{C}$	110	A
$I_{C80}$	$T_C = 80^{\circ}\text{C}$	75	A
$I_{CM}$	$T_C = 80^{\circ}\text{C}; t_p = 1 \text{ ms}$	150	A
$P_{tot}$	$T_C = 25^{\circ}\text{C}$	355	W

Symbol	Conditions	Characteristic Values			
		(T <sub>VJ</sub> = 25°C, unless otherwise specified)			
		min.	typ.	max.	
$V_{CE(sat)}$	$I_C = 75 \text{ A}; V_{GE} = 15 \text{ V}$				$T_{VJ} = 25^{\circ}\text{C}$
					$T_{VJ} = 125^{\circ}\text{C}$
$V_{GE(th)}$	$I_C = 3 \text{ mA}; V_{GE} = V_{CE}$	5	5.8	6.5	V
$I_{CES}$	$V_{CE} = V_{CES}; V_{GE} = 0 \text{ V}$		1	4	mA mA
$I_{GES}$	$V_{CE} = 0 \text{ V}; V_{GE} = \pm 20 \text{ V}$			400	nA
$C_{ies}$	$V_{CE} = 25 \text{ V}; V_{GE} = 0 \text{ V}; f = 1 \text{ MHz}$		5.35		nF
$Q_{Gon}$	$V_{CE} = 600 \text{ V}; V_{GE} = 15 \text{ V}; I_C = 75 \text{ A}$		700		nC
$t_{d(on)}$ $t_r$ $t_{d(off)}$ $t_f$ $E_{on}$ $E_{off}$	Inductive load, $T_{VJ} = 125^{\circ}\text{C}$ $V_{CE} = 600 \text{ V}; I_C = 75 \text{ A}$ $V_{GE} = \pm 15 \text{ V}; R_G = 4.7 \Omega$				290
					50
					520
					90
					7
					9.5
<b>RBSOA</b>	$I_C = I_{CM}; V_{GE} = 15 \text{ V}$ $R_G = 4.7 \Omega; T_{VJ} = 125^{\circ}\text{C}$				$V_{CEK} \leq V_{CES} - L_S di/dt$
<b><math>t_{SC}</math></b> <b>(SCSOA)</b>	$V_{CE} = 720 \text{ V}; V_{GE} = \pm 15 \text{ V}; R_G = 4.7 \Omega$ $t_p \leq 10 \mu\text{s}; \text{non-repetitive}; T_{VJ} = 125^{\circ}\text{C}$		300		A
$R_{thJC}$				0.35	K/W

Output Inverter D1 - D6					
Symbol	Conditions	Maximum Ratings			
$I_{F25}$	$T_C = 25^{\circ}\text{C}$	155	A		
$I_{F80}$	$T_C = 80^{\circ}\text{C}$	75	A		
Symbol	Conditions	Characteristic Values			
		min.	typ.	max.	
$V_F$	$I_F = 75 \text{ A};$				$T_{VJ} = 25^{\circ}\text{C}$
					$T_{VJ} = 125^{\circ}\text{C}$
$I_{RM}$ $Q_{rr}$ $t_{rr}$ $E_{rec}$	$I_F = 75 \text{ A}; di_F/dt = -1500 \text{ A}/\mu\text{s};$ $T_{VJ} = 125^{\circ}\text{C}; V_R = 600 \text{ V}; V_{GE} = 0 \text{ V}$				135
					15
					160
					6
					6
$R_{thJC}$	(per diode)				0.4



<b>Brake Chopper T7</b>			
<b>Symbol</b>	<b>Conditions</b>	<b>Maximum Ratings</b>	
$V_{CES}$	$T_{VJ} = 25^{\circ}\text{C}$ to $150^{\circ}\text{C}$	1200	V
$V_{GES}$	Continuous	$\pm 20$	V
$I_{C25}$	$T_C = 25^{\circ}\text{C}$	55	A
$I_{C80}$	$T_C = 80^{\circ}\text{C}$	35	A
$I_{CM}$	$T_C = 80^{\circ}\text{C}$ ; $t_p = 1$ ms	70	A
$P_{tot}$	$T_C = 25^{\circ}\text{C}$	200	W

<b>Symbol</b>	<b>Conditions</b>	<b>Characteristic Values</b>				
		$(T_{VJ} = 25^{\circ}\text{C}, \text{ unless otherwise specified})$				
		<b>min.</b>	<b>typ.</b>	<b>max.</b>		
$V_{CE(sat)}$	$I_C = 35$ A; $V_{GE} = 15$ V			1.7	2.15	V
				$T_{VJ} = 25^{\circ}\text{C}$	2.0	
$V_{GE(th)}$	$I_C = 1.5$ mA; $V_{GE} = V_{CE}$	5	5.8	6.5	V	
$I_{CES}$	$V_{CE} = V_{CES}$ ; $V_{GE} = 0$ V			0.25		mA
				$T_{VJ} = 25^{\circ}\text{C}$	0.3	
$I_{GES}$	$V_{CE} = 0$ V; $V_{GE} = \pm 20$ V			400	nA	
$C_{ies}$	$V_{CE} = 25$ V; $V_{GE} = 0$ V; $f = 1$ MHz		2.5		nF	
$Q_{Gon}$	$V_{CE} = 600$ V; $V_{GE} = 15$ V; $I_C = 35$ A		330		nC	
$t_{d(on)}$ $t_r$ $t_{d(off)}$ $t_f$ $E_{off}$	Inductive load, $T_{VJ} = 125^{\circ}\text{C}$ $V_{CE} = 600$ V; $I_C = 35$ A $V_{GE} = \pm 15$ V; $R_G = 27$ $\Omega$			90		ns
				50		ns
				520		ns
				90		ns
				4.8		mJ
<b>RBSOA</b>	$I_C = I_{CM}$ ; $V_{GE} = 15$ V $R_G = 27$ $\Omega$ ; $T_{VJ} = 125^{\circ}\text{C}$		$V_{CEK} \leq V_{CES} - L_S di/dt$		V	
<b><math>t_{SC}</math></b> <b>(SCSOA)</b>	$V_{CE} = 720$ V; $V_{GE} = \pm 15$ V; $R_G = 27$ $\Omega$ $t_p \leq 10$ $\mu\text{s}$ ; non-repetitive; $T_{VJ} = 125^{\circ}\text{C}$		140		A	
$R_{thJC}$				0.62	K/W	

<b>Brake Chopper D7</b>			
<b>Symbol</b>	<b>Conditions</b>	<b>Maximum Ratings</b>	
$V_{RRM}$	$T_{VJ} = 25^{\circ}\text{C}$ to $150^{\circ}\text{C}$	1200	V
$I_{F25}$	$T_C = 25^{\circ}\text{C}$	50	A
$I_{F80}$	$T_C = 80^{\circ}\text{C}$	30	A

<b>Symbol</b>	<b>Conditions</b>	<b>Characteristic Values</b>				
		<b>min.</b>	<b>typ.</b>	<b>max.</b>		
$V_F$	$I_F = 35$ A;			2.5	3.3	V
				$T_{VJ} = 25^{\circ}\text{C}$	2.0	
$I_R$	$V_R = V_{RRM}$ ;			0.25		mA
				$T_{VJ} = 25^{\circ}\text{C}$	0.5	
$R_{thJC}$	(per diode)			1.2	K/W	



**Input Rectifier Bridge D11 - D16**

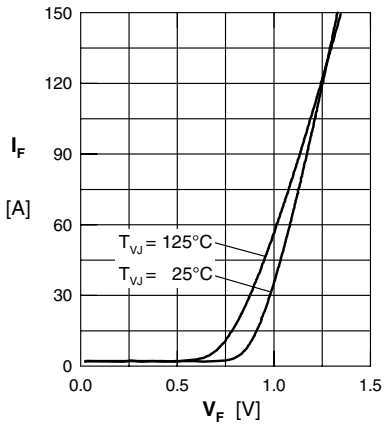


Fig. 1 Typ. forward current vs. voltage drop per diode

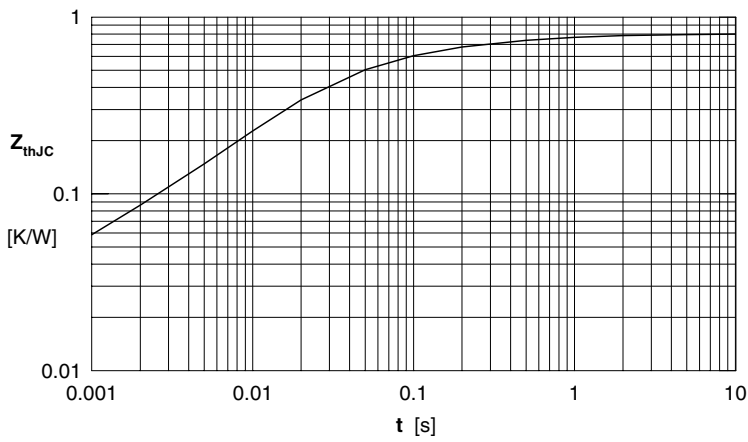


Fig. 2 Transient thermal impedance junction to case

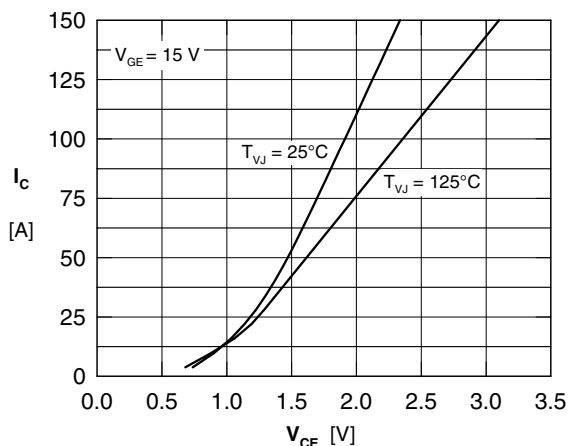
**Output Inverter T1 - T6 / D1 - D6**


Fig. 3 Typical output characteristic

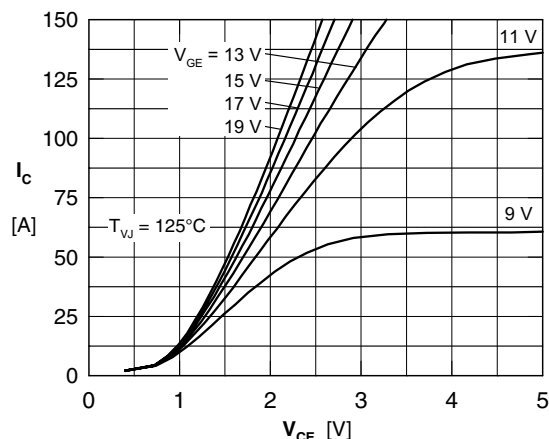


Fig. 4 Typical output characteristic

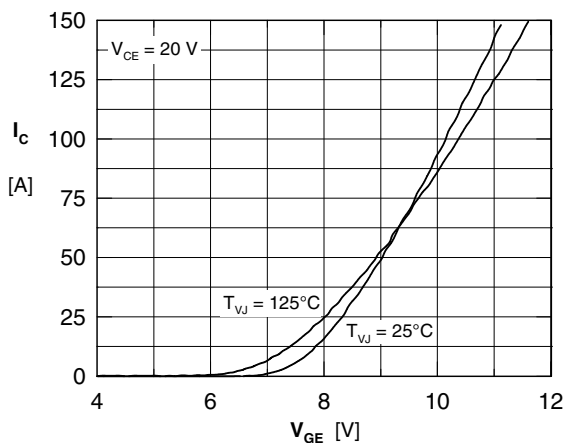


Fig. 5 Typical transfer characteristic

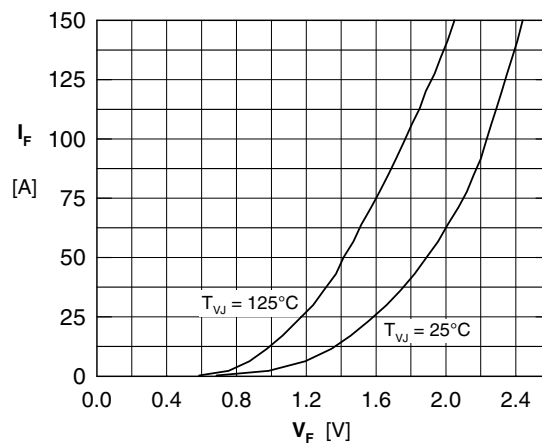


Fig. 6 Typical forward characteristic of free wheeling diode

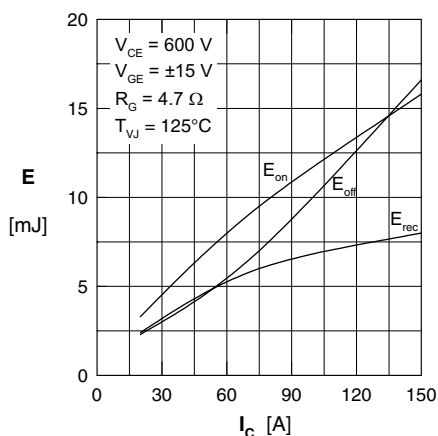


Fig. 7 Typical switching losses vs. collector current

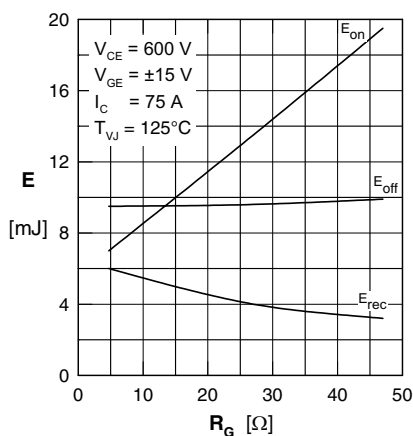


Fig. 8 Typ. switching losses vs. gate resistance

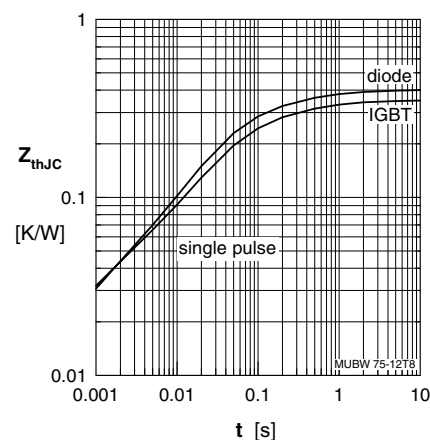


Fig. 9 Transient thermal impedance

**Brake Chopper T7 / D7**

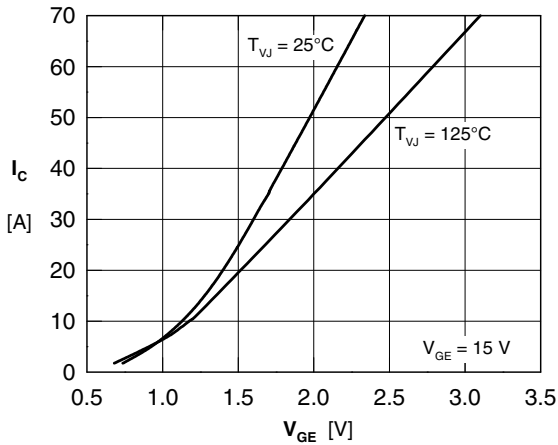


Fig. 10 Typical output characteristics

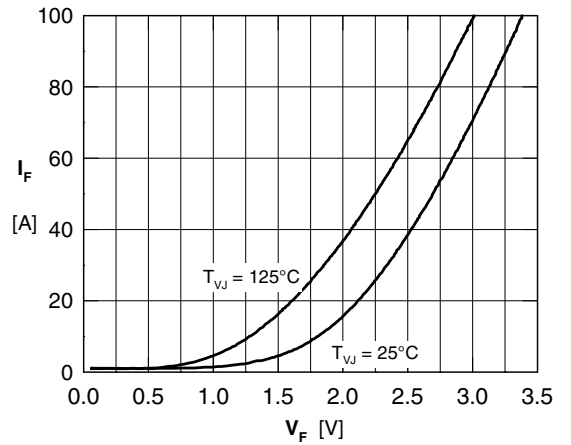


Fig. 11 Typical forward characteristics of free wheeling diode

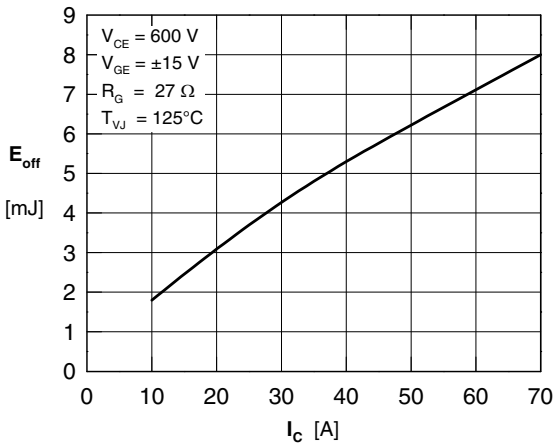


Fig. 12 Typ. turn off energy vs. collector current

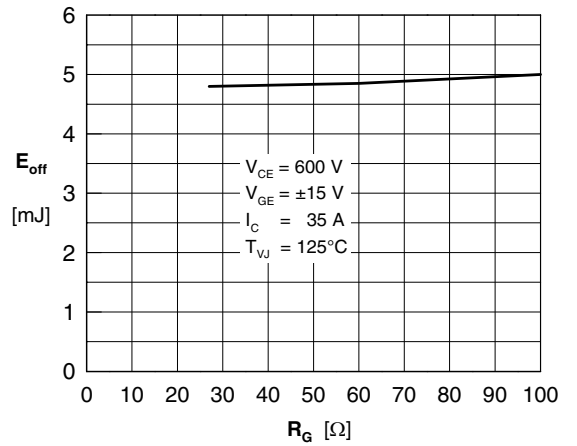


Fig. 13 Typ. turn off energy vs. gate resistor

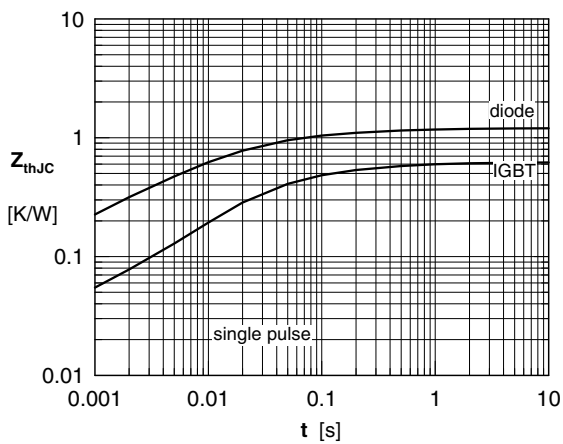


Fig. 14 Transient thermal impedance

**Temperature Sensor NTC**

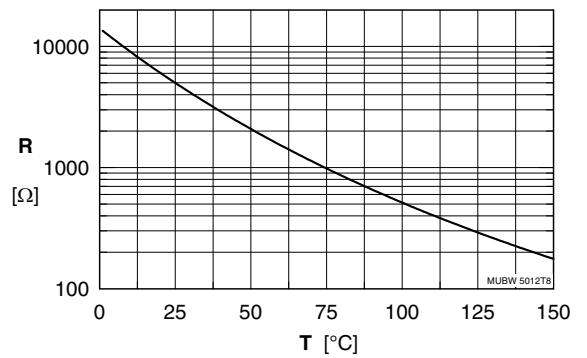


Fig. 15 Typ. termistor resistance versus temperature