



Chipsmall Limited consists of a professional team with an average of over 10 year of expertise in the distribution of electronic components. Based in Hongkong, we have already established firm and mutual-benefit business relationships with customers from,Europe,America and south Asia,supplying obsolete and hard-to-find components to meet their specific needs.

With the principle of "Quality Parts,Customers Priority,Honest Operation,and Considerate Service",our business mainly focus on the distribution of electronic components. Line cards we deal with include Microchip,ALPS,ROHM,Xilinx,Pulse,ON,Everlight and Freescale. Main products comprise IC,Modules,Potentiometer,IC Socket,Relay,Connector.Our parts cover such applications as commercial,industrial, and automotives areas.

We are looking forward to setting up business relationship with you and hope to provide you with the best service and solution. Let us make a better world for our industry!



## Contact us

Tel: +86-755-8981 8866 Fax: +86-755-8427 6832

Email & Skype: info@chipsmall.com Web: www.chipsmall.com

Address: A1208, Overseas Decoration Building, #122 Zhenhua RD., Futian, Shenzhen, China



REVISIONS			
REV	DESCRIPTION, ECN, EAR NO.	DATE	APP'D
C	PRODUCT DRAWING (EAR 13532)	JUN10/09	K.L.

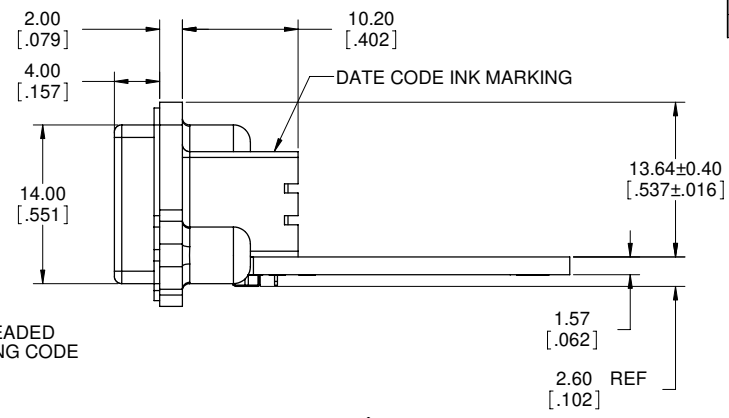
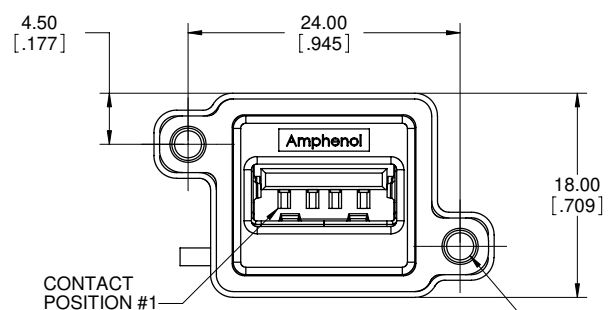

5.50 [.217] DEEP THREADED HOLES. SEE ORDERING CODE THREAD OPTION

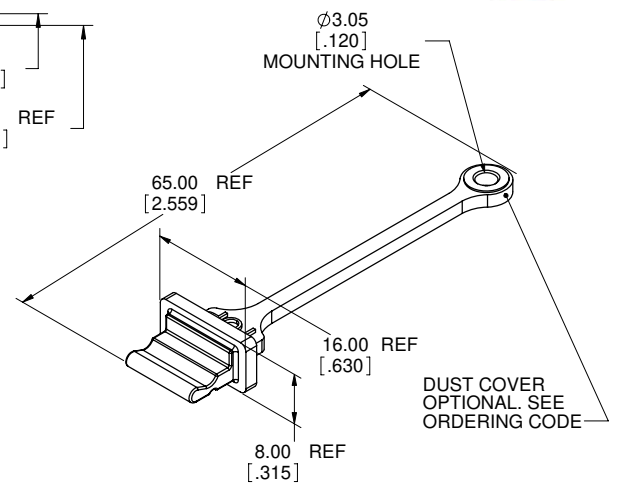
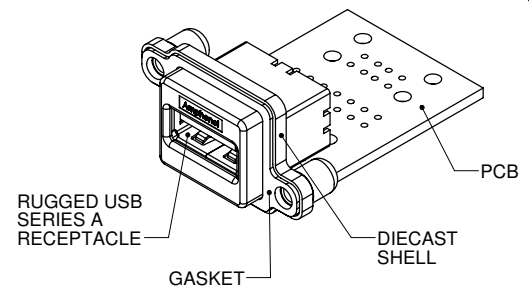
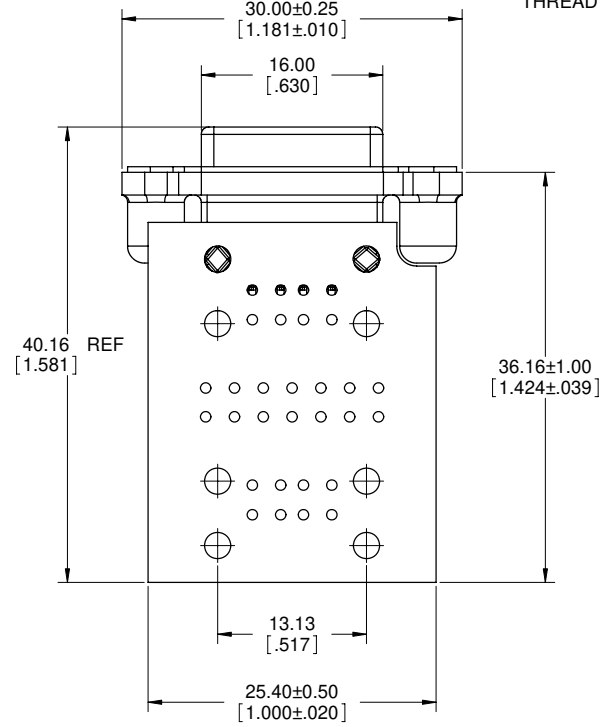

- NOTES:
- MATERIAL:
    - ALL MATERIALS ARE RoHS COMPLIANT PER EU DIRECTIVE 2002/95/EC AND AMENDMENTS.
    - OUTER SHELL - DIECAST ZINC ALLOY, NICKEL PLATED.
    - CONTACTS - PHOSPHOR BRONZE, PLATED WITH 0.76 MICRONS (30 MICROINCHES) GOLD OVER 1.27 MICRONS (50 MICROINCHES) MINIMUM NICKEL ON THE MATING AREA WITH MATTE TIN OVER NICKEL ON THE TAILS.
    - USB HOUSING - ENGINEERING THERMOPLASTIC, HIGH TEMPERATURE RESISTANT, FLAMMABILITY RATING UL94V-0 BLACK.
    - USB SHIELD & BACK COVER - COPPER ALLOY, NICKEL PLATED.
    - GASKET - SILICONE RUBBER, BLACK.
    - PCB - FR-4 FIBERGLASS, LEAD FREE.
    - DUST COVER - SILICONE RUBBER WITH NICKEL PLATED BRASS BUSHING. SEE ORDERING CODE FOR DUST COVER OPTIONS.
  - ENVIRONMENTAL PERFORMANCE PER IEC 60529 CODE IP67 FOR SEAL BETWEEN MATING AREA AND PCB SIDE OF CONNECTOR. GASKET PROVIDES SEAL TO INSIDE FACE OF ENCLOSURE PANEL. AVAILABLE DUST COVER PROVIDES ADDED PROTECTION.
  - CURRENT RATING: 1.5 AMPERES
  - CONTACT RESISTANCE: 50 MILLIOHMS MAXIMUM (SUBJECT TO VERIFICATION)
  - OPERATING TEMPERATURE: -40 °C to +105 °C
  - DUST COVERS MAY BE ORDERED SEPARATELY, SPECIFY
    - MUSB-2A111-014BP FOR GREY DUST COVER
    - MUSB-2A111-024BP FOR BLACK DUST COVER
 SEE SHEET 2 FOR APPLICATION VIEW

ORDERING CODE: M USB - AA 11 - XX

SERIES, RUGGED USB \_\_\_\_\_  
 USB SERIES 'A' RECEPTACLE, RIGHT ANGLE ON PCB WITH HOLES FOR WIRING \_\_\_\_\_  
 THREAD OPTION \_\_\_\_\_  
 3 = #4-40 UNC THREAD  
 M = M3 x 0.5 THREAD \_\_\_\_\_  
 DUST COVER OPTION \_\_\_\_\_  
 0 = NO DUST COVER SUPPLIED  
 1 = WITH GREY DUST COVER SUPPLIED  
 5 = WITH BLACK DUST COVER SUPPLIED

UNLESS SPECIFIED OTHERWISE	DRAWN	S.SEMENOV	FEB28/07
PRIMARY UNITS MILLIMETERS	CHECKED	K.LAMBIE	FEB28/07
SECONDARY UNITS INCHES	M.E. APP'D		
REFERENCE IN PARENTHESES	Q.A. APP'D		
GENERAL TOLERANCES	DWG APPR.	A.GREEN	FEB28/07
1 DECIMAL PLACE	ENG. REL. NO.	EAR 13532	
2 DECIMAL PLACES ±0.15	REF.		
3 DECIMAL PLACES	THIRD ANGLE PROJECTION		
ANGULAR DEGREES	DO NOT SCALE DRAWING		

**Amphenol Canada Corp.**

MUSB RUGGED SERIES A USB RECEPTACLE, RIGHT ANGLE, ON PCB WITH HOLES FOR WIRING THREAD AND DUST COVER OPTIONS, RoHS COMPLIANT

DWG. NO. **P-MUSB-AA11-XX** REV **C**

CODE ID NO. 03554 DWG SIZE: C SCALE: 3:1 SHEET 1 OF 2

REVISIONS			
REV	DESCRIPTION, ECN, EAR NO.	DATE	APP'D
C	PRODUCT DRAWING (EAR 13532)	JUN10/09	K.L.

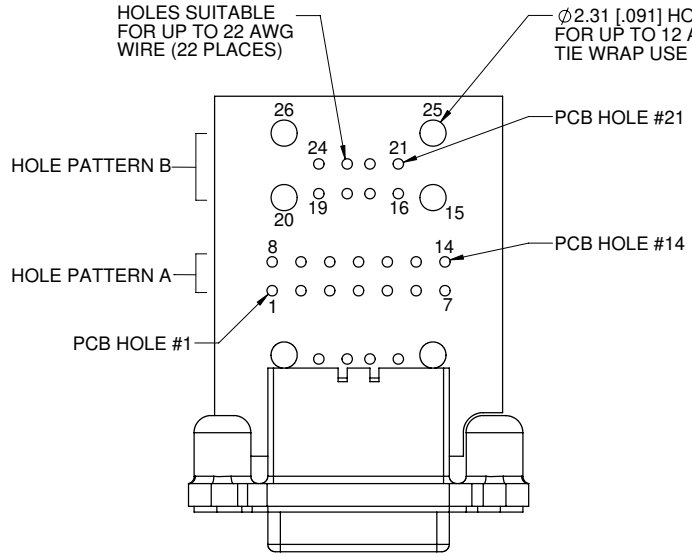

RUGGED USB TO PCB CONNECTION CHART		
RUGGED USB RECEPTACLE	PCB HOLE PATTERN A	PCB HOLE PATTERN B
SHELL/GROUND	HOLE 1	HOLES 15, 20, 25 OR 26
CONTACT 1	HOLE 14	HOLE 21
CONTACT 2	HOLE 13	HOLE 22
CONTACT 3	HOLE 12	HOLE 23
CONTACT 4	HOLE 11	HOLE 24

WIRES MAY BE CONNECTED TO HOLE PATTERN A OR B OR A COMBINATION OF THE TWO PATTERNS

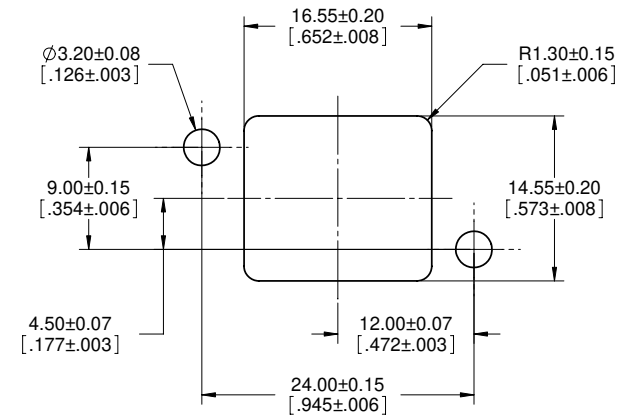

**RECOMMENDED PANEL CUTOUT**  
(OUTSIDE VIEW OF PANEL)

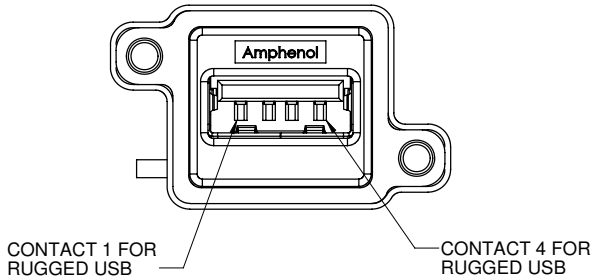

**MUSB CONTACT ASSIGNMENT**

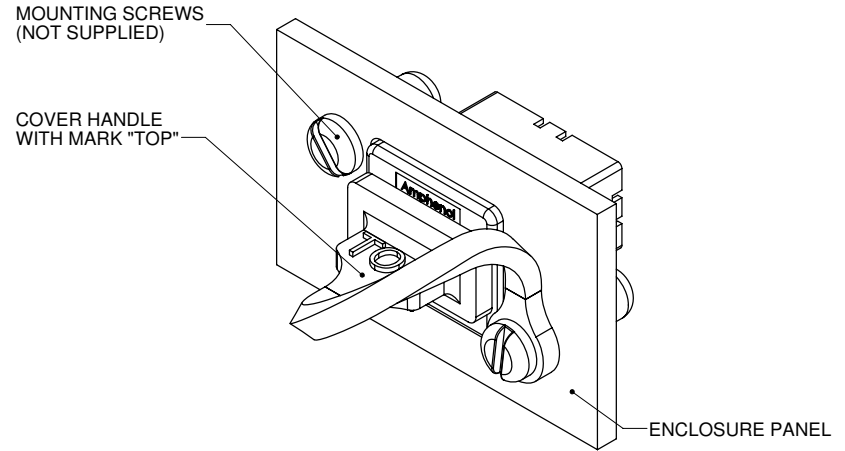

**DUST COVER APPLICATION**



UNLESS SPECIFIED OTHERWISE	DRAWN	S.SEMENOV	FEB28/07
PRIMARY UNITS MILLIMETERS	CHECKED	K.LAMBIE	FEB28/07
SECONDARY INCHES	M.E. APP'D		
REFERENCE IN PARENTHESES	Q.A. APP'D		
GENERAL TOLERANCES	DWG APPR.	A.GREEN	FEB28/07
1 DECIMAL PLACE	ENG. REL. NO.	EAR 13532	
2 DECIMAL PLACES ±0.15	REF.		
3 DECIMAL PLACES	THIRD ANGLE PROJECTION		
ANGULAR DEGREES	DO NOT SCALE DRAWING		

**Amphenol Canada Corp.**

MUSB RUGGED SERIES 'A' USB RECEPTACLE, RIGHT ANGLE, ON PCB WITH HOLES FOR WIRING, THREAD AND DUST COVER OPTIONS, RoHS COMPLIANT

DWG. NO. **P-MUSB-AA11-XX** REV **C**

CODE ID NO. 03554 DWG SIZE: C SCALE: 3:1 SHEET 2 OF 2