



Chipsmall Limited consists of a professional team with an average of over 10 year of expertise in the distribution of electronic components. Based in Hongkong, we have already established firm and mutual-benefit business relationships with customers from,Europe,America and south Asia,supplying obsolete and hard-to-find components to meet their specific needs.

With the principle of "Quality Parts,Customers Priority,Honest Operation,and Considerate Service",our business mainly focus on the distribution of electronic components. Line cards we deal with include Microchip,ALPS,ROHM,Xilinx,Pulse,ON,Everlight and Freescale. Main products comprise IC,Modules,Potentiometer,IC Socket,Relay,Connector.Our parts cover such applications as commercial,industrial, and automotives areas.

We are looking forward to setting up business relationship with you and hope to provide you with the best service and solution. Let us make a better world for our industry!



Contact us

Tel: +86-755-8981 8866 Fax: +86-755-8427 6832

Email & Skype: info@chipsmall.com Web: www.chipsmall.com

Address: A1208, Overseas Decoration Building, #122 Zhenhua RD., Futian, Shenzhen, China



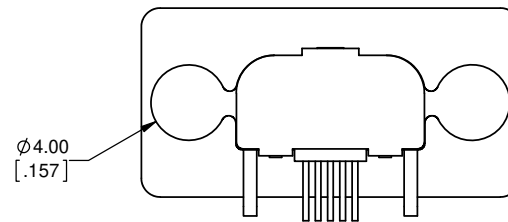
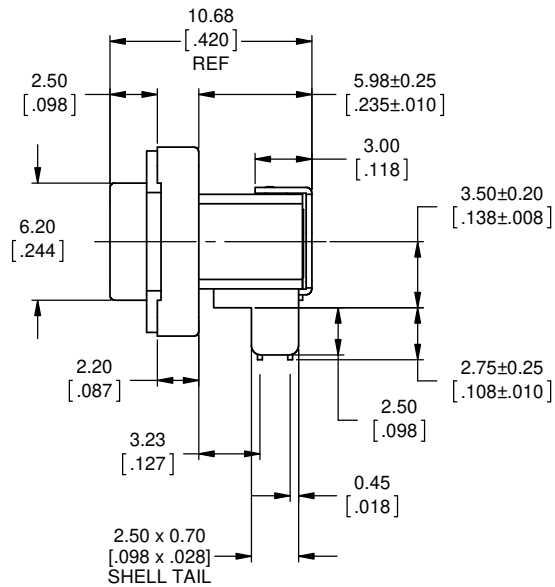
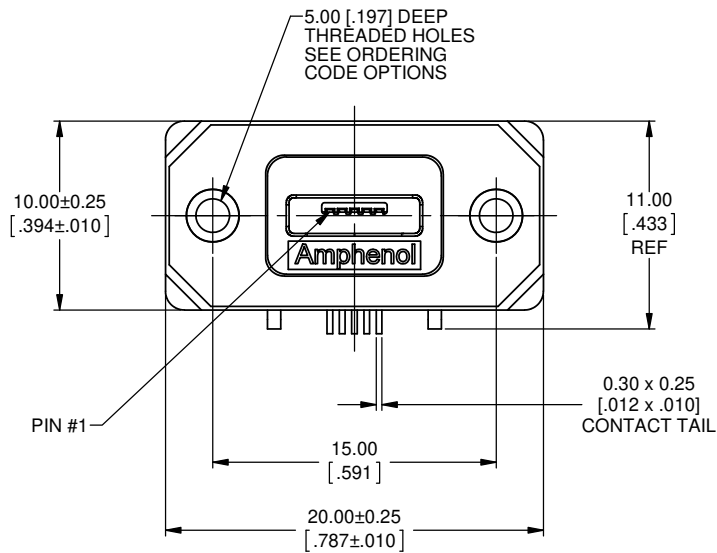

ORDERING CODE: MUSB-K152-XX

SERIES, RUGGED USB
 USB 'MICRO-AB' RECEPTACLE, SINGLE PORT, RIGHT ANGLE PCB TAILS
 THREAD OPTION
 3=#2-56 UNC THREAD
 M= M2.5 X 0.45 THREAD
 DUST COVER OPTION
 0=NO DUST COVER SUPPLIED
 1=WITH GREY DUST COVER SUPPLIED
 5=WITH BLACK DUST COVER SUPPLIED

SPECIAL CONNECTORS:
 MANY UNIQUE FEATURES ARE READILY AVAILABLE TO SUIT CUSTOMER REQUIREMENTS. CONSULT WITH AMPHENOL CANADA FOR DETAILS.

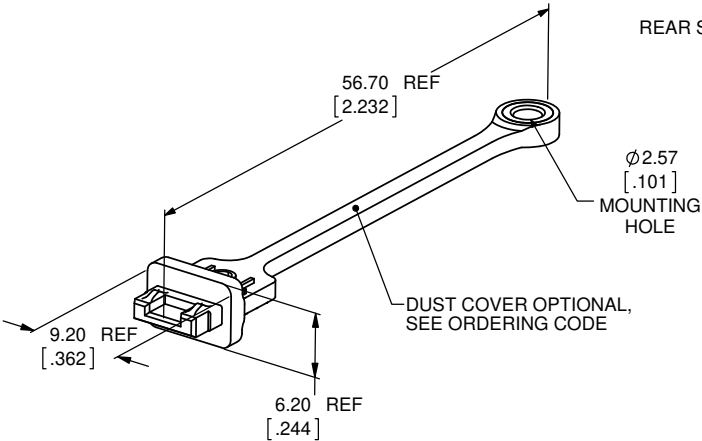
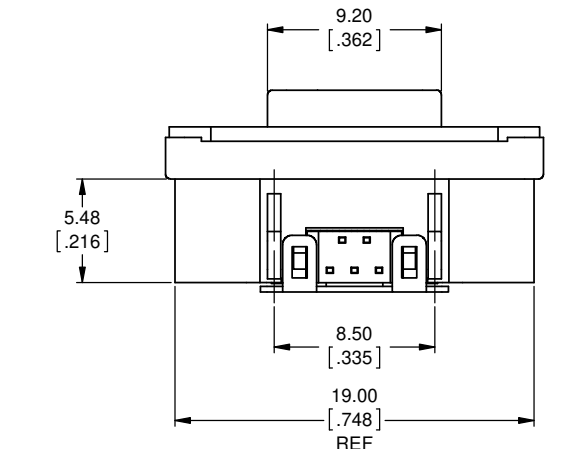
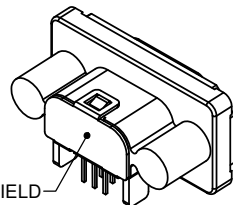
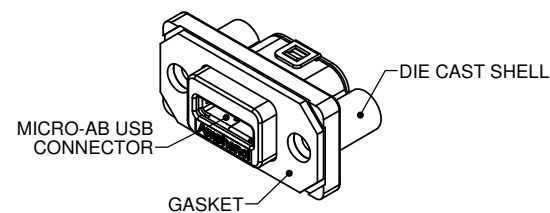

NOTES:

- MATERIAL:**
 ALL MATERIALS ARE RoHS COMPLIANT PER EU DIRECTIVE 2011/65/EU AND AMENDMENTS
 - OUTER SHELL: DIE CAST ZINC ALLOY, NICKEL PLATED
 - CONTACTS: COPPER ALLOY, PLATED WITH 0.76µm [30µ"] GOLD OVER 1.27µm [50µ"] MINIMUM NICKEL ON THE MATING AREA WITH MATTE TIN OVER NICKEL ON THE TAILS.
 - USB HOUSING: ENGINEERING THERMOPLASTIC, FLAMMABILITY RATING UL94V-0, GREY.
 - USB SHELL & REAR SHIELD: STAINLESS STEEL, PASSIVATED.
 - PANEL GASKET: PORON, BLACK.
- ENVIRONMENTAL PERFORMANCE PER IEC 60529 CODE IP67 FOR SEAL BETWEEN MATING AREA & PCB SIDE OF CONNECTOR. GASKET PROVIDES SEAL TO INSIDE FACE OF ENCLOSURE PANEL. AVAILABLE DUST COVER PROVIDES ADDED PROTECTION. SEE SHEET 2 FOR APPLICATION VIEW.**
- CURRENT RATING: 1 A FOR SIGNAL POSITIONS 2, 3 & 4 OR 1.8 A FOR POWER POSITIONS 1 & 5 WITH 0.5 A ON SIGNAL LINES.**
- CONTACT RESISTANCE: 30 MILLIOHMS MAXIMUM.**
- OPERATING TEMPERATURE: -40°C TO +105°C.**
- DUST COVERS MAY BE ORDERED SEPARATELY. SPECIFY**
 - PART NUMBER MUSB-2K15-005BP FOR GREY DUST COVER
 - PART NUMBER MUSB-2K15-015BP FOR BLACK DUST COVER



REVISIONS			
REV	DESCRIPTION, ECN, EAR NO.	DATE	APP'D
E	REV PER EAR 14292	AUG6/14	K.L.
F	REV PER EAR 14388	AUG25/15	K.L.

UNLESS SPECIFIED OTHERWISE	DRAWN	M.SHAH	MAY25/11
PRIMARY UNITS MILLIMETERS	CHECKED	K.LAMBIE	MAY25/11
SECONDARY UNITS INCHES	M.E. APP'D		
REFERENCE IN PARENTHESES	Q.A. APP'D		
GENERAL TOLERANCES	DWG APPR.		
1 DECIMAL PLACE	ENG. REL. NO.	EAR 13873	
2 DECIMAL PLACES ±0.15	REF.		
3 DECIMAL PLACES	THIRD ANGLE PROJECTION		
ANGULAR DEGREES	DO NOT SCALE DRAWING		

Amphenol Canada Corp.
 www.amphenolcanada.com

MUSB SERIES RUGGED MICRO-AB USB RECEPTACLE, RIGHT ANGLE PCB MOUNT, RoHS COMPLIANT

DWG. NO. **P-MUSB-K152-XX** REV **F**

CODE ID NO. 03554 DWG SIZE: X SCALE: 6:1 SHEET 1 OF 2

REVISIONS			
REV	DESCRIPTION, ECN, EAR NO.	DATE	APP'D
E	REV PER EAR 14292	AUG6/14	K.L.
F	REV PER EAR 14388	AUG25/14	K.L.

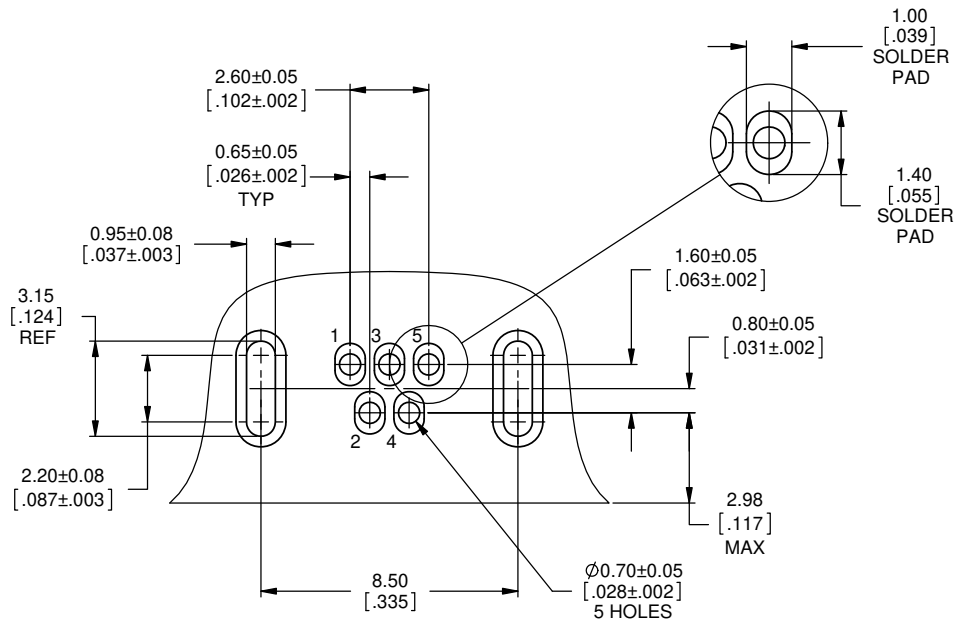

RECOMMENDED P.C.B. LAYOUT
COMPONENT SIDE OF BOARD

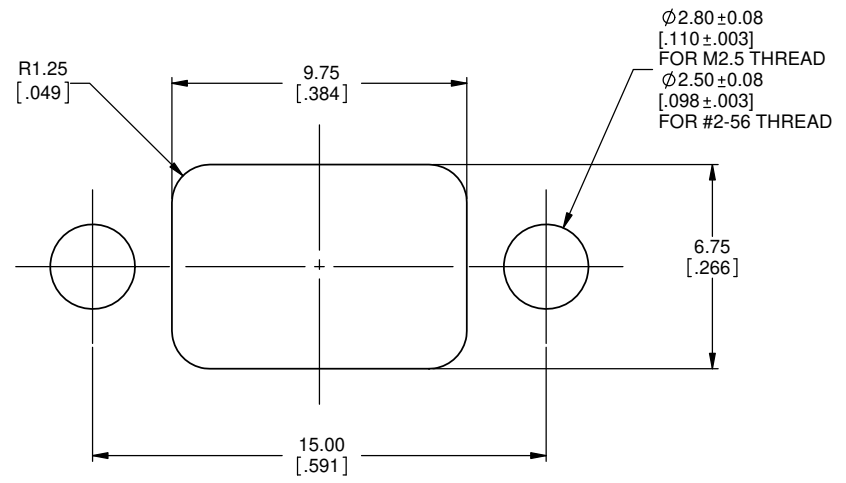

RECOMMENDED PANEL CUTOUT

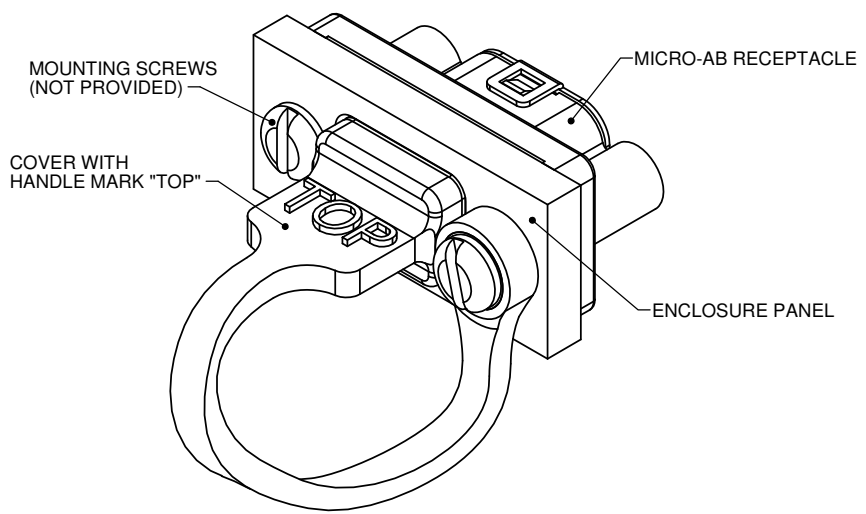

DUST COVER APPLICATION



UNLESS SPECIFIED OTHERWISE	DRAWN	M.SHAH	MAY25/11
PRIMARY UNITS MILLIMETERS	CHECKED	K.LAMBIE	MAY25/11
SECONDARY INCHES	M.E. APP'D		
REFERENCE IN PARENTHESES	Q.A. APP'D		
GENERAL TOLERANCES	DWG APPR.		
1 DECIMAL PLACE	ENG. REL. NO.	EAR 13873	
2 DECIMAL PLACES ±0.15	REF.		
3 DECIMAL PLACES	THIRD ANGLE PROJECTION		
ANGULAR DEGREES	DO NOT SCALE DRAWING		

Amphenol Canada Corp.
www.amphenolcanada.com

MUSB SERIES RUGGED MICRO-AB USB RECEPTACLE, RIGHT ANGLE PCB MOUNT, RoHS COMPLIANT

DWG. NO. **P-MUSB-K152-XX** REV **F**

CODE ID NO. 03554 DWG SIZE: X SCALE: 6:1 SHEET 2 OF 2