



Chipsmall Limited consists of a professional team with an average of over 10 year of expertise in the distribution of electronic components. Based in Hongkong, we have already established firm and mutual-benefit business relationships with customers from,Europe,America and south Asia,supplying obsolete and hard-to-find components to meet their specific needs.

With the principle of “Quality Parts,Customers Priority,Honest Operation,and Considerate Service”,our business mainly focus on the distribution of electronic components. Line cards we deal with include Microchip,ALPS,ROHM,Xilinx,Pulse,ON,Everlight and Freescale. Main products comprise IC,Modules,Potentiometer,IC Socket,Relay,Connector.Our parts cover such applications as commercial,industrial, and automotives areas.

We are looking forward to setting up business relationship with you and hope to provide you with the best service and solution. Let us make a better world for our industry!



## Contact us

Tel: +86-755-8981 8866 Fax: +86-755-8427 6832

Email & Skype: info@chipsmall.com Web: www.chipsmall.com

Address: A1208, Overseas Decoration Building, #122 Zhenhua RD., Futian, Shenzhen, China



# Six-Pack NPT IGBT

$V_{CES} = 1200\text{ V}$   
 $I_{C25} = 125\text{ A}$   
 $V_{CE(sat) typ.} = 2.2\text{ V}$

**Part name** (Marking on product)

MWI 75-12A8

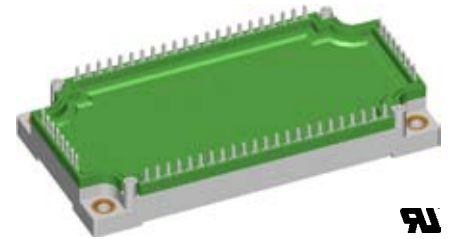
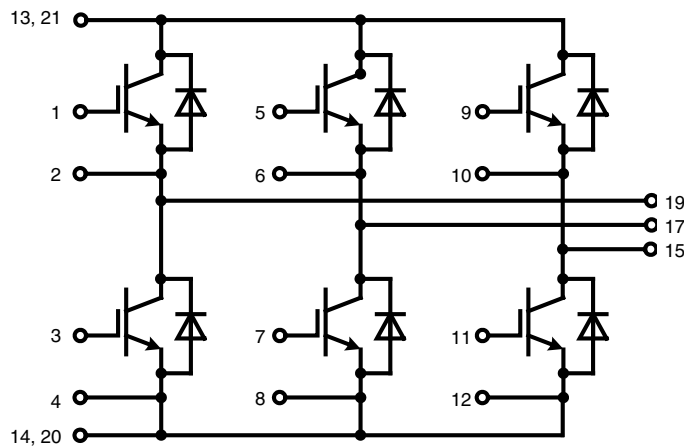

  
 E 72873

Pin configuration see outlines.

### Features:

- NPT IGBT technology
- low saturation voltage
- low switching losses
- switching frequency up to 30 kHz
- square RBSOA, no latch up
- high short circuit capability
- positive temperature coefficient for easy paralleling
- MOS input, voltage controlled
- ultra fast free wheeling diodes
- solderable pins for PCB mounting
- space savings

### Application:

- AC motor control
- AC servo and robot drives
- power supplies

### Package:

- designed for wave soldering
- with copper base plate

**Output Inverter T1 - T6**

Symbol	Definitions	Conditions	Ratings			Unit
			min.	typ.	max.	
$V_{CES}$	collector emitter voltage		$T_{VJ} = 25^{\circ}\text{C}$		1200	V
$V_{GES}$	max. DC gate voltage	continuous			$\pm 20$	V
$V_{GEM}$	max. transient collector gate voltage	transient			$\pm 30$	V
$I_{C25}$	collector current		$T_C = 25^{\circ}\text{C}$		125	A
$I_{C80}$			$T_C = 80^{\circ}\text{C}$		85	A
$P_{tot}$	total power dissipation		$T_C = 25^{\circ}\text{C}$		500	W
$V_{CE(sat)}$	collector emitter saturation voltage	$I_C = 75\text{ A}; V_{GE} = 15\text{ V}$	$T_{VJ} = 25^{\circ}\text{C}$ $T_{VJ} = 125^{\circ}\text{C}$	2.2 2.5	2.6	V V
$V_{GE(th)}$	gate emitter threshold voltage	$I_C = 3\text{ mA}; V_{GE} = V_{CE}$	$T_{VJ} = 25^{\circ}\text{C}$	4.5	6.5	V
$I_{CES}$	collector emitter leakage current	$V_{CE} = V_{CES}; V_{GE} = 0\text{ V}$	$T_{VJ} = 25^{\circ}\text{C}$ $T_{VJ} = 125^{\circ}\text{C}$		5	mA mA
$I_{GES}$	gate emitter leakage current	$V_{GE} = \pm 20\text{ V}$			400	nA
$C_{ies}$	input capacitance	$V_{CE} = 25\text{ V}; V_{GE} = 0\text{ V}; f = 1\text{ MHz}$		5.5		nF
$Q_{G(on)}$	total gate charge	$V_{CE} = 600\text{ V}; V_{GE} = 15\text{ V}; I_C = 75\text{ A}$		350		nC
$t_{d(on)}$	turn-on delay time	inductive load $V_{CE} = 600\text{ V}; I_C = 75\text{ A}$ $V_{GE} = \pm 15\text{ V}; R_G = 15\ \Omega$	$T_{VJ} = 125^{\circ}\text{C}$		100	ns
$t_r$	current rise time				50	ns
$t_{d(off)}$	turn-off delay time				650	ns
$t_f$	current fall time				50	ns
$E_{on}$	turn-on energy per pulse				12.1	mJ
$E_{off}$	turn-off energy per pulse				10.5	mJ
<b>RBSOA</b>	reverse bias safe operating area	$V_{GE} = \pm 15\text{ V}; R_G = 15\ \Omega;$	$T_{VJ} = 125^{\circ}\text{C}$ $V_{CEK} \leq 1200\text{ V}$		150	A
<b>SCSOA</b>	short circuit safe operating area					
$t_{sc}$	short circuit duration	$V_{CE} = 1200\text{ V}; V_{GE} = \pm 15\text{ V};$	$T_{VJ} = 125^{\circ}\text{C}$		10	$\mu\text{s}$
$I_{sc}$	short circuit current	$R_G = 15\ \Omega;$ non-repetitive		300		A
$R_{thJC}$	thermal resistance junction to case	(per IGBT)			0.25	K/W

**Output Inverter D1 - D6**

Symbol	Definitions	Conditions	Ratings			Unit
			min.	typ.	max.	
$V_{RRM}$	max. repetitive reverse voltage		$T_{VJ} = 25^{\circ}\text{C}$		1200	V
$I_{F25}$	forward current		$T_C = 25^{\circ}\text{C}$		150	A
$I_{F80}$			$T_C = 80^{\circ}\text{C}$		100	A
$V_F$	forward voltage	$I_F = 75\text{ A}; V_{GE} = 0\text{ V}$	$T_{VJ} = 25^{\circ}\text{C}$ $T_{VJ} = 125^{\circ}\text{C}$	2.2 1.6	2.6	V V
$I_{RM}$	max. reverse recovery current	$V_R = 600\text{ V}; I_F = 75\text{ A}; V_{GE} = 0\text{ V}$ $di_F/dt = -750\text{ A}/\mu\text{s}$	$T_{VJ} = 125^{\circ}\text{C}$		79	A
$t_{rr}$	reverse recovery time				220	ns
$R_{thJC}$	thermal resistance junction to case	(per diode)			0.41	K/W

**Module**

Symbol	Definitions	Conditions	Ratings			Unit
			min.	typ.	max.	
$T_{VJ}$	operating temperature		-40		125	°C
$T_{VJM}$	max. virtual junction temperature				150	°C
$T_{stg}$	storage temperature		-40		125	°C
$V_{ISOL}$	isolation voltage	$I_{ISOL} \leq 1 \text{ mA}; 50/60 \text{ Hz}$			2500	V~
$M_d$	mounting torque (M5)		3		6	Nm
$d_s$	creep distance on surface		10			mm
$d_A$	strike distance through air		10			mm
$R_{pin-chip}$	resistance pin to chip			1.8		mΩ
$R_{thCH}$	thermal resistance case to heatsink	with heatsink compound		0.01		K/W
<b>Weight</b>				300		g

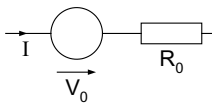
**Equivalent Circuits for Simulation**

Symbol	Definitions	Conditions	min.	Ratings		Unit
				typ.	max.	
$V_0$ $R_0$	IGBT	T1 - T6	$T_{VJ} = 125^\circ\text{C}$	1.5 13.5		V mΩ
$V_0$ $R_0$	Diode	D1 - D6	$T_{VJ} = 125^\circ\text{C}$	1.3 4		V mΩ

### Circuit Diagram

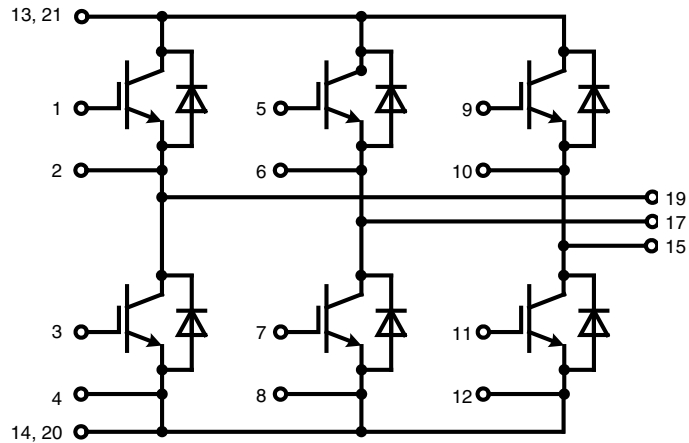

### Outline Drawing

Dimensions in mm (1 mm = 0.0394")

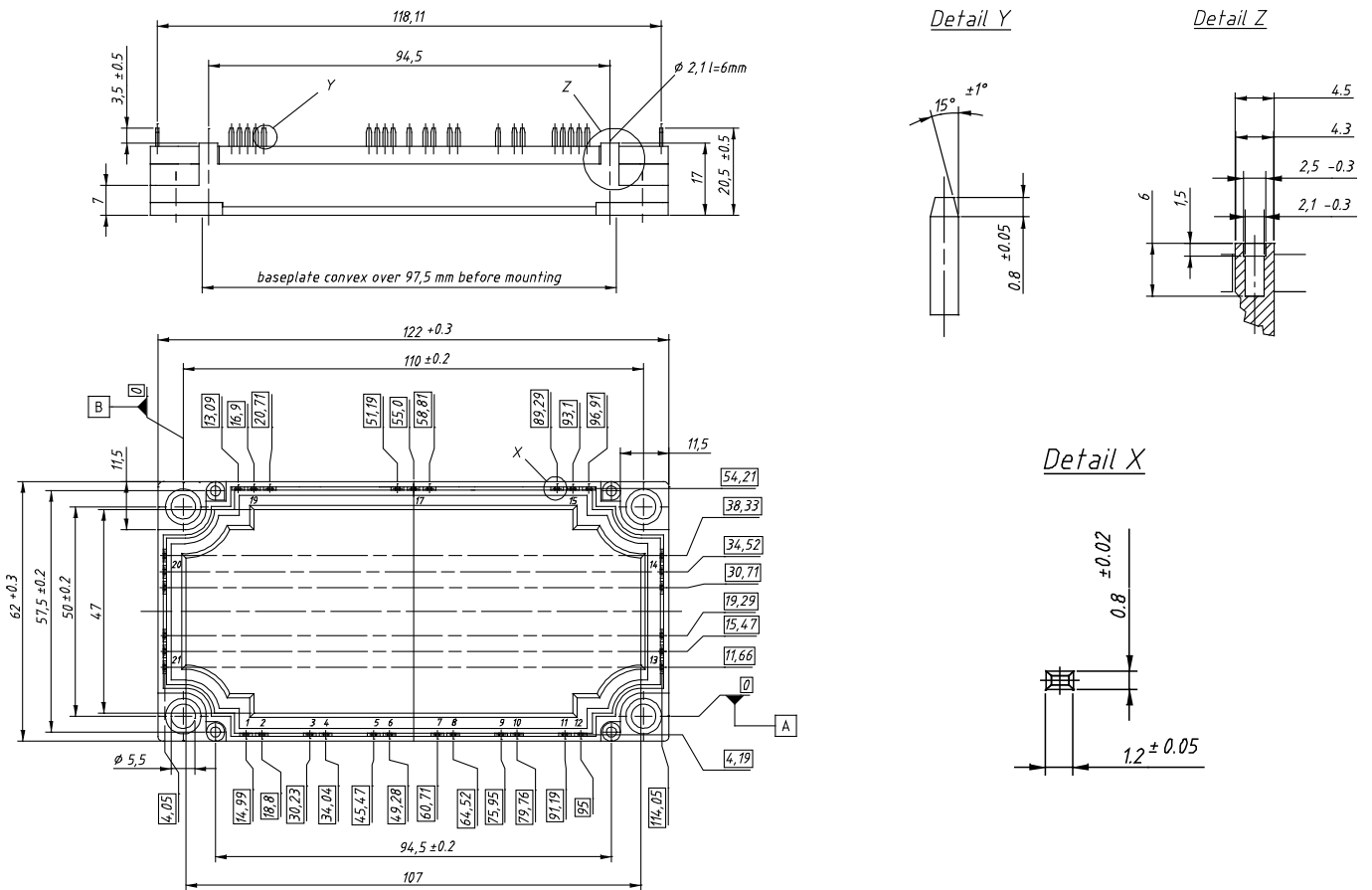

### Product Marking

Ordering	Part Name	Marking on Product	Delivering Mode	Base Qty	Ordering Code
Standard	MWI75-12A8	MWI75-12A8	Box	5	486787

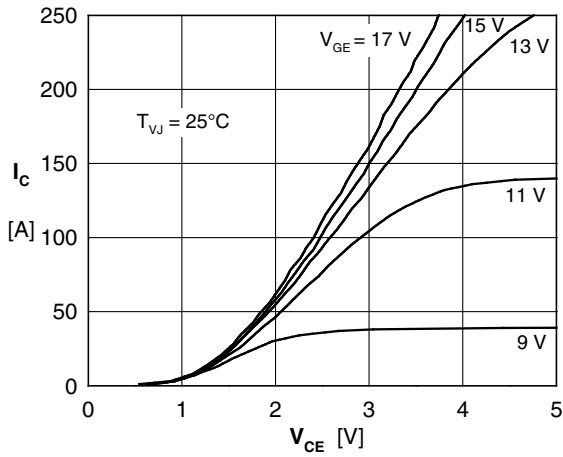

Fig. 1 Typ. output characteristics

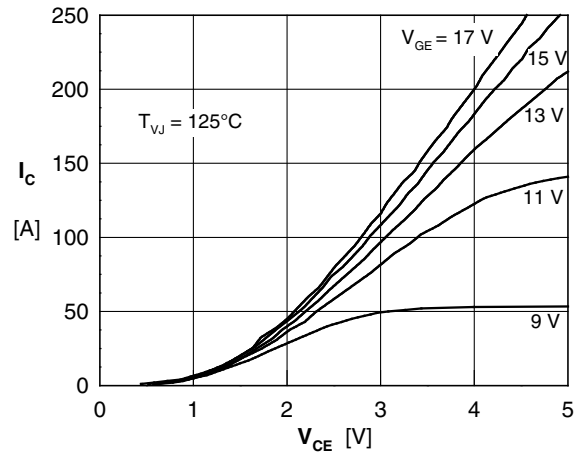

Fig. 2 Typ. output characteristics

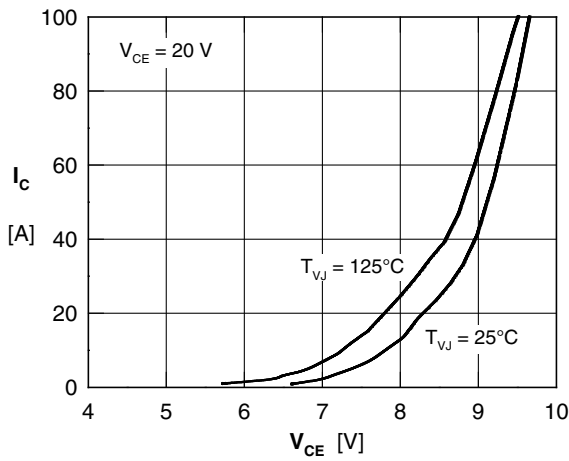

Fig. 3 Typ. transfer characteristics

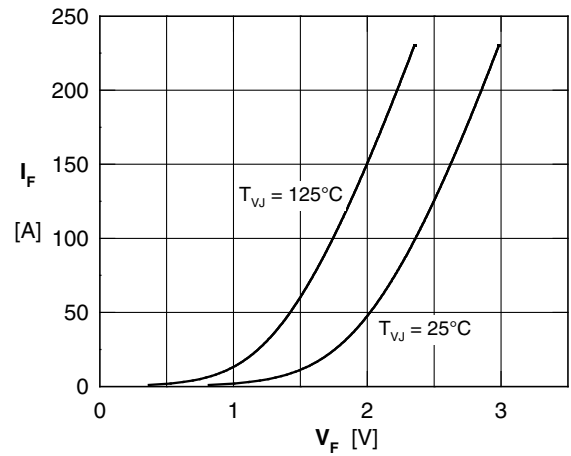

Fig. 4 Typ. forward characteristics of free wheeling diode

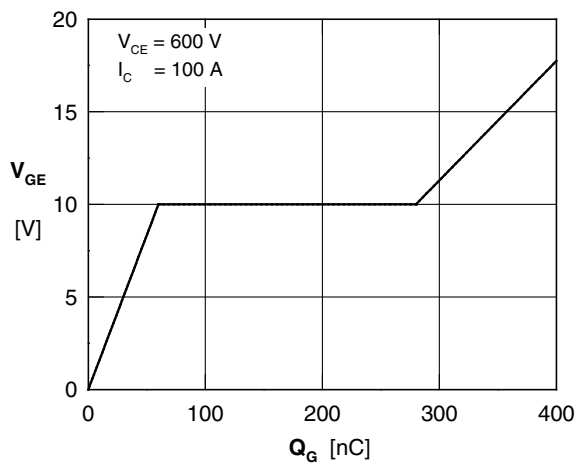

Fig. 5 Typ. turn on gate charge

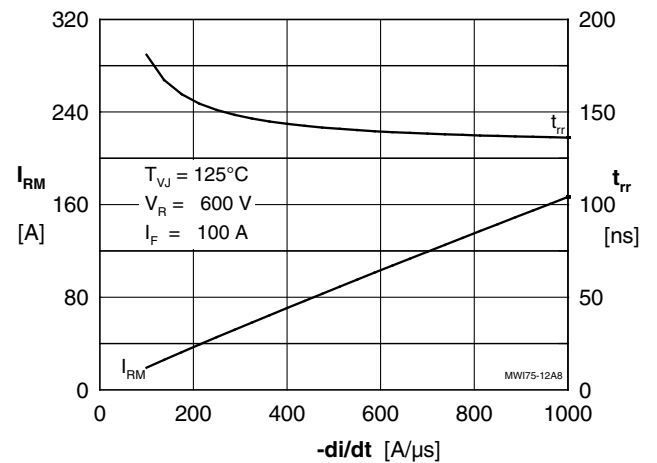

Fig. 6 Typ. turn off characteristics of free wheeling diode

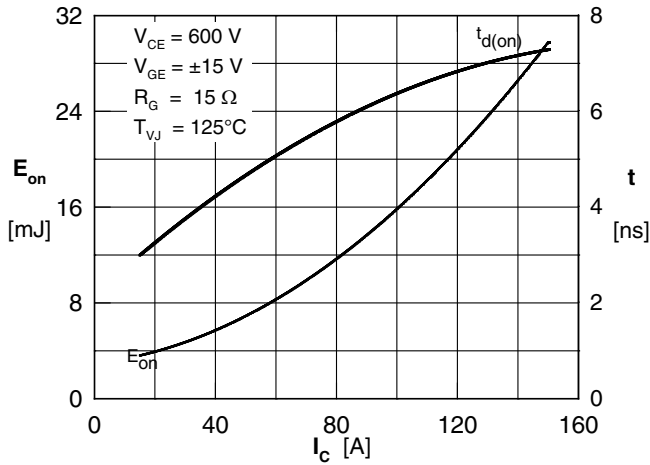

Fig. 7 Typ. turn on energy and switching times versus collector current

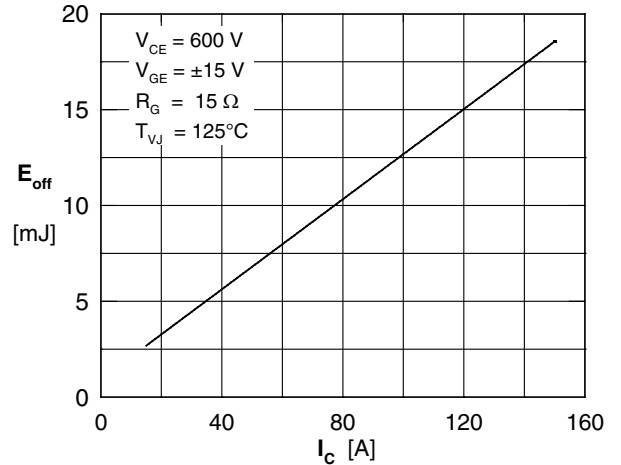

Fig. 8 Typ. turn off energy and switching times versus collector current

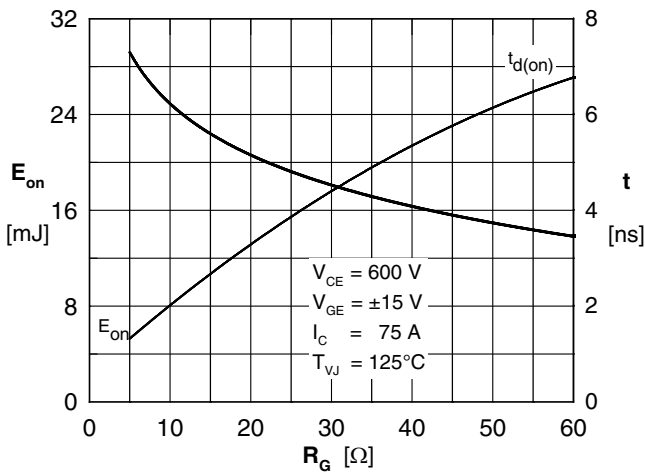

Fig. 9 Typ. turn on energy and switching times versus gate resistor

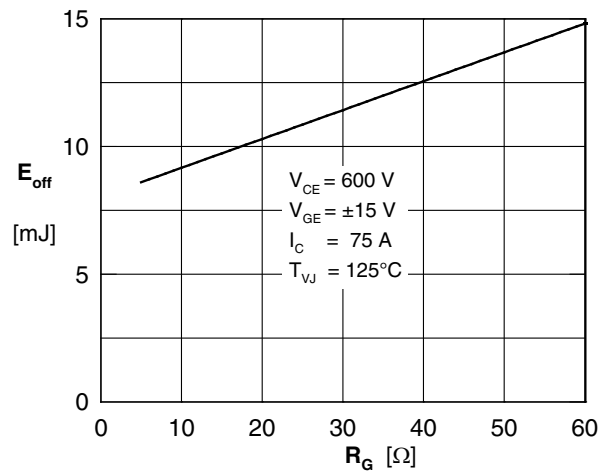

Fig. 10 Typ. turn off energy and switching times versus gate resistor

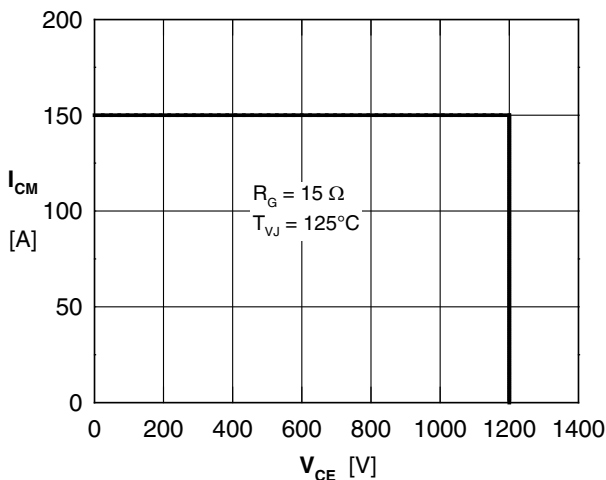

Fig. 11 Reverse biased safe operating area RBSOA

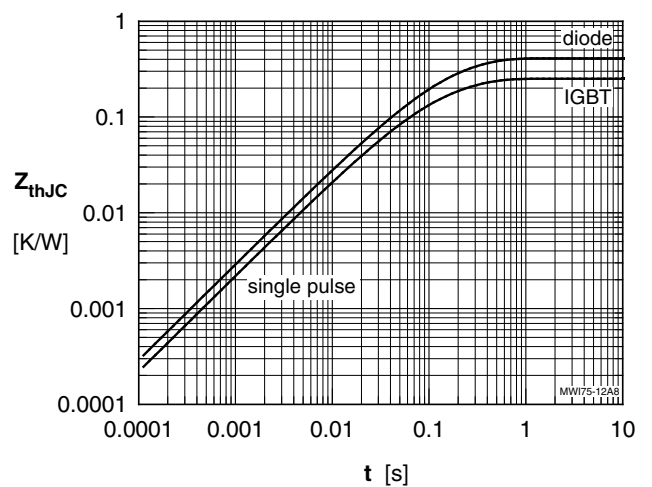

Fig. 12 Typ. transient thermal impedance