



Chipsmall Limited consists of a professional team with an average of over 10 year of expertise in the distribution of electronic components. Based in Hongkong, we have already established firm and mutual-benefit business relationships with customers from,Europe,America and south Asia,supplying obsolete and hard-to-find components to meet their specific needs.

With the principle of “Quality Parts,Customers Priority,Honest Operation,and Considerate Service”,our business mainly focus on the distribution of electronic components. Line cards we deal with include Microchip,ALPS,ROHM,Xilinx,Pulse,ON,Everlight and Freescale. Main products comprise IC,Modules,Potentiometer,IC Socket,Relay,Connector.Our parts cover such applications as commercial,industrial, and automotives areas.

We are looking forward to setting up business relationship with you and hope to provide you with the best service and solution. Let us make a better world for our industry!



## Contact us

Tel: +86-755-8981 8866 Fax: +86-755-8427 6832

Email & Skype: info@chipsmall.com Web: www.chipsmall.com

Address: A1208, Overseas Decoration Building, #122 Zhenhua RD., Futian, Shenzhen, China





MACRONIX  
INTERNATIONAL Co., LTD.

**MX29LV160D T/B**

---

# **MX29LV160D T/B**

## **DATASHEET**

## Contents

<b>FEATURES</b> .....	<b>5</b>
<b>GENERAL DESCRIPTION</b> .....	<b>6</b>
<b>PIN CONFIGURATIONS</b> .....	<b>7</b>
<b>PIN DESCRIPTION</b> .....	<b>9</b>
<b>BLOCK DIAGRAM</b> .....	<b>10</b>
<b>BLOCK DIAGRAM DESCRIPTION</b> .....	<b>11</b>
<b>BLOCK STRUCTURE</b> .....	<b>12</b>
Table 1-1. MX29LV160DT SECTOR ARCHITECTURE .....	12
Table 1-2. MX29LV160DB SECTOR ARCHITECTURE .....	13
<b>BUS OPERATION</b> .....	<b>14</b>
Table 2-1. BUS OPERATION .....	14
Table 2-2. BUS OPERATION .....	15
<b>FUNCTIONAL OPERATION DESCRIPTION</b> .....	<b>16</b>
WRITE COMMANDS/COMMAND SEQUENCES.....	16
REQUIREMENTS FOR READING ARRAY DATA.....	16
RESET# OPERATION .....	17
SECTOR PROTECT OPERATION .....	17
CHIP UNPROTECT OPERATION.....	17
HARDWARE WRITE PROTECT.....	17
ACCELERATED PROGRAMMING OPERATION .....	17
TEMPORARY SECTOR UNPROTECT OPERATION .....	18
AUTOMATIC SELECT OPERATION.....	18
VERIFY SECTOR PROTECT STATUS OPERATION.....	18
DATA PROTECTION.....	18
LOW VCC WRITE INHIBIT .....	18
WRITE PULSE "GLITCH" PROTECTION.....	18
LOGICAL INHIBIT .....	19
POWER-UP SEQUENCE .....	19
POWER-UP WRITE INHIBIT .....	19
POWER SUPPLY DECOUPLING .....	19
<b>COMMAND OPERATIONS</b> .....	<b>20</b>
TABLE 3. MX29LV160D T/B COMMAND DEFINITIONS.....	20
AUTOMATIC PROGRAMMING OF THE MEMORY ARRAY .....	21
ERASING THE MEMORY ARRAY .....	21
SECTOR ERASE .....	22
CHIP ERASE.....	23
SECTOR ERASE SUSPEND.....	23
SECTOR ERASE RESUME.....	24
AUTOMATIC SELECT OPERATIONS .....	24
AUTOMATIC SELECT COMMAND SEQUENCE .....	24

READ MANUFACTURER ID OR DEVICE ID .....	25
VERIFY SECTOR GROUP PROTECTION.....	25
RESET .....	25
<b>COMMON FLASH MEMORY INTERFACE (CFI) MODE .....</b>	<b>26</b>
QUERY COMMAND AND COMMON FLASH INTERFACE (CFI) MODE.....	26
Table 4-1. CFI mode: Identification Data Values .....	26
Table 4-2. CFI Mode: System Interface Data Values .....	26
Table 4-3. CFI Mode: Device Geometry Data Values.....	27
Table 4-4. CFI Mode: Primary Vendor-Specific Extended Query Data Values.....	28
<b>ELECTRICAL CHARACTERISTICS .....</b>	<b>29</b>
ABSOLUTE MAXIMUM STRESS RATINGS.....	29
OPERATING TEMPERATURE AND VOLTAGE.....	29
DC CHARACTERISTICS .....	30
SWITCHING TEST CIRCUIT .....	31
SWITCHING TEST WAVEFORM.....	31
AC CHARACTERISTICS .....	32
<b>WRITE COMMAND OPERATION.....</b>	<b>33</b>
Figure 1. COMMAND WRITE OPERATION.....	33
<b>READ/RESET OPERATION .....</b>	<b>34</b>
Figure 2. READ TIMING WAVEFORM.....	34
Figure 3. RESET# TIMING WAVEFORM.....	35
<b>ERASE/PROGRAM OPERATION .....</b>	<b>36</b>
Figure 4. AUTOMATIC CHIP ERASE TIMING WAVEFORM .....	36
Figure 5. AUTOMATIC CHIP ERASE ALGORITHM FLOWCHART.....	37
Figure 6. AUTOMATIC SECTOR ERASE TIMING WAVEFORM .....	38
Figure 7. AUTOMATIC SECTOR ERASE ALGORITHM FLOWCHART .....	39
Figure 8. ERASE SUSPEND/RESUME FLOWCHART .....	40
Figure 9. AUTOMATIC PROGRAM TIMING WAVEFORM.....	41
Figure 10. ACCELERATED PROGRAM TIMING DIAGRAM .....	41
Figure 11. CE# CONTROLLED WRITE TIMING WAVEFORM.....	42
Figure 12. AUTOMATIC PROGRAMMING ALGORITHM FLOWCHART.....	43
<b>SECTOR PROTECT/CHIP UNPROTECT .....</b>	<b>44</b>
Figure 13. SECTOR PROTECT/CHIP UNPROTECT WAVEFORM (RESET# Control) .....	44
Figure 14. IN-SYSTEM SECTOR PROTECT WITH RESET#=Vhv .....	45
Figure 15. CHIP UNPROTECT ALGORITHMS WITH RESET#=Vhv .....	46
Table 5. TEMPORARY SECTOR UNPROTECT.....	47
Figure 16. TEMPORARY SECTOR UNPROTECT WAVEFORM .....	47
Figure 17. TEMPORARY SECTOR UNPROTECT FLOWCHART.....	48
Figure 18. SILICON ID READ TIMING WAVEFORM.....	49
<b>WRITE OPERATION STATUS.....</b>	<b>50</b>
Figure 19. DATA# POLLING TIMING WAVEFORM (DURING AUTOMATIC ALGORITHM).....	50
Figure 20. DATA# POLLING ALGORITHM .....	51





Figure 21. TOGGLE BIT TIMING WAVEFORM (DURING AUTOMATIC ALGORITHM).....	52
Figure 22. TOGGLE BIT ALGORITHM.....	53
Figure 23. BYTE# TIMING WAVEFORM FOR READ OPERATIONS (BYTE# switching from byte mode to word mode) .....	54
<b>RECOMMENDED OPERATING CONDITIONS.....</b>	<b>55</b>
<b>ERASE AND PROGRAMMING PERFORMANCE .....</b>	<b>56</b>
<b>DATA RETENTION .....</b>	<b>56</b>
<b>LATCH-UP CHARACTERISTICS .....</b>	<b>56</b>
<b>ORDERING INFORMATION .....</b>	<b>57</b>
<b>PART NAME DESCRIPTION .....</b>	<b>58</b>
<b>PACKAGE INFORMATION.....</b>	<b>59</b>
<b>REVISION HISTORY .....</b>	<b>65</b>

## 16M-BIT [2M x 8 / 1M x 16] 3V SUPPLY FLASH MEMORY

### FEATURES

#### GENERAL FEATURES

- Byte/Word mode switchable
  - 2,097,152 x8 / 1,048,576 x16
- Sector Structure
  - 16K-Byte x 1, 8K-Byte x 2, 32K-Byte x 1, 64K-Byte x 31
  - Provides sector protect function to prevent program or erase operation in the protected sector
  - Provides chip unprotect function to allow code changing
  - Provides temporary sector unprotect function for code changing in previously protected sector
- Power Supply Operation
  - Vcc 2.7 to 3.6 volt for read, erase, and program operations
- Latch-up protected to 100mA from -1V to 1.5 x Vcc
- Low Vcc write inhibit : Vcc ≤ Vlko
- Compatible with JEDEC standard
  - Pinout and software compatible to single power supply Flash
- **Functional compatible with MX29LV160C device**

#### PERFORMANCE

- High Performance
  - Fast access time: 70ns
  - Word program time: 11us/word (typical)
  - Fast erase time: 0.7s/sector, 15s/chip (typical)
- Low Power Consumption
  - Low active read current: 5mA (typical) at 5MHz
  - Low standby current: 5uA (typical)
- Typical 100,000 erase/program cycle
- 20 years data retention

#### SOFTWARE FEATURES

- Erase Suspend/ Erase Resume
  - Suspends sector erase operation to read data from or program data to another sector which is not being erased
- Status Reply
  - Data# Polling & Toggle bits provide detection of program and erase operation completion
- Support Common Flash Interface (CFI)

#### HARDWARE FEATURES

- Ready/Busy# (RY/BY#) Output
  - Provides a hardware method of detecting program and erase operation completion
- Hardware Reset (RESET#) Input
  - Provides a hardware method to reset the internal state machine to read mode
- WP#/ACC
  - Provide accelerated program capability

#### PACKAGE

- 48-Pin TSOP
- 48-Ball CSP (TFBGA)
- 48-Ball WFBGA/XFLGA
- **All devices are RoHS Compliant**

## GENERAL DESCRIPTION

MX29LV160DT/B is a 16Mbit flash memory that can be organized as 2Mbytes of 8 bits each or as 1Mwords of 16 bits each. These devices operate over a voltage range of 2.7V to 3.6V typically using a 3V power supply input. The memory array is divided into 32 equal 64 Kilo byte blocks. However, depending on the device being used as a Top-Boot or Bottom-Boot device. The outermost one sector at the top or at the bottom are respectively the boot blocks for this device.

The MX29LV160DT/B is offered in a 48-pin TSOP, 48-ball XFLGA/WFBGA and a 48-ball CSP(TFBGA) JEDEC standard package. These packages are offered in leaded, as well as lead-free versions that are compliant to the RoHS specifications. The software algorithm used for this device also adheres to the JEDEC standard for single power supply devices. These flash parts can be programmed in system or on commercially available EPROM/Flash programmers.

Separate OE# and CE# (Output Enable and Chip Enable) signals are provided to simplify system design. When used with high speed processors, the 70ns read access time of this flash memory permits operation with minimal time lost due to system timing delays.

The automatic write algorithm provided on Macronix flash memories perform an automatic erase prior to write. The user only needs to provide a write command to the command register. The on-chip state machine automatically controls the program and erase functions including all necessary internal timings. Since erase and write operations take much longer time than read operations, erase/write can be interrupted to perform read operations in other sectors of the device. For this, Erase Suspend operation along with Erase Resume operation are provided. Data# polling or Toggle bits are used to indicate the end of the erase/write operation.

These devices are manufactured at the Macronix fabrication facility using the time tested and proven Macronix's advance technology. This proprietary non-epi process provides a very high degree of latch-up protection for stresses up to 100 milliamperes on address and data pins from -1V to 1.5xVCC.

With low power consumption and enhanced hardware and software features, this flash memory retains data reliably for at least twenty years. Erase and programming functions have been tested to meet a typical specification of 100,000 cycles of operation.

## PIN CONFIGURATIONS

### 48 TSOP (Standard Type) (12mm x 20mm)

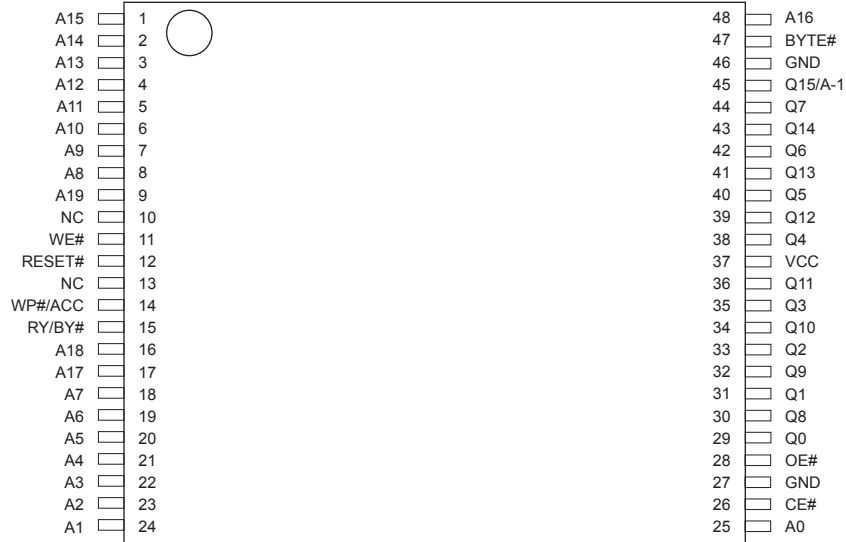

### 48-Ball CSP(TFBGA/LFBGA) (Ball Pitch = 0.8 mm, Top View, Balls Facing Down, 6 x 8 mm)

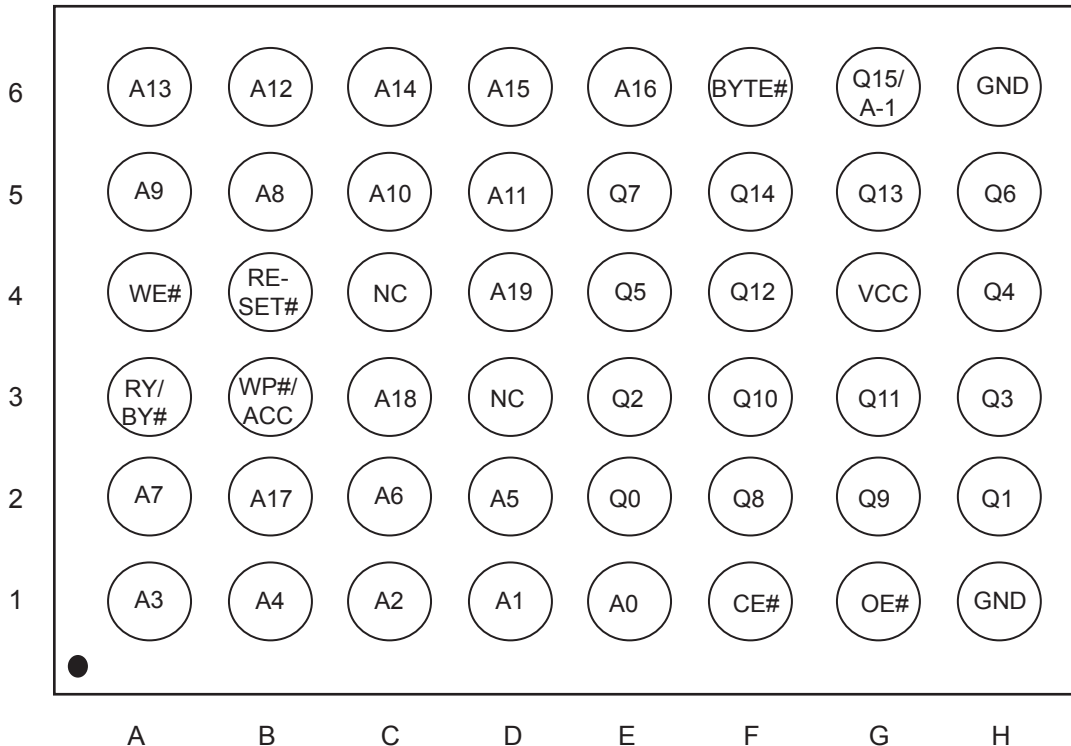



**48-Ball WFBGA (Balls Facing Down, 4 x 6 x 0.75 mm)**

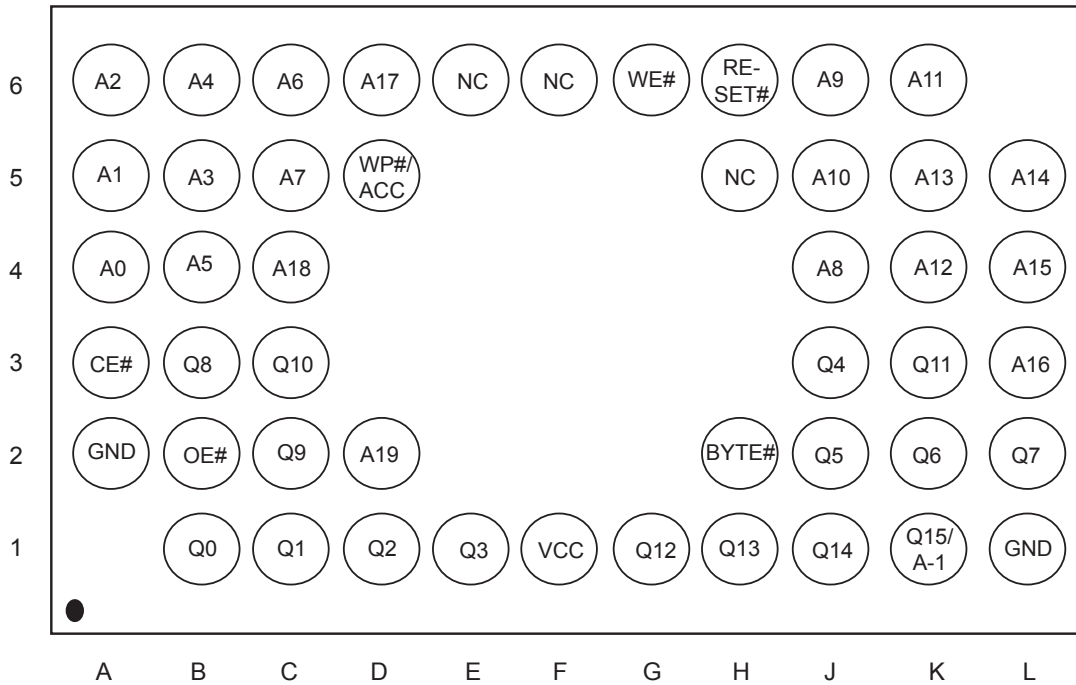

**48-Ball XFLGA (Balls Facing Down, 4 x 6 x 0.5 mm)**

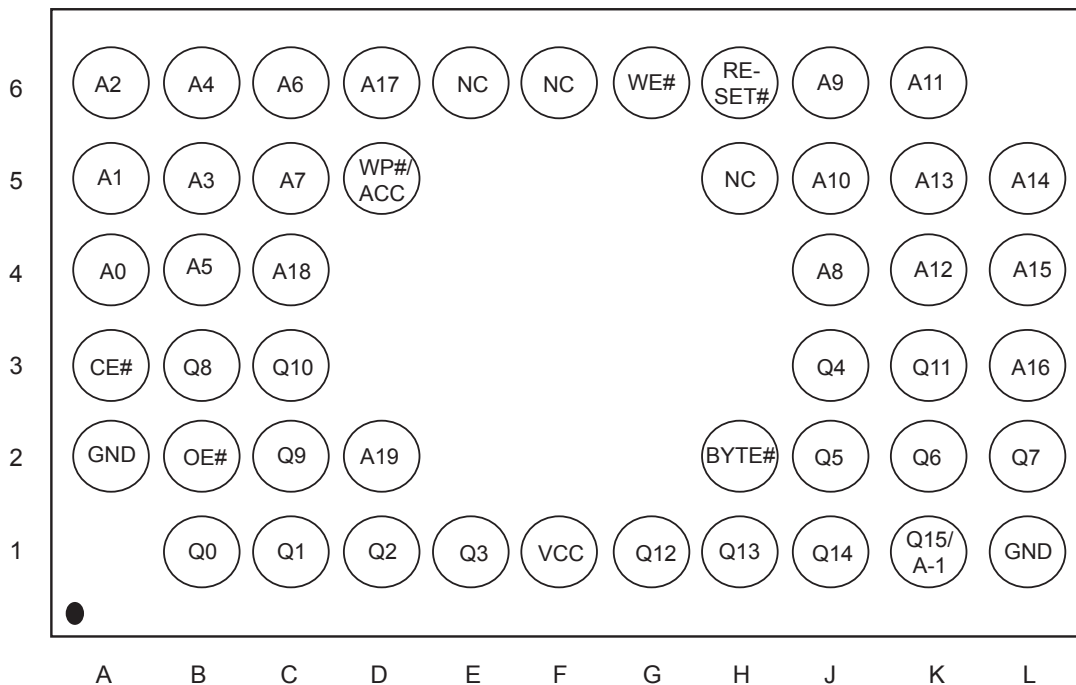

## PIN DESCRIPTION

SYMBOL	PIN NAME
A0~A19	Address Input
Q0~Q14	Data Input/Output
Q15/A-1	Q15(Word mode)/LSB addr(Byte mode)
CE#	Chip Enable Input
WE#	Write Enable Input
BYTE#	Word/Byte Selection input
RESET#	Hardware Reset Pin/Sector Protect Unlock
OE#	Output Enable Input
RY/BY#	Ready/Busy Output
VCC	Power Supply Pin (2.7V~3.6V)
GND	Ground Pin
WP#/ACC	Hardware write Protect/Acceleration Pin
NC	Pin Not Connected Internally

Note: If customer does not need WP#/ACC feature please connect WP#/ACC pin to VCC or let it floating. The WP#/ACC has an internal pull-up when unconnected WP#/ACC is at Vih.

## LOGIC SYMBOL

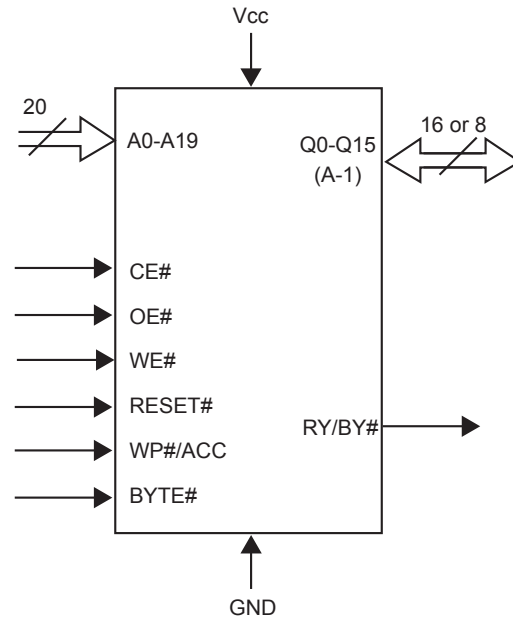

**BLOCK DIAGRAM**

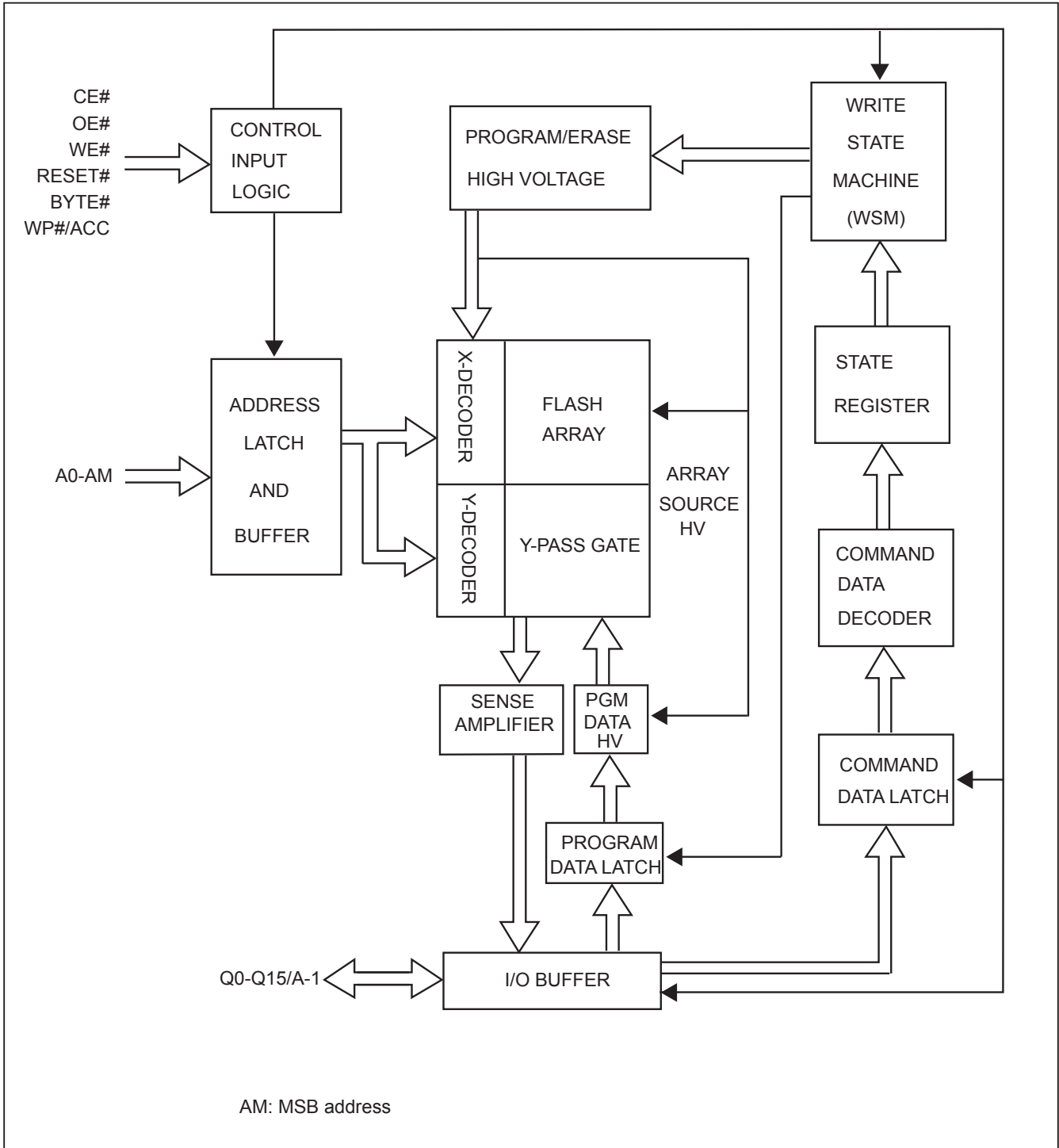

## BLOCK DIAGRAM DESCRIPTION

The block diagram on Page 10 illustrates a simplified architecture of MX29LV160D T/B. Each block in the block diagram represents one or more circuit modules in the real chip used to access, erase, program, and read the memory array.

The "CONTROL INPUT LOGIC" block receives input pins CE#, OE#, WE#, RESET#, BYTE# and WP#/ACC. It creates internal timing control signals according to the input pins and outputs to the "ADDRESS LATCH AND BUFFER" to latch the external address pins A0-AM(A19). The internal addresses are output from this block to the main array and decoders composed of "X-DECODER", "Y-DECODER", "Y-PASS GATE", and "FLASH ARRAY". The X-DECODER decodes the word-lines of the flash array, while the Y-DECODER decodes the bit-lines of the flash array. The bit lines are electrically connected to the "SENSE AMPLIFIER" and "PGM DATA HV" selectively through the y-pass gates. Sense amplifiers are used to read out the contents of the flash memory, while the "PGM DATA HV" block is used to selectively deliver high power to bit-lines during programming. The "I/O BUFFER" controls the input and output on the Q0-Q15/A-1 pads. During read operation, the I/O buffer receives data from sense amplifiers and drives the output pads accordingly. In the last cycle of program command, the I/O buffer transmits the data on Q0-Q15/A-1 to "PROGRAM DATA LATCH", which controls the high power drivers in "PGM DATA HV" to selectively program the bits in a word or byte according to the user input pattern.

The "PROGRAM/ERASE HIGH VOLTAGE" block comprises the circuits to generate and deliver the necessary high voltage to the X-DECODER flash array, and "PGM DATA HV" block. The logic control module comprises of the "WRITE STATE MACHINE(WSM)", "STATE REGISTER", "COMMAND DATA DECODER", and "COMMAND DATA LATCH". When the user issues a command by toggling WE#, the command on Q0-A15/A-1 is latched in the command data latch and is decoded by the command data decoder. The state register receives the command and records the current state of the device. The WSM implements the internal algorithms for program or erase according to the current command state by controlling each block in the block diagram.

## BLOCK STRUCTURE

The main flash memory array can be organized as 2M Bytes x 8 or as 1M Words x 16. The details of the address ranges and the corresponding sector addresses are shown in Table 1. Table 1.a shows the sector architecture for the Top Boot part, whereas Table 1.b shows the sector architecture for the Bottom Boot part. The specific security sector addresses are shown at the bottom off each of these tables.

**Table 1-1. MX29LV160DT SECTOR ARCHITECTURE**

Sector Size		Sector	Sector Address A19-A12	Address Range	
Byte Mode (Kbytes)	Word Mode (Kwords)			Byte Mode (x8)	Word Mode (x16)
64	32	SA0	00000xxx	000000h-00FFFFh	000000h-07FFFh
64	32	SA1	00001xxx	010000h-01FFFFh	008000h-0FFFFh
64	32	SA2	00010xxx	020000h-02FFFFh	010000h-17FFFh
64	32	SA3	00011xxx	030000h-03FFFFh	018000h-01FFFFh
64	32	SA4	00100xxx	040000h-04FFFFh	020000h-027FFFh
64	32	SA5	00101xxx	050000h-05FFFFh	028000h-02FFFFh
64	32	SA6	00110xxx	060000h-06FFFFh	030000h-037FFFh
64	32	SA7	00111xxx	070000h-07FFFFh	038000h-03FFFFh
64	32	SA8	01000xxx	080000h-08FFFFh	040000h-047FFFh
64	32	SA9	01001xxx	090000h-09FFFFh	048000h-04FFFFh
64	32	SA10	01010xxx	0A0000h-0AFFFFh	050000h-057FFFh
64	32	SA11	01011xxx	0B0000h-0BFFFFh	058000h-05FFFFh
64	32	SA12	01100xxx	0C0000h-0CFFFFh	060000h-067FFFh
64	32	SA13	01101xxx	0D0000h-0DFFFFh	068000h-06FFFFh
64	32	SA14	01110xxx	0E0000h-0EFFFFh	070000h-077FFFh
64	32	SA15	01111xxx	0F0000h-0FFFFFh	078000h-07FFFFh
64	32	SA16	10000xxx	100000h-10FFFFh	080000h-087FFFh
64	32	SA17	10001xxx	110000h-11FFFFh	088000h-08FFFFh
64	32	SA18	10010xxx	120000h-12FFFFh	090000h-097FFFh
64	32	SA19	10011xxx	130000h-13FFFFh	098000h-09FFFFh
64	32	SA20	10100xxx	140000h-14FFFFh	0A0000h-0A7FFFh
64	32	SA21	10101xxx	150000h-15FFFFh	0A8000h-0AFFFFh
64	32	SA22	10110xxx	160000h-16FFFFh	0B0000h-0B7FFFh
64	32	SA23	10111xxx	170000h-17FFFFh	0B8000h-0BFFFFh
64	32	SA24	11000xxx	180000h-18FFFFh	0C0000h-0C7FFFh
64	32	SA25	11001xxx	190000h-19FFFFh	0C8000h-0CFFFFh
64	32	SA26	11010xxx	1A0000h-1AFFFFh	0D0000h-0D7FFFh
64	32	SA27	11011xxx	1B0000h-1BFFFFh	0D8000h-0DFFFFh
64	32	SA28	11100xxx	1C0000h-1CFFFFh	0E0000h-0E7FFFh
64	32	SA29	11101xxx	1D0000h-1DFFFFh	0E8000h-0EFFFFh
64	32	SA30	11110xxx	1E0000h-1EFFFFh	0F0000h-0F7FFFh
32	16	SA31	111110xx	1F0000h-1F7FFFh	0F8000h-0FBFFFh
8	4	SA32	11111100	1F8000h-1F9FFFh	0FC000h-0FCFFFh
8	4	SA33	11111101	1FA000h-1FBFFFh	0FD000h-0FDFFFh
16	8	SA34	1111111x	1FC000h-1FFFFFh	0FE000h-0FFFFFh



**Table 1-2. MX29LV160DB SECTOR ARCHITECTURE**

Sector Size		Sector	Sector Address A19-A12	Address Range	
Byte Mode (Kbytes)	Word Mode (Kwords)			Byte Mode (x8)	Word Mode (x16)
16	8	SA0	0000000x	000000h-003FFFh	000000h-001FFFh
8	4	SA1	00000010	004000h-005FFFh	002000h-002FFFh
8	4	SA2	00000011	006000h-007FFFh	003000h-003FFFh
32	16	SA3	000001xx	008000h-00FFFFh	004000h-007FFFh
64	32	SA4	00001xxx	010000h-01FFFFh	008000h-00FFFFh
64	32	SA5	00010xxx	020000h-02FFFFh	010000h-017FFFh
64	32	SA6	00011xxx	030000h-03FFFFh	018000h-01FFFFh
64	32	SA7	00100xxx	040000h-04FFFFh	020000h-027FFFh
64	32	SA8	00101xxx	050000h-05FFFFh	028000h-02FFFFh
64	32	SA9	00110xxx	060000h-06FFFFh	030000h-037FFFh
64	32	SA10	00111xxx	070000h-07FFFFh	038000h-03FFFFh
64	32	SA11	01000xxx	080000h-08FFFFh	040000h-047FFFh
64	32	SA12	01001xxx	090000h-09FFFFh	048000h-04FFFFh
64	32	SA13	01010xxx	0A0000h-0AFFFFh	050000h-057FFFh
64	32	SA14	01011xxx	0B0000h-0BFFFFh	058000h-05FFFFh
64	32	SA15	01100xxx	0C0000h-0CFFFFh	060000h-067FFFh
64	32	SA16	01101xxx	0D0000h-0DFFFFh	068000h-06FFFFh
64	32	SA17	01110xxx	0E0000h-0EFFFFh	070000h-077FFFh
64	32	SA18	01111xxx	0F0000h-0FFFFFh	078000h-07FFFFh
64	32	SA19	10000xxx	100000h-10FFFFh	080000h-087FFFh
64	32	SA20	10001xxx	110000h-11FFFFh	088000h-08FFFFh
64	32	SA21	10010xxx	120000h-12FFFFh	090000h-097FFFh
64	32	SA22	10011xxx	130000h-13FFFFh	098000h-09FFFFh
64	32	SA23	10100xxx	140000h-14FFFFh	0A0000h-0A7FFFh
64	32	SA24	10101xxx	150000h-15FFFFh	0A8000h-0AFFFFh
64	32	SA25	10110xxx	160000h-16FFFFh	0B0000h-0B7FFFh
64	32	SA26	10111xxx	170000h-17FFFFh	0B8000h-0BFFFFh
64	32	SA27	11000xxx	180000h-18FFFFh	0C0000h-0C7FFFh
64	32	SA28	11001xxx	190000h-19FFFFh	0C8000h-0CFFFFh
64	32	SA29	11010xxx	1A0000h-1AFFFFh	0D0000h-0D7FFFh
64	32	SA30	11011xxx	1B0000h-1BFFFFh	0D8000h-0DFFFFh
64	32	SA31	11100xxx	1C0000h-1CFFFFh	0E0000h-0E7FFFh
64	32	SA32	11101xxx	1D0000h-1DFFFFh	0E8000h-0EFFFFh
64	32	SA33	11110xxx	1E0000h-1EFFFFh	0F0000h-0F7FFFh
64	32	SA34	11111xxx	1F0000h-1FFFFFh	0F8000h-0FFFFFh



**BUS OPERATION**

**Table 2-1. BUS OPERATION**

Mode Select	RE-SET#	CE#	WE#	OE#	Address	Data I/O Q7~Q0	Byte#		WP#/ACC
							Vil	Vih	
							Data (I/O) Q15~Q8		
Device Reset	L	X	X	X	X	HighZ	HighZ	HighZ	L/H
Standby Mode	V <sub>cc</sub> ± 0.3V	V <sub>cc</sub> ± 0.3V	X	X	X	HighZ	HighZ	HighZ	H
Output Disable	H	L	H	H	X	HighZ	HighZ	HighZ	L/H
Read Mode	H	L	H	L	AIN	DOUT	Q8-Q14= HighZ, Q15=A-1	DOUT	L/H
Write	H	L	L	H	AIN	DIN		DIN	Note3
Accelerate Program	H	L	L	H	AIN	DIN		DIN	Vhv
Temporary Sector Unprotect	Vhv	X	X	X	AIN	DIN	HighZ	DIN	Note3
Sector Protect (Note2)	Vhv	L	L	H	Sector Address, A6=L, A1=H, A0=L	DIN, DOUT	X	X	L/H
Chip Unprotect (Note2)	Vhv	L	L	H	Sector Address, A6=H, A1=H, A0=L	DIN, DOUT	X	X	Note3

Notes:

1. All sectors will be unprotected if WP#/ACC=Vhv.
2. The one outmost boot sector is protected if WP#/ACC=Vil.
3. When WP#/ACC = Vih, the protection conditions of the one outmost boot sector depend on previous protection conditions."Sector/Sector Block Protection and Unprotection" describes the protect and unprotect method.
4. Q0~Q15 are input (DIN) or output (DOUT) pins according to the requests of command sequence, sector protection, or data polling algorithm.
5. In Word Mode (Byte#=Vih), the addresses are AM to A0.  
In Byte Mode (Byte#=Vil), the addresses are AM to A-1 (Q15).
6. AM: MSB of address.

**Table 2-2. BUS OPERATION**

Item	Control Input			AM to A12	A11 to A10	A9	A8 to A7	A6	A5 to A2	A1	A0	Q7 ~ Q0	Q15 ~ Q8
	CE#	WE#	OE#										
Sector Lock Status Verification	L	H	L	SA	x	V <sub>hv</sub>	x	L	x	H	L	01h or 00h (Note 1)	x
Read Silicon ID Manufacturer Code	L	H	L	x	x	V <sub>hv</sub>	x	L	x	L	L	C2h	x
Read Silicon ID MX29LV160DT	L	H	L	x	x	V <sub>hv</sub>	x	L	x	L	H	C4h	22h(Word)
													x (Byte)
Read Silicon ID MX29LV160DB	L	H	L	x	x	V <sub>hv</sub>	x	L	x	L	H	49h	22h(Word)
													x (Byte)

Notes:

1. Sector unprotected code:00h. Sector protected code:01h.
2. AM: MSB of address.

## FUNCTIONAL OPERATION DESCRIPTION

### WRITE COMMANDS/COMMAND SEQUENCES

To write a command to the device, system must drive WE# and CE# to Vil, and OE# to Vih. In a command cycle, all address are latched at the later falling edge of CE# and WE#, and all data are latched at the earlier rising edge of CE# and WE#.

Figure 1 illustrates the AC timing waveform of a write command, and Table 3 defines all the valid command sets of the device. System is not allowed to write invalid commands not defined in this datasheet. Writing an invalid command will bring the device to an undefined state.

### REQUIREMENTS FOR READING ARRAY DATA

Read array action is to read the data stored in the array. While the memory device is in powered up or has been reset, it will automatically enter the status of read array. If the microprocessor wants to read the data stored in array, it has to drive CE# (device enable control pin) and OE# (Output control pin) as Vil, and input the address of the data to be read into address pin at the same time. After a period of read cycle (Tce or Taa), the data being read out will be displayed on output pin for microprocessor to access. If CE# or OE# is Vih, the output will be in tri-state, and there will be no data displayed on output pin at all.

After the memory device completes embedded operation (automatic Erase or Program), it will automatically return to the status of read array, and the device can read the data in any address in the array. In the process of erasing, if the device receives the Erase suspend command, erase operation will be stopped temporarily after a period of time no more than Tready1 and the device will return to the status of read array. At this time, the device can read the data stored in any address except the sector being erased in the array. In the status of erase suspend, if user wants to read the data in the sectors being erased, the device will output status data onto the output. Similarly, if program command is issued after erase suspend, after program operation is completed, system can still read array data in any address except the sectors to be erased.

The device needs to issue reset command to enable read array operation again in order to arbitrarily read the data in the array in the following two situations:

1. In program or erase operation, the programming or erasing failure causes Q5 to go high.
2. The device is in auto select mode or CFI mode.

In the two situations above, if reset command is not issued, the device is not in read array mode and system must issue reset command before reading array data.

## RESET# OPERATION

Driving RESET# pin low for a period more than  $T_{rp}$  will reset the device back to read mode. If the device is in program or erase operation, the reset operation will take at most a period of  $T_{ready1}$  for the device to return to read array mode. Before the device returns to read array mode, the RY/BY# pin remains low (busy status).

When RESET# pin is held at  $GND \pm 0.3V$ , the device consumes standby current ( $I_{sb}$ ). However, device draws larger current if RESET# pin is held at  $V_{il}$  but not within  $GND \pm 0.3V$ .

It is recommended that the system to tie its reset signal to RESET# pin of flash memory, so that the flash memory will be reset during system reset and allows system to read boot code from flash memory.

## SECTOR PROTECT OPERATION

When a sector is protected, program or erase operation will be disabled on that protected sector. MX29LV160D T/B provides two methods for sector protection.

Once the sector is protected, the sector remains protected until next chip unprotect, or is temporarily unprotected by asserting RESET# pin at  $V_{hv}$ . Refer to temporary sector unprotect operation for further details.

The first method is by applying  $V_{hv}$  on RESET# pin. Refer to Figure 12 for timing diagram and Figure 13 for the algorithm for this method.

The other method is asserting  $V_{hv}$  on A9 and OE# pins, with A6 and CE# at  $V_{il}$ . The protection operation begins at the falling edge of WE# and terminates at the rising edge. Contact Macronix for details.

## CHIP UNPROTECT OPERATION

MX29LV160D T/B provides two methods for chip unprotect. The chip unprotect operation unprotects all sectors within the device. It is recommended to protect all sectors before activating chip unprotect mode. All sectors are unprotected when shipped from the factory.

The first method is by applying  $V_{hv}$  on RESET# pin. Refer to Figure 12 for timing diagram and Figure 14 for algorithm of the operation.

The other method is asserting  $V_{hv}$  on A9 and OE# pins, with A6 at  $V_{ih}$  and CE# at  $V_{il}$ . The unprotect operation begins at the falling edge of WE# and terminates at the rising edge. Contact Macronix for details.

## HARDWARE WRITE PROTECT

By driving the WP#/ACC pin LOW, the outermost one boot sector is protected from all erase/program operations. If WP#/ACC is held HIGH ( $V_{ih}$  to VCC), the one outermost sector revert to its previously protected/unprotected status.

## ACCELERATED PROGRAMMING OPERATION

By applying high voltage ( $V_{hv}$ ) to the WP#/ACC pin, the device will enter the Accelerated Programming mode. This mode permits the system to skip the normal command unlock sequences and program byte/word locations directly. During accelerated programming, the current drawn from the WP#/ACC pin is no more than ICP1.

### TEMPORARY SECTOR UNPROTECT OPERATION

System can apply RESET# pin at V<sub>hv</sub> to place the device in temporary unprotect mode. In this mode, previously protected sectors can be programmed or erased just as it is unprotected. The device returns to normal operation once V<sub>hv</sub> is removed from RESET# pin and previously protected sectors are again protected.

### AUTOMATIC SELECT OPERATION

When the device is in Read array mode, erase-suspended read array mode or CFI mode, user can issue read silicon ID command to enter read silicon ID mode. After entering read silicon ID mode, user can query several silicon IDs continuously and does not need to issue read silicon ID mode again. When A0 is Low, device will output Macronix Manufacture ID C2. When A0 is high, device will output Device ID. In read silicon ID mode, issuing reset command will reset device back to read array mode or erase-suspended read array mode.

Another way to enter read silicon ID is to apply high voltage on A9 pin with CE#, OE#, A6 and A1 at V<sub>il</sub>. While the high voltage of A9 pin is discharged, device will automatically leave read silicon ID mode and go back to read array mode or erase-suspended read array mode. When A0 is Low, device will output Macronix Manufacture ID C2. When A0 is high, device will output Device ID.

### VERIFY SECTOR PROTECT STATUS OPERATION

MX29LV160D T/B provides hardware sector protection against Program and Erase operation for protected sectors. The sector protect status can be read through Sector Protect Verify command. This method requires V<sub>hv</sub> on A9 pin, V<sub>ih</sub> on WE# and A1 pins, V<sub>il</sub> on CE#, OE#, A6 and A0 pins, and sector address on A12 to A<sub>m</sub> pins. If the read out data is 01h, the designated sector is protected. Oppositely, if the read out data is 00h, the designated sector is not protected.

### DATA PROTECTION

To avoid accidental erasure or programming of the device, the device is automatically reset to read array mode during power up. Besides, only after successful completion of the specified command sets will the device begin its erase or program operation.

Other features to protect the data from accidental alternation are described as followed.

### LOW VCC WRITE INHIBIT

The device refuses to accept any write command when V<sub>cc</sub> is less than V<sub>lko</sub>. This prevents data from spuriously altered. The device automatically resets itself when V<sub>cc</sub> is lower than V<sub>lko</sub> and write cycles are ignored until V<sub>cc</sub> is greater than V<sub>lko</sub>. System must provide proper signals on control pins after V<sub>cc</sub> is larger than V<sub>lko</sub> to avoid unintentional program or erase operation

### WRITE PULSE "GLITCH" PROTECTION

CE#, WE#, OE# pulses shorter than 5ns are treated as glitches and will not be regarded as an effective write cycle.



#### **LOGICAL INHIBIT**

A valid write cycle requires both CE# and WE# at Vil with OE# at Vih. Write cycle is ignored when either CE# at Vih, WE# a Vih, or OE# at Vil.

#### **POWER-UP SEQUENCE**

Upon power up, MX29LV160D T/B is placed in read array mode. Furthermore, program or erase operation will begin only after successful completion of specified command sequences.

#### **POWER-UP WRITE INHIBIT**

When WE#, CE# is held at Vil and OE# is held at Vih during power up, the device ignores the first command on the rising edge of WE#.

#### **POWER SUPPLY DECOUPLING**

A 0.1uF capacitor should be connected between the Vcc and GND to reduce the noise effect.



## COMMAND OPERATIONS

**TABLE 3. MX29LV160D T/B COMMAND DEFINITIONS**

Command		Read Mode	Reset Mode	Automatic Select					
				Manufacture ID		Device ID		Sector Protect Verify	
				Word	Byte	Word	Byte	Word	Byte
1st Bus Cycle	Addr	Addr	XXX	555	AAA	555	AAA	555	AAA
	Data	Data	F0	AA	AA	AA	AA	AA	AA
2nd Bus Cycle	Addr			2AA	555	2AA	555	2AA	555
	Data			55	55	55	55	55	55
3rd Bus Cycle	Addr			555	AAA	555	AAA	555	AAA
	Data			90	90	90	90	90	90
4th Bus Cycle	Addr			X00	X00	X01	X02	(Sector)X02	(Sector)X04
	Data			C2h	C2h	ID	ID	00/01	00/01
5th Bus Cycle	Addr								
	Data								
6th Bus Cycle	Addr								
	Data								

Command		Program		Chip Erase		Sector Erase		CFI Read		Erase Suspend	Erase Resume
		Word	Byte	Word	Byte	Word	Byte	Word	Byte	Byte/Word	Byte/Word
1st Bus Cycle	Addr	555	AAA	555	AAA	555	AAA	55	AA	XXX	XXX
	Data	AA	AA	AA	AA	AA	AA	98	98	B0	30
2nd Bus Cycle	Addr	2AA	555	2AA	555	2AA	555				
	Data	55	55	55	55	55	55				
3rd Bus Cycle	Addr	555	AAA	555	AAA	555	AAA				
	Data	A0	A0	80	80	80	80				
4th Bus Cycle	Addr	Addr	Addr	555	AAA	555	AAA				
	Data	Data	Data	AA	AA	AA	AA				
5th Bus Cycle	Addr			2AA	555	2AA	555				
	Data			55	55	55	55				
6th Bus Cycle	Addr			555	AAA	Sector	Sector				
	Data			10	10	30	30				

**Notes:**

1. Device ID : MX29LV160DT: 22C4; MX29LV160DB: 2249.
2. For sector protect verify result, XX00h/00h means sector is not protected, XX01h/01h means sector has been protected.
3. Sector Protect command is valid during V<sub>hv</sub> at RESET# pin, V<sub>ih</sub> at A1 pin and V<sub>il</sub> at A0, A6 pins. The last Bus cyc is for protect verify.
4. It is not allowed to adopt any other code which is not in the above command definition table.

## COMMAND OPERATIONS (cont'd)

### AUTOMATIC PROGRAMMING OF THE MEMORY ARRAY

The MX29LV160D T/B provides the user the ability to program the memory array in Byte mode or Word mode. As long as the users enters the correct cycle defined in the Table 3 (including 2 unlock cycles and the A0h program command), any byte or word data provided on the data lines by the system will automatically be programmed into the array at the specified location.

After the program command sequence has been executed, the internal write state machine (WSM) automatically executes the algorithms and timings necessary for programming and verification, which includes generating suitable program pulses, checking cell threshold voltage margins, and repeating the program pulse if any cells do not pass verification or have low margins. The internal controller protects cells that do pass verification and margin tests from being over-programmed by inhibiting further program pulses to these passing cells as weaker cells continue to be programmed.

With the internal WSM automatically controlling the programming process, the user only needs to enter the program command and data once.

Programming will only change the bit status from "1" to "0". It is not possible to change the bit status from "0" to "1" by programming. This can only be done by an erase operation. Furthermore, the internal write verification only checks and detects errors in cases where a "1" is not successfully programmed to "0".

Any commands written to the device during programming will be ignored except hardware reset, which will terminate the program operation after a period of time no more than Tready1. When the embedded program algorithm is complete or the program operation is terminated by a hardware reset, the device will return to Read mode.

After the embedded program operation has begun, the user can check for completion by reading the following bits in the status register:

Status	Q7	Q6	Q5	RY/BY# *2
In progress *3	Q7#	Toggling	0	0
Finished	Q7	Stop toggling	0	1
Exceed time limit	Q7#	Toggling	1	0

\*1: When an attempt is made to program a protected sector, the program operation will abort thus preventing any data changes in the protected sector. Q7 will output complement data and Q6 will toggle briefly (1us or less) before aborting and returning the device to Read mode.

\*2: RY/BY# is an open drain output pin and should be connected to VCC through a high value pull-up resistor.

\*3: The status "in progress" means both program and erase-suspended program mode.

### ERASING THE MEMORY ARRAY

There are two types of erase operations performed on the memory array -- Sector Erase and Chip Erase. In the Sector Erase operation, one or more selected sectors may be erased simultaneously. In the Chip Erase operation, the complete memory array is erased except for any protected sectors.

**COMMAND OPERATIONS (cont'd)****SECTOR ERASE**

The sector erase operation is used to clear data within a sector by returning all of its memory locations to the "1" state. It requires six command cycles to initiate the erase operation. The first two cycles are "unlock cycles", the third is a configuration cycle, the fourth and fifth are also "unlock cycles", and the sixth cycle is the Sector Erase command. After the sector erase command sequence has been issued, an internal 50us time-out counter is started. Until this counter reaches zero, additional sector addresses and Sector Erase commands may be issued thus allowing multiple sectors to be selected and erased simultaneously. After the 50us time-out counter has expired, no new commands will be accepted and the embedded sector erase operation will begin. Note that the 50us timer-out counter is restarted after every erase command sequence. If the user enters any command other than Sector Erase or Erase Suspend during the time-out period, the erase operation will abort and the device will return to Read mode.

After the embedded sector erase operation begins, all commands except Erase Suspend will be ignored. The only way to interrupt the operation is with an Erase Suspend command or with a hardware reset. The hardware reset will completely abort the operation and return the device to Read mode.

The system can determine the status of the embedded sector erase operation by the following methods:

Status	Q7	Q6	Q5	Q3 (*1)	Q2	RY/BY#(*2)
Time-out period	0	Toggling	0	0	Toggling	0
In progress	0	Toggling	0	1	Toggling	0
Finished	1	Stop toggling	0	1	1	1
Exceeded time limit	0	Toggling	1	1	Toggling	0

**Note :**

- \*1. The Q3 status bit is the time-out indicator. When Q3=0, the time-out counter has not yet reached zero and a new Sector Erase command may be issued to specify the address of another sector to be erased. When Q3=1, the time-out counter has expired and the Sector Erase operation has already begun. Erase Suspend is the only valid command that may be issued once the embedded erase operation is underway.
- \*2. RY/BY# is an open drain output pin and should be connected to VCC through a high value pull-up resistor.
- \*3. When an attempt is made to erase only protected sector(s), the program operation will abort thus preventing any data changes in the protected sector(s). Q7 will output its complement data and Q6 will toggle briefly (100us or less) before aborting and returning the device to Read mode. If unprotected sectors are also specified, however, they will be erased normally and the protected sector(s) will remain unchanged.
- \*4. Q2 is a localized indicator showing a specified sector is undergoing erase operation or not. Q2 toggles when user reads at addresses where the sectors are actively being erased (in erase mode) or to be erased (in erase suspend mode). When a sector has been completely erased, Q2 stops toggling at the sector even when the device is still in erase operation for remaining selected sectors. At that circumstance, Q2 will still toggle when device is read at any other sector that remains to be erased.

## COMMAND OPERATIONS (cont'd)

### CHIP ERASE

The Chip Erase operation is used to erase all the data within the memory array. All memory cells containing a "0" will be returned to the erased state of "1". This operation requires 6 write cycles to initiate the action. The first two cycles are "unlock" cycles, the third is a configuration cycle, the fourth and fifth are also "unlock" cycles, and the sixth cycle initiates the chip erase operation.

During the chip erase operation, no other software commands will be accepted, but if a hardware reset is received or the working voltage is too low, that chip erase will be terminated. After Chip Erase, the chip will automatically return to Read mode.

The system can determine the status of the embedded chip erase operation by the following methods:

Status	Q7	Q6	Q5	Q2	RY/BY# <sup>*1</sup>
In progress	0	Toggling	0	Toggling	0
Finished	1	Stop toggling	0	1	1
Exceed time limit	0	Toggling	1	Toggling	0

\*1: RY/BY# is an open drain output pin and should be connected to VCC through a high value pull-up resistor.

### SECTOR ERASE SUSPEND

After beginning a sector erase operation, Erase Suspend is the only valid command that may be issued. If system issues an Erase Suspend command during the 50us time-out period following a Sector Erase command, the time-out period will terminate immediately and the device will enter Erase-Suspended Read mode. If the system issues an Erase Suspend command after the sector erase operation has already begun, the device will not enter Erase-Suspended Read mode until Tready1 time has elapsed. The system can determine if the device has entered the Erase-Suspended Read mode through Q6, Q7, and RY/BY#.

After the device has entered Erase-Suspended Read mode, the system can read or program any sector(s) except those being erased by the suspended erase operation. Reading any sector being erased or programmed will return the contents of the status register. Whenever a suspend command is issued, user must issue a resume command and check Q6 toggle bit status, before issue another erase command. The system can use the status register bits shown in the following table to determine the current state of the device:

Status	Q7	Q6	Q5	Q3	Q2	RY/BY#
Erase suspend read in erase suspended sector	1	No toggle	0	N/A	Toggle	1
Erase suspend read in non-erase suspended sector	Data	Data	Data	Data	Data	1
Erase suspend program in non-erase suspended sector	Q7#	Toggle	0	N/A	N/A	0

When the device has suspended erasing, user can execute the command sets except sector erase and chip erase, such as read silicon ID, sector protect verify, program, CFI query and erase resume.

**COMMAND OPERATIONS (cont'd)****SECTOR ERASE RESUME**

The sector Erase Resume command is valid only when the device is in Erase-Suspended Read mode. After erase resumes, the user can issue another Erase Suspend command, but there should be a 4ms interval between Erase Resume and the next Erase Suspend command. If the user enters an infinite suspend-resume loop, or suspend-resume exceeds 1024 times, erase times will increase dramatically.

**AUTOMATIC SELECT OPERATIONS**

When the device is in Read mode, Erase-Suspended Read mode, or CFI mode, the user can issue the Automatic Select command shown in Table 3 (two unlock cycles followed by the Automatic Select command 90h) to enter Automatic Select mode. After entering Automatic Select mode, the user can query the Manufacturer ID, Device ID, Security Sector locked status, or Sector-Group protected status multiple times without issuing a new Automatic Select command.

While In Automatic Select mode, issuing a Reset command (F0h) will return the device to Read mode (or Erase-Suspended Read mode if Erase-Suspend was active).

Another way to enter Automatic Select mode is to use one of the bus operations shown in Table 2-2. BUS OPERATION. After the high voltage (V<sub>hv</sub>) is removed from the A9 pin, the device will automatically return to Read mode or Erase-Suspended Read mode.

**AUTOMATIC SELECT COMMAND SEQUENCE**

Automatic Select mode is used to access the manufacturer ID, device ID and to verify whether or not a sector is protected. The automatic select mode has four command cycles. The first two are unlock cycles, and followed by a specific command. The fourth cycle is a normal read cycle, and user can read at any address any number of times without entering another command sequence. The reset command is necessary to exit the Automatic Select mode and back to read array. The following table shows the identification code with corresponding address.

		<b>Address (Hex)</b>	<b>Data (Hex)</b>	<b>Representation</b>
Manufacturer ID	Word	X00	00C2	
	Byte	X00	C2	
Device ID	Word	X01	22C4/2249	Top/Bottom Boot Sector
	Byte	X02	C4/49	Top/Bottom Boot Sector
Sector Protect Verify	Word	(Sector address) X 02	0000/0001	Unprotected/protected
	Byte	(Sector address) X 04	00/01	Unprotected/protected

After entering automatic select mode, no other commands are allowed except the reset command.

## COMMAND OPERATIONS (cont'd)

### READ MANUFACTURER ID OR DEVICE ID

The Manufacturer ID (identification) is a unique hexadecimal number assigned to each manufacturer by the JEDEC committee. Each company has its own manufacturer ID, which is different from the ID of all other companies. The number assigned to Macronix is C2h.

The Device ID is a unique hexadecimal number assigned by the manufacturer for each one of the flash devices made by that manufacturer.

The above two ID types are stored in a 16-bit register on the flash device -- eight bits for each ID. This register is normally read by the user or by the programming machine to identify the manufacturer and the specific device.

After entering Automatic Select mode, performing a read operation with A1 & A0 held LOW will cause the device to output the Manufacturer ID on the Data I/O (Q7 to Q0) pins. Performing a read operation with A1 LOW and A0 HIGH will cause the device to output the Device ID.

### VERIFY SECTOR GROUP PROTECTION

After entering Automatic Select mode, performing a read operation with A1 held HIGH and A0 held LOW and the address of the sector to be checked applied to A19 to A12, data bit Q0 will indicate the protected status of the addressed sector. If Q0 is HIGH, the sector is protected. Conversely, if Q0 is LOW, the sector is unprotected.

### RESET

In the following situations, executing reset command will reset device back to read array mode:

- Among erase command sequence (before the full command set is completed)
- Sector erase time-out period
- Erase fail (while Q5 is high)
- Among program command sequence (before the full command set is completed, erase-suspended program included)
- Program fail (while Q5 is high, and erase-suspended program fail is included)
- Read silicon ID mode
- Sector protect verify
- CFI mode

While device is at the status of program fail or erase fail (Q5 is high), user must issue reset command to reset device back to read array mode. While the device is in read silicon ID mode, sector protect verify or CFI mode, user must issue reset command to reset device back to read array mode.

When the device is in the progress of programming (not program fail) or erasing (not erase fail), device will ignore reset command.