



Chipsmall Limited consists of a professional team with an average of over 10 year of expertise in the distribution of electronic components. Based in Hongkong, we have already established firm and mutual-benefit business relationships with customers from,Europe,America and south Asia,supplying obsolete and hard-to-find components to meet their specific needs.

With the principle of “Quality Parts,Customers Priority,Honest Operation,and Considerate Service”,our business mainly focus on the distribution of electronic components. Line cards we deal with include Microchip,ALPS,ROHM,Xilinx,Pulse,ON,Everlight and Freescale. Main products comprise IC,Modules,Potentiometer,IC Socket,Relay,Connector.Our parts cover such applications as commercial,industrial, and automotives areas.

We are looking forward to setting up business relationship with you and hope to provide you with the best service and solution. Let us make a better world for our industry!



Contact us

Tel: +86-755-8981 8866 Fax: +86-755-8427 6832

Email & Skype: info@chipsmall.com Web: www.chipsmall.com

Address: A1208, Overseas Decoration Building, #122 Zhenhua RD., Futian, Shenzhen, China





Low Profile, Low Consumption, ±2 g Dual Axis Accelerometer with Digital Outputs

MXD6235M

FEATURES

- Low power consumption: typically 2mA @ 3.0V
- RoHS compliant
- Resolution better than 1 mg
- Dual axis accelerometer fabricated on a monolithic CMOS IC
- On chip mixed signal processing
- No moving parts; No loose particle issues
- >50,000 g shock survival rating
- Low profile LCC package: 5mm X 5mm X 1.55mm
- 2.7V to 3.6V single supply continuous operation
- No adjustment needed outside

APPLICATIONS

- Security – Gas Line/Elevator/Fatigue Sensing
- Information Appliances – Computer Peripherals/PDA's/Mouse Smart Pens/Cell Phones
- Gaming – Joystick/RF Interface/Menu Selection/Tilt Sensing
- GPS – electronic Compass tilt Correction
- Consumer – LCD projectors, pedometers, blood pressure Monitor, digital cameras

GENERAL DESCRIPTION

The MXD6235M is a low cost, dual axis accelerometer fabricated on a standard, submicron CMOS process. It is a complete sensing system with on-chip mixed signal processing. The MXD6235M measures acceleration with a full-scale range of ±2 g and a sensitivity of 12.5%/g @3.0V at 25°C. It can measure both dynamic acceleration (e.g. vibration) and static acceleration (e.g. gravity). The MXD6235M design is based on heat convection and requires no solid proof mass. This eliminates stiction and particle problems associated with competitive devices and provides shock survival greater than 50,000 g, leading to significantly lower failure rate and lower loss due to handling during assembly and at customer field application.

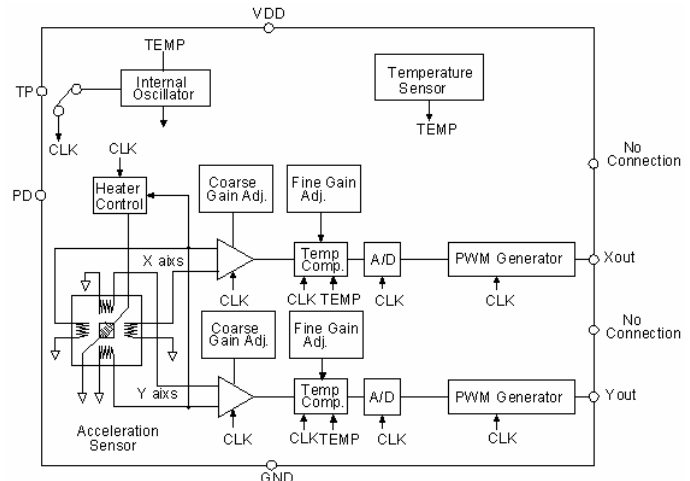

MXD6235M FUNCTIONAL BLOCK DIAGRAM

The MXD6235M provides two digital outputs that are set to 50% duty cycle at zero g acceleration. The outputs are digital with duty cycles (ratio of pulse width to period) that are proportional to acceleration. The duty cycle outputs can be directly interfaced to a microprocessor.

The maximum noise floor is $1 \text{ mg}/\sqrt{\text{Hz}}$ allowing signals below 1mg to be resolved at 1 Hz bandwidth. The MXD6235M is packaged in a hermetically sealed, low profile LCC surface mount package (5 mm x 5 mm x 1.55 mm height). It is operational over a -40°C to 85°C temperature range.

Information furnished by MEMSIC is believed to be accurate and reliable. However, no responsibility is assumed by MEMSIC for its use, nor for any infringements of patents or other rights of third parties which may result from its use. No license is granted by implication or otherwise under any patent or patent rights of MEMSIC.

©MEMSIC, Inc.
One Technology Drive Suite 325, Andover MA 01810, USA
Tel: +1 978 738 0900 Fax: +1 978 738 0196
www.memsic.com

MXD6235M SPECIFICATIONS (Measurements @ 25°C, Acceleration = 0 g unless otherwise noted; V_{DD} = 3.0V unless otherwise specified)

Parameter	Conditions	MXD6235M			Units
		Min	Typ	Max	
SENSOR INPUT	Each Axis				
Measurement Range ¹		±2.0			g
Nonlinearity	Best fit straight line		0.5		% of FS
Alignment Error ²			±1.0		degrees
Transverse Sensitivity ³			±2.0		%
SENSITIVITY	Each Axis				
At outputs	@3.0V supply	11.8	12.5	13.2	% duty cycle/g
Change over Temperature				20	%
ZERO g BIAS LEVEL	Each Axis				
0 g Offset		-0.1	0.0	+0.1	g
0 g Duty Cycle		48.7	50	51.3	% duty cycle
0 g Offset over Temperature	Based on 20%/g		1.5 0.0225		mg/°C %/°C
PWM Frequency		95 380	100 400	105 420	Hz Hz
NOISE PERFORMANCE					
Noise Density, rms			0.4	1.0	mg/ $\sqrt{\text{Hz}}$
FREQUENCY RESPONSE					
3dB Bandwidth		15	17	19	Hz
SELF TEST					
Continuous Voltage at outputs under failure	@3.0V Supply, output rails to supply voltage		3.0		V
OUTPUTS PERFORMANCE					
Normal Output Range	Output High	2.8			V
	Output Low			0.2	V
Current	Source or sink, @ 2.7V-3.6V supply			100	µA
Rise/Fall Time	2.7 to 3.6V supply	90	100	110	nS
Turn-On Time ⁴	@3.0V Supply		75		mS
POWER SUPPLY					
Operating Voltage Range		2.7	3.0	3.6	V
Supply Current	@ 3.0 V		2.0		mA
TEMPERATURE RANGE					
Operating Range		-40		+85	°C

NOTES

¹ Guaranteed by measurement of initial offset and sensitivity.

² Alignment error is specified as the angle between the true and indicated axis of sensitivity.

³ Cross axis sensitivity is the algebraic sum of the alignment and the inherent sensitivity errors.

⁴ Output settled to within ±17mg.

ABSOLUTE MAXIMUM RATINGS*

Supply Voltage (V_{DD})-0.5 to +7.0V
 Storage Temperature-65°C to +150°C
 Acceleration50,000 g

*Stresses above those listed under Absolute Maximum Ratings may cause permanent damage to the device. This is a stress rating only; the functional operation of the device at these or any other conditions above those indicated in the operational sections of this specification is not implied. Exposure to absolute maximum rating conditions for extended periods may affect device reliability.

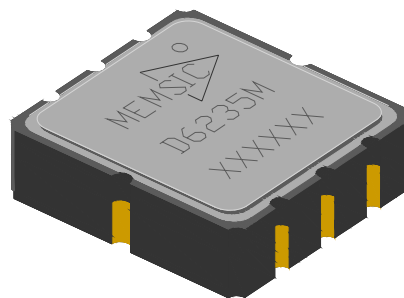

Pin Description: LCC-8 Package

Pin	Name	Description	I/O
1	PD	Power down pin	I
2	TP	Connected to ground	I
3	GND	Connected to ground	I
4	NC	Do Not Connect	NC
5	NC	Do Not Connect	NC
6	Yout	Y Channel Duty Cycle Output	O
7	Xout	X Channel Duty Cycle Output	O
8	V _{DD}	2.7V to 3.6 V	I

Ordering Guide

Model	Package Type	PWM Frequency	Temperature Range
MXD6235MP	LCC8 RoHS compliant	100Hz	-40 to 85°C

All parts are shipped in tape and reel packaging.

Caution: ESD (electrostatic discharge) sensitive device.

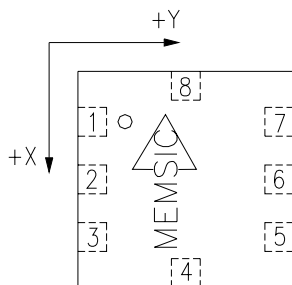

Top View
(Not to Scale)

Note: The MEMSIC logo's arrow indicates the -X sensing direction of the device. The +Y sensing direction is rotated 90° away from the +X direction following the right-hand rule. Small circle indicates pin one (1).

THEORY OF OPERATION

The MEMSIC device is a complete dual-axis acceleration measurement system fabricated on a monolithic CMOS IC process. The device operation is based on heat transfer by natural convection and operates like other accelerometers having a proof mass except it is a gas in the MEMSIC sensor.

A single heat source, centered in the silicon chip is suspended across a cavity. Equally spaced aluminum/polysilicon thermopiles (groups of thermocouples) are located equidistantly on all four sides of the heat source (dual axis). Under zero acceleration, a temperature gradient is symmetrical about the heat source, so that the temperature is the same at all four thermopiles, causing them to output the same voltage.

Acceleration in any direction will disturb the temperature profile, due to free convection heat transfer, causing it to be asymmetrical. The temperature, and hence voltage output of the four thermopiles will then be different. The differential voltage at the thermopile outputs is directly proportional to the acceleration. There are two identical acceleration signal paths on the accelerometer, one to measure acceleration in the x-axis and one to measure acceleration in the y-axis. Please visit the MEMSIC website at www.memsic.com for a picture/graphic description of the free convection heat transfer principle.

PIN DESCRIPTIONS

V_{DD} – This is the supply input for the circuits and the sensor heater in the accelerometer. The DC voltage should be between 2.7 and 3.6 volts. Refer to the section on PCB layout and fabrication suggestions for guidance on external parts and connections recommended.

GND– This is the ground pin for the accelerometer.

TP– This pin should be connected to ground.

Xout – This pin is the digital output of the X-axis acceleration sensor. The user should ensure the load impedance is sufficiently high as to not source/sink >100µA typical.

Yout – This pin is the digital output of the Y-axis acceleration sensor. The user should ensure the load impedance is sufficiently high as to not source/sink >100µA typical.

PD – Pin1 is the power down control pin. Pull this pin HIGH will put the accelerometer into power down mode. When the part does into power down mode, the total current will be smaller than 0.1uA at 3V.

In normal operation mode, this pin should be connected to Ground.

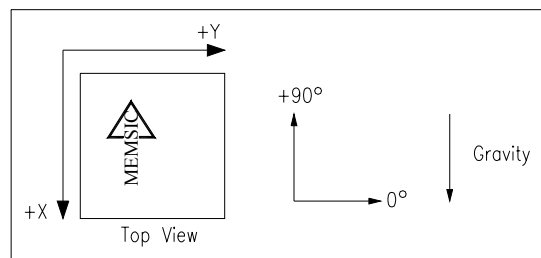

Accelerometer Position Relative to Gravity

X-Axis Orientation To Earth's Surface (deg.)	X-Axis		Y-Axis	
	X Output (g)	Change per deg. of tilt (mg)	Y Output (g)	Change per deg. of tilt (mg)
90	1.000	0.15	0.000	17.45
85	0.996	1.37	0.087	17.37
80	0.985	2.88	0.174	17.16
70	0.940	5.86	0.342	16.35
60	0.866	8.59	0.500	15.04
45	0.707	12.23	0.707	12.23
30	0.500	15.04	0.866	8.59
20	0.342	16.35	0.940	5.86
10	0.174	17.16	0.985	2.88
5	0.087	17.37	0.996	1.37
0	0.000	17.45	1.000	0.15

Changes in Tilt for X- and Y-Axes

DISCUSSION OF TILT APPLICATIONS AND RESOLUTION

Tilt Applications: One of the most popular applications of the MEMSIC accelerometer product line is in tilt/inclination measurement. An accelerometer uses the force of gravity as an input to determine the inclination angle of an object.

A MEMSIC accelerometer is most sensitive to changes in position, or tilt, when the accelerometer's sensitive axis is perpendicular to the force of gravity, or parallel to the Earth's surface. Similarly, when the accelerometer's axis is parallel to the force of gravity (perpendicular to the Earth's surface), it is least sensitive to changes in tilt.

Following table and figure help illustrate the output changes in the X- and Y-axes as the unit is tilted from +90° to 0°. Notice that when one axis has a small change in output per degree of tilt (in mg), the second axis has a large change in output per degree of tilt. The complementary nature of these two signals permits low cost accurate tilt sensing to be achieved with the MEMSIC device (reference application note AN-00MX-007).

Resolution: The accelerometer resolution is limited by noise. The output noise will vary with the measurement bandwidth. With the reduction of the bandwidth, by applying an external low pass filter, the output noise drops. Reduction of bandwidth will improve the signal to noise ratio and the resolution. The output noise scales directly with the square root of the measurement bandwidth. The maximum amplitude of the noise, its peak- to- peak value, approximately defines the worst case resolution of the measurement. With a simple RC low pass filter, the rms noise is calculated as follows:

$$\text{Noise (mg rms)} = \text{Noise(mg}/\sqrt{\text{Hz}}) * \sqrt{(\text{Bandwidth(Hz)} * 1.6)}$$

The peak-to-peak noise is approximately equal to 6.6 times the rms value (for an average uncertainty of 0.1%).

DIGITAL INTERFACE

The MXD6235M is easily interfaced with low cost microcontroller. For the digital output accelerometer, one digital input port is required to read one accelerometer output.

In many applications the microcontroller provides an effective approach for the temperature compensation of the sensitivity and the zero g offset. Specific code set, reference designs, and applications notes are available from the factory. The following parameters must be considered in a digital interface:

Resolution: smallest detectable change in input acceleration

Bandwidth: detectable accelerations in a given period of time

Acquisition Time: the duration of the measurement of the acceleration signal

DUTY CYCLE DEFINITION

The MXD6235M has two PWM duty cycle outputs (x,y). The acceleration is proportional to the ratio T1/T2. The zero g output is set to 50% duty cycle and the sensitivity scale factor is set to 12.5% duty cycle change per g. These nominal values are affected by the initial tolerance of the device including zero g offset error and sensitivity error. This device is offered from the factory programmed to 10ms period (100 Hz).

T1	Length of the “on” portion of the cycle.
T2 (Period)	Length of the total cycle.
Duty Cycle	Ratio of the “on” time (T1) of the cycle to the total cycle (T2). Defined as T1/T2.
Pulse width	Time period of the “on” pulse. Defined as T1.

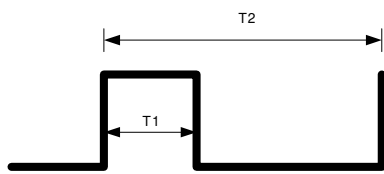

$$A (g) = (T1/T2 - 0.5) / 0.125$$

At 0g T1=T2
T2= 10ms
Typical output Duty Cycle

POWER SUPPLY NOISE REJECTION

One capacitor is recommended for best rejection of power supply noise (reference figure below). The capacitor should

be located as close as possible to the device supply pin (V_{DD}). The capacitor lead length should be as short as possible, and surface mount capacitor is preferred. For typical applications, the capacitor can be ceramic 0.1 μF.

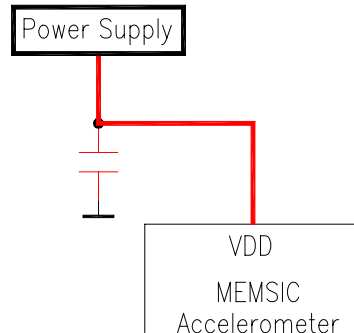

Power Supply Noise Rejection

PCB LAYOUT AND FABRICATION SUGGESTIONS

1. It is best to solder a 0.1μF capacitor directly across V_{DD} and COM pin.
2. Robust low inductance ground wiring should be used.
3. Care should be taken to ensure there is “thermal symmetry” on the PCB immediately surrounding the MEMSIC device and that there is no significant heat source nearby.
4. A metal ground plane should be added directly beneath the MEMSIC device. The size of the plane should be similar to the MEMSIC device’s footprint and be as thick as possible.
5. Vias can be added symmetrically around the ground plane. Vias increase thermal isolation of the device from the rest of the PCB.

LCC-8 PACKAGE DRAWING

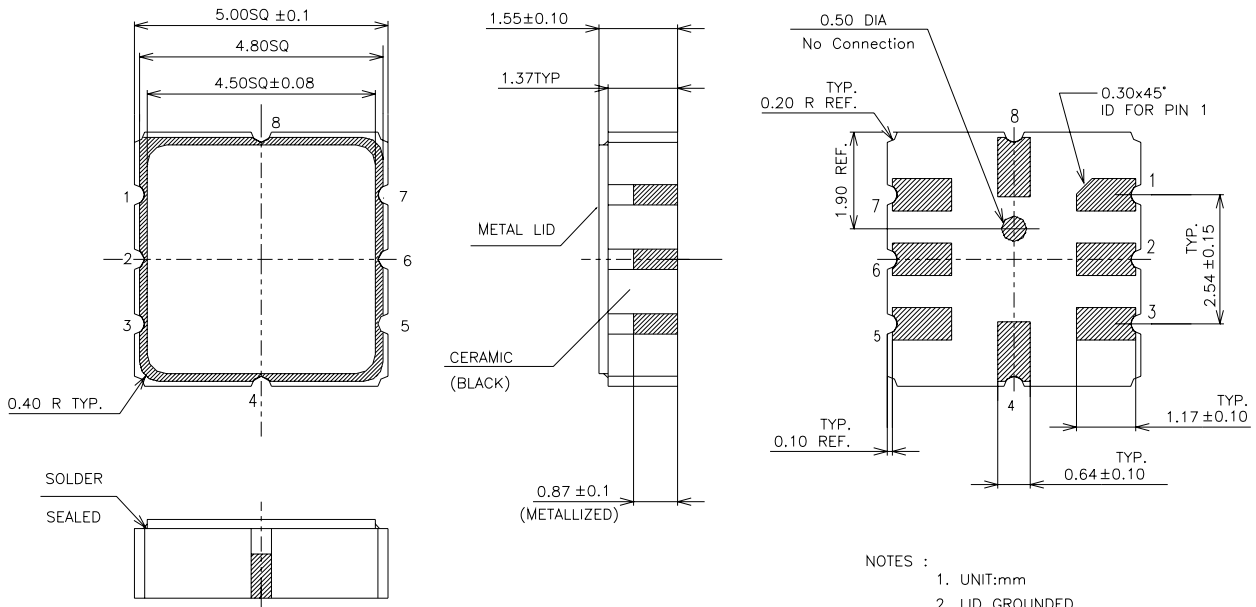

- NOTES :
1. UNIT:mm
 2. LID GROUNDED
 3. TOLERANCE UNLESS OTHERWISE SPECIFIED WITHIN ± 0.20

Hermetically Sealed Package Outline