



Chipsmall Limited consists of a professional team with an average of over 10 year of expertise in the distribution of electronic components. Based in Hongkong, we have already established firm and mutual-benefit business relationships with customers from,Europe,America and south Asia,supplying obsolete and hard-to-find components to meet their specific needs.

With the principle of "Quality Parts,Customers Priority,Honest Operation,and Considerate Service",our business mainly focus on the distribution of electronic components. Line cards we deal with include Microchip,ALPS,ROHM,Xilinx,Pulse,ON,Everlight and Freescale. Main products comprise IC,Modules,Potentiometer,IC Socket,Relay,Connector.Our parts cover such applications as commercial,industrial, and automotives areas.

We are looking forward to setting up business relationship with you and hope to provide you with the best service and solution. Let us make a better world for our industry!



Contact us

Tel: +86-755-8981 8866 Fax: +86-755-8427 6832

Email & Skype: info@chipsmall.com Web: www.chipsmall.com

Address: A1208, Overseas Decoration Building, #122 Zhenhua RD., Futian, Shenzhen, China





5V – 48V Powermite1, Surface Mount Transient Voltage Suppressors

DESCRIPTION

Microsemi's unique and new Powermite MUPT series of transient voltage suppressors feature oxide-passivated chips with high-temperature solder bonds for high surge capability and negligible electrical degradation under repeated surge conditions. Both unidirectional and bidirectional configurations are available. In addition to its size advantages, the Powermite package includes a fully metallic bottom (anode) side that eliminates the possibility of solder flux entrapment at assembly and a unique locking tab design serves as an integral heat sink. Its innovative design makes this device fully compatible for use with automatic insertion equipment.

Important: For the latest information, visit our website <http://www.microsemi.com>.

FEATURES

- Powermite package with standoff voltages 5 to 48 V.
- Both unidirectional and bidirectional polarities:
 - Anode to case bottom (MUPT5e3 thru MUPT48e3)
 - Bidirectional (MUPTB5e3 thru MUPTB48e3)
- Clamping time less than 100 pico-seconds for unidirectional and 5 nano-seconds for bidirectional.
- 100% surge current testing of all parts.
- Moisture classification is Level 1 with no dry pack required per IPC/JEDEC J-STD-020B.
- Both RoHS and non-RoHS compliant versions available.

APPLICATIONS / BENEFITS

- Protects sensitive components such as IC's, CMOS, Bipolar, BiCMOS, ECL, DTL, T²L, etc.
- Protection from switching and induced RF transients.
 - Integral heat sink / locking tabs
 - Fully metallic bottom side eliminates flux entrapment
- Compliant to IEC61000-4-2 and IEC61000-4-4 for ESD and EFT protection respectively.
- Secondary lightning protection per IEC61000-4-5 with 42 Ohms source impedance:
 - Class 1: MUPT5 /MUPTB8 to 17
 - Class 2: MUPT5 /MUPTB5 to 12

MAXIMUM RATINGS

Parameters/Test Conditions	Symbol	Value		Unit
Junction and Storage Temperature	T _J / T _{STG}	-65 to +150		°C
Thermal Resistance Junction-to-Ambient ⁽¹⁾	R _{θJA}	240		°C/W
Thermal Resistance Junction-to-Case (base tab)	R _{θJC}	15		°C/W
Peak Pulse Power (see Figure 1 and Figure 2)	P _{PP}	@ 8/20 μs	@ 10/1000μs	W
MUPT5e3 thru MUPT48e3:		1000	150	
MUPTB5e3 thru MUPTB48e3:		1000	150	
Rated Average Power Dissipation (base tab ≤ 112 °C)	P _{M(AV)}	2.5		W
Impulse Repetition Rate (duty factor)		0.01		%
Solder Temperature @ 10 s	T _{SP}	260		°C

Notes: 1. When mounted on FR4 PC board with 1 oz copper.

High-Reliability
Screening available in
reference to
MIL-PRF-19500

Tested in accordance
with the requirements of
AEC-Q101

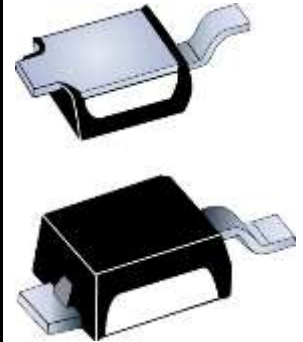

**DO-216AA
Package**

Power Discretes & Modules
Business Unit
Discrete Products Group
Microsemi Corporation

PDM – Lawrence

6 Lake Street,
Lawrence, MA 01841
Tel: 1-800-446-1158 or
(978) 620-2600
Fax: (978) 689-0803

PDM – Ireland

Gort Road Business Park,
Ennis, Co. Clare, Ireland
Tel: +353 (0) 65 6840044
Fax: +353 (0) 65 6822298

Website:

www.microsemi.com

MECHANICAL and PACKAGING

- CASE: Void-free transfer molded thermosetting epoxy compound meeting UL94V-0.
- TERMINALS: Annealed matte-tin plating over copper and readily solderable per MIL-STD-750, method 2026.
- MARKING:
 - Anode to TAB 1:** “T” plus the last two digits of part number underlined, e.g. MUPT5e3 is T05, MUPT12e3 is T12.
 - Bipolar:** “B” plus the last two digits of part number underlined, e.g. MUPTB8e3 is B08, MUPTB12e3 is B12, etc.
 - Please note dot suffix (for e3 suffix)*
- POLARITY: Anode to TAB 1 (bottom) as described in marking above and on [last page](#).
- TAPE & REEL option: Standard per EIA-481-B using 12 mm tape. Consult factory for quantities.
- WEIGHT: Approximately 0.016 gram.
- See [package dimensions](#) on last page.

PART NOMENCLATURE

Applicable to unidirectional MUPT5e3 – MUPT48e3 only:

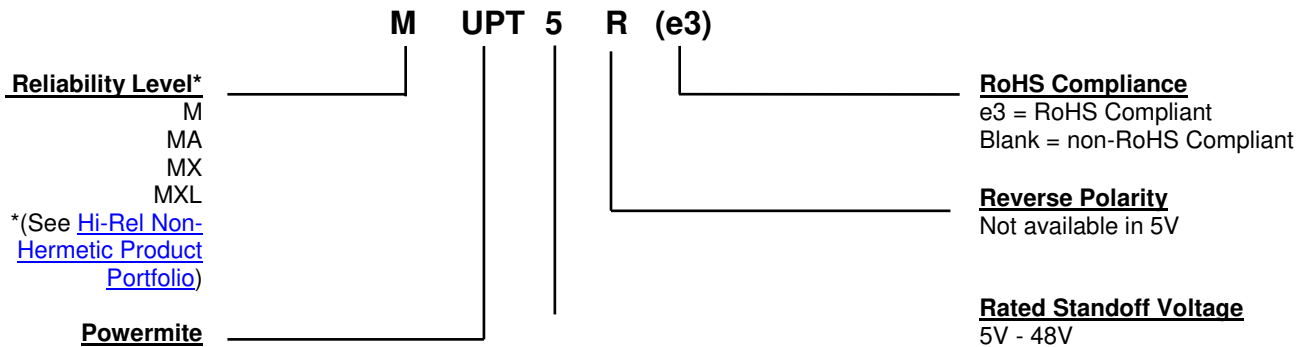

Applicable to bidirectional MUPTB5e3 – MUPTB48e3 only:

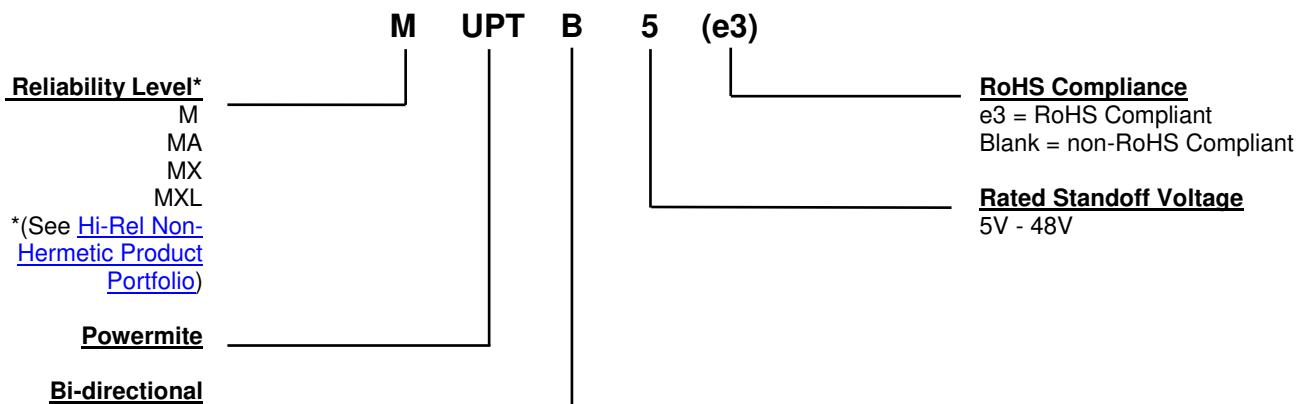

SYMBOLS & DEFINITIONS

Symbol	Definition
$V_{(BR)}$	Breakdown Voltage: The minimum voltage the device will exhibit at a specified current.
V_{WM}	Working Peak Standoff Voltage: The maximum peak voltage that can be applied over the operating temperature range.
P_{PP}	Peak Pulse Power: The peak power that can be applied for a specified pulse width and waveform.
I_D	Standby Current: The maximum current that will flow at the specified voltage and temperature.
I_{PP}	Peak Pulse Current: The peak current that can be applied for a specified pulse width and waveform.
C	Capacitance: The capacitance in picofarads of the TVS as defined @ 0 volts at a frequency of 1 MHz.

ELECTRICAL CHARACTERISTICS

DEVICE TYPE		RATED STANDOFF VOLTAGE	MINIMUM BREAKDOWN VOLTAGE	MAXIMUM STANDBY CURRENT	MAXIMUM PEAK PULSE CURRENT*	MAXIMUM CLAMPING VOLTAGE	MAXIMUM TEMPERATURE COEFFICIENT of $V_{(BR)}$
Uni-directional	Bi-directional	V_{WM}	$V_{(BR)} @ 1 \text{ mA}$	$I_D @ V_{WM}$	$I_{PP} @ 10/1000 \mu\text{s}$	$V_C @ I_{PP}$	$\alpha_{V(BR)}$
		V	V	μA	A	V	%/°C
MUPT5	MUPTB5	5	6.0	50	15.7	9.5	0.030
MUPT8	MUPTB8	8	9.0	2	10.9	13.7	0.040
MUPT10	MUPTB10	10	11.0	2	8.33	18.0	0.045
MUPT12	MUPTB12	12	13.8	1	6.94	21.6	0.050
MUPT15	MUPTB15	15	16.7	1	5.77	26.0	0.055
MUPT17	MUPTB17	17	19.0	1	5.14	29.2	0.060
MUPT24	MUPTB24	24	28.4	1	3.47	43.2	0.070
MUPT28	MUPTB28	28	31.0	1	3.13	47.8	0.075
MUPT33	MUPTB33	33	36.8	1	2.65	56.7	0.080
MUPT48	MUPTB48	48	54.0	1	1.78	84.3	0.090

* See [Figure 2](#) for I_{PP} waveform of 10/1000 μs test pulse.

GRAPHS

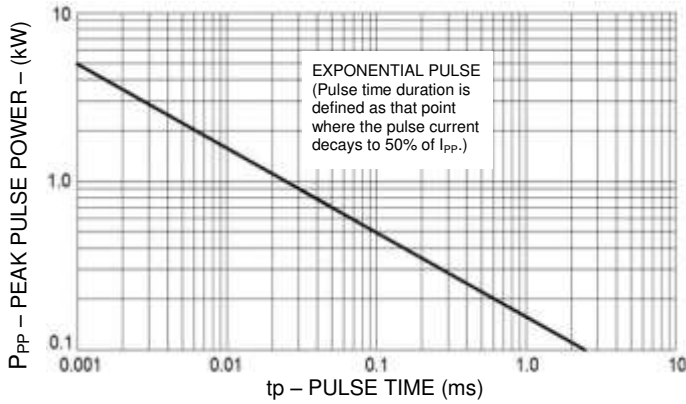

FIGURE 1
Peak Pulse Power vs. Pulse Duration

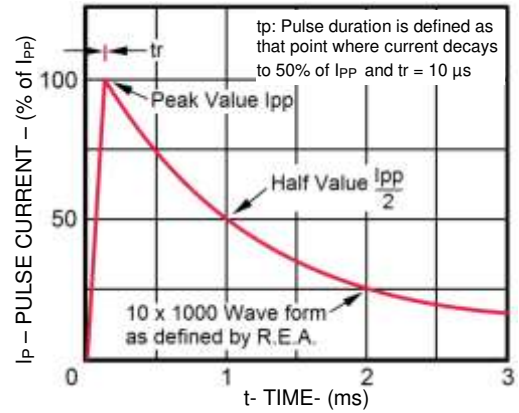

FIGURE 2
Pulse Waveform for 10/1000 μ s Exponential Surge

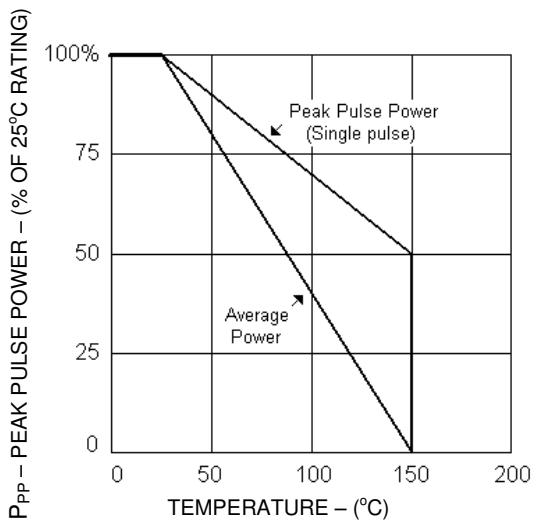

FIGURE 3
Derating Curve

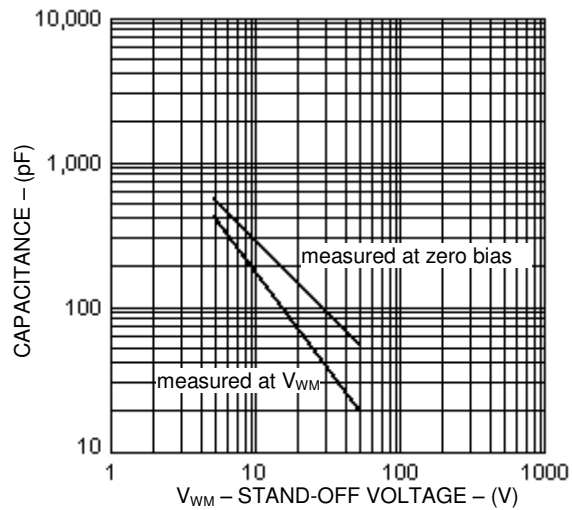
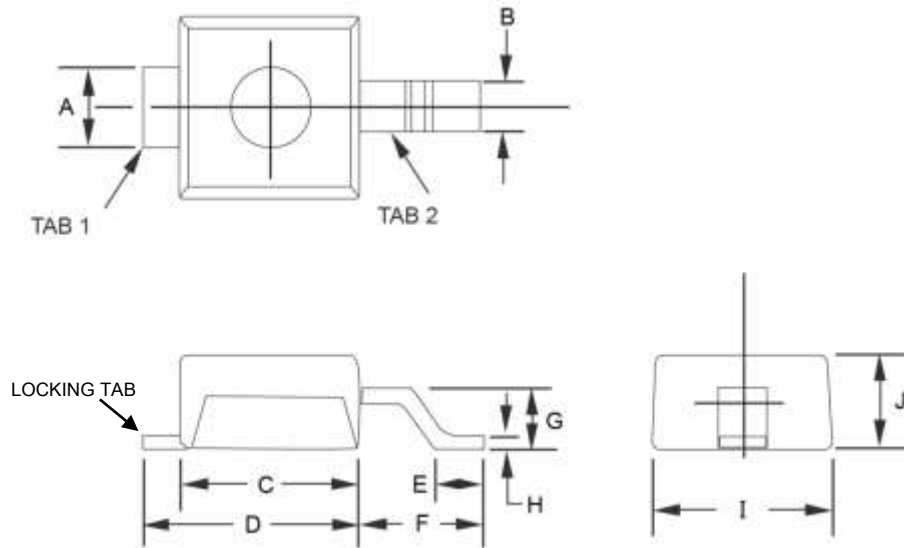
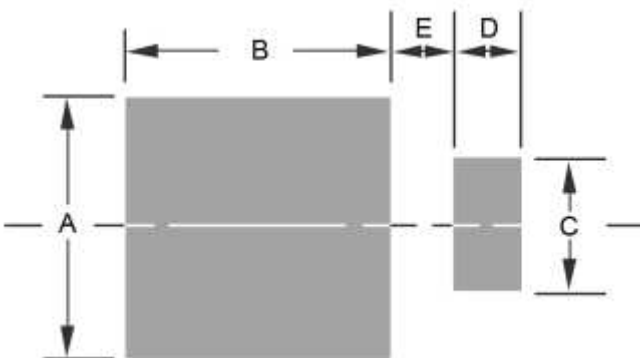

FIGURE 4
Typical Capacitance vs. Stand-Off Voltage

PACKAGE DIMENSIONS

Ltr	Dimensions			
	Inch		Millimeters	
	Min	Max	Min	Max
A	0.029	0.039	0.73	0.99
B	0.016	0.026	0.40	0.66
C	0.070	0.080	1.77	2.03
D	0.087	0.097	2.21	2.46
E	0.020	0.030	0.50	0.76
F	0.051	0.061	1.29	1.54
G	0.021	0.031	0.53	0.78
H	0.004	0.008	0.10	0.20
I	0.070	0.080	1.77	2.03
J	0.035	0.045	0.89	1.14

PAD LAYOUT

Ltr	Dimensions	
	Inch	Millimeters
A	0.100	2.54
B	0.105	2.67
C	0.050	1.27
D	0.030	0.76
E	0.025	0.64