



Chipsmall Limited consists of a professional team with an average of over 10 year of expertise in the distribution of electronic components. Based in Hongkong, we have already established firm and mutual-benefit business relationships with customers from,Europe,America and south Asia,supplying obsolete and hard-to-find components to meet their specific needs.

With the principle of “Quality Parts,Customers Priority,Honest Operation,and Considerate Service”,our business mainly focus on the distribution of electronic components. Line cards we deal with include Microchip,ALPS,ROHM,Xilinx,Pulse,ON,Everlight and Freescale. Main products comprise IC,Modules,Potentiometer,IC Socket,Relay,Connector.Our parts cover such applications as commercial,industrial, and automotives areas.

We are looking forward to setting up business relationship with you and hope to provide you with the best service and solution. Let us make a better world for our industry!



## Contact us

Tel: +86-755-8981 8866 Fax: +86-755-8427 6832

Email & Skype: info@chipsmall.com Web: www.chipsmall.com

Address: A1208, Overseas Decoration Building, #122 Zhenhua RD., Futian, Shenzhen, China



# N57M5127

## 32-tap Digital Potentiometer (POT) with Wiper Storage

### Description

The N57M5127 is a single digital POTs designed as an electronic replacement for mechanical potentiometers and trim pots. Ideal for automated adjustments on high volume production lines, it is also well suited for applications where equipment requiring periodic adjustment is either difficult to access or located in a hazardous or remote environment.

The N57M5127 contains a 32-tap series resistor array connected between two terminals  $R_H$  and  $R_L$ . An up/down counter and decoder that are controlled by three input pins, determines which tap is connected to the wiper. The wiper setting, stored in nonvolatile memory, is not lost when the device is powered down and is automatically reinstated when power is returned. The wiper can be adjusted to test new system values without effecting the stored setting. Wiper-control of the N57M5127 is accomplished with three input control pins,  $\overline{CS}$ ,  $U/\overline{D}$ , and  $\overline{INC}$ . The  $\overline{INC}$  input increments the wiper in the direction which is determined by the logic state of the  $U/\overline{D}$  input. The  $\overline{CS}$  input is used to select the device and also store the wiper position prior to power down.

The device is used as a two-terminal variable resistors. Digital POTs bring variability and programmability to a wide variety of applications including control, parameter adjustments, and signal processing.

### Features

- 32-position Linear Taper Potentiometer
- Non-volatile EEPROM Wiper Storage
- Low Standby Current
- Single Supply Operation: 2.7 V – 5.5 V
- Increment Up/Down Serial Interface
- Resistance Values: 10 k $\Omega$ , 50 k $\Omega$  and 100 k $\Omega$
- 8-Lead MSOP Package
- This Device is Pb-Free, Halogen Free/BFR Free and are RoHS Compliant

### Applications

- Automated Product Calibration
- Remote Control Adjustments
- Offset, Gain and Zero Control
- Tamper-proof Calibrations
- Contrast, Brightness and Volume Controls
- Motor Controls and Feedback Systems
- Programmable Analog Functions



ON Semiconductor®

[www.onsemi.com](http://www.onsemi.com)



MSOP-8  
Z SUFFIX  
CASE 846AD

### PIN CONFIGURATION

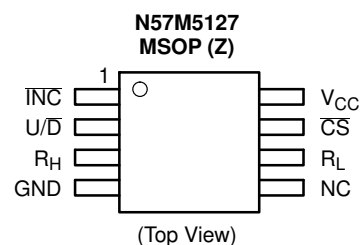

### ORDERING INFORMATION

See detailed ordering and shipping information in the package dimensions section on page 9 of this data sheet.

# N57M5127

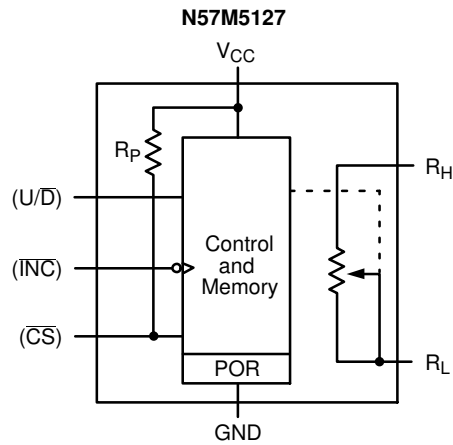

Figure 1. Functional Diagram

Table 1. PIN DESCRIPTIONS

Name	Function	MSOP
INC	Increment Control	1
U/D	Up/Down Control	2
R <sub>H</sub>	Potentiometer High Terminal	3
GND	Ground	4
NC	No Connect	5
R <sub>L</sub>	Potentiometer Low Terminal	6
$\overline{CS}$	Chip Select	7
V <sub>CC</sub>	Supply Voltage	8

## DEVICE DESCRIPTION

### $\overline{INC}$ : Increment Control Input

The  $\overline{INC}$  input moves the wiper in the up or down direction determined by the condition of the U/D input.

### U/D: Up/Down Control Input

The U/D input controls the direction of the wiper movement. When in a high state and  $\overline{CS}$  is low, any high-to-low transition on  $\overline{INC}$  will cause the wiper to move one increment toward the R<sub>H</sub> terminal. When in a low state and  $\overline{CS}$  is low, any high-to-low transition on  $\overline{INC}$  will cause the wiper to move one increment towards the R<sub>L</sub> terminal.

### R<sub>H</sub>: High End Potentiometer Terminal

R<sub>H</sub> is the high end terminal of the potentiometer. It is not required that this terminal be connected to a potential greater than the R<sub>L</sub> terminal. Voltage applied to the R<sub>H</sub> terminal cannot exceed the supply voltage, V<sub>CC</sub> or go below ground, GND.

### R<sub>L</sub>: Low End Potentiometer Terminal

R<sub>L</sub> is the low end terminal of the potentiometer. It is not required that this terminal be connected to a potential less than the R<sub>H</sub> terminal. Voltage applied to the R<sub>L</sub> terminal cannot exceed the supply voltage, V<sub>CC</sub> or go below ground, GND. R<sub>L</sub> and R<sub>H</sub> are electrically interchangeable.

### $\overline{CS}$ : Chip Select

The chip select input is used to activate the control input of the device and is active low. When in a high state, activity on the  $\overline{INC}$  and U/D inputs will not affect or change the position of the wiper. There is an internal pull-up resistor on the  $\overline{CS}$  input pin.

### V<sub>CC</sub>: Supply Input for the device.



DEVICE OPERATION

The N57M5127 operates like a digitally controlled variable resistor with  $R_H$  and  $R_L$  equivalent to the high and low terminals. There are 32 available tap positions including the resistor end points,  $R_H$  and  $R_L$ . There are 31 resistor elements connected in series between the  $R_H$  and  $R_L$  terminals.

Operation is controlled by three inputs,  $\overline{INC}$ ,  $U/\overline{D}$  and  $\overline{CS}$ . These inputs control a five-bit up/down counter whose output is decoded to select the wiper position. The selected wiper position can be stored in nonvolatile memory using the  $\overline{INC}$  and  $\overline{CS}$  inputs.

With  $\overline{CS}$  set LOW, the device is selected and will respond to the  $U/\overline{D}$  and  $\overline{INC}$  inputs. HIGH to LOW transitions on  $\overline{INC}$  will increment or decrement the wiper (depending on

the state of the  $U/\overline{D}$  input and five-bit counter). The wiper, when at either end terminal, acts like its mechanical equivalent and does not move beyond the last position. The value of the counter is stored in nonvolatile memory whenever  $\overline{CS}$  transitions HIGH while the  $\overline{INC}$  input is also HIGH. When the device is powered-down, the last stored wiper counter position is maintained in the nonvolatile memory. When power is restored, the contents of the memory are recalled and the counter is set to the value stored.

With  $\overline{INC}$  set low, the device may be de-selected and powered down without storing the current wiper position in nonvolatile memory. This allows the system to always power up to a preset value stored in nonvolatile memory.

Table 2. OPERATION MODES

INC	CS	U/D	Operation
High to Low	Low	High	Wiper toward H
High to Low	Low	Low	Wiper toward L/GND
High	Low to High	X	Store Wiper Position
Low	Low to High	X	No Store, Return to Standby
X	High	X	Standby

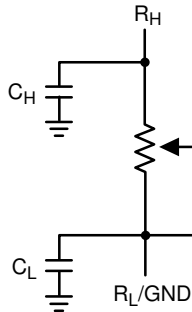

Figure 2. Variable Resistor Equivalent Circuit

# N57M5127

**Table 3. ABSOLUTE MAXIMUM RATINGS**

Parameters	Ratings	Units
Supply Voltage $V_{CC}$ to GND	-0.5 to +7	V
Inputs CS to GND INC to GND U/D to GND H to GND L to GND W to GND	-0.5 to $V_{CC} + 0.5$ -0.5 to $V_{CC} + 0.5$ -0.5 to $V_{CC} + 0.5$ -0.5 to $V_{CC} + 0.5$ -0.5 to $V_{CC} + 0.5$ -0.5 to $V_{CC} + 0.5$	V
Operating Ambient Temperature Commercial ('C' or Blank suffix) Industrial ('I' suffix)	0 to 70 -40 to +85	°C
Junction Temperature	+150	°C
Storage Temperature	-65 to 150	°C
Lead Soldering (10 s max)	+300	°C

Stresses exceeding those listed in the Maximum Ratings table may damage the device. If any of these limits are exceeded, device functionality should not be assumed, damage may occur and reliability may be affected.

**Table 4. RELIABILITY CHARACTERISTICS**

Symbol	Parameter	Test Method	Min	Typ	Max	Units
$V_{ZAP}$ (Note 1)	ESD Susceptibility	MIL-STD-883, Test Method 3015	2000			V
$I_{LTH}$ (Notes 1, 2)	Latch-up	JEDEC Standard 17	100			mA
$T_{DR}$	Data Retention	MIL-STD-883, Test Method 1008	100			Years
$N_{END}$	Endurance	MIL-STD-883, Test Method 1003	1,000,000			Stores

1. This parameter is tested initially and after a design or process change that affects the parameter.
2. Latch-up protection is provided for stresses up to 100 mA on address and data pins from -1 V to  $V_{CC} + 1$  V
3. These parameters are periodically sampled and are not 100% tested.

# N57M5127

**Table 5. DC ELECTRICAL CHARACTERISTICS** ( $V_{CC} = +2.7\text{ V}$  to  $+5.5\text{ V}$  unless otherwise specified)

Symbol	Parameter	Conditions	Min	Typ	Max	Units
<b>POWER SUPPLY</b>						
$V_{CC}$	Operating Voltage Range		2.7		5.5	V
$I_{CC1}$	Supply Current (Increment)	$V_{CC} = 5.5\text{ V}$ , $f = 1\text{ MHz}$ , $I_W = 0$			260	$\mu\text{A}$
		$V_{CC} = 3.3\text{ V}$ , $f = 1\text{ MHz}$ , $I_W = 0$			150	$\mu\text{A}$
$I_{CC2}$	Supply Current (Write)	Programming, $V_{CC} = 5.5\text{ V}$		300	600	$\mu\text{A}$
		Programming, $V_{CC} = 3.3\text{ V}$		150	400	$\mu\text{A}$
$I_{SB1}$ (Note 4)	Supply Current (Standby)	$\overline{CS} = V_{CC} - 0.3\text{ V}$ $U/\overline{D}$ , $\overline{INC} = V_{CC}$ or GND		0.35	1	$\mu\text{A}$
<b>LOGIC INPUTS</b>						
$I_{IH}$	Input Leakage Current	$U/\overline{D}$ , $\overline{INC} = V_{CC}$			1	$\mu\text{A}$
		$\overline{CS} = V_{CC} - 0.3\text{ V}$			1	$\mu\text{A}$
$I_{IL}$	Input Leakage Current	$U/\overline{D}$ , $\overline{INC} = 0$			-1	$\mu\text{A}$
		$\overline{CS} = 0$			-120	$\mu\text{A}$
$V_{IH}$	High Level Input Voltage		$V_{CC} \times 0.7$		$V_{CC} + 0.3$	V
$V_{IL}$	Low Level Input Voltage		-0.3		$V_{CC} \times 0.2$	V

**Table 6. POTENTIOMETER CHARACTERISTICS**

Symbol	Parameter	Conditions	Min	Typ	Max	Units
$R_{POT}$	Potentiometer Resistance	-10 Device		10		$k\Omega$
		-50 Device		50		
		-00 Device		100		
$R_{TOL}$	Pot Resistance Tolerance				$\pm 20$	%
$V_{RH}$	Voltage on $R_H$ pin		0		$V_{CC}$	V
$V_{RL}$	Voltage on $R_L$ pin		0		$V_{CC}$	V
RES	Resolution			3.2		%
INL	Integral Linearity Error				0.5	LSB
DNL	Differential Linearity Error				0.25	LSB
$R_{Wi}$	Wiper Resistance	$V_{CC} = 5\text{ V}$		70	100	$\Omega$
		$V_{CC} = 2.7\text{ V}$		150	200	$\Omega$
$TC_{RPOT}$ (Note 6)	TC of Pot Resistance			$\pm 30$	$\pm 300$	ppm/ $^{\circ}\text{C}$
$TC_{RATIO}$ (Note 6)	Ratiometric TC			$\pm 3$	20	ppm/ $^{\circ}\text{C}$
$V_N$ (Note 6)	Noise	100 kHz / 1 kHz		8/24		nV/ $\sqrt{\text{Hz}}$
$C_H/C_L/C_W$ (Note 6)	Potentiometer Capacitances			8/8/25		pF
$F_c$ (Note 6)	Frequency Response	Passive Attenuator, 10 $k\Omega$		1.7		MHz

4. Latch-up protection is provided for stresses up to 100 mA on address and data pins from  $-1\text{ V}$  to  $V_{CC} + 1\text{ V}$

5.  $I_W$  = source or sink

6. These parameters are periodically sampled and are not 100% tested.

Product parametric performance is indicated in the Electrical Characteristics for the listed test conditions, unless otherwise noted. Product performance may not be indicated by the Electrical Characteristics if operated under different conditions.

**Table 7. AC TEST CONDITIONS**

V <sub>CC</sub> Range	2.7 V ≤ V <sub>CC</sub> ≤ 5.5 V
Input Pulse Levels	0.2 × V <sub>CC</sub> to 0.7 × V <sub>CC</sub>
Input Rise and Fall Times	10 ns
Input Reference Levels	0.5 × V <sub>CC</sub>

**Table 8. AC OPERATING CHARACTERISTICS** (V<sub>CC</sub> = +2.7 V to +5.5 V, V<sub>H</sub> = V<sub>CC</sub>, V<sub>L</sub> = 0 V, unless otherwise specified)

Symbol	Parameter	Min	Typ (Note 7)	Max	Units
t <sub>CI</sub>	$\overline{CS}$ to $\overline{INC}$ Setup	100			ns
t <sub>DI</sub>	U/ $\overline{D}$ to $\overline{INC}$ Setup	50			ns
t <sub>ID</sub>	U/ $\overline{D}$ to $\overline{INC}$ Hold	100			ns
t <sub>IL</sub>	$\overline{INC}$ LOW Period	250			ns
t <sub>IH</sub>	$\overline{INC}$ HIGH Period	250			ns
t <sub>IC</sub>	$\overline{INC}$ Inactive to $\overline{CS}$ Inactive	1			μs
t <sub>CPH</sub>	$\overline{CS}$ Deselect Time (NO STORE)	100			ns
t <sub>CPH</sub>	$\overline{CS}$ Deselect Time (STORE)	10			ms
t <sub>IR</sub>	$\overline{INC}$ to R <sub>H</sub> Change		1	5	μs
t <sub>CYC</sub>	$\overline{INC}$ Cycle Time	1			μs
t <sub>R</sub> , t <sub>F</sub> (Note 8)	$\overline{INC}$ Input Rise and Fall Time			500	μs
t <sub>PU</sub> (Note 8)	Power-up to Wiper Stable			1	ms
t <sub>WR</sub>	Store Cycle		2	5	ms

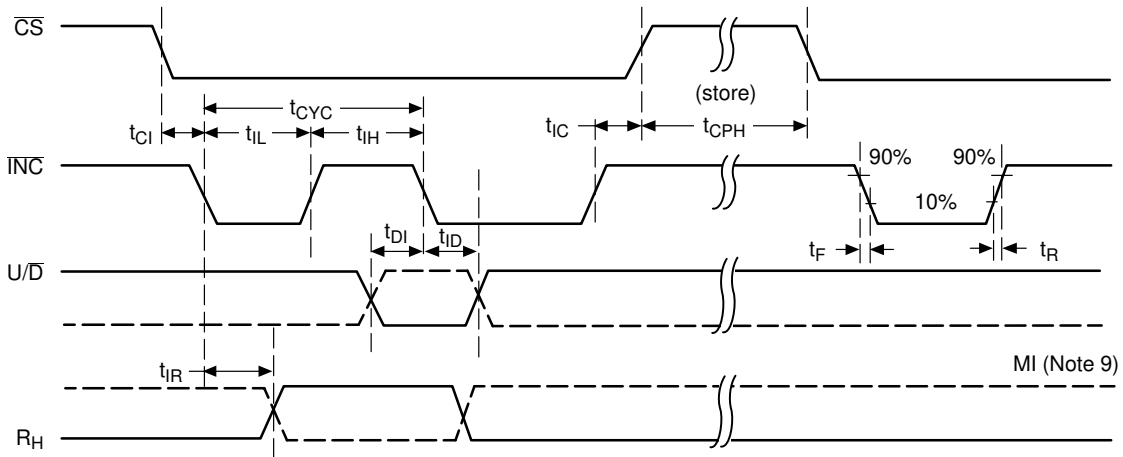

**Figure 3. A.C. Timing**

- 7. Typical values are for T<sub>A</sub> = 25°C and nominal supply voltage.
- 8. This parameter is periodically sampled and not 100% tested.
- 9. MI in the A.C. Timing diagram refers to the minimum incremental change in the W output due to a change in the wiper position.

APPLICATION INFORMATION

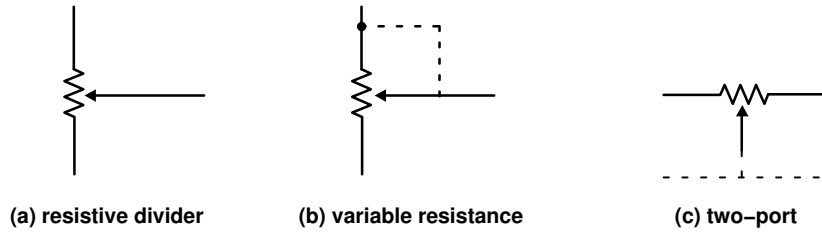

Figure 4. Potentiometer Configurations

Applications

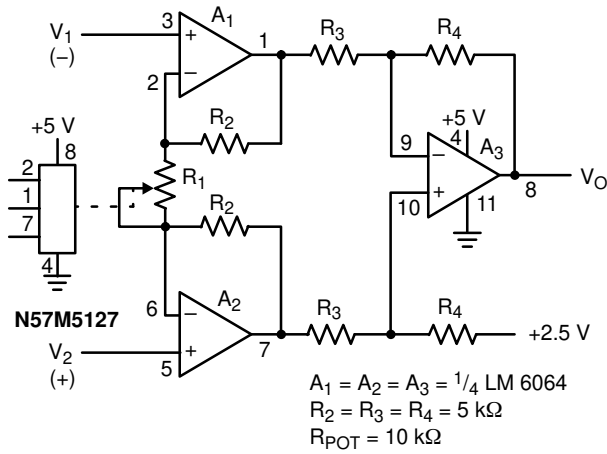

Figure 5. Programmable Instrumentation Amplifier

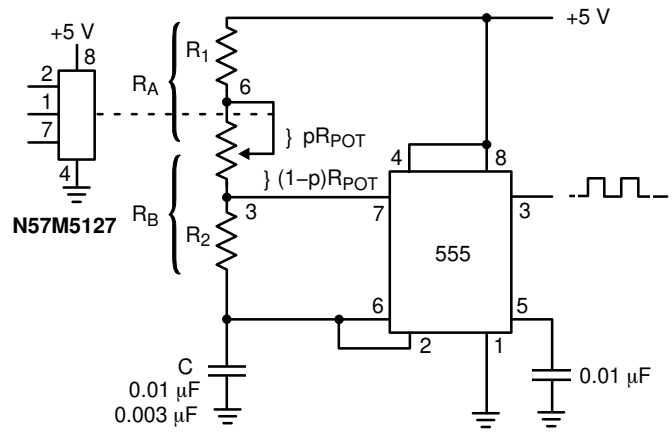

Figure 6. Programmable Sq. Wave Oscillator (555)

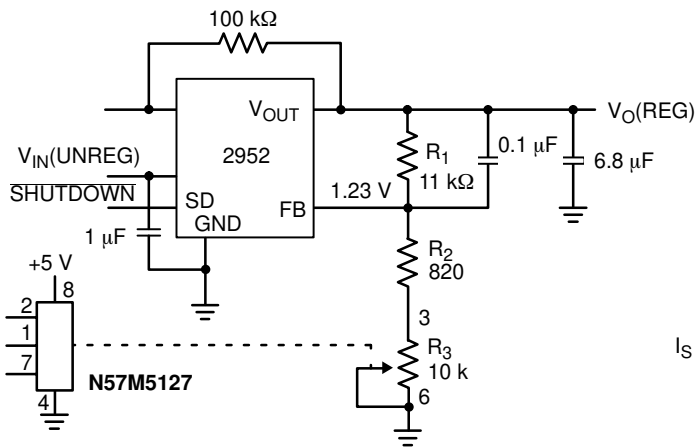

Figure 7. Programmable Voltage Regulator

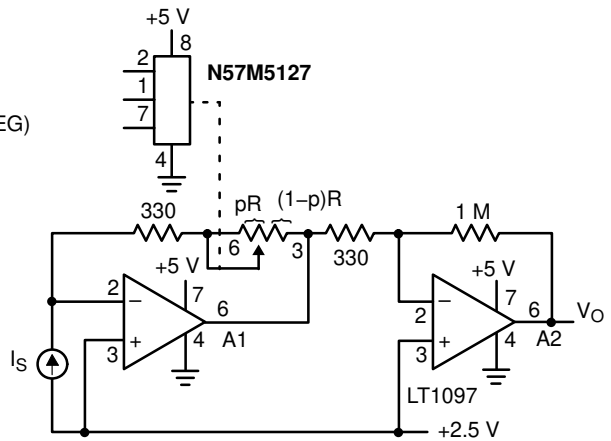

Figure 8. Programmable I to V Converter



# N57M5127

## PACKAGE DIMENSIONS

MSOP 8, 3x3  
CASE 846AD  
ISSUE O

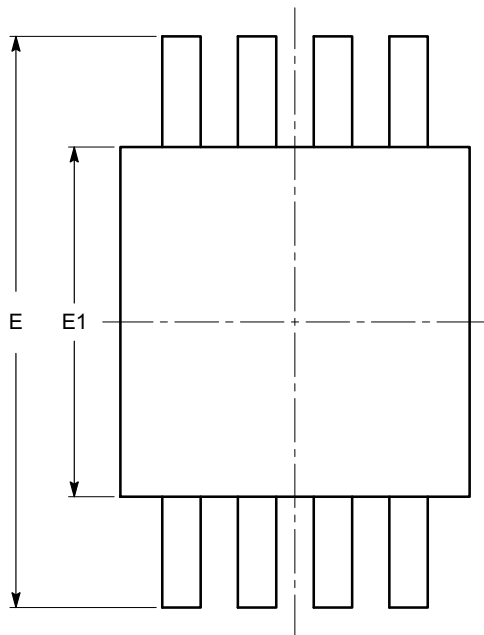

TOP VIEW

SYMBOL	MIN	NOM	MAX
A			1.10
A1	0.05	0.10	0.15
A2	0.75	0.85	0.95
b	0.22		0.38
c	0.13		0.23
D	2.90	3.00	3.10
E	4.80	4.90	5.00
E1	2.90	3.00	3.10
e	0.65 BSC		
L	0.40	0.60	0.80
L1	0.95 REF		
L2	0.25 BSC		
$\theta$	0°		6°

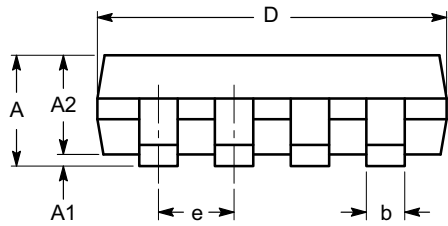

SIDE VIEW

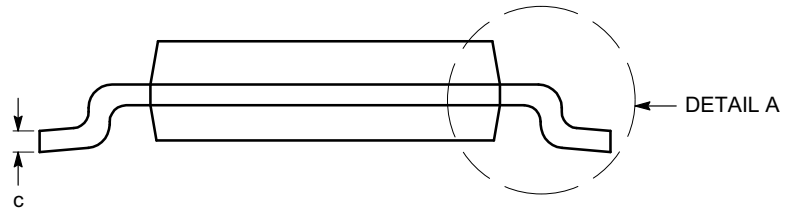

END VIEW

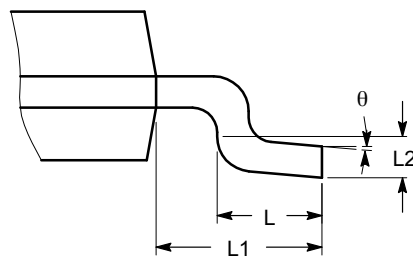

DETAIL A

**Notes:**

- (1) All dimensions are in millimeters. Angles in degrees.
- (2) Complies with JEDEC MO-187.

# N57M5127

**Table 9. ORDERING INFORMATION** (Notes 10, 11)

Device	Orderable Part Number	Resistor [kΩ]	Top Marking	Package/Pins	Shipping†
N57M5127	N57M5127ZD10TG	10	ABNA	MSOP-8	3000 / Tape & Reel
	N57M5127ZD50TG (Note 13)	50	ABNB	MSOP-8	3000 / Tape & Reel

†For information on tape and reel specifications, including part orientation and tape sizes, please refer to our Tape and Reel Packaging Specifications Brochure, BRD8011/D.

10. All packages are RoHS-compliant (Lead-free, Halogen-free).

11. The standard lead finish is NiPdAu.

12. For additional package and temperature options, please contact your nearest ON Semiconductor Sales office.

13. Contact factory for availability.

14. For detailed information and a breakdown of device nomenclature and numbering systems, please see the ON Semiconductor Device Nomenclature document, TND310/D, available at [www.onsemi.com](http://www.onsemi.com).

ON Semiconductor and  are trademarks of Semiconductor Components Industries, LLC dba ON Semiconductor or its subsidiaries in the United States and/or other countries. ON Semiconductor owns the rights to a number of patents, trademarks, copyrights, trade secrets, and other intellectual property. A listing of ON Semiconductor's product/patent coverage may be accessed at [www.onsemi.com/site/pdf/Patent-Marketing.pdf](http://www.onsemi.com/site/pdf/Patent-Marketing.pdf). ON Semiconductor reserves the right to make changes without further notice to any products herein. ON Semiconductor makes no warranty, representation or guarantee regarding the suitability of its products for any particular purpose, nor does ON Semiconductor assume any liability arising out of the application or use of any product or circuit, and specifically disclaims any and all liability, including without limitation special, consequential or incidental damages. Buyer is responsible for its products and applications using ON Semiconductor products, including compliance with all laws, regulations and safety requirements or standards, regardless of any support or applications information provided by ON Semiconductor. "Typical" parameters which may be provided in ON Semiconductor data sheets and/or specifications can and do vary in different applications and actual performance may vary over time. All operating parameters, including "Typicals" must be validated for each customer application by customer's technical experts. ON Semiconductor does not convey any license under its patent rights nor the rights of others. ON Semiconductor products are not designed, intended, or authorized for use as a critical component in life support systems or any FDA Class 3 medical devices or medical devices with a same or similar classification in a foreign jurisdiction or any devices intended for implantation in the human body. Should Buyer purchase or use ON Semiconductor products for any such unintended or unauthorized application, Buyer shall indemnify and hold ON Semiconductor and its officers, employees, subsidiaries, affiliates, and distributors harmless against all claims, costs, damages, and expenses, and reasonable attorney fees arising out of, directly or indirectly, any claim of personal injury or death associated with such unintended or unauthorized use, even if such claim alleges that ON Semiconductor was negligent regarding the design or manufacture of the part. ON Semiconductor is an Equal Opportunity/Affirmative Action Employer. This literature is subject to all applicable copyright laws and is not for resale in any manner.

## PUBLICATION ORDERING INFORMATION

### LITERATURE FULFILLMENT:

Literature Distribution Center for ON Semiconductor  
19521 E. 32nd Pkwy, Aurora, Colorado 80011 USA  
**Phone:** 303-675-2175 or 800-344-3860 Toll Free USA/Canada  
**Fax:** 303-675-2176 or 800-344-3867 Toll Free USA/Canada  
**Email:** [orderlit@onsemi.com](mailto:orderlit@onsemi.com)

**N. American Technical Support:** 800-282-9855 Toll Free  
USA/Canada  
**Europe, Middle East and Africa Technical Support:**  
Phone: 421 33 790 2910

**ON Semiconductor Website:** [www.onsemi.com](http://www.onsemi.com)

**Order Literature:** <http://www.onsemi.com/orderlit>

For additional information, please contact your local Sales Representative