



Chipsmall Limited consists of a professional team with an average of over 10 year of expertise in the distribution of electronic components. Based in Hongkong, we have already established firm and mutual-benefit business relationships with customers from,Europe,America and south Asia,supplying obsolete and hard-to-find components to meet their specific needs.

With the principle of “Quality Parts,Customers Priority,Honest Operation,and Considerate Service”,our business mainly focus on the distribution of electronic components. Line cards we deal with include Microchip,ALPS,ROHM,Xilinx,Pulse,ON,Everlight and Freescale. Main products comprise IC,Modules,Potentiometer,IC Socket,Relay,Connector.Our parts cover such applications as commercial,industrial, and automotives areas.

We are looking forward to setting up business relationship with you and hope to provide you with the best service and solution. Let us make a better world for our industry!



Contact us

Tel: +86-755-8981 8866 Fax: +86-755-8427 6832

Email & Skype: info@chipsmall.com Web: www.chipsmall.com

Address: A1208, Overseas Decoration Building, #122 Zhenhua RD., Futian, Shenzhen, China



DATA SHEET

74F175A

Quad D flip-flop

Product specification
Supersedes data of 1996 Mar 12
IC15 Data Handbook

2000 Jun 30

Quad D flip-flop

74F175A

FEATURES

- Four edge-triggered D-type flip-flops
- Buffered common clock
- Buffered asynchronous Master Reset
- True and complementary outputs
- Industrial temperature range available (-40°C to +85°C)
- PNP light loading inputs

DESCRIPTION

The 74F175A is a quad, edge-triggered D-type flip-flop with individual D inputs and both Q and \bar{Q} outputs. The common buffered Clock (CP) and Master Reset (\overline{MR}) inputs load and reset (clear) all flip-flops simultaneously.

The register is fully edge-triggered. The state of each D input, one setup time before the Low-to-High clock transition is transferred to the corresponding flip-flop's Q output.

All Q outputs will be forced Low independently of clock or data inputs by a Low voltage level on the \overline{MR} input. The device is useful for applications where both true and complementary outputs are required, and the CP and \overline{MR} are common to all storage elements.

PIN CONFIGURATION

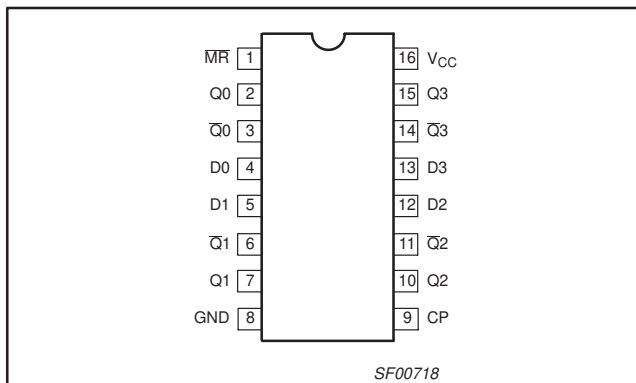

TYPE	TYPICAL f_{max}	TYPICAL SUPPLY CURRENT (TOTAL)
74F175A	160MHz	22mA

ORDERING INFORMATION

DESCRIPTION	ORDER CODE		PKG. DWG. #
	COMMERCIAL RANGE $V_{CC} = 5V \pm 10\%$, $T_{amb} = 0^{\circ}C$ to $+70^{\circ}C$	INDUSTRIAL RANGE $V_{CC} = 5V \pm 10\%$, $T_{amb} = -40^{\circ}C$ to $+85^{\circ}C$	
16-pin plastic DIP	N74F175AN	I74F175AN	SOT38-4
16-pin plastic SO	N74F175AD	I74F175AD	SOT109-1

INPUT AND OUTPUT LOADING AND FAN OUT TABLE

PINS	DESCRIPTION	74F (U.L.) HIGH/LOW	LOAD VALUE HIGH/LOW
D0 – D3	Data inputs	74F175A	1.0/0.033
\overline{MR}	Master reset input (active-Low)	74F175A	1.0/0.033
CP	Clock input (active rising edge)	74F175A	1.0/0.033
Q0–Q3	True outputs		50/33
$\bar{Q}0-\bar{Q}3$	Complementary outputs		50/33

NOTE:

One (1.0) FAST unit load is defined as: 20µA in the High state and 0.6mA in the Low state.

Quad D flip-flop

74F175A

LOGIC SYMBOL

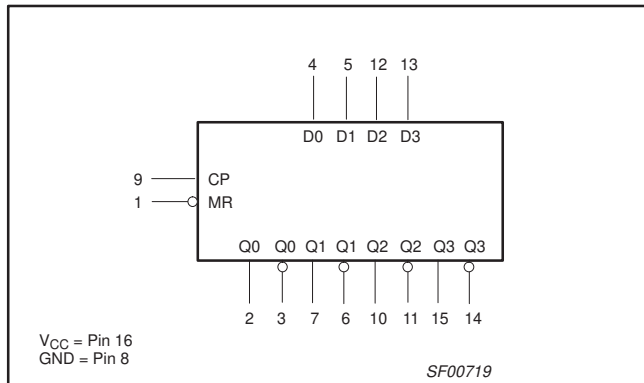

IEC/IEEE SYMBOL

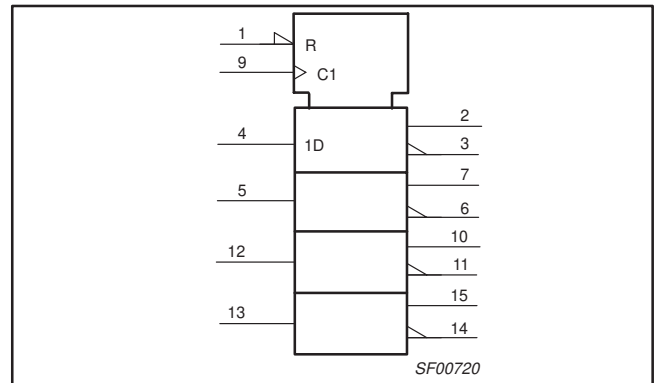

LOGIC DIAGRAM

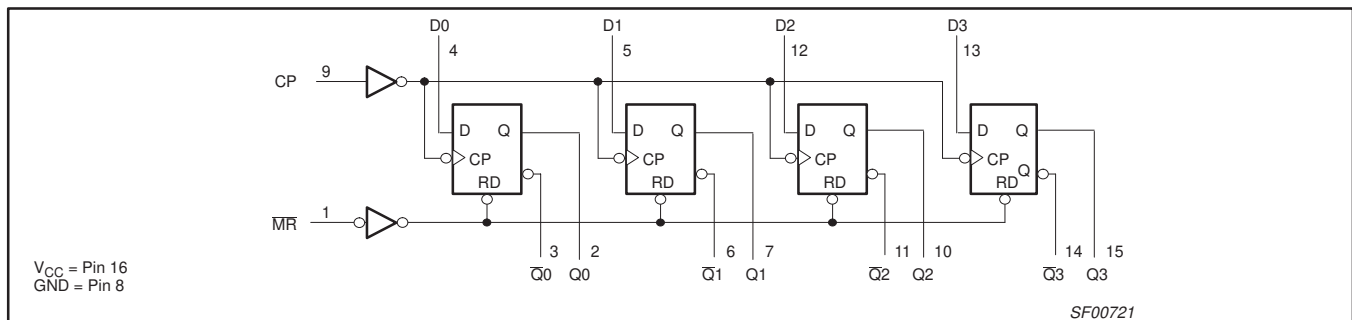

FUNCTION TABLE

INPUTS			OUTPUTS		OPERATING MODE
MR	CP	D _n	Q _n	\bar{Q}_n	
L	X	X	L	H	Reset (clear)
H	↑	h	H	L	Load "1"
H	↑	l	L	H	Load "0"

- H = High voltage level
- h = High state must be present one setup time before the Low-to-High clock transition
- L = Low voltage level
- l = Low state must be present one setup time before the Low-to-High clock transition
- X = Don't care
- ↑ = Low-to-High clock transition

ABSOLUTE MAXIMUM RATINGS

(Operation beyond the limit set forth in this table may impair the useful life of the device. Unless otherwise noted these limits are over the operating free air temperature range.)

SYMBOL	PARAMETER		RATING	UNIT	
V _{CC}	Supply voltage		-0.5 to +7.0	V	
V _{IN}	Input voltage		-0.5 to +7.0	V	
I _{IN}	Input current		-30 to +5	mA	
V _{OUT}	Voltage applied to output in High output state		-0.5 to V _{CC}	V	
I _{OUT}	Current applied to output in Low output state		40	mA	
T _{amb}	Operating free air temperature range		Commercial range	0 to +70	°C
			Industrial range	-40 to +85	°C
T _{stg}	Storage temperature range		-65 to +150	°C	

Quad D flip-flop

74F175A

RECOMMENDED OPERATING CONDITIONS

SYMBOL	PARAMETER	LIMITS			UNIT
		MIN	NOM	MAX	
V _{CC}	Supply voltage	4.5	5.0	5.5	V
V _{IH}	High-level input voltage	2.0			V
V _{IL}	Low-level input voltage			0.8	V
I _{IK}	Input clamp current			-18	mA
I _{OH}	High-level output current			-1	mA
I _{OL}	Low-level output current			20	mA
T _{amb}	Operating free air temperature range	Commercial range	0	+70	°C
		Industrial range	-40	+85	°C

DC ELECTRICAL CHARACTERISTICS

(Over recommended operating free-air temperature range unless otherwise noted.)

SYMBOL	PARAMETER	TEST CONDITIONS ¹	LIMITS			UNIT
			MIN	TYP ²	MAX	
V _{OH}	High-level output voltage	V _{CC} = MIN, V _{IL} = MAX, V _{IH} = MIN, I _{OH} = MAX	± 10%V _{CC}	2.5		V
			± 5%V _{CC}	2.7	3.4	
V _{OL}	Low-level output voltage	V _{CC} = MIN, V _{IL} = MAX, V _{IH} = MIN, I _{OL} = MAX	± 10%V _{CC}		0.30	V
			± 5%V _{CC}		0.30	
V _{IK}	Input clamp voltage	V _{CC} = MIN, I _I = I _{IK}		-0.73	-1.2	V
I _I	Input current at maximum input voltage	V _{CC} = 0.0V, V _I = 7.0V			100	μA
I _{IH}	High-level input current	V _{CC} = MAX, V _I = 2.7V			20	μA
I _{IL}	Low-level input current	V _{CC} = MAX, V _I = 0.5V			-20	μA
I _{OS}	Short-circuit output current ³	V _{CC} = MAX	-60		-150	mA
I _{CC}	Supply current (total)	V _{CC} = MAX		22	31	mA

Notes to DC electrical characteristics

- For conditions shown as MIN or MAX, use the appropriate value specified under recommended operating conditions for the applicable type.
- All typical values are at V_{CC} = 5V, T_{amb} = 25°C.
- Not more than one output should be shorted at a time. For testing I_{OS}, the use of high-speed test apparatus and/or sample-and-hold techniques are preferable in order to minimize internal heating and more accurately reflect operational values. Otherwise, prolonged shorting of a high output may raise the chip temperature well above normal and thereby cause invalid readings in other parameter tests. In any sequence of parameter tests, I_{OS} tests should be performed last.

AC ELECTRICAL CHARACTERISTICS

SYMBOL	PARAMETER	TEST CONDITION	LIMITS						UNIT	
			T _{amb} = 25°C V _{CC} = +5V C _L = 50pF, R _L = 500Ω			T _{amb} = 0°C to +70°C V _{CC} = +5.0V ± 10% C _L = 50pF, R _L = 500Ω		T _{amb} = -40°C to +85°C V _{CC} = +5.0V ± 10% C _L = 50pF, R _L = 500Ω		
			MIN	TYP	MAX	MIN	MAX	MIN		MAX
f _{max}	Maximum clock frequency	Waveform 1	140	160		125		110		MHz
t _{PLH} t _{PHL}	Propagation delay CP to Qn or Qn	Waveform 1	3.0	4.0	6.5	2.5	7.5	2.5	8.0	ns
			4.5	6.0	8.5	4.0	9.0	4.0	10.0	
t _{PLH} t _{PHL}	Propagation delay MR to Qn	Waveform 3	4.5	6.5	9.0	4.5	10.0	4.5	11.0	ns
			4.5	6.0	8.0	4.0	9.0	4.0	10.0	
t _{PHL} t _{PHL}	Propagation delay MR to Qn	Waveform 3	4.5	6.0	8.0	4.0	9.0	4.0	10.0	ns
			4.5	6.0	8.0	4.0	9.0	4.0	10.0	

Quad D flip-flop

74F175A

AC SETUP REQUIREMENTS

SYMBOL	PARAMETER	TEST CONDITION	LIMITS						UNIT		
			$T_{amb} = 25^{\circ}\text{C}$ $V_{CC} = +5\text{V}$ $C_L = 50\text{pF}$, $R_L = 500\Omega$			$T_{amb} = 0^{\circ}\text{C to } +70^{\circ}\text{C}$ $V_{CC} = +5.0\text{V} \pm 10\%$ $C_L = 50\text{pF}$, $R_L = 500\Omega$		$T_{amb} = -40^{\circ}\text{C to } +85^{\circ}\text{C}$ $V_{CC} = +5.0\text{V} \pm 10\%$ $C_L = 50\text{pF}$, $R_L = 500\Omega$			
			MIN	TYP	MAX	MIN	MAX	MIN		MAX	
$t_s(H)$ $t_s(L)$	Setup time, High or Low Dn to CP	Waveform 2	3.0			3.5			4.0		ns
$t_h(H)$ $t_h(L)$	Hold time, High or Low Dn to CP	Waveform 2	0.0			0.0			0.0		ns
$t_w(H)$ $t_w(L)$	CP Pulse width High or Low	Waveform 1	3.0			3.5			4.0		ns
$t_w(L)$	MR Pulse width Low	Waveform 3	3.5			3.5			4.0		ns
t_{REC}	Recovery time MR to CP	Waveform 3	4.0			4.5			5.0		ns

AC WAVEFORMS

For all waveforms, $V_M = 1.3\text{V}$.

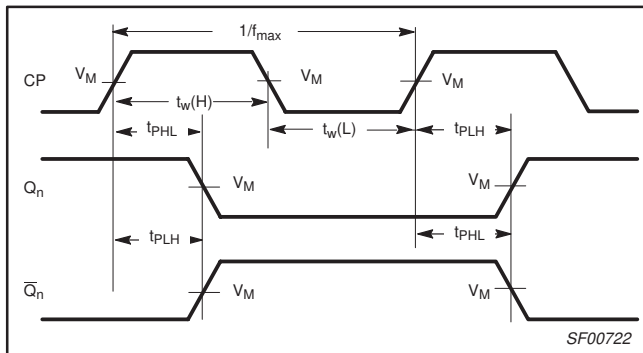

Waveform 1. Propagation delay for clock input to output, clock pulse width, and maximum clock frequency

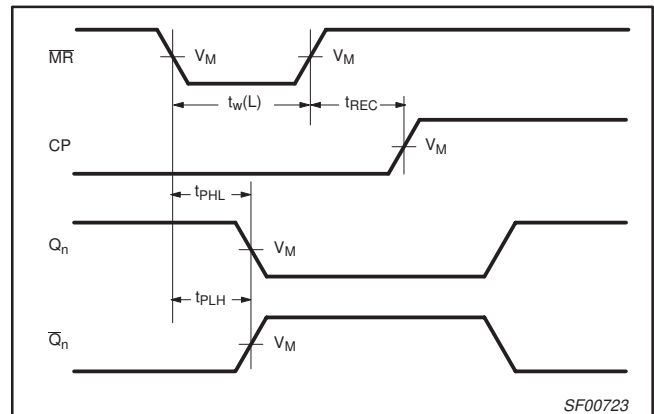

Waveform 3. Master Reset pulse width, Master Reset to output delay and Master Reset to Clock recovery time

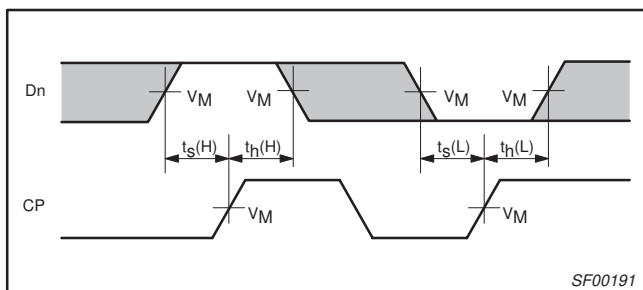

Waveform 2. Data setup time and hold times

Quad D flip-flop

74F175A

TEST CIRCUIT AND WAVEFORMS

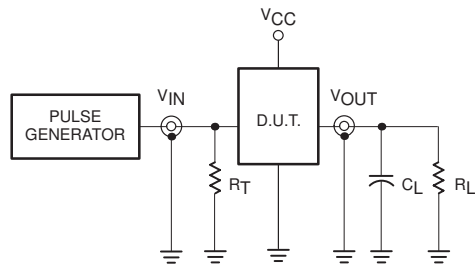

Test Circuit for Totem-Pole Outputs

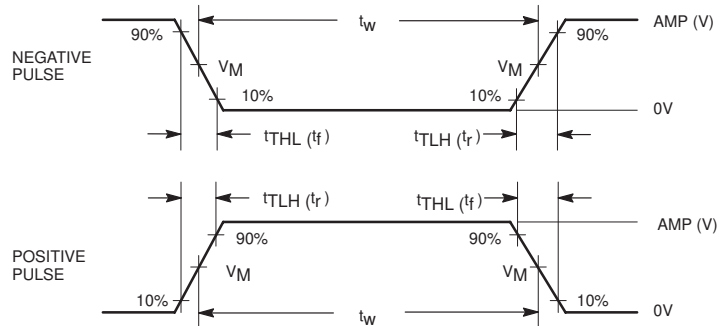

Input Pulse Definition

DEFINITIONS:

- R_L = Load resistor; see AC ELECTRICAL CHARACTERISTICS for value.
- C_L = Load capacitance includes jig and probe capacitance; see AC ELECTRICAL CHARACTERISTICS for value.
- R_T = Termination resistance should be equal to Z_{OUT} of pulse generators.

family	INPUT PULSE REQUIREMENTS					
	amplitude	V_M	rep. rate	t_w	t_{TLH}	t_{THL}
74F	3.0V	1.5V	1MHz	500ns	2.5ns	2.5ns

SF00006

Quad D flip-flop

74F175A

DIP16: plastic dual in-line package; 16 leads (300 mil)

SOT38-4



DIMENSIONS (inch dimensions are derived from the original mm dimensions)

UNIT	A max.	A ₁ min.	A ₂ max.	b	b ₁	b ₂	c	D ⁽¹⁾	E ⁽¹⁾	e	e ₁	L	M _E	M _H	w	Z ⁽¹⁾ max.
mm	4.2	0.51	3.2	1.73 1.30	0.53 0.38	1.25 0.85	0.36 0.23	19.50 18.55	6.48 6.20	2.54	7.62	3.60 3.05	8.25 7.80	10.0 8.3	0.254	0.76
inches	0.17	0.020	0.13	0.068 0.051	0.021 0.015	0.049 0.033	0.014 0.009	0.77 0.73	0.26 0.24	0.10	0.30	0.14 0.12	0.32 0.31	0.39 0.33	0.01	0.030

Note

1. Plastic or metal protrusions of 0.25 mm maximum per side are not included.

OUTLINE VERSION	REFERENCES				EUROPEAN PROJECTION	ISSUE DATE
	IEC	JEDEC	EIAJ			
SOT38-4						92-11-17 95-01-14

Quad D flip-flop

74F175A

SO16: plastic small outline package; 16 leads; body width 3.9 mm

SOT109-1

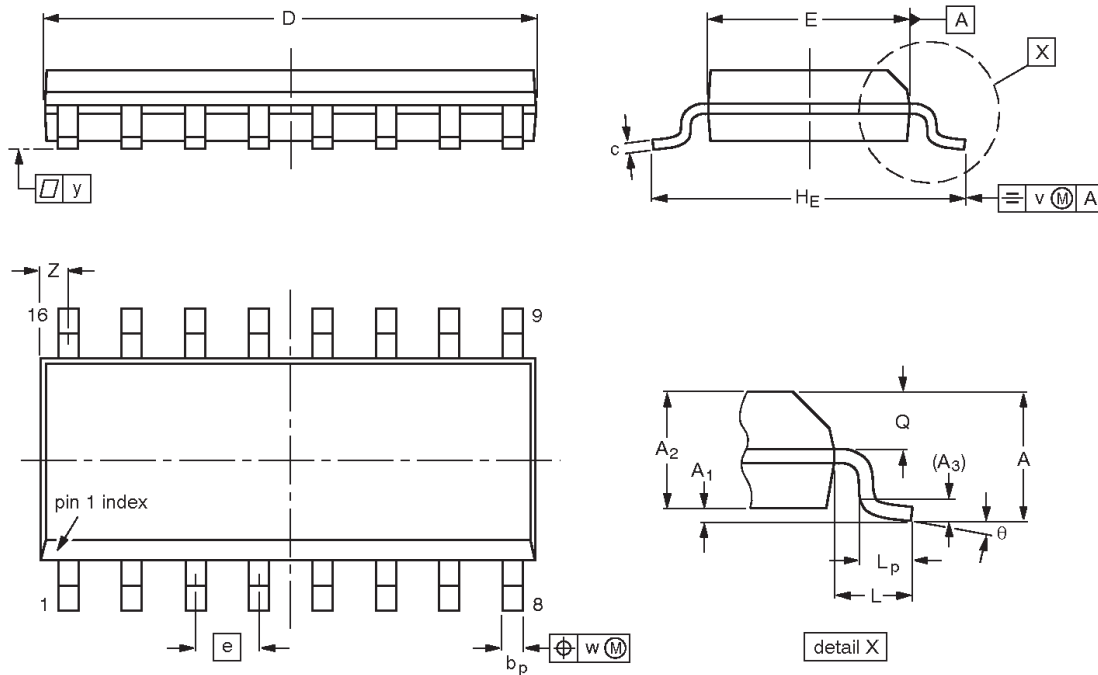

DIMENSIONS (inch dimensions are derived from the original mm dimensions)

UNIT	A max.	A ₁	A ₂	A ₃	b _p	c	D ⁽¹⁾	E ⁽¹⁾	e	H _E	L	L _p	Q	v	w	y	Z ⁽¹⁾	θ
mm	1.75	0.25 0.10	1.45 1.25	0.25	0.49 0.36	0.25 0.19	10.0 9.8	4.0 3.8	1.27	6.2 5.8	1.05	1.0 0.4	0.7 0.6	0.25	0.25	0.1	0.7 0.3	8° 0°
inches	0.069	0.010 0.004	0.057 0.049	0.01	0.019 0.014	0.0100 0.0075	0.39 0.38	0.16 0.15	0.050	0.244 0.228	0.041	0.039 0.016	0.028 0.020	0.01	0.01	0.004	0.028 0.012	

Note

1. Plastic or metal protrusions of 0.15 mm maximum per side are not included.

OUTLINE VERSION	REFERENCES				EUROPEAN PROJECTION	ISSUE DATE
	IEC	JEDEC	EIAJ			
SOT109-1	076E07S	MS-012AC				95-01-23 97-05-22

Quad D flip-flop

74F175A

NOTES

Quad D flip-flop

74F175A

Data sheet status

Data sheet status	Product status	Definition [1]
Objective specification	Development	This data sheet contains the design target or goal specifications for product development. Specification may change in any manner without notice.
Preliminary specification	Qualification	This data sheet contains preliminary data, and supplementary data will be published at a later date. Philips Semiconductors reserves the right to make changes at any time without notice in order to improve design and supply the best possible product.
Product specification	Production	This data sheet contains final specifications. Philips Semiconductors reserves the right to make changes at any time without notice in order to improve design and supply the best possible product.

[1] Please consult the most recently issued datasheet before initiating or completing a design.

Definitions

Short-form specification — The data in a short-form specification is extracted from a full data sheet with the same type number and title. For detailed information see the relevant data sheet or data handbook.

Limiting values definition — Limiting values given are in accordance with the Absolute Maximum Rating System (IEC 134). Stress above one or more of the limiting values may cause permanent damage to the device. These are stress ratings only and operation of the device at these or at any other conditions above those given in the Characteristics sections of the specification is not implied. Exposure to limiting values for extended periods may affect device reliability.

Application information — Applications that are described herein for any of these products are for illustrative purposes only. Philips Semiconductors make no representation or warranty that such applications will be suitable for the specified use without further testing or modification.

Disclaimers

Life support — These products are not designed for use in life support appliances, devices or systems where malfunction of these products can reasonably be expected to result in personal injury. Philips Semiconductors customers using or selling these products for use in such applications do so at their own risk and agree to fully indemnify Philips Semiconductors for any damages resulting from such application.

Right to make changes — Philips Semiconductors reserves the right to make changes, without notice, in the products, including circuits, standard cells, and/or software, described or contained herein in order to improve design and/or performance. Philips Semiconductors assumes no responsibility or liability for the use of any of these products, conveys no license or title under any patent, copyright, or mask work right to these products, and makes no representations or warranties that these products are free from patent, copyright, or mask work right infringement, unless otherwise specified.

Philips Semiconductors
811 East Arques Avenue
P.O. Box 3409
Sunnyvale, California 94088-3409
Telephone 800-234-7381

© Copyright Philips Electronics North America Corporation 2000
All rights reserved. Printed in U.S.A.

Date of release: 06-00

Document order number:

9397-750 07531

Let's make things better.