



Chipsmall Limited consists of a professional team with an average of over 10 year of expertise in the distribution of electronic components. Based in Hongkong, we have already established firm and mutual-benefit business relationships with customers from,Europe,America and south Asia,supplying obsolete and hard-to-find components to meet their specific needs.

With the principle of “Quality Parts,Customers Priority,Honest Operation,and Considerate Service”,our business mainly focus on the distribution of electronic components. Line cards we deal with include Microchip,ALPS,ROHM,Xilinx,Pulse,ON,Everlight and Freescale. Main products comprise IC,Modules,Potentiometer,IC Socket,Relay,Connector.Our parts cover such applications as commercial,industrial, and automotives areas.

We are looking forward to setting up business relationship with you and hope to provide you with the best service and solution. Let us make a better world for our industry!



Contact us

Tel: +86-755-8981 8866 Fax: +86-755-8427 6832

Email & Skype: info@chipsmall.com Web: www.chipsmall.com

Address: A1208, Overseas Decoration Building, #122 Zhenhua RD., Futian, Shenzhen, China



DATA SHEET

74F269

8-bit bidirectional binary counter

Product specification

1996 Jan 05

IC15 Data Handbook

8-bit bidirectional binary counter

74F269

FEATURES

- Synchronous counting and loading
- Built-in look-ahead carry capability
- Count frequency 115MHz typ
- Supply current 95mA typ

DESCRIPTION

The 74F269 is a fully synchronous 8-stage Up/Down Counter featuring a preset capability for programmable operation, carry look-ahead for easy cascading and a U/D input to control the direction of counting. All state changes, whether in counting or parallel loading, are initiated by the rising edge of the clock.

TYPE	TYPICAL f _{MAX}	TYPICAL SUPPLY CURRENT (TOTAL)
74F269	115MHz	95mA

PIN CONFIGURATION

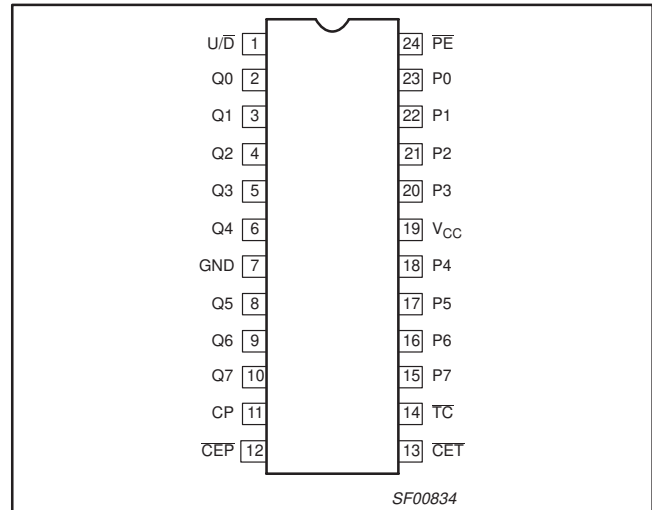

ORDERING INFORMATION

DESCRIPTION	COMMERCIAL RANGE V _{CC} = 5V ±10%, T _{amb} = 0°C to +70°C	PKG DWG #
24-Pin Plastic Slim DIP (300mil)	N74F269N	SOT222-1
24-Pin Plastic SOL	N74F269D	SOT137-1
24-Pin Plastic SSOP type II	N74F269DB	SOT340-1

INPUT AND OUTPUT LOADING AND FAN-OUT TABLE

PINS	DESCRIPTION	74F(U.L.) HIGH/LOW	LOAD VALUE HIGH/LOW
P0 - P7	Parallel Data inputs	1.0/1.0	20µA/0.6mA
PE	Parallel Enable input (active Low)	1.0/1.0	20µA/0.6mA
U/D	Up/Down count control input	1.0/1.0	20µA/0.6mA
CEP	Count Enable Parallel input (active Low)	1.0/1.0	20µA/0.6mA
CET	Count Enable Trickle input (active Low)	1.0/1.0	20µA/0.6mA
CP	Clock input	1.0/1.0	20µA/0.6mA
TC	Terminal Count output (active Low)	50/33	1.0mA/20mA
Q0 - Q7	Flip-flop outputs	50/33	1.0mA/20mA

NOTE:

One (1.0) FAST Unit Load is defined as: 20µA in the High state and 0.6mA in the Low state.

8-bit bidirectional binary counter

74F269

LOGIC SYMBOL

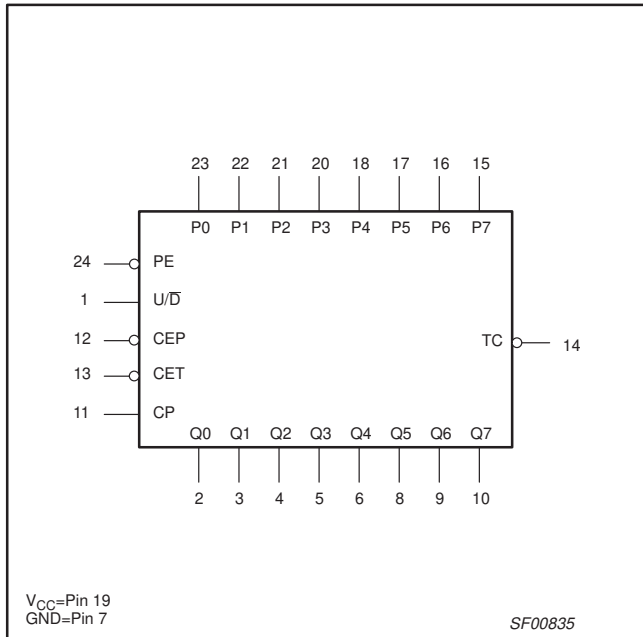

LOGIC SYMBOL (IEEE/IEC)

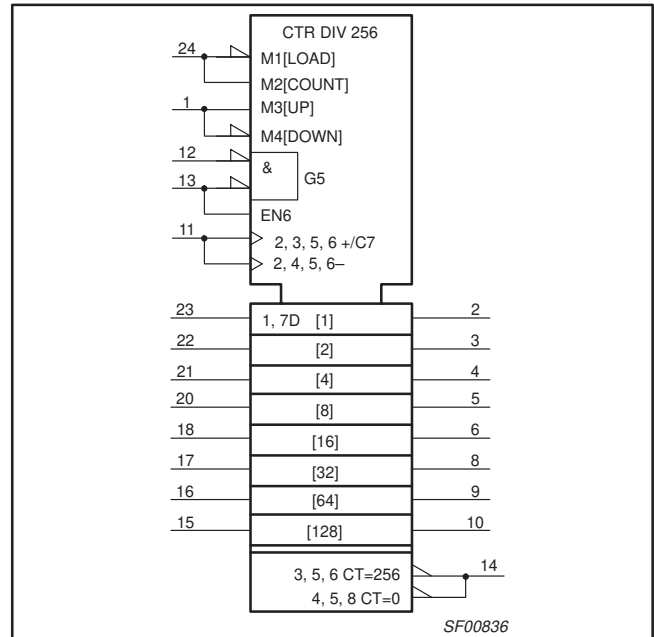

APPLICATION

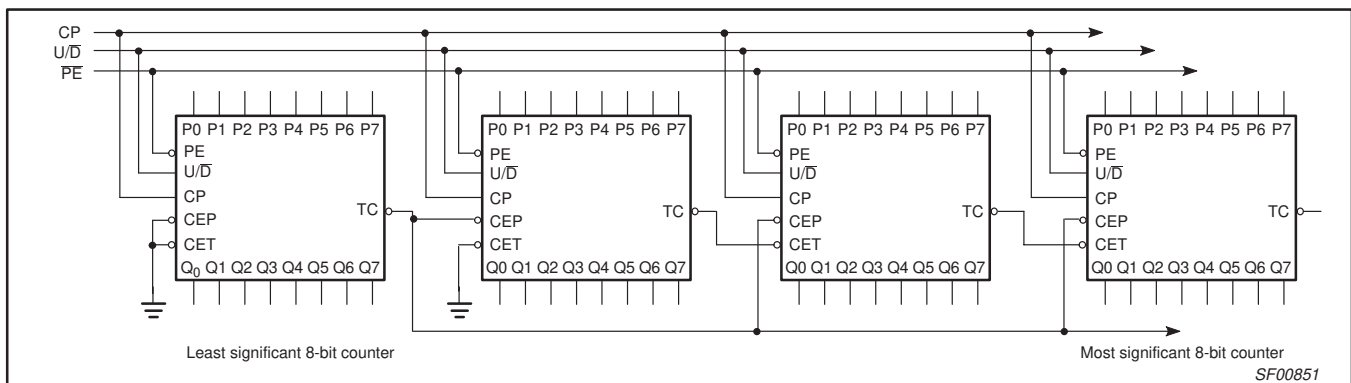

Figure 1. Synchronous Multistage Counting Scheme

MODE SELECT FUNCTION TABLE

INPUTS						OUTPUTS		OPERATING MODE
CP	U/D	CEP	CET	PE	P _n	Q _n	TC	
↑	X	X	X	l	l	L	(a)	Parallel load
↑	X	X	X	l	h	H	(a)	
↑	h	l	l	h	X	Count Up	(a)	Count Up
↑	l	l	l	h	X	Count Down	(a)	Count Down
↑	X	h	l	h	X	q _n	(a)	Hold (do nothing)
↑	X	X	h	h	X	q _n	H	

H = High voltage level

h = High voltage level one setup prior to the Low-to-High clock transition

L = Low voltage level

l = Low voltage level one setup time prior to the Low-to-High clock transition

q = Lower case letters indicate the state of the referenced output prior to the Low-to-High clock transition

X = Don't care

↑ = Low-to-High clock transition

(a) = TC is Low when CET is Low and the counter is at Terminal Count. Terminal Count Up is with all Q_n outputs High and Terminal Count Down is with all Q_n outputs Low.

8-bit bidirectional binary counter

74F269

LOGIC DIAGRAM

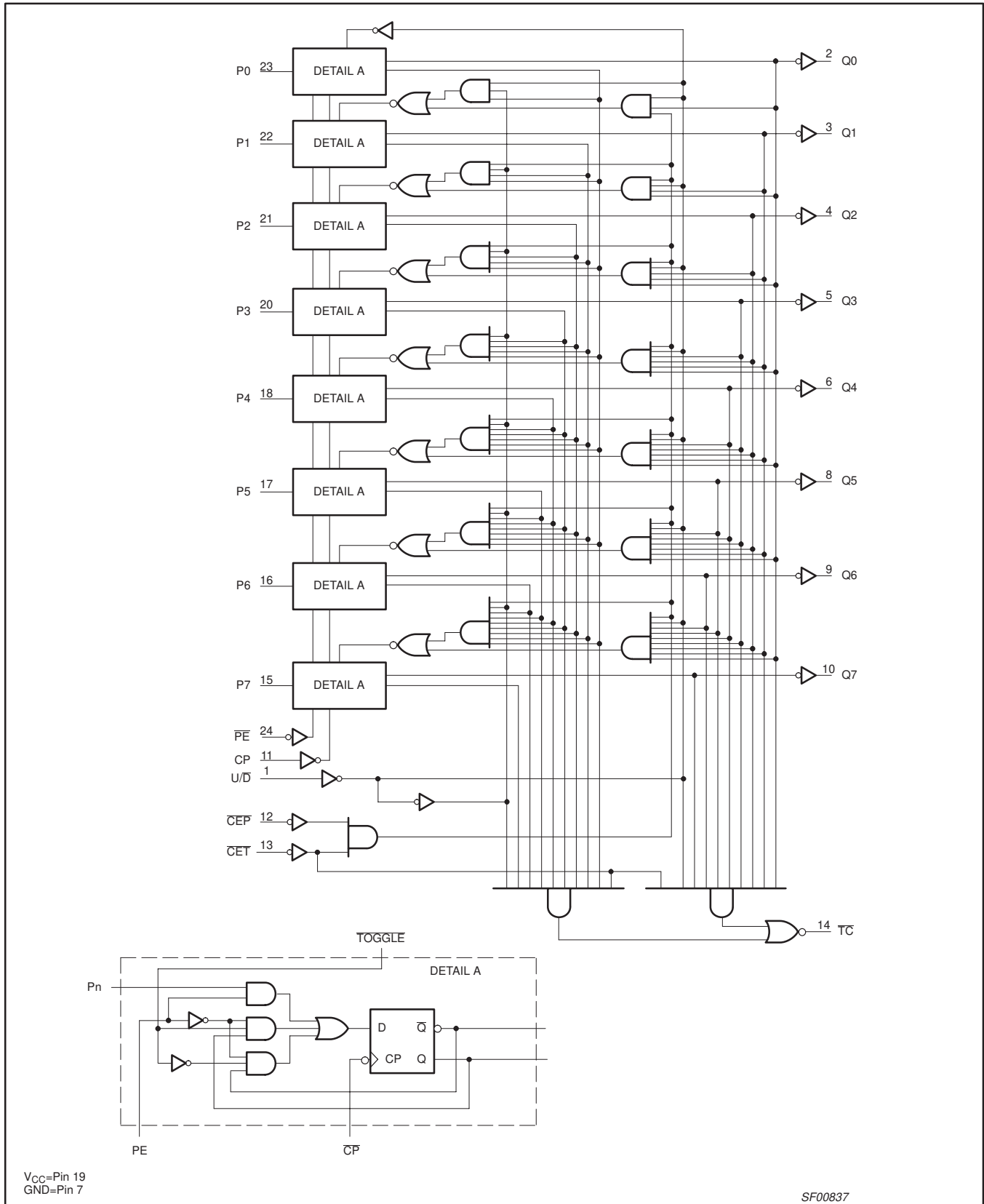

8-bit bidirectional binary counter

74F269

ABSOLUTE MAXIMUM RATINGS

(Operation beyond the limits set forth in this table may impair the useful life of the device.
Unless otherwise noted these limits are over the operating free-air temperature range.)

SYMBOL	PARAMETER	RATING	UNIT
V _{CC}	Supply voltage	-0.5 to +7.0	V
V _{IN}	Input voltage	-0.5 to +7.0	V
I _{IN}	Input current	-30 to +5	mA
V _{OUT}	Voltage applied to output in High output state	-0.5 to V _{CC}	V
I _{OUT}	Current applied to output in Low output state	40	mA
T _{amb}	Operating free-air temperature range	0 to +70	°C
T _{stg}	Storage temperature	-65 to +150	°C

RECOMMENDED OPERATING CONDITIONS

SYMBOL	PARAMETER	LIMITS			UNIT
		MIN	NOM	MAX	
V _{CC}	Supply voltage	4.5	5.0	5.5	V
V _{IH}	High-level input voltage	2.0			V
V _{IL}	Low-level input voltage			0.8	V
I _{IK}	Input clamp current			-18	mA
I _{OH}	High-level output current			-1	mA
I _{OL}	Low-level output current			20	mA
T _{amb}	Operating free-air temperature range	0		70	°C

DC ELECTRICAL CHARACTERISTICS

(Over recommended operating free-air temperature range unless otherwise noted.)

SYMBOL	PARAMETER	TEST CONDITIONS ^{NO TAG}	LIMITS			UNIT	
			MIN	TYP NO TAG	MAX		
V _{OH}	High-level output voltage	V _{CC} = MIN, V _{IL} = MAX	±10%V _{CC}	2.5		V	
		V _{IH} = MIN, I _{OH} = MAX	±5%V _{CC}	2.7	3.4		
V _{OL}	Low-level output voltage	V _{CC} = MIN, V _{IL} = MAX	±10%V _{CC}		0.30	V	
		V _{IH} = MIN, I _{OL} = MAX	±5%V _{CC}		0.30		
V _{IK}	Input clamp voltage	V _{CC} = MIN, I _I = I _{IK}			-0.73	V	
I _I	Input current at maximum input voltage	V _{CC} = MAX, V _I = 7.0V			100	μA	
I _{IH}	High-level input current	V _{CC} = MAX, V _I = 2.7V			20	μA	
I _{IL}	Low-level input current	V _{CC} = MAX, V _I = 0.5V			-0.6	mA	
I _{OS}	Short-circuit output current ^{NO TAG}	V _{CC} = MAX		-60		mA	
I _{CC}	Supply current (total)	I _{CCH}	V _{CC} = MAX	PE=CET=CEP=U/D=GND, Pn=4.5V, CP=↑	93	120	mA
		I _{CCL}			98	125	mA

NOTES:

- For conditions shown as MIN or MAX, use the appropriate value specified under recommended operating conditions for the applicable type.
- All typical values are at V_{CC} = 5V, T_{amb} = 25°C.
- Not more than one output should be shorted at a time. For testing I_{OS}, the use of high-speed test apparatus and/or sample-and-hold techniques are preferable in order to minimize internal heating and more accurately reflect operational values. Otherwise, prolonged shorting of a High output may raise the chip temperature well above normal and thereby cause invalid readings in other parameter tests. In any sequence of parameter tests, I_{OS} tests should be performed last.

8-bit bidirectional binary counter

74F269

AC ELECTRICAL CHARACTERISTICS

SYMBOL	PARAMETER	TEST CONDITIONS	LIMITS					UNIT
			$T_{amb} = +25^{\circ}\text{C}$ $V_{CC} = +5\text{V}$ $C_L = 50\text{pF}, R_L = 500\Omega$			$T_{amb} = 0^{\circ}\text{C to } +70^{\circ}\text{C}$ $V_{CC} = +5\text{V} \pm 10\%$ $C_L = 50\text{pF}, R_L = 500\Omega$		
			MIN	TYP	MAX	MIN	MAX	
f_{MAX}	Maximum clock frequency	Waveform 1	100	115		85		MHz
t_{PLH} t_{pPHL}	Propagation delay CP to Q_n (Load, $\overline{PE} = \text{Low}$)	Waveform 1	3.0 4.0	6.0 6.5	8.5 8.5	3.0 4.0	9.0 9.0	ns ns
t_{PLH} t_{PHL}	Propagation delay CP to Q_n (Count, $\overline{PE} = \text{High}$)	Waveform 1	3.0 4.5	6.0 7.0	9.0 10.0	3.0 4.0	10.0 10.5	ns ns
t_{PLH} t_{PHL}	Propagation delay CP to \overline{TC}	Waveform 1	4.5 5.0	6.5 6.5	9.5 9.5	4.0 5.0	10.5 10.0	ns ns
t_{PLH} t_{PHL}	Propagation delay \overline{CET} to \overline{TC}	Waveform 2	3.5 3.0	6.0 6.5	9.0 9.0	3.0 3.0	10.0 10.0	ns ns
t_{PLH} t_{PHL}	Propagation delay U/D to \overline{TC}	Waveform 3	4.5 4.5	7.0 7.0	9.0 9.5	4.0 4.0	10.0 10.0	ns ns

AC SETUP REQUIREMENTS

SYMBOL	PARAMETER	TEST CONDITIONS	LIMITS				UNIT
			$T_{amb} = +25^{\circ}\text{C}$ $V_{CC} = +5\text{V}$ $C_L = 50\text{pF}, R_L = 500\Omega$		$T_{amb} = 0^{\circ}\text{C to } +70^{\circ}\text{C}$ $V_{CC} = +5\text{V} \pm 10\%$ $C_L = 50\text{pF}, R_L = 500\Omega$		
			MIN	TYP	MIN	MAX	
$t_s(H)$ $t_s(L)$	Setup time, High or Low P_n to CP	Waveform 4	3.5 3.5		2.5 2.5		ns ns
$t_h(H)$ $t_h(L)$	Hold time, High or Low P_n to CP	Waveform 4	1.0 1.0		0 1.0		ns ns
$t_s(H)$ $t_s(L)$	Setup time, High or Low \overline{PE} to CP	Waveform 4	5.5 6.5		5.5 6.5		ns ns
$t_h(H)$ $t_h(L)$	Hold time, High or Low \overline{PE} to CP	Waveform 4	0 0		0 0		ns ns
$t_s(H)$ $t_s(L)$	Setup time, High or Low \overline{CEP} or \overline{CET} to CP	Waveform 5	6.0 8.0		5.0 6.5		ns ns
$t_h(H)$ $t_h(L)$	Hold time, High or Low \overline{CEP} or \overline{CET} to CP	Waveform 5	0 0		0 0		ns ns
$t_s(H)$ $t_s(L)$	Setup time, High or Low U/D to CP	Waveform 6	8.0 6.5		6.5 6.5		ns ns
$t_h(H)$ $t_h(L)$	Hold time, High or Low U/D to CP	Waveform 6	0 0		0 0		ns ns
$t_w(H)$ $t_w(L)$	\overline{CP} Pulse width High or Low	Waveform 1	4.0 4.5		4.0 5.0		ns ns

8-bit bidirectional binary counter

74F269

TIMING DIAGRAM

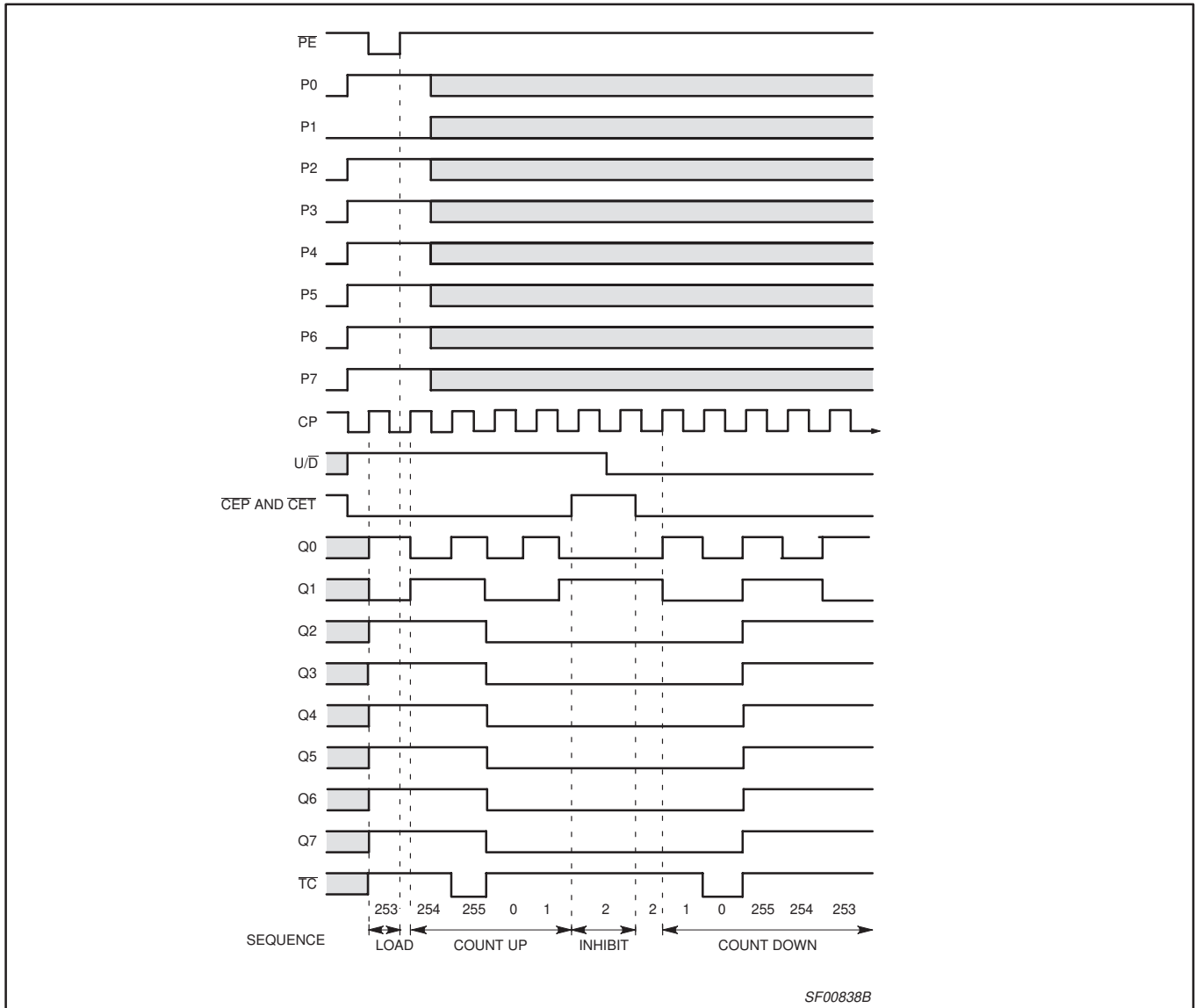

8-bit bidirectional binary counter

74F269

AC WAVEFORMS

For all waveforms, $V_M = 1.5V$.

The shaded areas indicate when the input is permitted to change for predictable output performance.

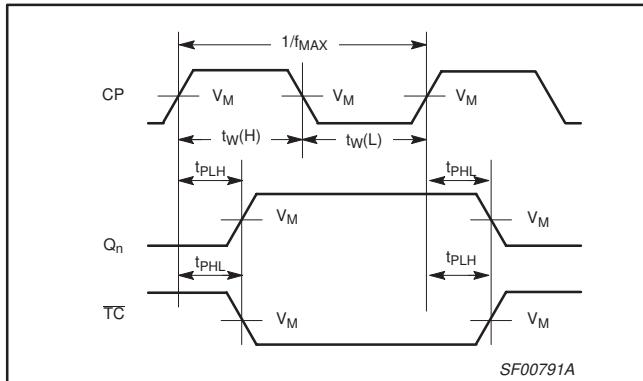

Waveform 1. Propagation Delay, Clock Input to Output, Clock Pulse Width, and Maximum Clock Frequency

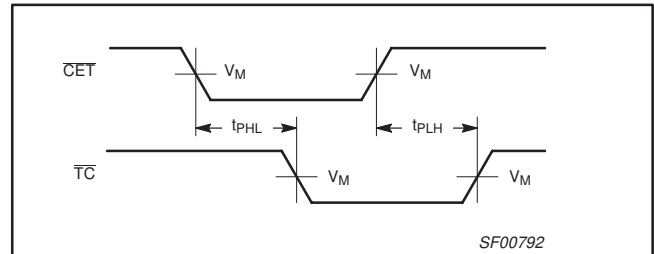

Waveform 2. Propagation Delay, CET Input to Terminal Count Output

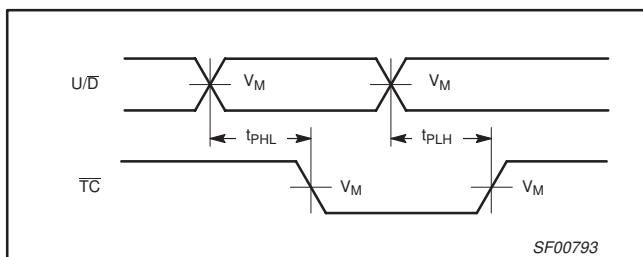

Waveform 3. Propagation Delay, Up/Down Count Control Input to Terminal Count Output

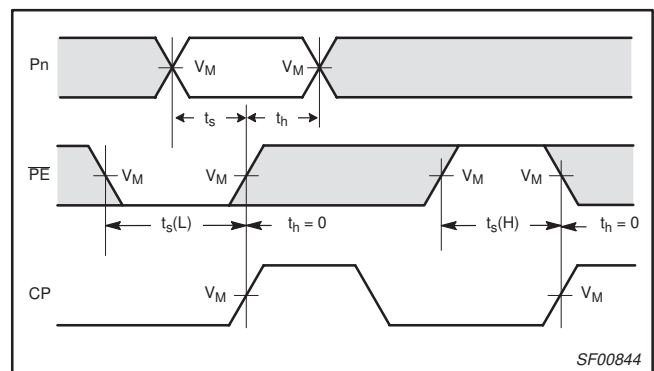

Waveform 4. Parallel Data and Parallel Enable Setup and Hold Times

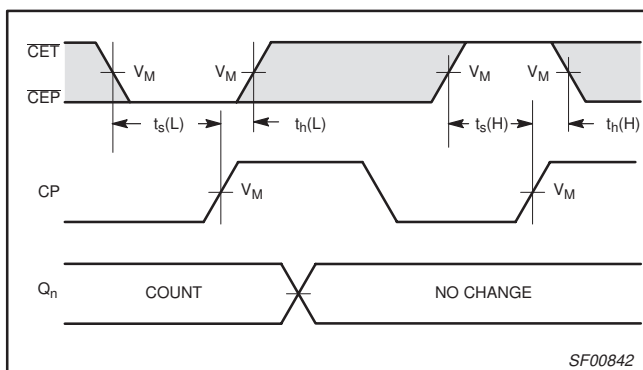

Waveform 5. Count Enables Setup and Hold Times

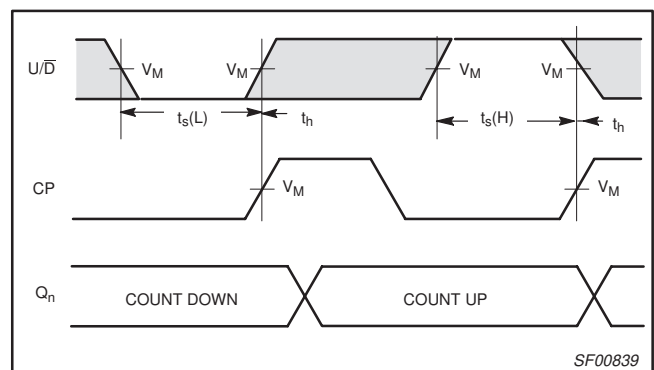

Waveform 6. Up/Down Count Control Setup and Hold Times

8-bit bidirectional binary counter

74F269

TEST CIRCUIT AND WAVEFORMS

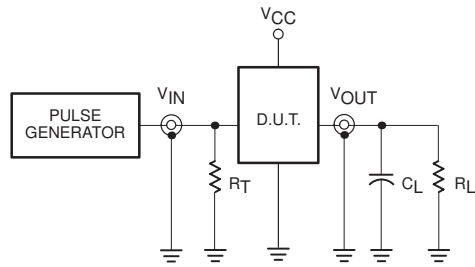

Test Circuit for Totem-Pole Outputs

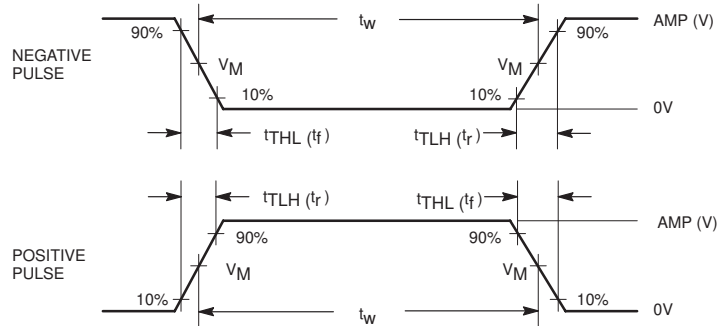

Input Pulse Definition

DEFINITIONS:

- R_L = Load resistor; see AC ELECTRICAL CHARACTERISTICS for value.
- C_L = Load capacitance includes jig and probe capacitance; see AC ELECTRICAL CHARACTERISTICS for value.
- R_T = Termination resistance should be equal to Z_{OUT} of pulse generators.

family	INPUT PULSE REQUIREMENTS					
	amplitude	V_M	rep. rate	t_w	t_{TLH}	t_{THL}
74F	3.0V	1.5V	1MHz	500ns	2.5ns	2.5ns

SF00006

8-bit bidirectional binary counter

74F269

DIP24: plastic dual in-line package; 24 leads (300 mil)

SOT222-1

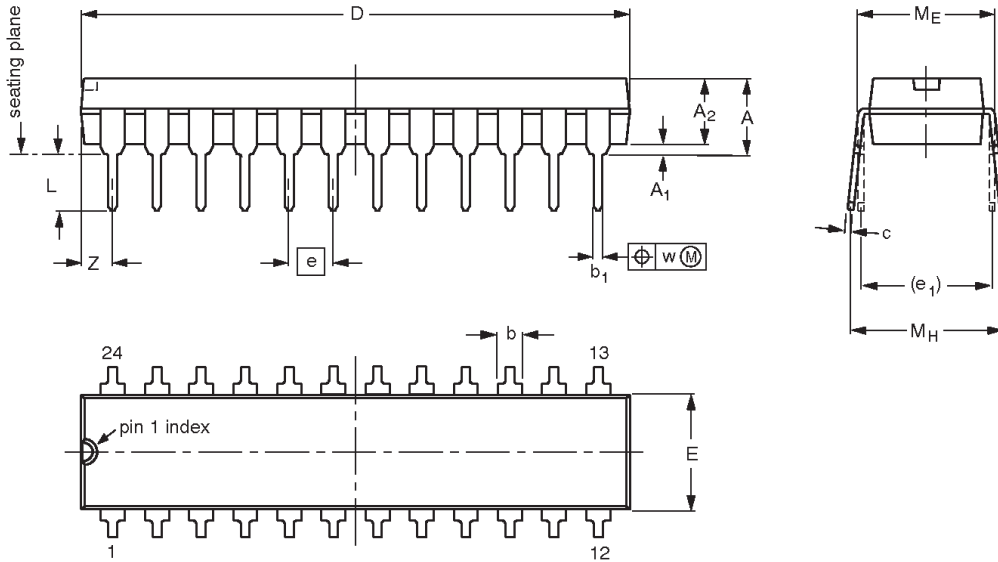

DIMENSIONS (millimetre dimensions are derived from the original inch dimensions)

UNIT	A max.	A ₁ min.	A ₂ max.	b	b ₁	c	D ⁽¹⁾	E ⁽¹⁾	e	e ₁	L	M _E	M _H	w	Z ⁽¹⁾ max.
mm	4.70	0.38	3.94	1.63 1.14	0.56 0.43	0.36 0.25	31.9 31.5	6.73 6.48	2.54	7.62	3.51 3.05	8.13 7.62	10.03 7.62	0.25	2.05
inches	0.185	0.015	0.155	0.064 0.045	0.022 0.017	0.014 0.010	1.256 1.240	0.265 0.255	0.100	0.300	0.138 0.120	0.32 0.30	0.395 0.300	0.01	0.081

Note

1. Plastic or metal protrusions of 0.01 inches maximum per side are not included.

OUTLINE VERSION	REFERENCES				EUROPEAN PROJECTION	ISSUE DATE
	IEC	JEDEC	EIAJ			
SOT222-1		MS-001AF				95-03-11

8-bit bidirectional binary counter

74F269

SO24: plastic small outline package; 24 leads; body width 7.5 mm

SOT137-1

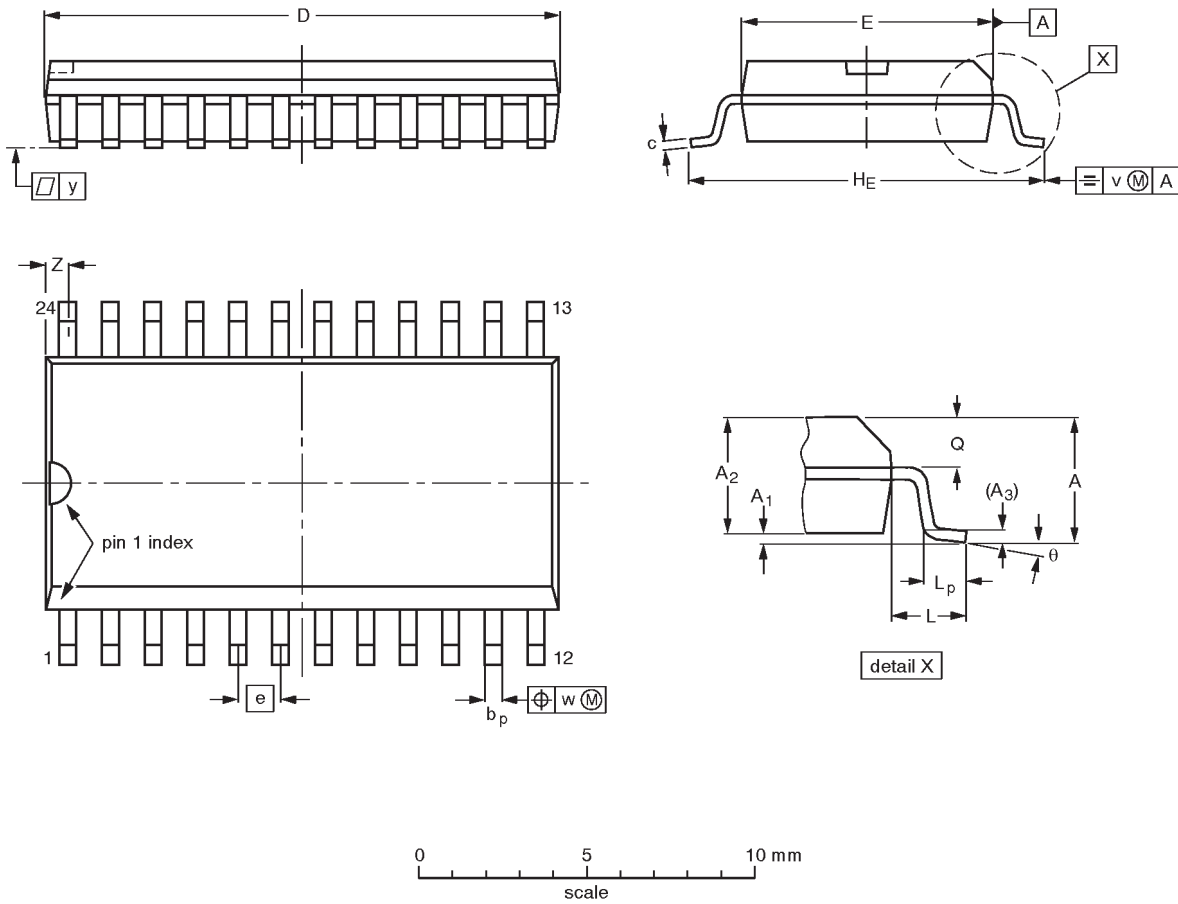

DIMENSIONS (inch dimensions are derived from the original mm dimensions)

UNIT	A max.	A ₁	A ₂	A ₃	b _p	c	D ⁽¹⁾	E ⁽¹⁾	e	H _E	L	L _p	Q	v	w	y	Z ⁽¹⁾	θ
mm	2.65	0.30 0.10	2.45 2.25	0.25	0.49 0.36	0.32 0.23	15.6 15.2	7.6 7.4	1.27	10.65 10.00	1.4	1.1 0.4	1.1 1.0	0.25	0.25	0.1	0.9 0.4	8° 0°
inches	0.10	0.012 0.004	0.096 0.089	0.01	0.019 0.014	0.013 0.009	0.61 0.60	0.30 0.29	0.050	0.42 0.39	0.055	0.043 0.016	0.043 0.039	0.01	0.01	0.004	0.035 0.016	

Note

1. Plastic or metal protrusions of 0.15 mm maximum per side are not included.

OUTLINE VERSION	REFERENCES				EUROPEAN PROJECTION	ISSUE DATE
	IEC	JEDEC	EIAJ			
SOT137-1	075E05	MS-013AD				-92-11-17 95-01-24

8-bit bidirectional binary counter

74F269

SSOP24: plastic shrink small outline package; 24 leads; body width 5.3 mm

SOT340-1

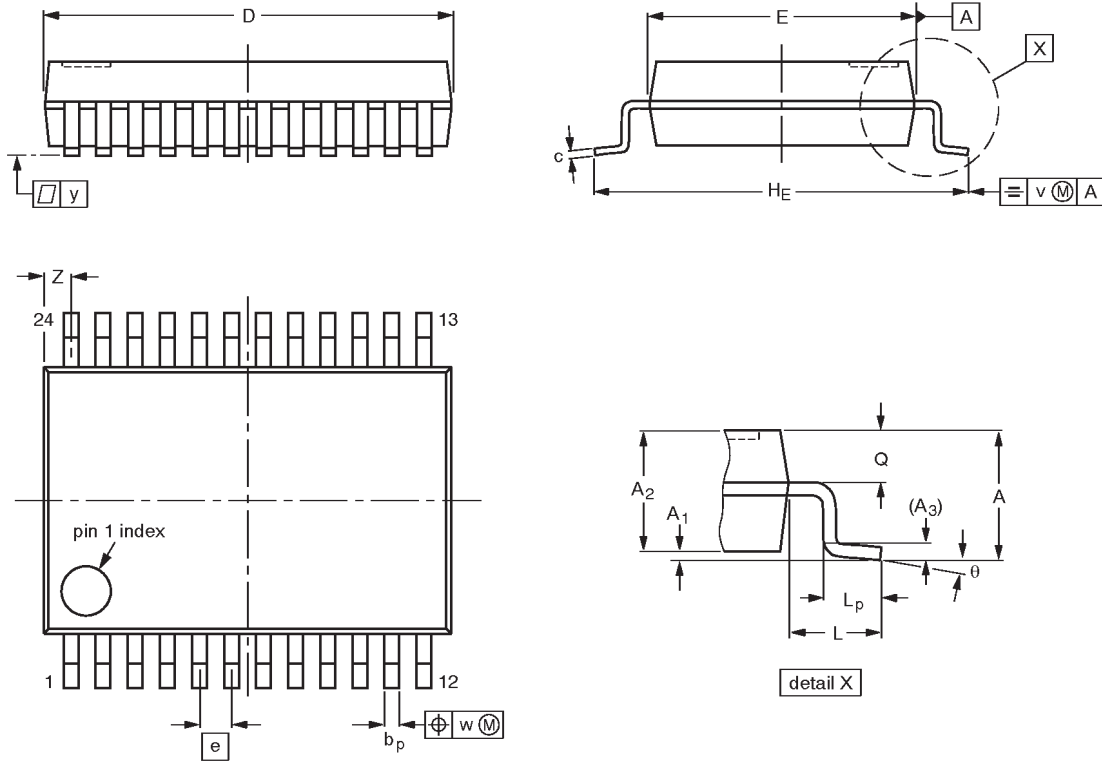

DIMENSIONS (mm are the original dimensions)

UNIT	A max.	A ₁	A ₂	A ₃	b _p	c	D ⁽¹⁾	E ⁽¹⁾	e	H _E	L	L _p	Q	v	w	y	Z ⁽¹⁾	θ
mm	2.0	0.21 0.05	1.80 1.65	0.25	0.38 0.25	0.20 0.09	8.4 8.0	5.4 5.2	0.65	7.9 7.6	1.25	1.03 0.63	0.9 0.7	0.2	0.13	0.1	0.8 0.4	8° 0°

Note

1. Plastic or metal protrusions of 0.20 mm maximum per side are not included.

OUTLINE VERSION	REFERENCES				EUROPEAN PROJECTION	ISSUE DATE
	IEC	JEDEC	EIAJ			
SOT340-1		MO-150AG				93-09-08 95-02-04

8-bit bidirectional binary counter

74F269

NOTES

8-bit bidirectional binary counter

74F269

DEFINITIONS

Data Sheet Identification	Product Status	Definition
<i>Objective Specification</i>	Formative or in Design	This data sheet contains the design target or goal specifications for product development. Specifications may change in any manner without notice.
<i>Preliminary Specification</i>	Preproduction Product	This data sheet contains preliminary data, and supplementary data will be published at a later date. Philips Semiconductors reserves the right to make changes at any time without notice in order to improve design and supply the best possible product.
<i>Product Specification</i>	Full Production	This data sheet contains Final Specifications. Philips Semiconductors reserves the right to make changes at any time without notice, in order to improve design and supply the best possible product.

Philips Semiconductors and Philips Electronics North America Corporation reserve the right to make changes, without notice, in the products, including circuits, standard cells, and/or software, described or contained herein in order to improve design and/or performance. Philips Semiconductors assumes no responsibility or liability for the use of any of these products, conveys no license or title under any patent, copyright, or mask work right to these products, and makes no representations or warranties that these products are free from patent, copyright, or mask work right infringement, unless otherwise specified. Applications that are described herein for any of these products are for illustrative purposes only. Philips Semiconductors makes no representation or warranty that such applications will be suitable for the specified use without further testing or modification.

LIFE SUPPORT APPLICATIONS

Philips Semiconductors and Philips Electronics North America Corporation Products are not designed for use in life support appliances, devices, or systems where malfunction of a Philips Semiconductors and Philips Electronics North America Corporation Product can reasonably be expected to result in a personal injury. Philips Semiconductors and Philips Electronics North America Corporation customers using or selling Philips Semiconductors and Philips Electronics North America Corporation Products for use in such applications do so at their own risk and agree to fully indemnify Philips Semiconductors and Philips Electronics North America Corporation for any damages resulting from such improper use or sale.

Philips Semiconductors
811 East Arques Avenue
P.O. Box 3409
Sunnyvale, California 94088-3409
Telephone 800-234-7381

Philips Semiconductors and Philips Electronics North America Corporation register eligible circuits under the Semiconductor Chip Protection Act.
 © Copyright Philips Electronics North America Corporation 1996
 All rights reserved. Printed in U.S.A.

(print code)

Date of release: July 1994

Document order number:

9397-750-05112