



Chipsmall Limited consists of a professional team with an average of over 10 year of expertise in the distribution of electronic components. Based in Hongkong, we have already established firm and mutual-benefit business relationships with customers from,Europe,America and south Asia,supplying obsolete and hard-to-find components to meet their specific needs.

With the principle of “Quality Parts,Customers Priority,Honest Operation,and Considerate Service”,our business mainly focus on the distribution of electronic components. Line cards we deal with include Microchip,ALPS,ROHM,Xilinx,Pulse,ON,Everlight and Freescale. Main products comprise IC,Modules,Potentiometer,IC Socket,Relay,Connector.Our parts cover such applications as commercial,industrial, and automotives areas.

We are looking forward to setting up business relationship with you and hope to provide you with the best service and solution. Let us make a better world for our industry!



Contact us

Tel: +86-755-8981 8866 Fax: +86-755-8427 6832

Email & Skype: info@chipsmall.com Web: www.chipsmall.com

Address: A1208, Overseas Decoration Building, #122 Zhenhua RD., Futian, Shenzhen, China



DATA SHEET

74F298

Quad 2-input multiplexer with storage

Product specification

1989 Aug 14

IC15 Data Handbook

Quad 2-input multiplexer with storage

74F298

FEATURES

- Fully synchronous operation
- Select from two data sources
- Buffered, negative edge triggered clock
- Provides the equivalent of function capabilities of two separate MSI functions (74F157 and 74F175)

DESCRIPTION

The 74F298 is a high speed Quad 2-Input Multiplexer with storage. It selects 4 bits of data from two sources (ports) under the control of a common Select input (S). The selected data is transferred to the 4-bit output register synchronous with the High-to-Low transition of the clock (\overline{CP}). The 4-bit register is fully edge triggered. The data inputs (I0 and I1) and Select input (S) must be stable only one setup time prior to the High-to-Low transition of the clock for predictable operation.

PIN CONFIGURATION

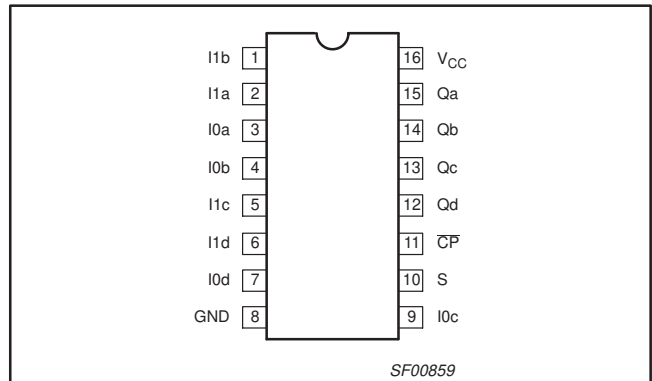

TYPE	TYPICAL f_{MAX}	TYPICAL SUPPLY CURRENT (TOTAL)
74F298	115MHz	30mA

ORDERING INFORMATION

DESCRIPTION	ORDER CODE	PKG DWG #
	COMMERCIAL RANGE $V_{CC} = 5V \pm 10\%$, $T_{amb} = 0^{\circ}C$ to $+70^{\circ}C$	
16-pin plastic DIP	N74F298N	SOT38-4
16-pin plastic SO	N74F298D	SOT109-1

INPUT AND OUTPUT LOADING AND FAN-OUT TABLE

PINS	DESCRIPTION	74F (U.L.) HIGH/LOW	LOAD VALUE HIGH/LOW
I0a, I0b, I0c, I0d	Data inputs	1.0/1.0	20 μ A/0.6mA
I1a, I1b, I1c, I1d	Data inputs	1.0/1.0	20 μ A/0.6mA
S	Select input	1.0/1.0	20 μ A/0.6mA
\overline{CP}	Clock input (active falling edge)	1.0/1.0	20 μ A/0.6mA
Qa, Qb, Qc, Qd	Data outputs	50/33	1.0mA/20mA

NOTE:

One (1.0) FAST unit load is defined as: 20 μ A in the High state and 0.6mA in the Low state.

LOGIC SYMBOL

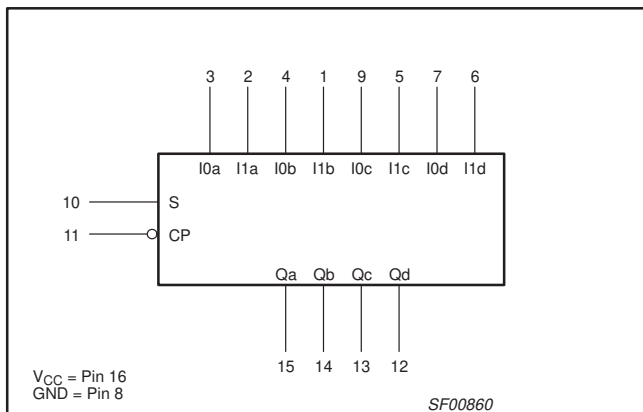

LOGIC SYMBOL (IEEE/IEC)

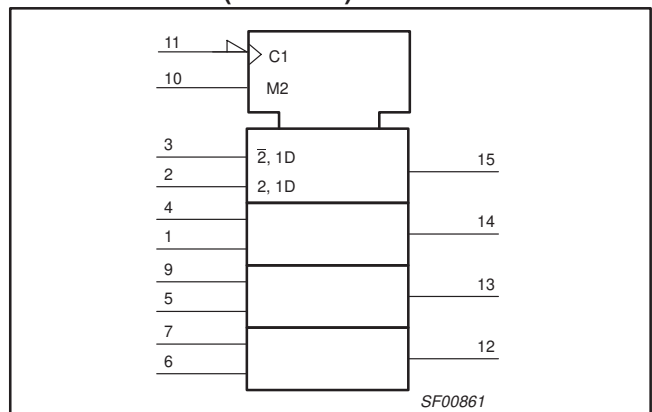

Quad 2-input multiplexer with storage

74F298

LOGIC DIAGRAM

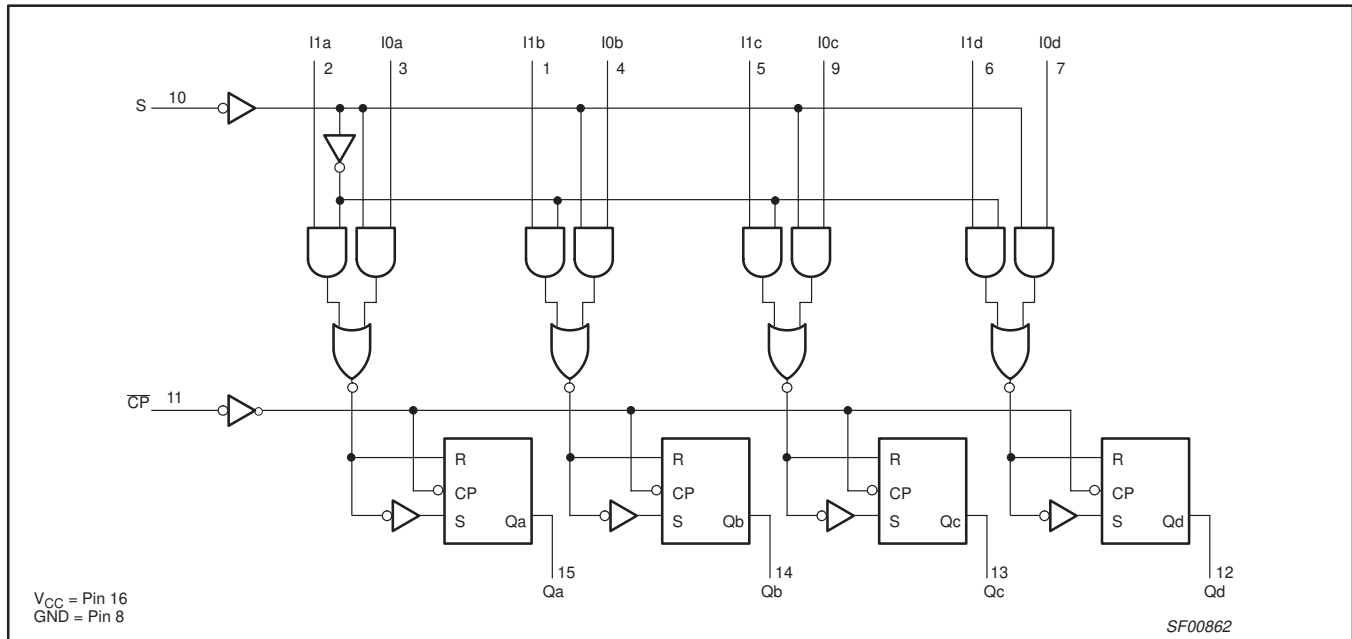

FUNCTION TABLE

INPUTS				OUTPUT	OPERATING MODE
CP	S	I0n	I1n	Qn	
↓	l	l	X	L	Load source "0"
↓	l	h	X	H	
↓	h	X	l	L	Load source "1"
↓	h	X	h	H	

- H = High voltage level
- h = High voltage level one setup time prior to the High-to-Low clock transition
- L = Low voltage level
- l = Low voltage level one setup time prior to the High-to-Low clock transition
- X = Don't care
- ↓ = High-to-Low clock transition

ABSOLUTE MAXIMUM RATINGS

(Operation beyond the limits set forth in this table may impair the useful life of the device. Unless otherwise noted these limits are over the operating free-air temperature range.)

SYMBOL	PARAMETER	RATING	UNIT
V _{CC}	Supply voltage	-0.5 to +7.0	V
V _{IN}	Input voltage	-0.5 to +7.0	V
I _{IN}	Input current	-30 to +5	mA
V _{OUT}	Voltage applied to output in High output state	-0.5 to V _{CC}	V
I _{OUT}	Current applied to output in Low output state	40	mA
T _{amb}	Operating free-air temperature range	0 to +70	°C
T _{stg}	Storage temperature range	-65 to +150	°C

Quad 2-input multiplexer with storage

74F298

RECOMMENDED OPERATING CONDITIONS

SYMBOL	PARAMETER	LIMITS			UNIT
		MIN	NOM	MAX	
V_{CC}	Supply voltage	4.5	5.0	5.5	V
V_{IH}	High-level input voltage	2.0			V
V_{IL}	Low-level input voltage			0.8	V
I_{IK}	Input clamp current			-18	mA
I_{OH}	High-level output current			-1	mA
I_{OL}	Low-level output current			20	mA
T_{amb}	Operating free-air temperature range	0		70	°C

DC ELECTRICAL CHARACTERISTICS

(Over recommended operating free-air temperature range unless otherwise noted.)

SYMBOL	PARAMETER	TEST CONDITIONS ^{NO TAG}	LIMITS			UNIT	
			MIN	TYP NO TAG	MAX		
V_{OH}	High-level output voltage	$V_{CC} = \text{MIN}, V_{IL} = \text{MAX},$ $V_{IH} = \text{MIN}, I_{OH} = -\text{MAX}$	$\pm 10\%V_{CC}$	2.5		V	
			$\pm 5\%V_{CC}$	2.7	3.4	V	
V_{OL}	Low-level output voltage	$V_{CC} = \text{MIN}, V_{IL} = \text{MAX},$ $V_{IH} = \text{MIN}, I_{OL} = -\text{MAX}$	$\pm 10\%V_{CC}$		0.30	0.50	V
			$\pm 5\%V_{CC}$		0.30	0.50	V
V_{IK}	Input clamp voltage	$V_{CC} = \text{MIN}, I_I = I_{IK}$		-0.73	-1.2	V	
I_I	Input current at maximum input voltage	$V_{CC} = \text{MAX}, V_I = 7.0V$			100	μA	
I_{IH}	High-level input current	$V_{CC} = \text{MAX}, V_I = 2.7V$			20	μA	
I_{IL}	Low-level input current	$V_{CC} = \text{MAX}, V_I = 0.5V$			-0.6	mA	
I_{OS}	Short-circuit output current ^{NO TAG}	$V_{CC} = \text{MAX}$	-60		-150	mA	
I_{CC}	Supply current (total)	$V_{CC} = \text{MAX}$	I_{CCH}		30	40	mA
			I_{CCL}		32	40	mA

NOTES:

- For conditions shown as MIN or MAX, use the appropriate value specified under recommended operating conditions for the applicable type.
- All typical values are at $V_{CC} = 5V$, $T_{amb} = 25^\circ\text{C}$.
- Not more than one output should be shorted at a time. For testing I_{OS} , the use of high-speed test apparatus and/or sample-and-hold techniques are preferable in order to minimize internal heating and more accurately reflect operational values. Otherwise, prolonged shorting of a High output may raise the chip temperature well above normal and thereby cause invalid readings in other parameter tests. In any sequence of parameter tests, I_{OS} tests should be performed last.

AC ELECTRICAL CHARACTERISTICS

SYMBOL	PARAMETER	TEST CONDITION	LIMITS						UNIT
			$T_{amb} = +25^\circ\text{C}$ $V_{CC} = +5.0V$ $C_L = 50pF$ $R_L = 500\Omega$			$T_{amb} = 0^\circ\text{C to } +70^\circ\text{C}$ $V_{CC} = +5.0V \pm 10\%$ $C_L = 50pF$ $R_L = 500\Omega$			
			MIN	TYP	MAX	MIN	MAX		
f_{MAX}	Maximum clock frequency	Waveform NO TAG	110	115		105		ns	
t_{PLH} t_{PHL}	Propagation delay \overline{CP} to Q_n	Waveform NO TAG	4.0 4.5	5.5 6.5	7.5 8.5	4.0 4.5	9.0 9.5	ns	

Quad 2-input multiplexer with storage

74F298

AC SETUP REQUIREMENTS

SYMBOL	PARAMETER	TEST CONDITION	LIMITS				UNIT	
			T _{amb} = +25°C V _{CC} = +5.0V C _L = 50pF R _L = 500Ω			T _{amb} = 0°C to +70°C V _{CC} = +5.0V ± 10% C _L = 50pF R _L = 500Ω		
			MIN	TYP	MAX	MIN		MAX
t _s (H) t _s (L)	Setup time, High or Low I _{0n} , I _{1n} to \overline{CP}	Waveform NO TAG	2.0 2.0			2.0 2.0	ns	
t _h (H) t _h (L)	Hold time, High or Low I _{0n} , I _{1n} to \overline{CP}	Waveform NO TAG	1.0 1.0			1.0 1.0	ns	
t _s (H) t _s (L)	Setup time, High or Low S to \overline{CP}	Waveform NO TAG	6.0 5.0			7.0 6.0	ns	
t _h (H) t _h (L)	Hold time, High or Low S to \overline{CP}	Waveform NO TAG	0 0			0 0	ns	
t _w (H) t _w (L)	\overline{CP} Pulse width, High or Low	Waveform NO TAG	5.0 5.0			5.0 7.0	ns	

AC WAVEFORMS

For all waveforms, V_M = 1.5V.

The shaded areas indicate when the input is permitted to change for predictable output performance.

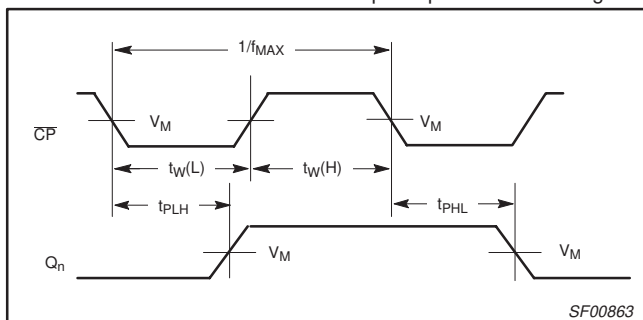

Waveform 1. Clock Input to Output, Clock Pulse Width, and Maximum Clock Frequency

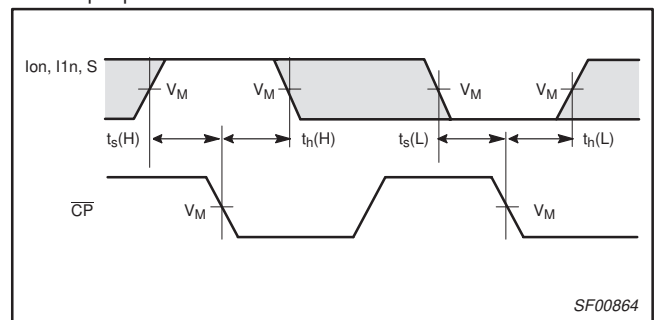

Waveform 2. Data Setup and Hold Times

TEST CIRCUIT AND WAVEFORMS

Test Circuit for Totem-Pole Outputs

Input Pulse Definition

DEFINITIONS:
 R_L = Load resistor;
 see AC ELECTRICAL CHARACTERISTICS for value.
 C_L = Load capacitance includes jig and probe capacitance;
 see AC ELECTRICAL CHARACTERISTICS for value.
 R_T = Termination resistance should be equal to Z_{OUT} of
 pulse generators.

family	INPUT PULSE REQUIREMENTS					
	amplitude	V _M	rep. rate	t _w	t _{TLH} (tr)	t _{THL}
74F	3.0V	1.5V	1MHz	500ns	2.5ns	2.5ns

SF00006

Quad 2-input multiplexer with storage

74F298

DIP16: plastic dual in-line package; 16 leads (300 mil)

SOT38-4

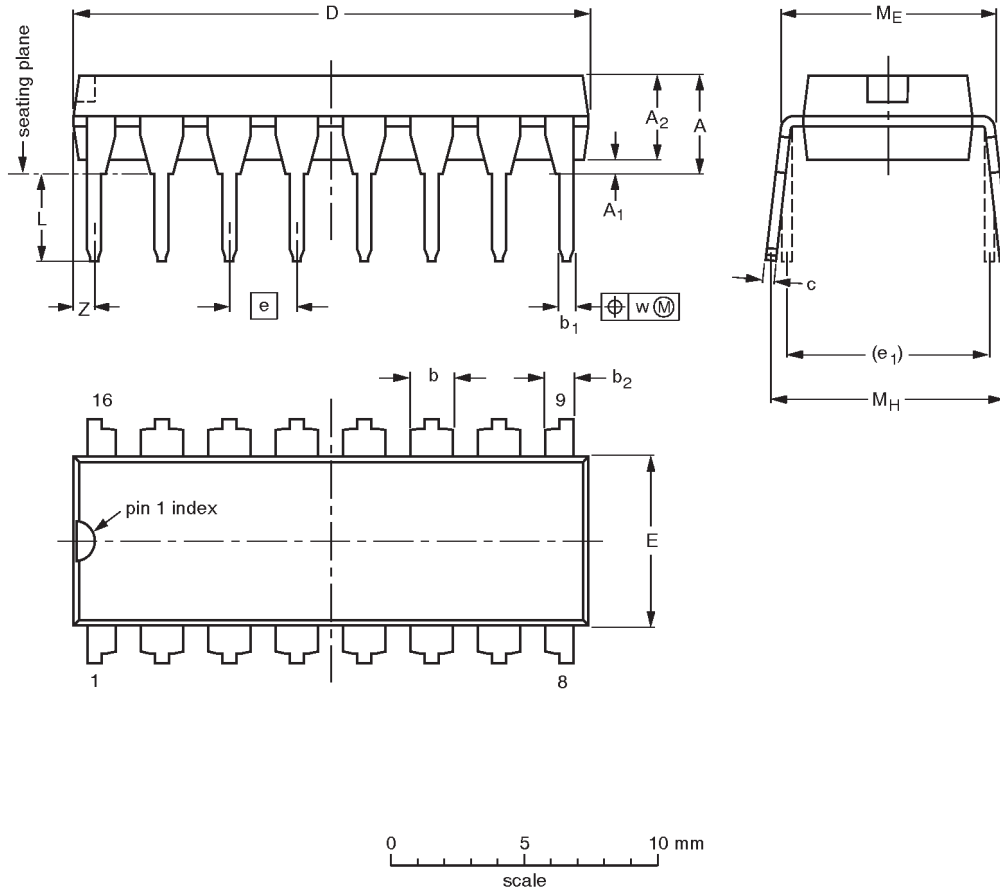

DIMENSIONS (inch dimensions are derived from the original mm dimensions)

UNIT	A max.	A ₁ min.	A ₂ max.	b	b ₁	b ₂	c	D ⁽¹⁾	E ⁽¹⁾	e	e ₁	L	M _E	M _H	w	Z ⁽¹⁾ max.
mm	4.2	0.51	3.2	1.73 1.30	0.53 0.38	1.25 0.85	0.36 0.23	19.50 18.55	6.48 6.20	2.54	7.62	3.60 3.05	8.25 7.80	10.0 8.3	0.254	0.76
inches	0.17	0.020	0.13	0.068 0.051	0.021 0.015	0.049 0.033	0.014 0.009	0.77 0.73	0.26 0.24	0.10	0.30	0.14 0.12	0.32 0.31	0.39 0.33	0.01	0.030

Note

1. Plastic or metal protrusions of 0.25 mm maximum per side are not included.

OUTLINE VERSION	REFERENCES				EUROPEAN PROJECTION	ISSUE DATE
	IEC	JEDEC	EIAJ			
SOT38-4						-92-11-17 95-01-14

Quad 2-input multiplexer with storage

74F298

SO16: plastic small outline package; 16 leads; body width 3.9 mm

SOT109-1

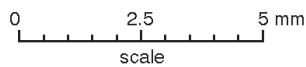
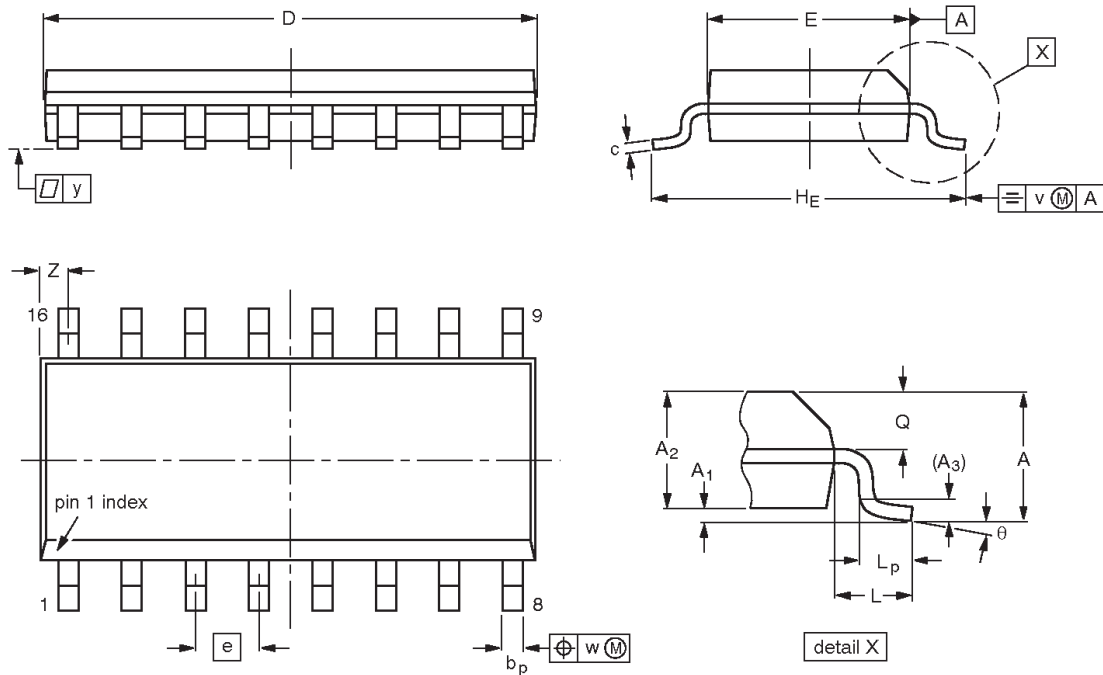

DIMENSIONS (inch dimensions are derived from the original mm dimensions)

UNIT	A max.	A ₁	A ₂	A ₃	b _p	c	D ⁽¹⁾	E ⁽¹⁾	e	H _E	L	L _p	Q	v	w	y	Z ⁽¹⁾	θ
mm	1.75 0.10	0.25 1.25	1.45 0.049	0.25	0.49 0.36	0.25 0.19	10.0 9.8	4.0 3.8	1.27	6.2 5.8	1.05	1.0 0.4	0.7 0.6	0.25	0.25	0.1	0.7 0.3	8° 0°
inches	0.069 0.004	0.010 0.049	0.057 0.014	0.01	0.019 0.014	0.0100 0.0075	0.39 0.38	0.16 0.15	0.050	0.244 0.228	0.041	0.039 0.016	0.028 0.020	0.01	0.01	0.004	0.028 0.012	

Note

1. Plastic or metal protrusions of 0.15 mm maximum per side are not included.

OUTLINE VERSION	REFERENCES				EUROPEAN PROJECTION	ISSUE DATE
	IEC	JEDEC	EIAJ			
SOT109-1	076E07S	MS-012AC				95-01-23 97-05-22

Quad 2-input multiplexer with storage

74F298

Data sheet status

Data sheet status	Product status	Definition [1]
Objective specification	Development	This data sheet contains the design target or goal specifications for product development. Specification may change in any manner without notice.
Preliminary specification	Qualification	This data sheet contains preliminary data, and supplementary data will be published at a later date. Philips Semiconductors reserves the right to make changes at any time without notice in order to improve design and supply the best possible product.
Product specification	Production	This data sheet contains final specifications. Philips Semiconductors reserves the right to make changes at any time without notice in order to improve design and supply the best possible product.

[1] Please consult the most recently issued datasheet before initiating or completing a design.

Definitions

Short-form specification — The data in a short-form specification is extracted from a full data sheet with the same type number and title. For detailed information see the relevant data sheet or data handbook.

Limiting values definition — Limiting values given are in accordance with the Absolute Maximum Rating System (IEC 134). Stress above one or more of the limiting values may cause permanent damage to the device. These are stress ratings only and operation of the device at these or at any other conditions above those given in the Characteristics sections of the specification is not implied. Exposure to limiting values for extended periods may affect device reliability.

Application information — Applications that are described herein for any of these products are for illustrative purposes only. Philips Semiconductors make no representation or warranty that such applications will be suitable for the specified use without further testing or modification.

Disclaimers

Life support — These products are not designed for use in life support appliances, devices or systems where malfunction of these products can reasonably be expected to result in personal injury. Philips Semiconductors customers using or selling these products for use in such applications do so at their own risk and agree to fully indemnify Philips Semiconductors for any damages resulting from such application.

Right to make changes — Philips Semiconductors reserves the right to make changes, without notice, in the products, including circuits, standard cells, and/or software, described or contained herein in order to improve design and/or performance. Philips Semiconductors assumes no responsibility or liability for the use of any of these products, conveys no license or title under any patent, copyright, or mask work right to these products, and makes no representations or warranties that these products are free from patent, copyright, or mask work right infringement, unless otherwise specified.

Philips Semiconductors
811 East Arques Avenue
P.O. Box 3409
Sunnyvale, California 94088-3409
Telephone 800-234-7381

© Copyright Philips Electronics North America Corporation 1998
All rights reserved. Printed in U.S.A.

print code

Date of release: 10-98

Document order number:

9397-750-05116

Let's make things better.