



Chipsmall Limited consists of a professional team with an average of over 10 year of expertise in the distribution of electronic components. Based in Hongkong, we have already established firm and mutual-benefit business relationships with customers from,Europe,America and south Asia,supplying obsolete and hard-to-find components to meet their specific needs.

With the principle of "Quality Parts,Customers Priority,Honest Operation,and Considerate Service",our business mainly focus on the distribution of electronic components. Line cards we deal with include Microchip,ALPS,ROHM,Xilinx,Pulse,ON,Everlight and Freescale. Main products comprise IC,Modules,Potentiometer,IC Socket,Relay,Connector.Our parts cover such applications as commercial,industrial, and automotives areas.

We are looking forward to setting up business relationship with you and hope to provide you with the best service and solution. Let us make a better world for our industry!



Contact us

Tel: +86-755-8981 8866 Fax: +86-755-8427 6832

Email & Skype: info@chipsmall.com Web: www.chipsmall.com

Address: A1208, Overseas Decoration Building, #122 Zhenhua RD., Futian, Shenzhen, China



NAM series

NAM -10 -000 -□

① ② ③ ④

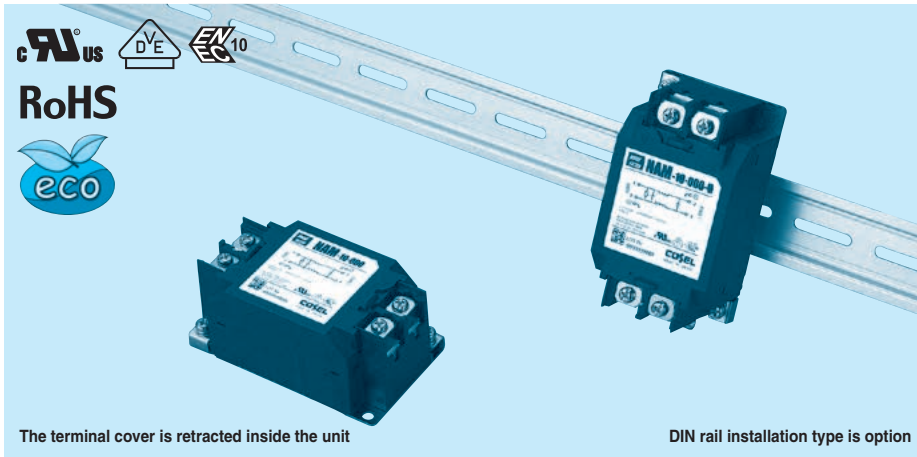

- ① Model Name
- ② Rated Current
- ③ Line to ground capacitor code: See table 1.1.

table 1.1 Line to ground capacitor code

| Code | Leakage Current (Input 125/250V 60Hz) | Line to ground capacitor (nominal value) |
|------|---------------------------------------|--|
| 000 | 5 μ A / 10 μ A max | Not Provided |
| 101 | 12.5 μ A / 25 μ A max | 100pF |
| 221 | 25 μ A / 50 μ A max | 220pF |
| 331 | 37.5 μ A / 75 μ A max | 330pF |
| 471 | 50 μ A / 100 μ A max | 470pF |

* When the line to ground capacitor code is different, the attenuation characteristic is different.

- ④ Options
- D: DIN rail installation type

* The dimensions change when the option is set. Refer to External view.

Features of NAM series

Low leakage current type

- Single Phase 250 VAC
- Push down type terminal block

Specifications

| No. | Items | NAM-04-000 | NAM-06-000 | NAM-10-000 | NAM-16-000 | NAM-20-000 | NAM-30-000 |
|-----|--|--|------------|------------|------------|------------|------------|
| 1 | Rated Voltage[V] | AC 1 ϕ 250 / DC250 | | | | | |
| 2 | Rated Current[A] | 4 | 6 | 10 | 16 | 20 | 30 |
| 3 | Test Voltage (Terminal-Mounting Plate) | 2,500 VAC (Cutoff Current = 20mA), 1minute at room temperature and humidity | | | | | |
| 4 | Isolation Resistance (Terminal-Mounting Plate) | 500 VDC 100M Ω min at room temperature and humidity | | | | | |
| 5 | Leakage current 125/250V 60Hz | 5 μ A/10 μ A max | | | | | |
| 6 | Voltage drop | 1.0V max | | | | | |
| 7 | Safety agency approval temperatures | -25 to +85 $^{\circ}$ C (Refer to Derating Curve) | | | | | |
| 8 | Operating temperature | -40 to +85 $^{\circ}$ C (Refer to Derating Curve) | | | | | |
| 9 | Operating humidity | 20 to 95%RH (Non condensing) | | | | | |
| 10 | Storage temperature/humidity | -40 to +85 $^{\circ}$ C/20 to 95%RH (Non condensing) | | | | | |
| 11 | Vibration | 10 to 55Hz, 19.6m/s 2 (2G), 3min. Period, 1hour each X, Y and Z axis | | | | | |
| 12 | Impact | 196.1m/s 2 (20G), 11ms Once each X, Y and Z axis | | | | | |
| 13 | Safety agency approvals | UL1283, CSA C22.2 No.8 (C-UL), DIN EN60939 VDE0565 Teil3-1, ENEC (At only AC input) | | | | | |
| 14 | Case size (without projection) /Weight | 53 X 41 X 92 mm [2.09 X 1.61 X 3.62 inches] (W X H X D) /300g max (Option : -D refer to external view) | | | | | |

Circuit Diagram

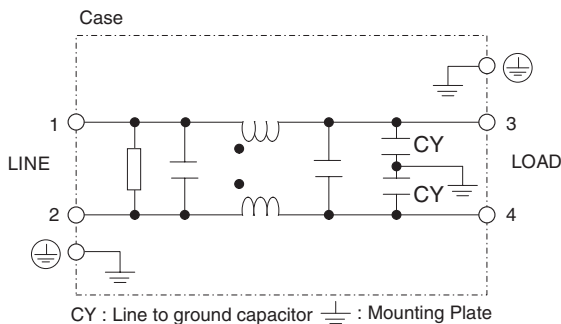

Derating Curve

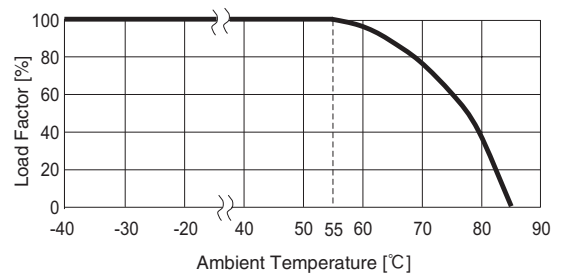

External view

As this product is adopted push-down type terminal block, this appearance is as follows.

- ① The terminal cover is retracted inside the unit.
- ② The screws for connecting the terminals are held in the up right position.

Standard Type

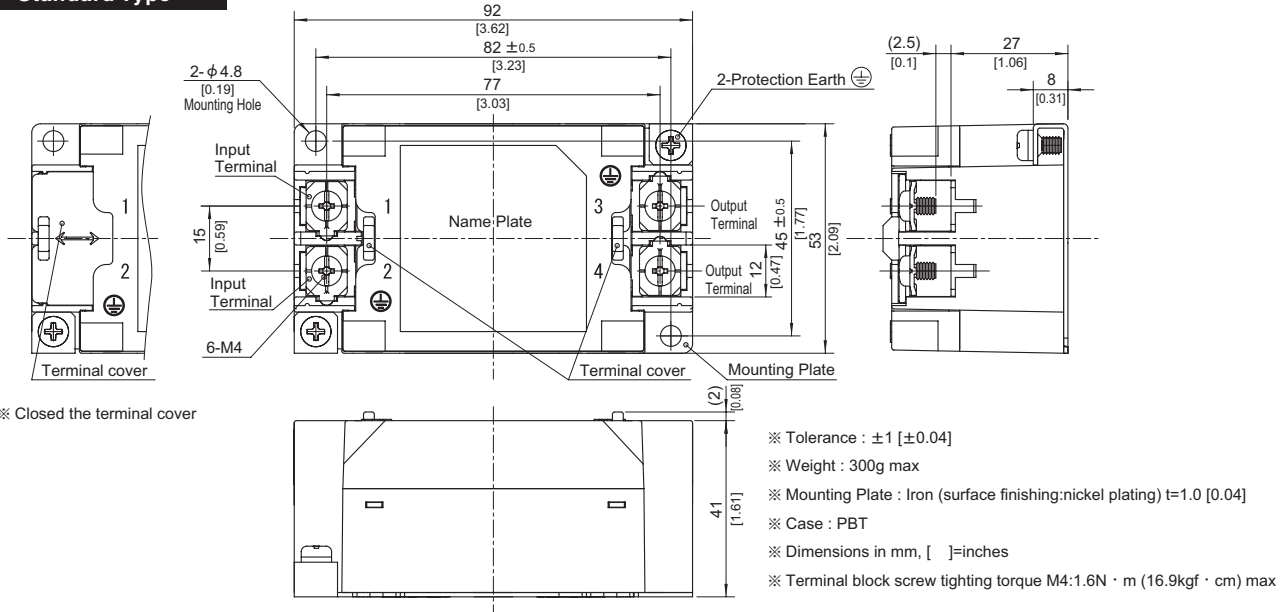

DIN rail installation Type

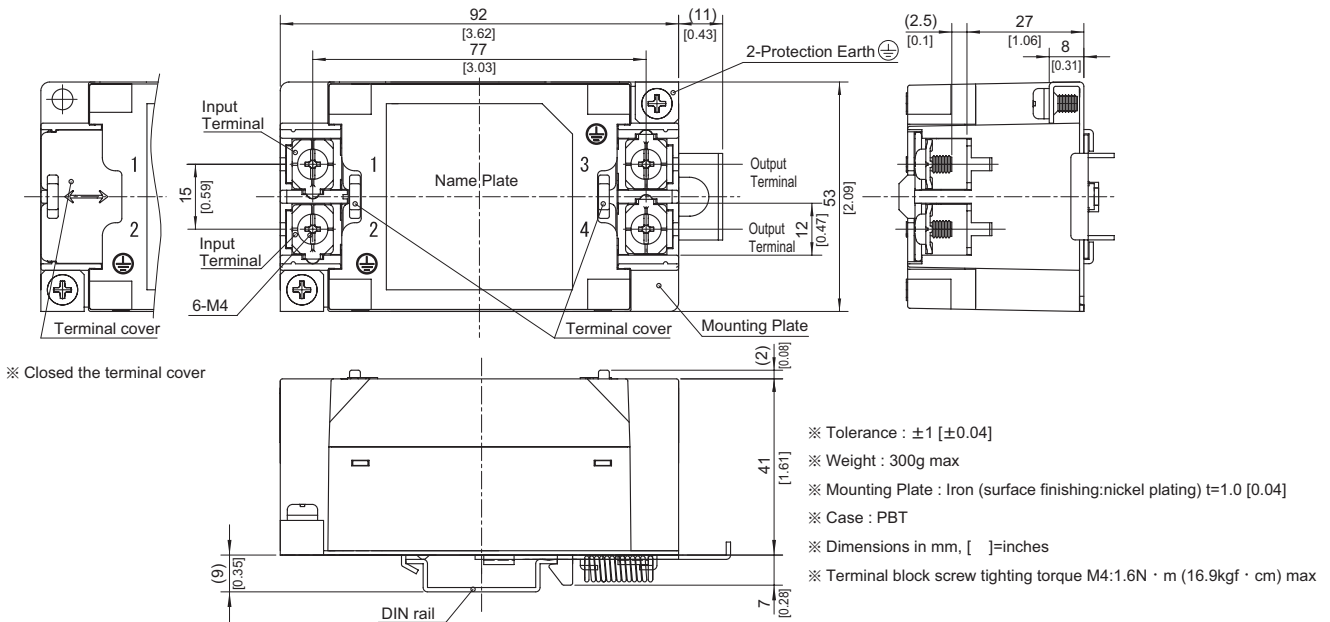

■Note when installing the EMI/EMC Filter on a DIN rail.

When the EMI/EMC Filter is grounded through the DIN rail, the proper noise attenuation may not be achieved.

Be sure to connect the protection earth (PE) of the EMI/EMC Filter body to the earth. It can connect the ground to either one only.

