



Chipsmall Limited consists of a professional team with an average of over 10 year of expertise in the distribution of electronic components. Based in Hongkong, we have already established firm and mutual-benefit business relationships with customers from,Europe,America and south Asia,supplying obsolete and hard-to-find components to meet their specific needs.

With the principle of “Quality Parts,Customers Priority,Honest Operation,and Considerate Service”,our business mainly focus on the distribution of electronic components. Line cards we deal with include Microchip,ALPS,ROHM,Xilinx,Pulse,ON,Everlight and Freescale. Main products comprise IC,Modules,Potentiometer,IC Socket,Relay,Connector.Our parts cover such applications as commercial,industrial, and automotives areas.

We are looking forward to setting up business relationship with you and hope to provide you with the best service and solution. Let us make a better world for our industry!



Contact us

Tel: +86-755-8981 8866 Fax: +86-755-8427 6832

Email & Skype: info@chipsmall.com Web: www.chipsmall.com

Address: A1208, Overseas Decoration Building, #122 Zhenhua RD., Futian, Shenzhen, China



LoRho SMD PTC for Charging Cable Protection

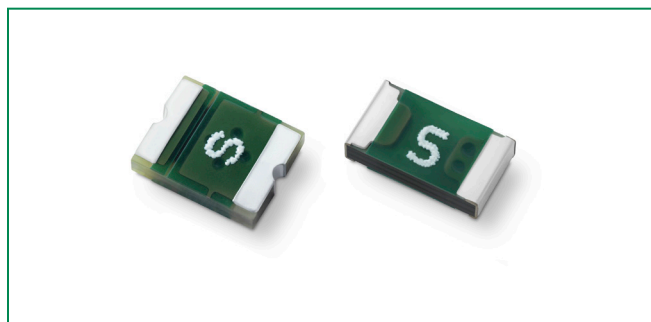

Description

The Littelfuse LoRho SMD PTC for Charging Cables provides protection from heat generated due to faults within the connector such as USB-C, microUSB, and many others.

As connectors get smaller, their pin-to-pin spacings are shrinking which increases the opportunity for debris such as dust, dirt, or water to collect causing a fault. These faults can generate a tremendous amount of heat which will damage charging cables, the devices they charge, or people using them.

Agency Approvals

AGENCY	AGENCY FILE NUMBER	AMPERE RANGE
	E74889	4.5A
	Pending	Pending

Features

- SMD compatible with reflow soldering process
- Available in small 1206 and 1210 sizes
- Up to 12Vdc and 4.5A I_{hold}
- Ultra low internal resistance
- Reset automatically
- Halogen-free, lead-free and RoHS compliant

Applications

- Over temperature (OT) protection for USB connectors and cables including:
 - USB Type-C
 - USB Micro-B
 - USB-A
- Fast charging standards and protocols including:
 - USB Power Delivery (PD) †
 - Qualcomm Quick Charge (QC) †
 - Mediatek Pump Express (PE) †
 - Samsung Adaptive Fast Charging (AFC) †
 - Huawei/HiSilicon Fast Charging Protocol (FCP) †

† These charging protocols are the property of their respective owners.

Electrical Characteristics

Part Number	Marking	I_{hold}^1 (A)	V_{max}^2 (Vdc)	Thermal Cut Off (TCO) - °C @ 2A		Thermal Cut Off (TCO) - °C @ 3A		P_d^3 typ. (W)	Resistance		Agency Approvals	
				Min	Max	Min	Max		R_{min}^4 (Ω)	R_{1max}^5 (Ω)		
nanoSMD350LR-C	P	3.50	12	65	85	50	75	1.0	0.004	0.018	--	--
nanoSMD400LR-C	S	4.00	12	70	100	65	90	1.0	0.004	0.010	--	--
microSMD450LR-C	S	4.50	12	90	110	80	100	1.0	0.002	0.0085	X	X

Notes:

- I_{hold} = Hold current: maximum current device will pass without tripping in 20°C still air
- V_{max} = Maximum voltage device can withstand without damage at rated current (I_{max})
- P_d = Power dissipated from device when in the tripped state at 20°C still air
- R_{min} = Minimum resistance of device in initial (un-soldered) state
- R_{1max} = Maximum resistance of device at 20°C measured one hour after tripping or reflow Soldering of 260°C for 20 seconds

(Values specified were determined using PCBs with 0.115in x 1.0in ounce copper traces)

Caution: Operation beyond the specified rating may result in damage and possible arcing and flame

TCO and Pd Testing Method:

Thermal Cut-Off Test-

- Put the device into the thermostatic chamber controlled at room temperature or 25°C.
- Apply the specified current to the device, and increase the chamber temperature at the rate of 2°C per minute.
- Measure the device ambient temperature when the applied current has reduced to less than 20% of initial value.

Power Dissipation-

- Conduct thermal cut-off test at rated current/voltage.
- After device trip, decrease the chamber temperature with keeping trip state.
- Measure the tripped-state power dissipation when the device ambient temperature has reduced to 30°C or less.

Temperature Derating

Part Number	Ambient Operating Temperature				
	-20°C	0°C	20°C	60°C	85°C
nanoSMD350LR-C	4.80	4.00	3.50	1.90	1.30
nanoSMD400LR-C	5.20	4.60	4.00	2.82	2.10
microSMD450LR-C	6.20	5.50	4.50	3.30	2.30

Note: The temperature derating data is for reference only. Please contact Littelfuse technical support for detail temperature derating information.

Temperature Derating Curve

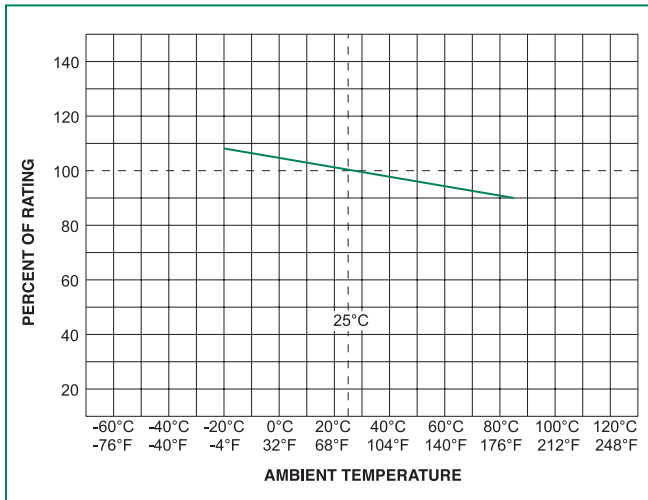

Environmental Specifications

Operating Temperature	-20°C to +85°C
Maximum Device Surface Temperature in Tripped State	125°C
Passive Aging	+85°C, 1000 hours -/ +10% typical resistance change
Humidity Aging	+85°C, 85% R.H., 100 hours -/ +15% typical resistance change
Thermal Shock	MIL-STD-202, Method 215 No change
Vibration	MIL-STD-883, Method 2007, Condition A No change
Moisture Sensitivity Level	Level 2a, J-STD-020

Physical Specifications

Terminal Materials	Solder-Plated Copper (Solder Material: Matte Tin (Sn))
Lead Solderability	Meets EIA Specification RS186-9E, ANSI/J-STD-002, Category 3

Soldering Parameters

Profile Feature		Pb – Free assembly
Pre Heat	- Temperature Min ($T_{s(min)}$)	150°C
	- Temperature Max ($T_{s(max)}$)	200°C
	- Time (min to max) (t_s)	60 – 120 seconds
Average ramp up rate (Liquidus Temp (T_L) to peak)		3°C/second max
$T_{s(max)}$ to T_L - Ramp-up Rate		3°C/second max
Reflow	- Temperature (T_L) (Liquidus)	217°C
	- Temperature (t_L)	60 – 150 seconds
Peak Temperature (T_p)		260°C
Time within 5°C of actual peak Temperature (t_p)		30 seconds max
Ramp-down Rate		2°C/second max
Time 25°C to peak Temperature (T_p)		8 minutes max

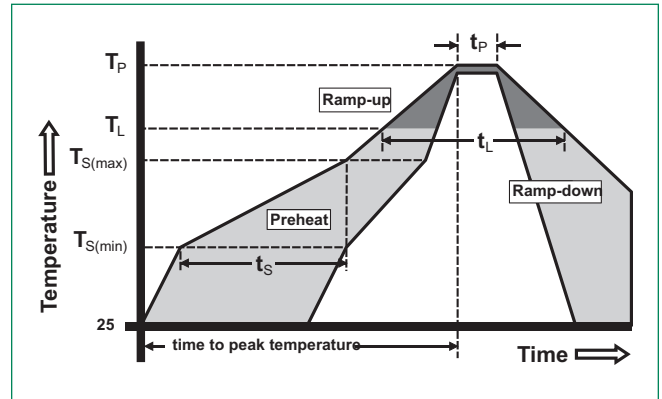

Notes:

- All temperature refer to topside of the package, measured on the package body surface.
- If reflow temperature exceeds the recommended profile, devices may not meet the performance requirements.
- Recommended reflow methods: IR, vapor phase oven, hot air oven, N₂ environment for lead.
- Recommended maximum paste thickness is 0.25 mm (0.010 inch).
- Devices can be cleaned using standard industry methods and solvents.
- Devices can be reworked using the standard industry practices.

Dimensions

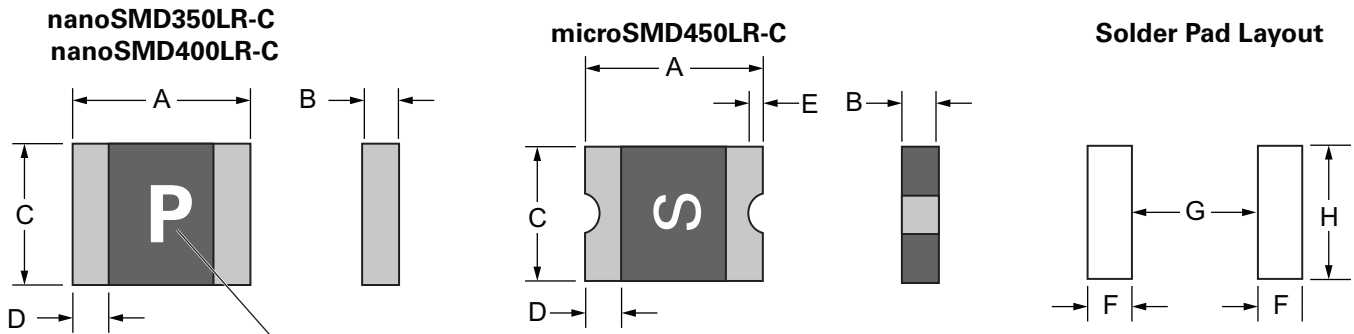

Marking code varies by device.
See Electrical Characteristics table.

Part Number	Device Dimension																Solder Pad									
	A				B				C				D				E		F		G		H			
	inch		mm		inch		mm		inch		mm		inch		mm		inch		mm		inch		mm			
	Min	Max	Min	Max	Min	Max	Min	Max	Min	Max	Min	Max	Min	Max	Min	Max	Min	Max	Min	Max	Min	Max	Min	Max		
nanoSMD350LR-C	0.12	0.13	3.00	3.43	0.02	0.03	0.60	0.80	0.05	0.07	1.37	1.85	0.01	0.03	0.25	0.75	-	-	-	-	0.04	1.10	0.08	2.00	0.07	1.75
nanoSMD400LR-C	0.12	0.13	3.00	3.43	0.02	0.03	0.60	0.80	0.05	0.07	1.37	1.85	0.01	0.03	0.25	0.75	-	-	-	-	0.04	1.10	0.08	2.00	0.07	1.75
microSMD450LR-C	0.12	0.13	3.00	3.43	0.02	0.03	0.60	0.80	0.09	0.11	2.35	2.80	0.01	0.03	0.25	0.75	0.003	-	0.076	-	0.04	1.00	0.08	2.00	0.10	2.65

Packaging

Part Number	Ordering	I_{HOLD} (A)	I_{HOLD} Code	Packaging Option	Quantity
nanoSMD350LR-C	RF4610-000	3.50	350	Tape and Reel	15,000
nanoSMD400LR-C	RF4611-000	4.00	400		15,000
microSMD450LR-C	RF2515-000	4.50	450		15,000

Part Numbering System

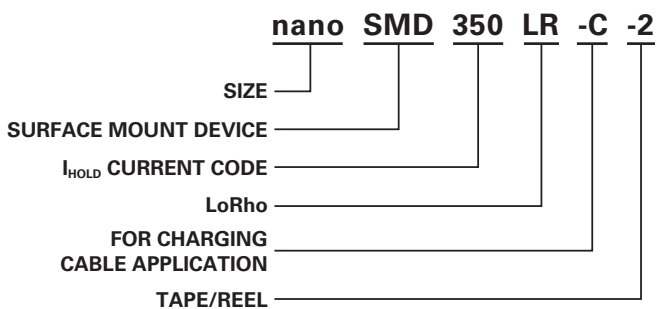

Installation and Handling Guidelines

- Operation of these devices beyond the stated maximum ratings could result in damage to the devices and lead to electrical arcing and/or fire.
- These devices are intended to protect against the effects of temporary over-current or over-temperature conditions and are not intended to perform as protective devices where such conditions are expected to be repetitive or prolonged in duration.
- Exposure to silicon-based oils, solvents, electrolytes, acids, and similar materials can adversely affect the performance of these PPTC devices.
- These devices undergo thermal expansion under fault conditions, and thus shall be provided with adequate space and be protected against mechanical stresses.
- Circuits with inductance may generate a voltage ($L di/dt$) above the rated voltage of the PPTC device.
- Hand-soldering of PTC devices on boards is generally not recommended. Users shall define and verify this process if needed.
- Consult Littelfuse when the device is to be applied with thermal processes other than reflow process on the circuit board, such as molding, encapsulation. User should evaluate molding materials used in the charging cable applications to ensure there are no adverse effect on the PTC devices.

Tape and Reel Specifications

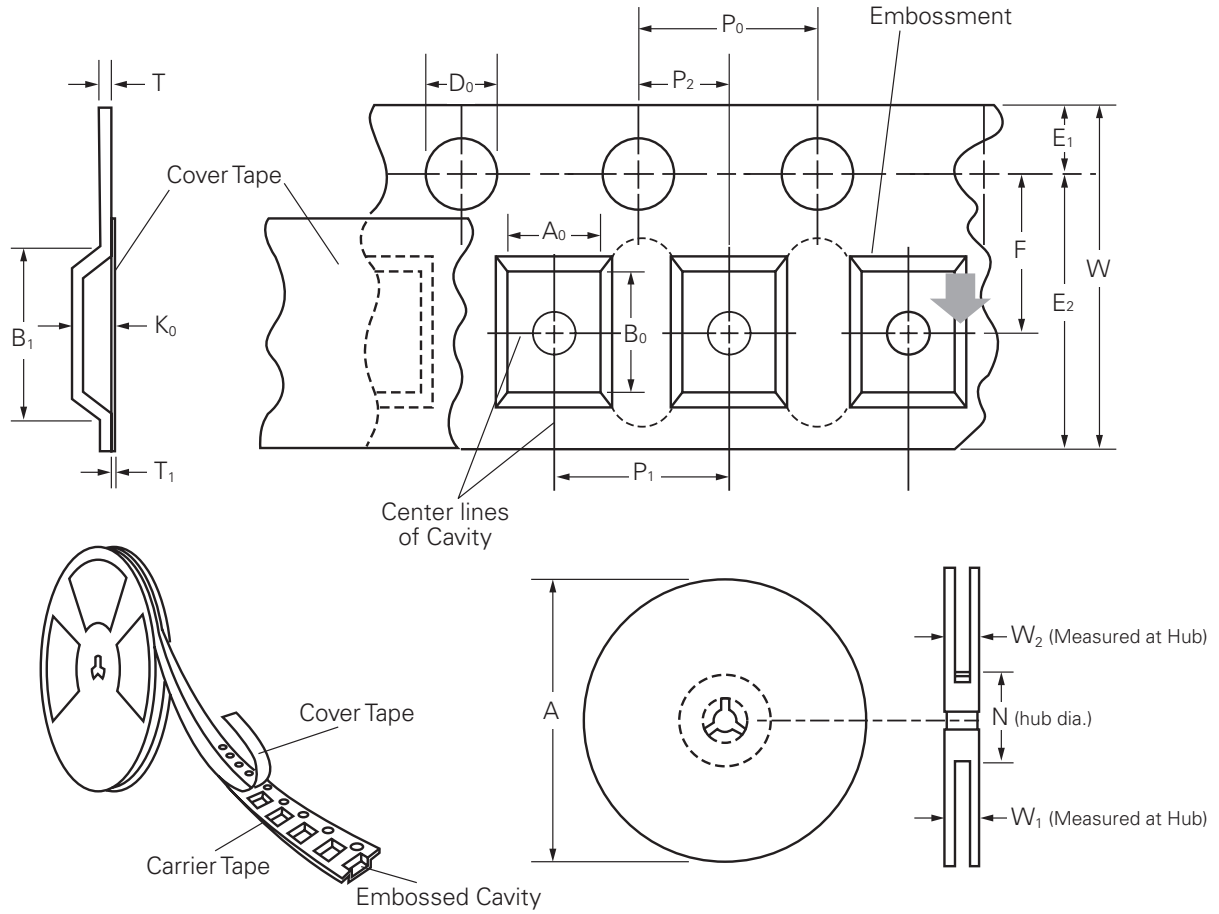

Standard Pack Quantity: 3,000 pcs
Minimum Order Quantity: 15,000 pcs

	nanoSMD350LR-C nanoSMD400LR-C	microSMD450LR-C
W	8.0 ± 0.30	8.0 ± 0.30
P ₀	4.0 ± 0.10	4.0 ± 0.10
P ₁	4.0 ± 0.10	4.0 ± 0.10
P ₂	2.0 ± 0.05	2.0 ± 0.05
A ₀	1.95 ± 0.10	2.9 ± 0.10
B ₀	3.50 + 0.1/-0.08	3.55 ± 0.10
B ₁ max.	4.35	4.35
D ₀	1.55 ± 0.05	1.55 ± 0.05
F	3.50 ± 0.05	3.50 ± 0.05
E ₁	1.75 ± 0.10	1.75 ± 0.10
E ₂ min.	6.25	6.25
T max.	0.3	0.3
T ₁ max.	0.1	0.1
K ₀	0.89 ± 0.10	1.27 ± 0.10
A max.	179	179
N min.	53.5	53.5
W ₁	9.5 ± 0.5	9.5 ± 0.5
W ₂ max.	15	15