



Chipsmall Limited consists of a professional team with an average of over 10 year of expertise in the distribution of electronic components. Based in Hongkong, we have already established firm and mutual-benefit business relationships with customers from,Europe,America and south Asia,supplying obsolete and hard-to-find components to meet their specific needs.

With the principle of “Quality Parts,Customers Priority,Honest Operation,and Considerate Service”,our business mainly focus on the distribution of electronic components. Line cards we deal with include Microchip,ALPS,ROHM,Xilinx,Pulse,ON,Everlight and Freescale. Main products comprise IC,Modules,Potentiometer,IC Socket,Relay,Connector.Our parts cover such applications as commercial,industrial, and automotives areas.

We are looking forward to setting up business relationship with you and hope to provide you with the best service and solution. Let us make a better world for our industry!



Contact us

Tel: +86-755-8981 8866 Fax: +86-755-8427 6832

Email & Skype: info@chipsmall.com Web: www.chipsmall.com

Address: A1208, Overseas Decoration Building, #122 Zhenhua RD., Futian, Shenzhen, China



NAU82011VG Evaluation Board User Manual

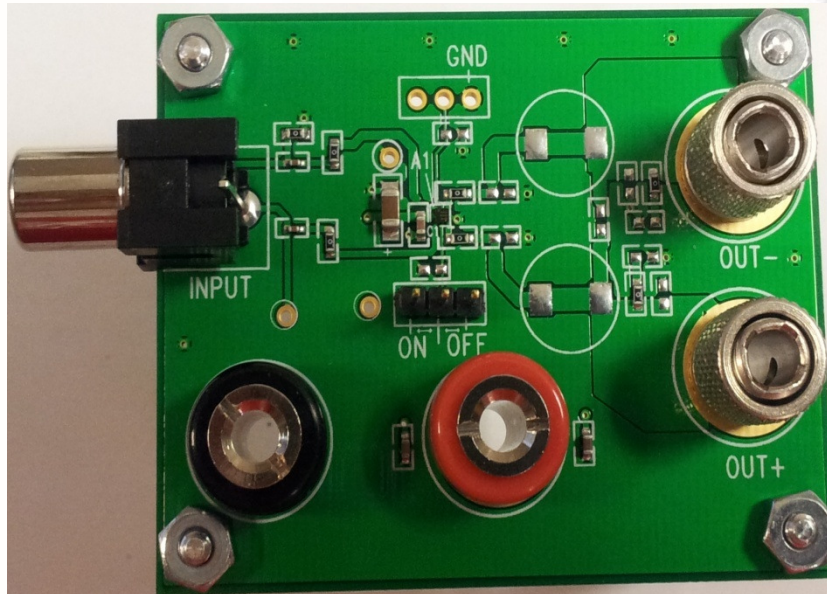

1. General Description

The NAU82011VG is a mono high efficiency filter-free Class-D audio amplifier with variable gain, which is capable of driving a 4Ω load with up to 3.1 W output power. This device provides chip enable pin with extremely low standby current and fast start-up time. The ability to configure with either single-ended or differential inputs is included. The NAU82011VG has advanced features like 91% efficiency and low quiescent current. The NAU82011VG is ideal for the portable applications of battery drive.

2. EVB Set Up

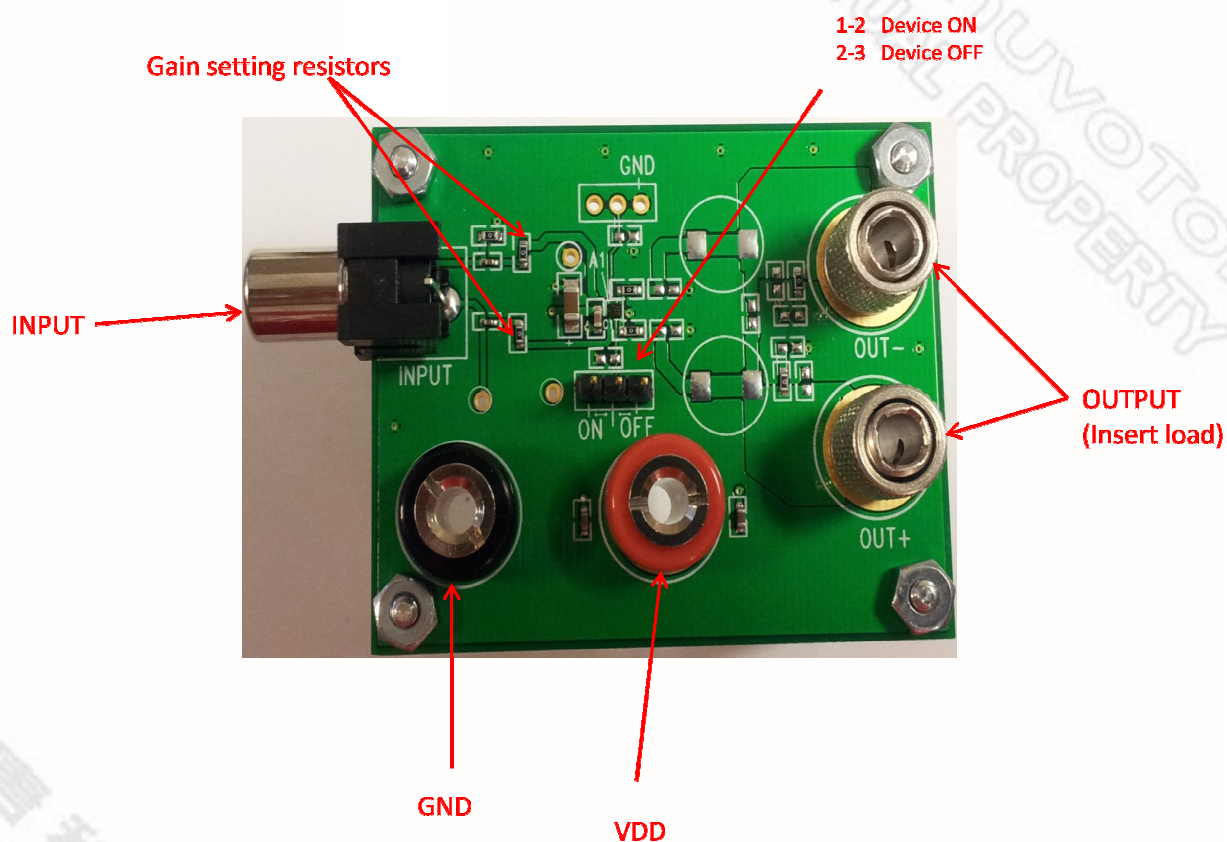

Power Connection

An external DC Voltage supply with a compliance of at least 2 Amperes should be connected to VDD & GND.

Gain Setting

NAU82011VG is a variable gain amplifier. The gain can be varied by varying the external input resistors(R1). The device has an on chip feedback resistor of 300kΩ. The gain is expressed as follows

$$Gain = \frac{300 \text{ k}\Omega}{R1 \text{ k}\Omega} \left(\frac{V}{V} \right) \qquad Gain \text{ (dB)} = 20 \log \frac{300 \text{ k}\Omega}{R1 \text{ k}\Omega}$$

The Evaluation board comes with 150kΩ resistors or a Gain of 6dB.

Input Connection

The default input configuration is single ended mode. If differential configuration is desired then, the 0 ohm resistor R7 needs to be removed. If Audio Precision Analyzer is used as input source, Unbalanced inputs are to be selected for single ended operation or Balanced inputs for differential mode.

Output Connection

An 8 ohm 68uH load should be connected on the output channel (J3- J2). Connect the outputs to the inputs of the Audio Precision Analyzer (Balanced) via the AP0025 Aux Filter.

Power Up

For optimum performance the board should be power up with in switch closed state. Once the power is applied switch must be released to power up the board. Then, the input signal can be applied.

Important note:

When using a power supply, it is recommended to use a 330μF capacitor across the power pins to suppress any supply glitches, as a safety measure. When a battery is used, the capacitor is not required. In normal applications too, the capacitor is not required.

3. Schematic:

