



Chipsmall Limited consists of a professional team with an average of over 10 year of expertise in the distribution of electronic components. Based in Hongkong, we have already established firm and mutual-benefit business relationships with customers from,Europe,America and south Asia,supplying obsolete and hard-to-find components to meet their specific needs.

With the principle of “Quality Parts,Customers Priority,Honest Operation,and Considerate Service”,our business mainly focus on the distribution of electronic components. Line cards we deal with include Microchip,ALPS,ROHM,Xilinx,Pulse,ON,Everlight and Freescale. Main products comprise IC,Modules,Potentiometer,IC Socket,Relay,Connector.Our parts cover such applications as commercial,industrial, and automotives areas.

We are looking forward to setting up business relationship with you and hope to provide you with the best service and solution. Let us make a better world for our industry!



Contact us

Tel: +86-755-8981 8866 Fax: +86-755-8427 6832

Email & Skype: info@chipsmall.com Web: www.chipsmall.com

Address: A1208, Overseas Decoration Building, #122 Zhenhua RD., Futian, Shenzhen, China



3.2W Mono Filter-Free Class-D Audio Amplifier

1 Description

The NAU82039 is a mono high efficiency filter-free Class-D audio amplifier with 12dB of fixed gain, which is capable of driving a 4Ω load with up to 3.2W output power. This device provides chip enable pin with extremely low standby current and fast start-up time of 4ms.

The NAU82039 is ideal for the portable applications of battery drive, as it has advanced features like 90dB PSRR at 217Hz, 93% efficiency, ultra low quiescent current (i.e. 1.25mA at 3.6V) and superior EMI performance. It has the ability to configure the inputs in either single-ended or differential mode.

NAU82039 is available in Miniature WCSP-9 (1.21mm x 1.23mm in 0.4mm pitch) package.

Key Features

- Low Quiescent Current:
 - 1.25mA at 3.6V
 - 1.8mA at 5V
- Powerful Mono Class-D Amplifier:

<ul style="list-style-type: none"> • 3.2W (4Ω @ 5V, 10% THD+N) • 2.54W (4Ω @ 5V, 1% THD+N) • 1.80W (8Ω @ 5V, 10% THD+N) • 1.42W (8Ω @ 5V, 1% THD+N) 	<ul style="list-style-type: none"> • 1.58 W (4Ω @ 3.6V, 10% THD+N) • 1.27 W (4Ω @ 3.6V, 1% THD+N) • 0.91 W (8Ω @ 3.6V, 10% THD+N) • 0.72 W (8Ω @ 3.6V, 1% THD+N)
---	--
- Low Output Noise: 26 μV_{RMS} (A –Weighted @3.6V)
- 90dB PSRR @217Hz
- Low Current Shutdown Mode
- Click-and Pop Suppression
- 1.21mm x 1.23mm WLCSP (0.4mm Pitch)

Applications

- Smartphones
- Tablet PCs
- Personal Navigation Devices

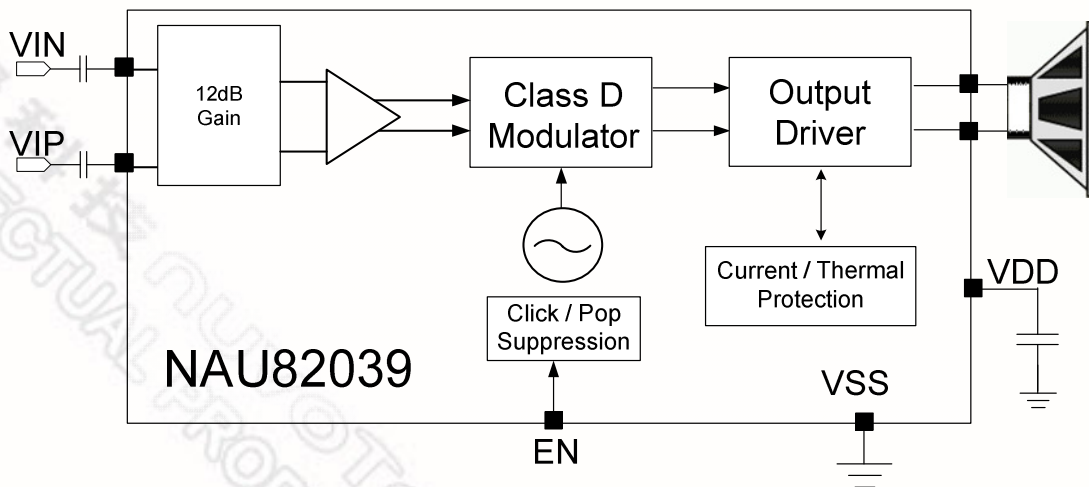

NAU82039 Block Diagram

2 Pin out

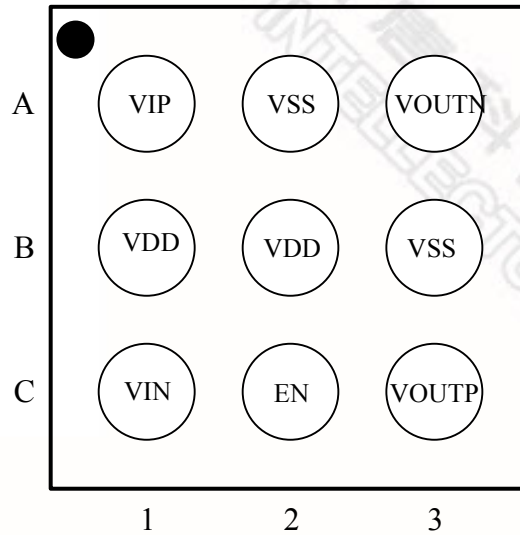

Part Number	Dimension	Package	Package Material
NAU82039VG	1.21mm x 1.23mm	9-bump WCSP (0.4mm pitch)	Pb-Free

3 Pin Descriptions

Pin #	Name	Type	Functionality
A1	VIP	Analog Input	Positive Differential Input
A2	VSS	Supply	High Current Ground
A3	VOUTN	Analog Output	Negative BTL Output
B1	VDD	Supply	Power Supply
B2	VDD	Supply	Power Supply
B3	VSS	Supply	High Current Ground
C1	VIN	Analog Input	Negative Differential Input
C2	EN	Digital Input	Chip Enable (High = Power Up; Low = Power Down)
C3	VOUTP	Analog Output	Positive BTL Output

Table 1 NAU82039 Pin description

Operating Characteristics

Conditions: EN = VDD = 5V, VSS = 0V, Av = 12dB, ZL = ∞, Bandwidth = 20Hz to 22kHz, TA = 25 °C

Parameter	Symbol	Comments/Conditions	Min	Typ	Max	Units	
Power Delivered							
Output Power	P _{out}	Z _L = 4Ω + 33μH	VDD = 5.0V		3.2		W
		THD + N = 10%	VDD = 3.6V		1.58		
		Z _L = 4Ω + 33μH	VDD = 5.0V		2.54		
		THD + N = 1%	VDD = 3.6V		1.27		
		Z _L = 8Ω + 68μH	VDD = 5.0V		1.80		
		THD + N = 10%	VDD = 3.6V		0.91		
		Z _L = 8Ω + 68μH	VDD = 5.0V		1.42		
		THD + N = 1%	VDD = 3.6V		0.72		

Parameter	Symbol	Comments/Conditions	Min	Typ	Max	Units
Chip Enable (EN)						
Voltage Enable High	V _{EN_H}	VDD = 2.5V to 5.5V	1.3			V
Voltage Enable Low	V _{EN_L}	VDD = 2.5V to 5.5V			0.35	V
Input Leakage Current				0.1	2.0	μA
Thermal and Current Protection						
Thermal Shutdown Temperature				150		°C
Thermal Shutdown Hysteresis				20		°C
Limiting Current	I _{LIMIT}			2.0		A
Single Ended Input Resistance	R _{IN}	Av = 12dB		75		kΩ
Resistance (EN pin to GND)	R _{EN}			300		kΩ

Parameter	Symbol	Comments/Conditions	Min	Typ	Max	Units
Normal Operation						
Quiescent Current Consumption	I _{QUI}	VDD = 3.6V		1.20		mA
		VDD = 5V		1.8		mA
Shut Down Current	I _{OFF}	EN = 0		0.1		μA
Oscillator Frequency	f _{OSC}			300		kHz
Efficiency	η	WCSP		93		%
Start Up Time	T _{start}			4		ms
Output Offset Voltage	V _{OS}			±1		mV
Common Mode Rejection Ratio	CMRR	f _{IN} = 217Hz		80		dB
Click-and-Pop Suppression		1Hz Shutdown (Z _L =8Ω)		83		dBV
Power Supply Rejection Ratio	PSRR	DC PSRR		90		dB
		AC PSRR V _{RIPPLE} = 0.2Vpp @217Hz		90		dB
		V _{RIPPLE} = 0.2Vpp@1kHz		84		dB
		V _{RIPPLE} = 0.2Vpp@10kHz		63		dB
Noise Performance		V _{DD} = 3.6V (A-weighted)		26		μV _{RMS}
		V _{DD} = 3.6V (unweighted)		36		μV _{RMS}

Absolute Maximum Ratings

Parameter	Symbol	Condition	Min	Max	Units
DC Power Supply	VDD	VDD-VSS	-0.30	+6.00	V
Analog Input Voltage	AV _{IN}	V _{IN} -VSS	-0.3	VDD+0.3	V
Digital Input Voltage	DV _{IN}	DV _{IN} -VSS	-0.3	VDD+0.3	V
Minimum Load Resistance	R _L			3.2	Ω
Continuous Power Dissipation	P _O	WCSP, T=25°C		530	mW
Continuous Power Dissipation	P _O	WCSP, T=85°C		275	mW
Storage temperature range	T _{st}		-55	+150	°C

CAUTION: Do not operate at or near the maximum ratings listed for extended periods of time. Exposure to such conditions may adversely influence product reliability and result in failures not covered by warranty.

Recommended Operating Conditions

Parameter	Symbol	Condition	Min	Typical	Max	Units
DC Power Supply	VDD	VDD-VSS	2.50	5.00	5.50	V
High-level input voltage(EN pin)	V _{IH}		1.30			V
Low-level input voltage(EN pin)	V _{IL}				0.35	V
Operating Temperature	T _A		-40	+25	+85	°C

The following setup is used to measure the above parameters

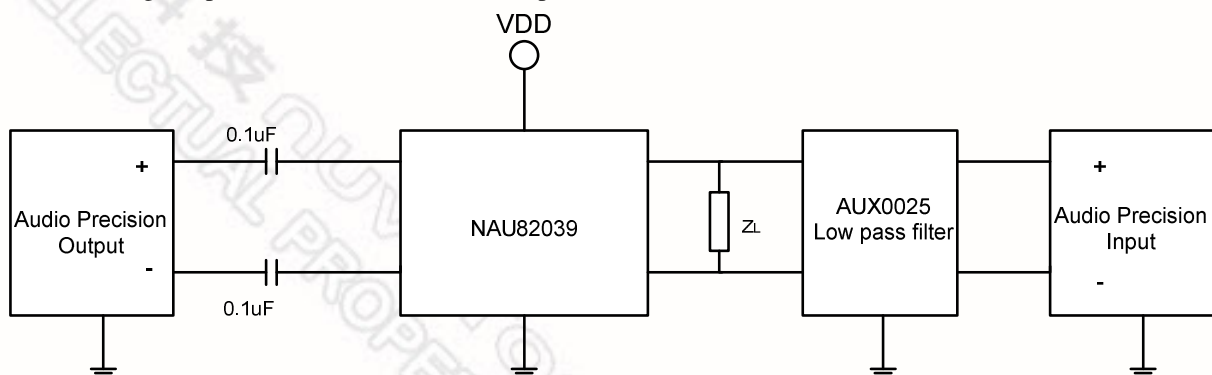

4 Typical Operating Characteristics

Conditions: $E_N = V_{DD} = 5V$, $V_{SS} = 0V$, $A_v = 12dB$, Bandwidth = 20Hz to 22 kHz, $T_A = 25\text{ }^\circ C$, unless otherwise noted

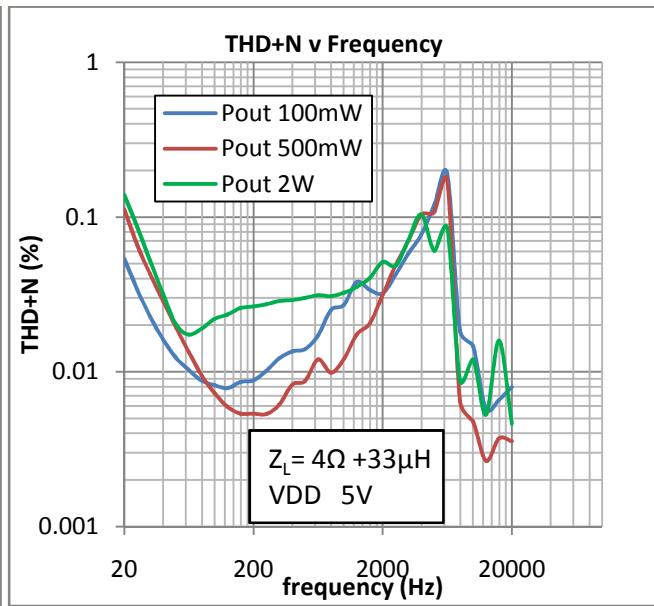
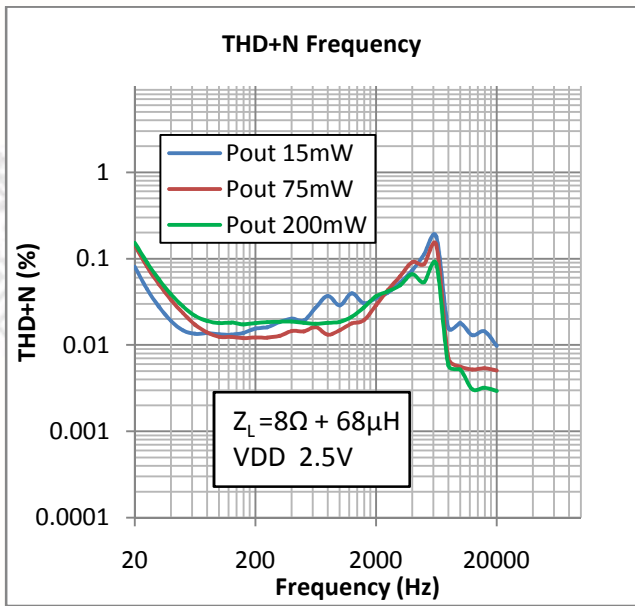
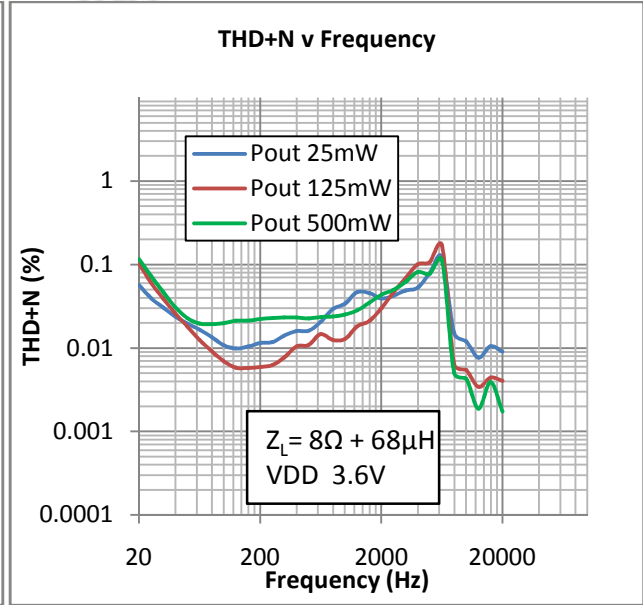
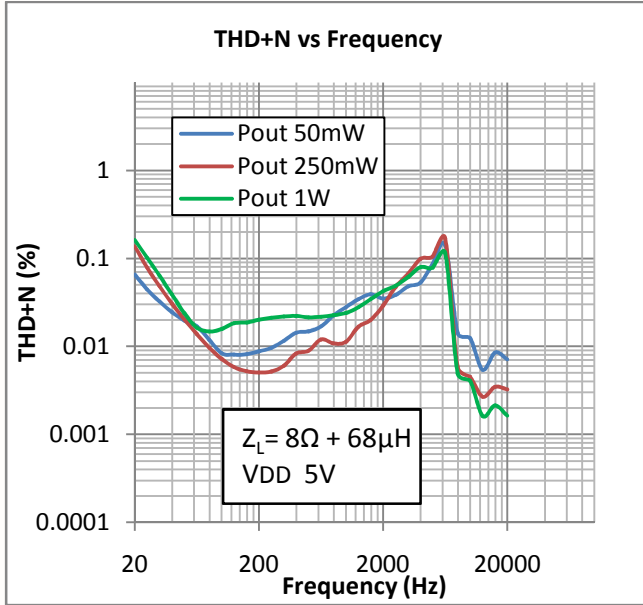

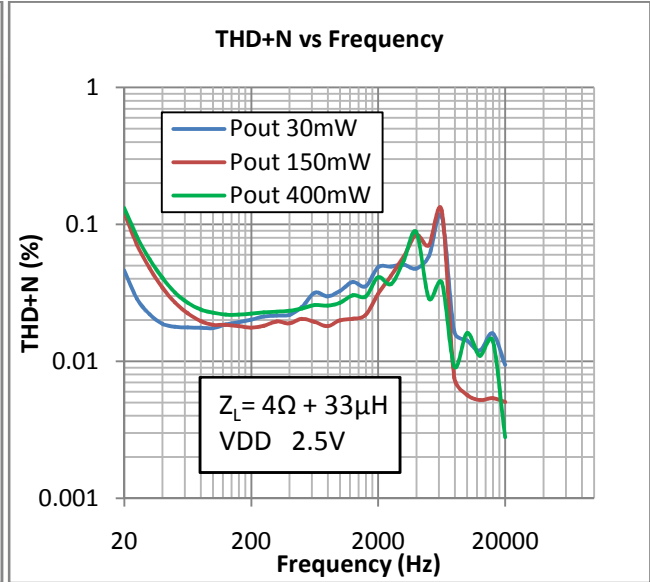
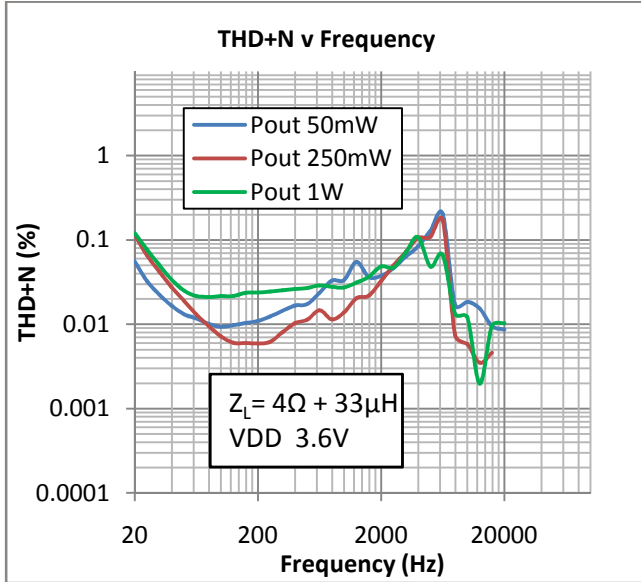

Note: All the above plots are captured with 0.1 μF input capacitor. It is recommended to use 2.2 μF input capacitor to get a flat low frequency response.

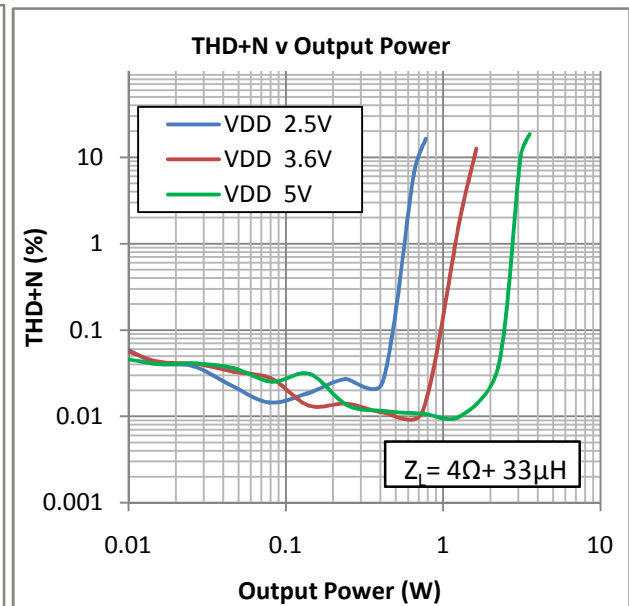
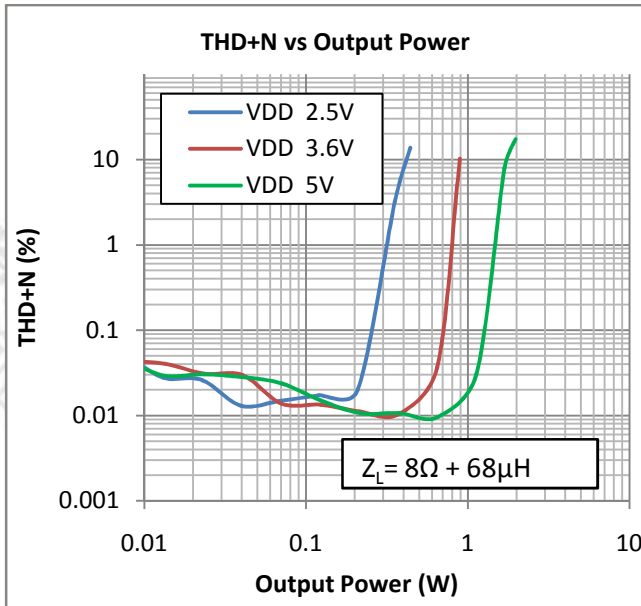

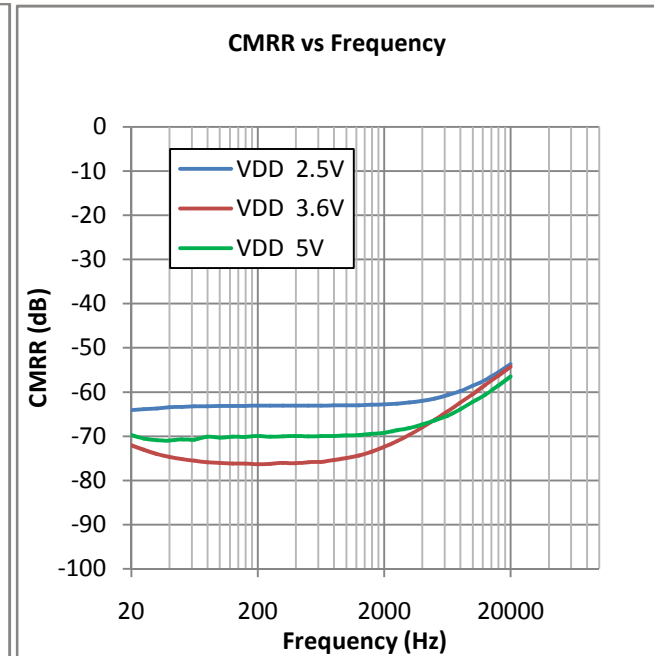
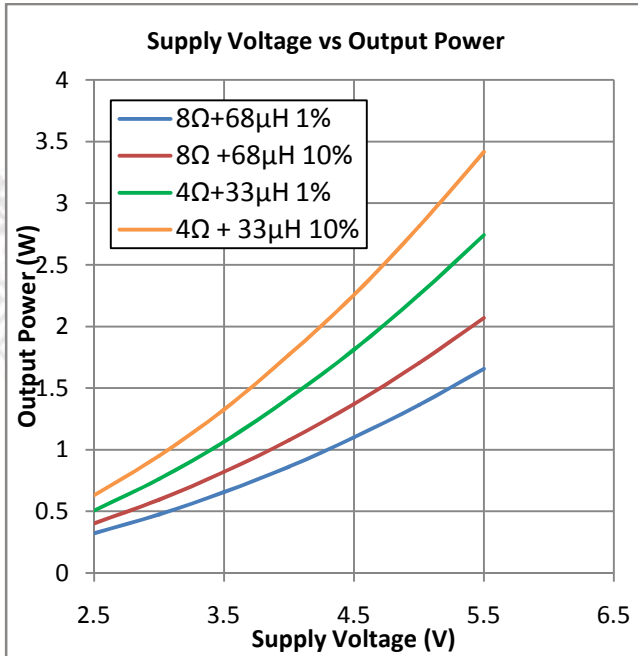
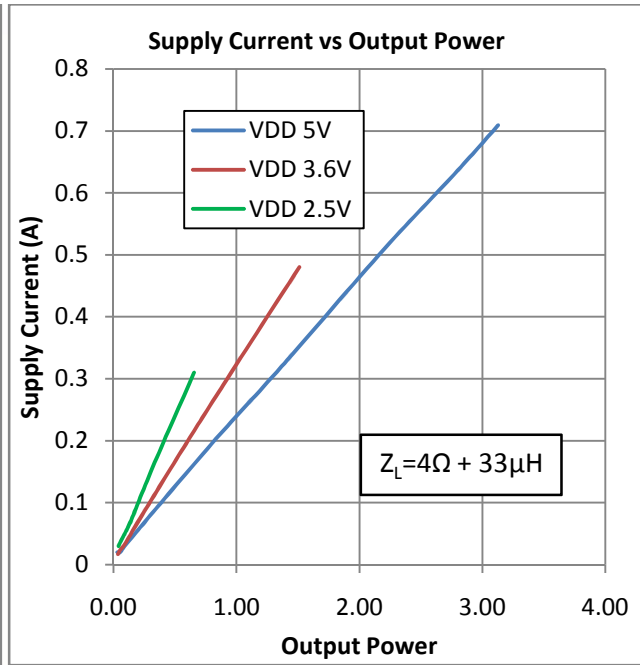
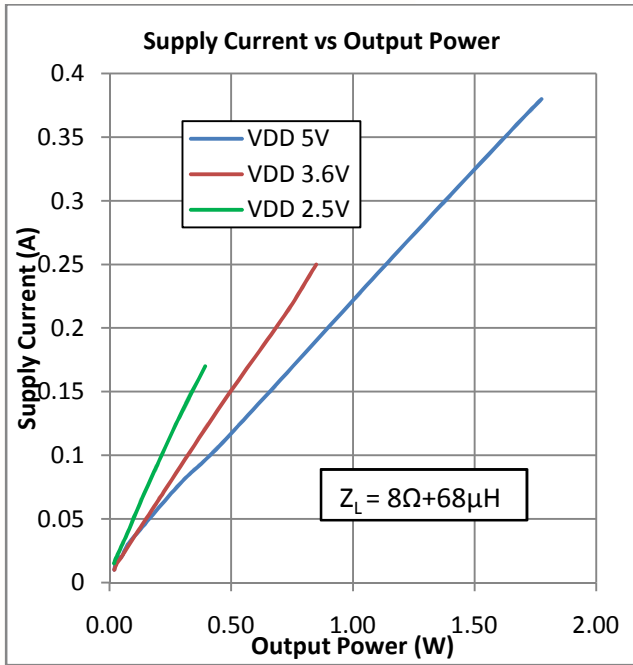

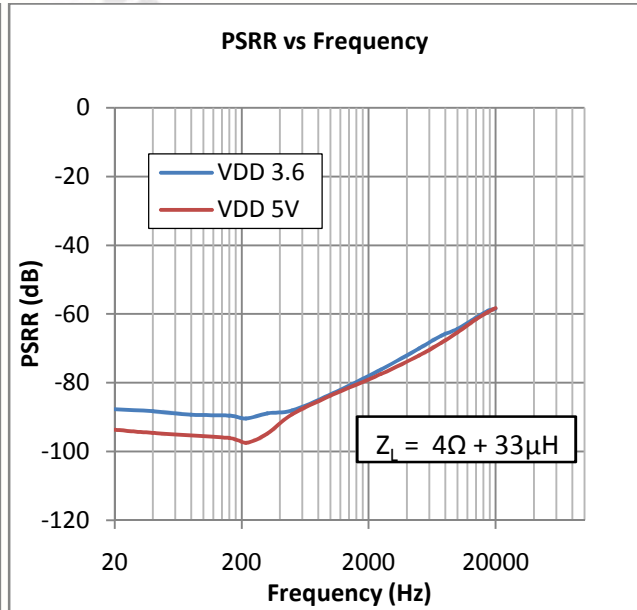
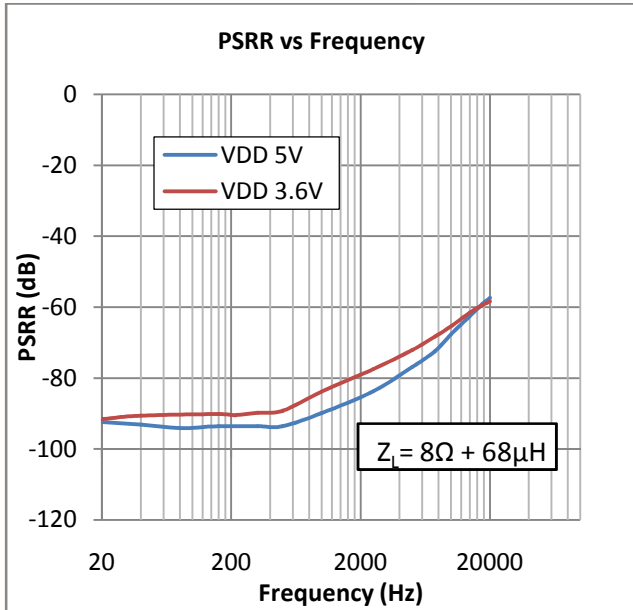

Note : The above PSRR plots are captured with input capacitors 2.2μF

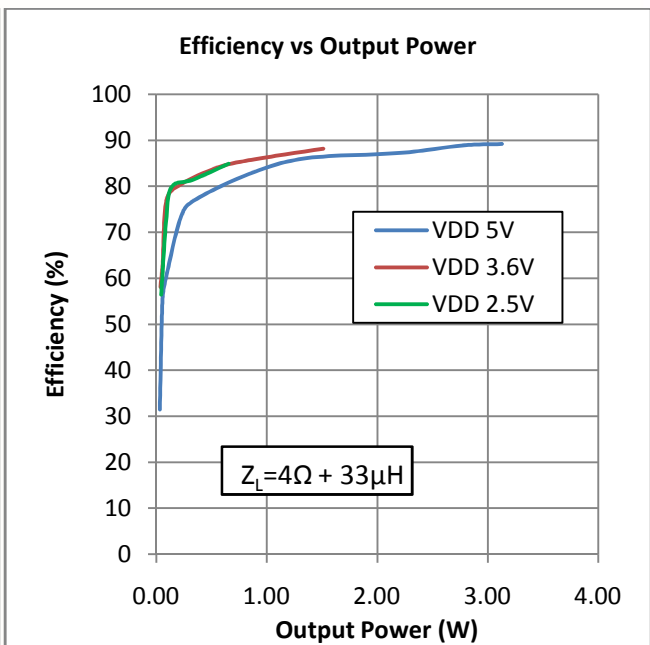
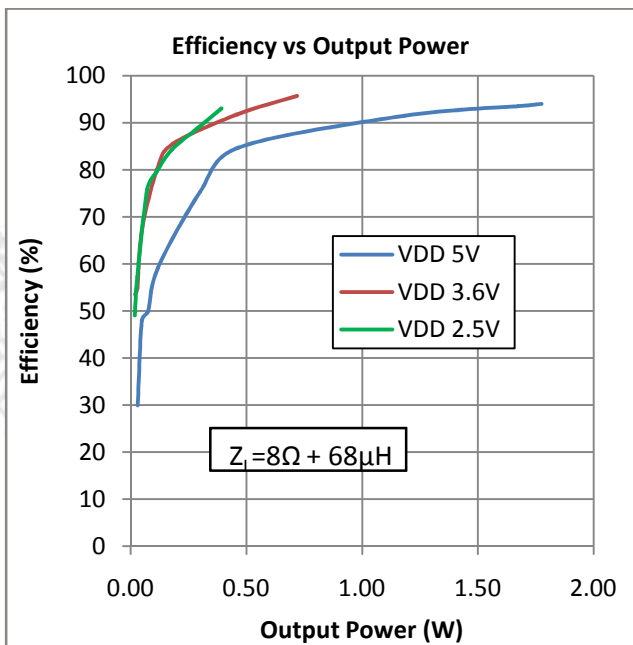

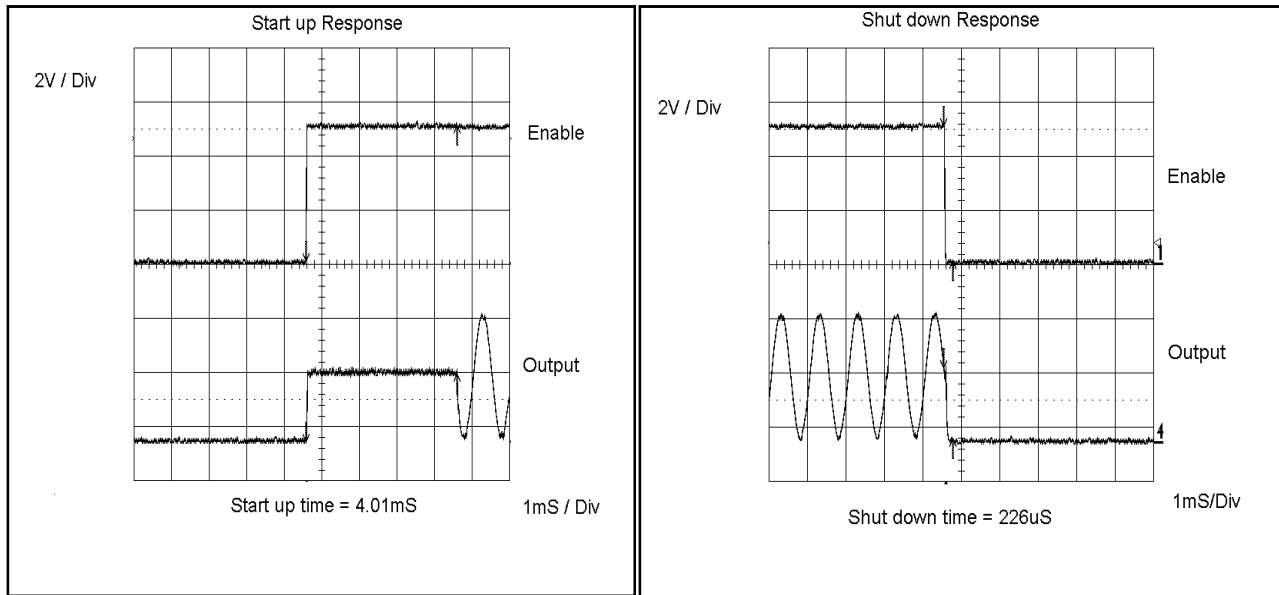

新唐科技 NUVO TON
INTELLECTUAL PROPERTY

5 Special Feature Description

The NAU82039 offers excellent quantity performance as high efficiency, high output power and low quiescent current. It also provides the following special features.

5.1 Device Protection

The NAU82039 includes device protection for three operating scenarios. They are

1. Thermal Overload
2. Short circuit
3. Supply under voltage

5.1.1 Thermal Overload Protection

When the device internal junction temperature reaches 150°C, the NAU82039 will disable the output drivers. When the device cools down and a safe operating temperature of 130°C has been reached for at least about 100ms, the output drivers will be enabled again.

5.1.2 Short Circuit Protection

If a short circuit is detected on any of the pull-up or pull-down devices on the output drivers for at least 16.7μs, the output drivers will be disabled for 100ms. The output drivers will then be enabled again and check for the short circuit. If the short circuit is still present, the output drivers are disabled after 16.7μs. This cycle will continue until the short circuit is removed. The short circuit threshold is 2.0A at 3.6V.

5.1.3 Supply under Voltage Protection

If the supply voltage drops under 2.1V, the output drivers will be disabled while the NAU82039 control circuitry still operates. This will avoid the battery supply to drag down too low before the host processor can safely shut down the devices on the system. If the supply drops further below 1.6 V the internal power on reset is activated and puts the entire device in power down state.

5.2 Power up and Power down Control

When the supply voltage ramps up, the internal power on reset circuit gets triggered. At this time all internal circuits will be set to power down state. The device can be enabled by setting the EN pin high. Upon setting the EN pin high, the device will go through an internal power up sequence in order to minimize 'pops' on the speaker output. The complete power up sequence will take about 4ms. The device will power down in about 30μs, when the EN pin is set low.

It is important to keep the input signal at zero amplitude or enable the mute condition in order to minimize the 'pops' when the EN pin is toggled.

6 Application Information

6.1 Application diagram

6.1.1 Single ended input configuration

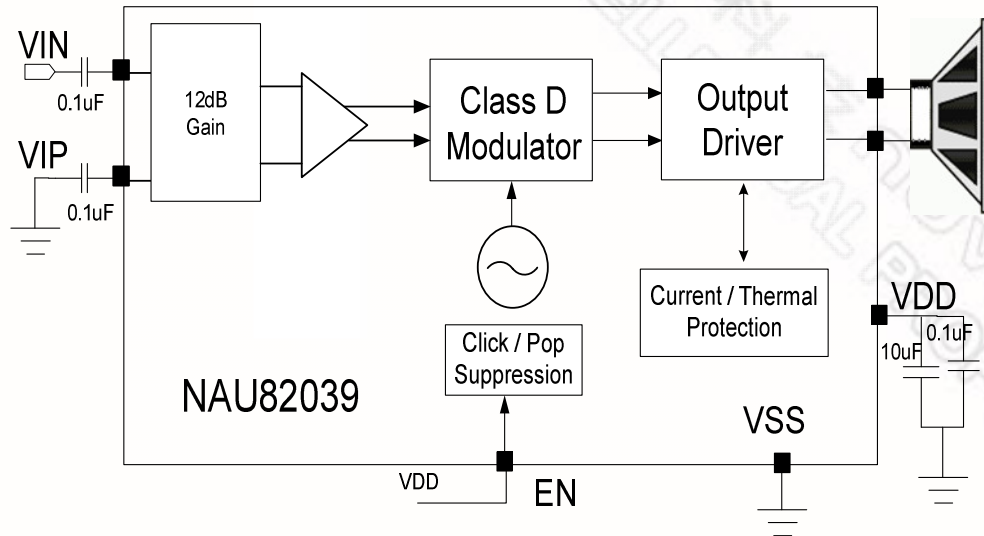

6.1.2 Differential input configuration

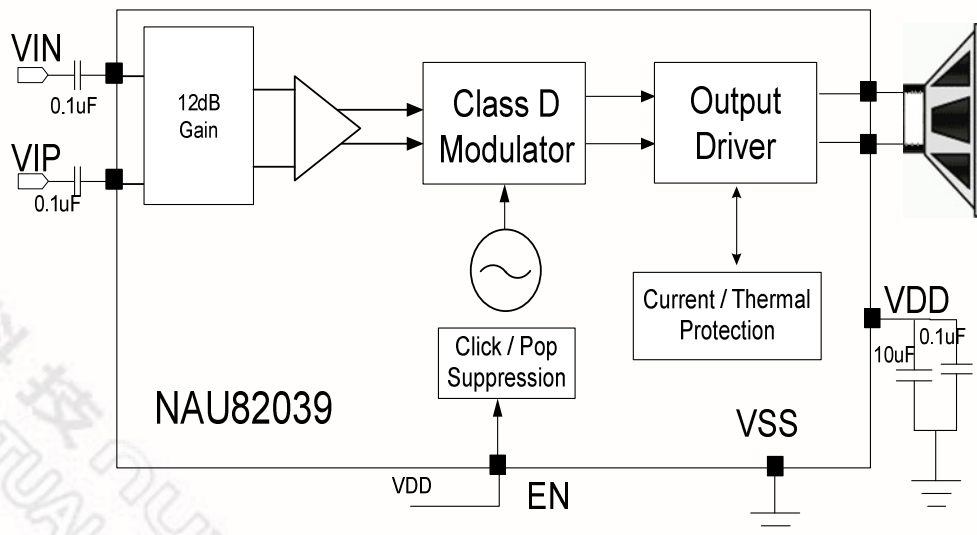

6.2 Component selection

6.2.1 Coupling Capacitors

An ac coupling capacitor (C_{in}) is used to block the dc content from the input source. The input resistance of the amplifier (R_{in}) together with the C_{in} will act as a high pass filter. So depending on the required cut off frequency the C_{in} can be calculated by using the following formula

$$C_{in} = \frac{1}{2\pi R_{in} f_c} \text{ Where } f_c \text{ is the desired cut off frequency of the High pass filter.}$$

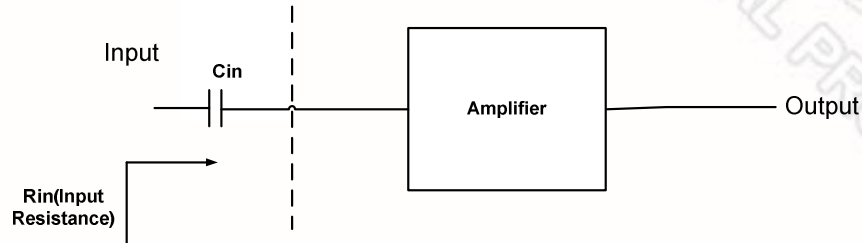

6.2.2 Bypass Capacitors

Bypass capacitors are required to remove the ac ripple on the VDD pins. The value of these capacitors depends on the length of the VDD trace. In most cases, 10 μ F and 0.1 μ F are enough to get the good performance.

6.3 Layout considerations

Good PCB layout and grounding techniques are essential to get the good audio performance. It is better to use low resistance traces as these devices are driving low impedance loads. The resistance of the traces has a significant effect on the output power delivered to the load. In order to dissipate more heat, use wide traces for the power and ground lines.

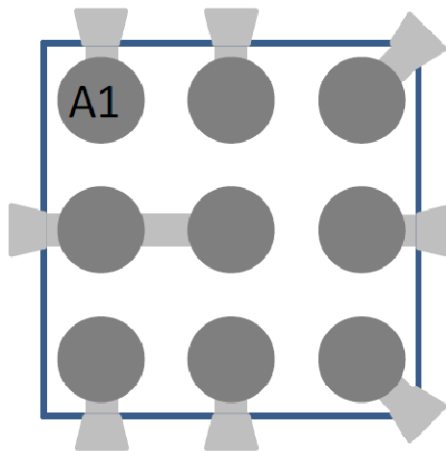

Recommended PCB footprint for NAU82039

The recommended PCB footprint for NAU82039 is shown in the above diagram.

6.4 Class D without filter

The NAU82039 is designed for use without any filter on the output line. That means the outputs can be directly connected to the speaker in the simplest configuration. This type of filter less design is suitable for portable applications where the speaker is very close to the amplifier. In other words, this is preferable in applications where the length of the traces between the speaker and amplifier is short. The following diagram shows this simple configuration.



NAU82039 outputs connected to speaker without filter circuit

6.5 Class D with filter

In some applications, short trace lengths are not possible because of speaker size limitations and other layout reasons. In these applications, the long traces will cause EMI issues. There are two types of filter circuits available to reduce the EMI effects. These are ferrite bead and LC filters.

6.5.1 Ferrite Bead filter

The ferrite bead filters are used to reduce the high frequency emissions. The typical circuit diagram is shown in the figure.

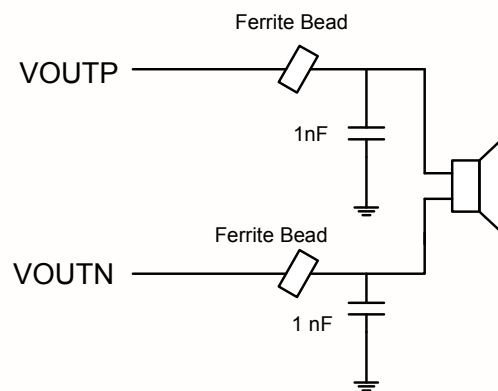

NAU82039 outputs connected to speaker with Ferrite Bead filter

The characteristic of ferrite bead is such that it offers higher impedance at high frequencies. For better EMI performance select ferrite bead which offers highest impedance at high frequencies, so that it will attenuate the signals at higher frequencies. Usually the ferrite beads have low impedance in the audio range, so it will act as a pass through filter in the audio frequency range.

6.5.2 LC filter

The LC filter is used to suppress the low frequency emissions. The following diagram shows the NAU82039 outputs connected to the speaker with LC filter circuit. R_L is the resistance of the speaker coil.

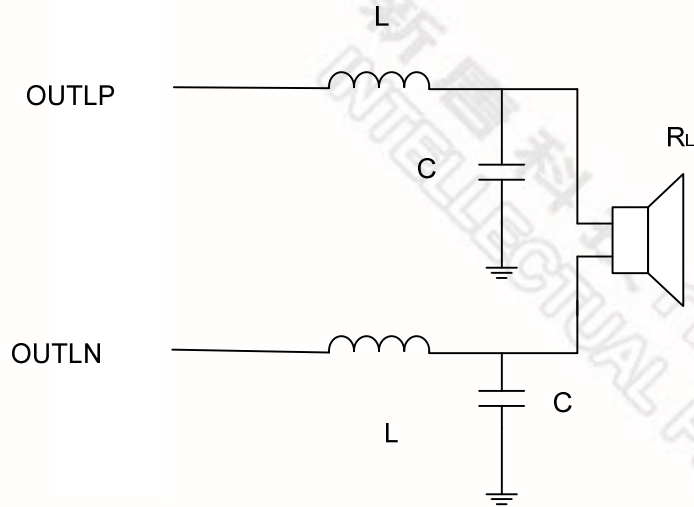

NAU82039 outputs connected to speaker with LC filter

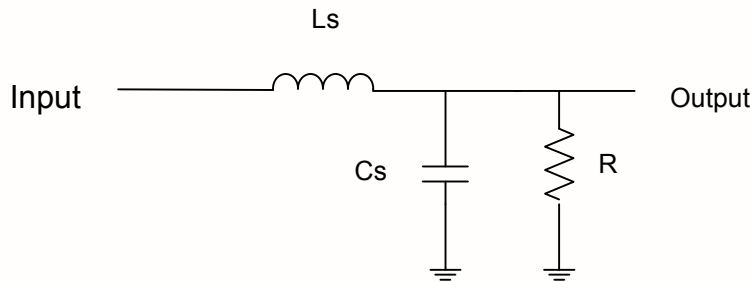

Standard Low pass LCR filter

The following are the equations for the critically damped ($\zeta = 0.707$) standard low pass LCR filter

$$2\pi f_c = \frac{1}{\sqrt{LC}} \quad f_c \text{ is the cutoff frequency}$$

$$\zeta = 0.707 = \frac{1}{2R} * \sqrt{\frac{L}{C}}$$

The L and C values for differential configuration can be calculated by duplicating the single ended configuration values and substituting $R_L = 2R$.

6.6 NAU82039 EMI performance

The NAU82039 includes a spread spectrum oscillator for reduced EMI. The PWM oscillator frequency typically sweeps in a range of 300 kHz +/- 15 kHz in order to spread the energy of the PWM pulses over a larger frequency band. In addition, slew rate control on the output drivers allows the application of 'filter less' loads, while suppressing EMI at high frequencies. The below graph shows the EMI performance of NAU82039 with and without ferrite beads and speaker cable length of 30cm.

6.6.1 Test Setup

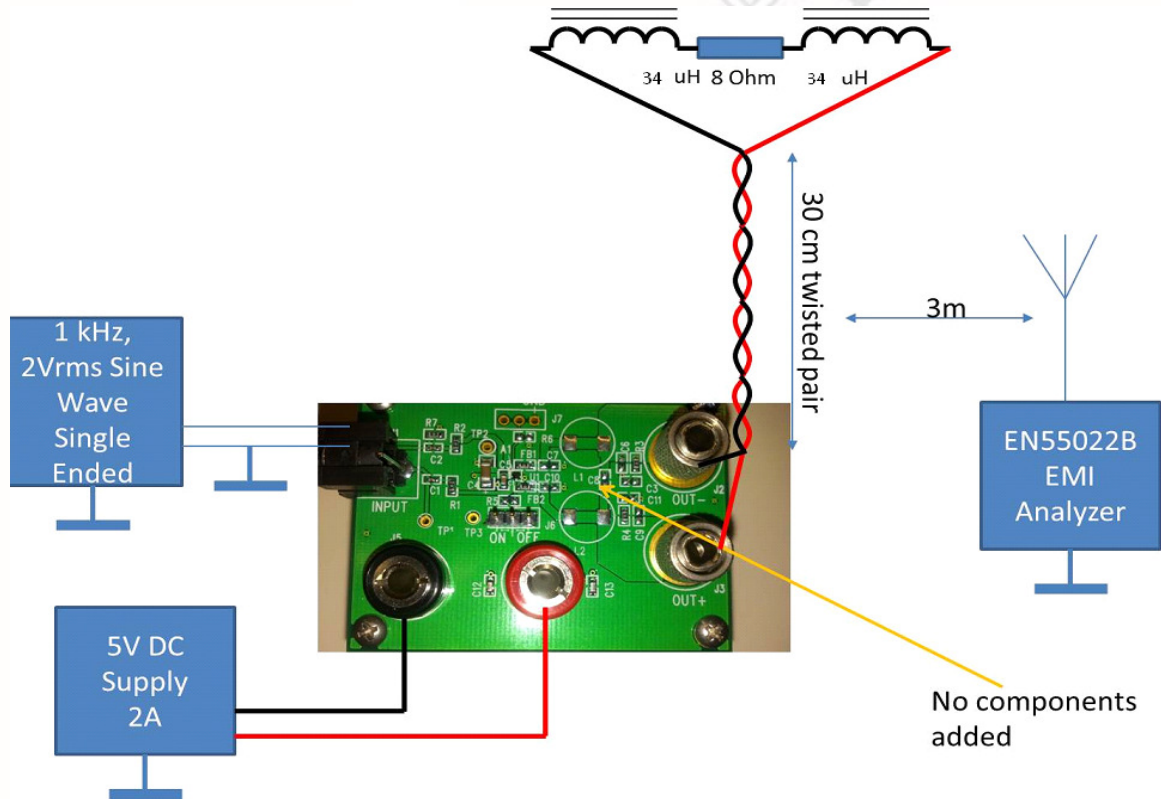

6.6.2 EMI performance with Ferrite bead (220 Ohm@100MHz)

The following are test conditions applied while doing the test:

wire length (cm)	30
wire type	twisted pair
Load Resistance (Ohm)	8
Load Inductance (μ H)	68
Output LC filter	No
Number of channels Tested	1
Supply Voltage (V)	5
Input Signal Frequency (Hz)	1000
Output Power (Watt)	0.1
Specification Standard	EN55022B

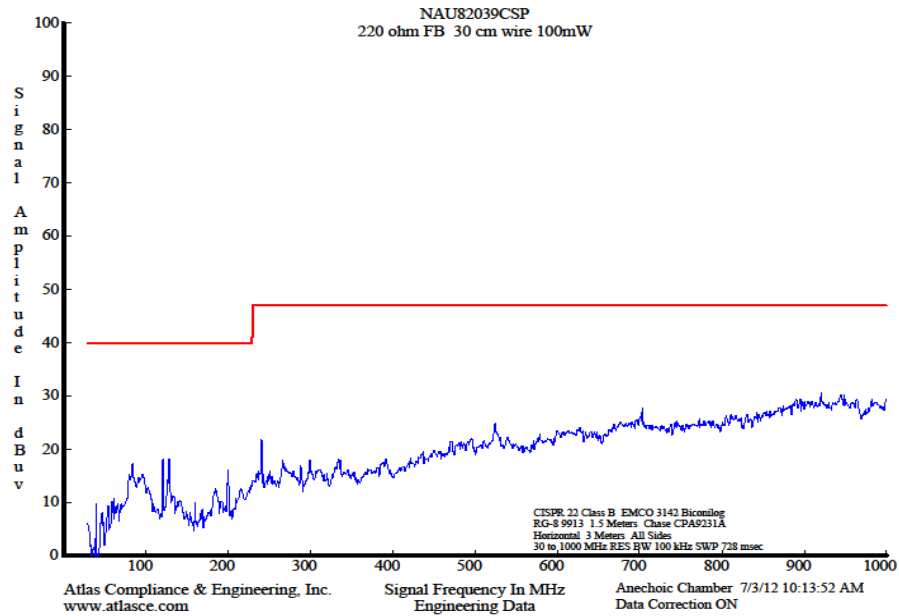

6.6.3 EMI performance without Ferrite bead

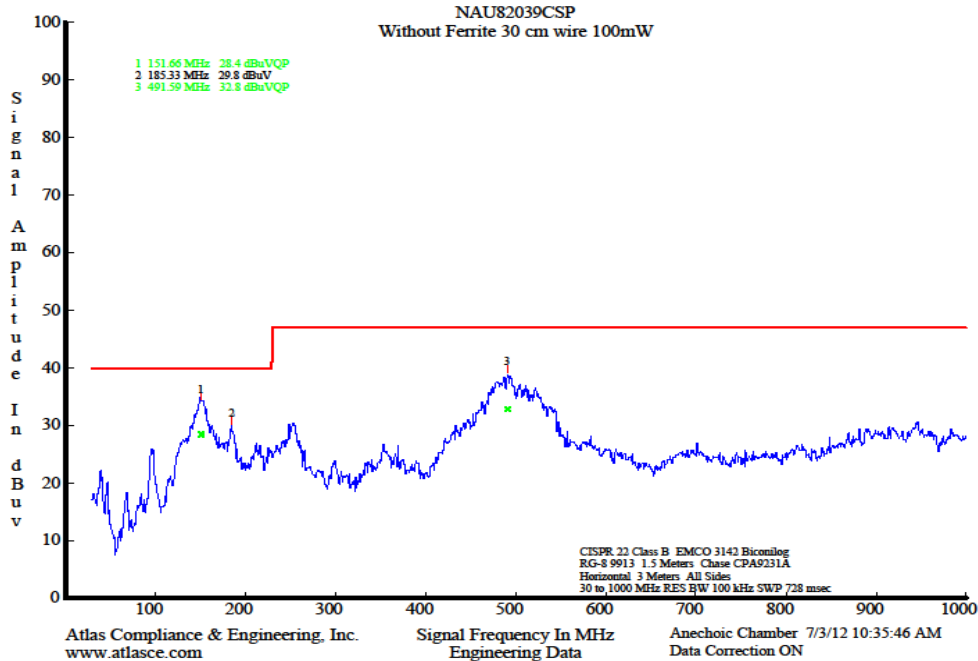

Note: The Blue line is peak measurement but limit is defined as QUASI peak measurement and green X represent QUASI – peak value at corresponding frequency and should be referred to when deciding pass/fail.

7 Package Dimensions

7.1 9 bump WCSP (0.4mm pitch)(1.21mm x1.23mm)

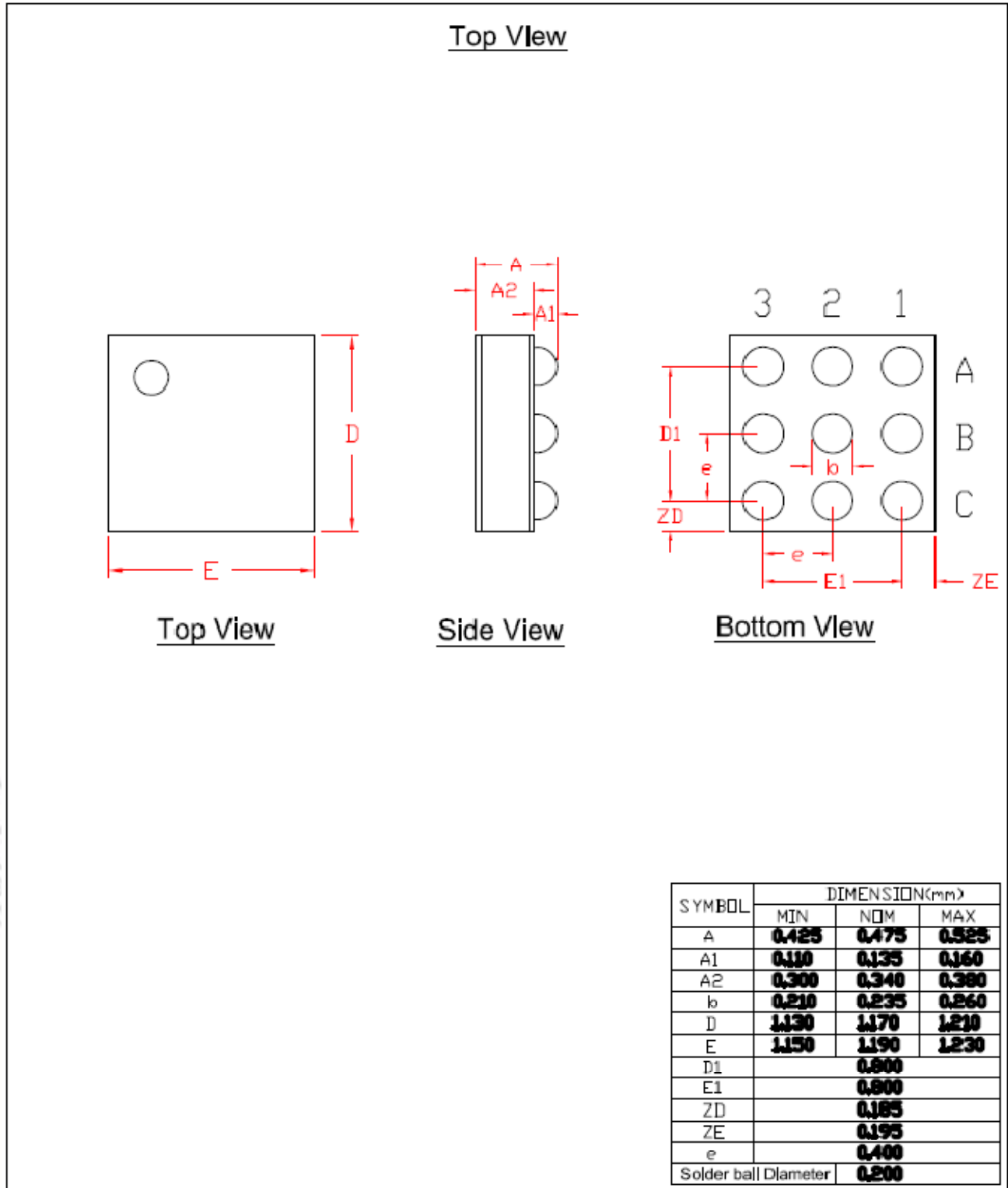

8 Ordering Information

Nuvoton Part Number Description

NAU 82039VG

Package Material:

G = Pb-free Package

Package Type:

V = 9-bump WCSP Package

Version History

VERSION	DATE	PAGE	DESCRIPTION
Rev1.0	Aug, 2012	NA	Preliminary Revision

Table 2 Version History

Important Notice

Nuvoton products are not designed, intended, authorized or warranted for use as components in systems or equipment intended for surgical implantation, atomic energy control instruments, airplane or spaceship instruments, transportation instruments, traffic signal instruments, combustion control instruments, or for other applications intended to support or sustain life. Furthermore, Nuvoton products are not intended for applications wherein failure of Nuvoton products could result or lead to a situation wherein personal injury, death or severe property or environmental damage could occur.

Nuvoton customers using or selling these products for use in such applications do so at their own risk and agree to fully indemnify Nuvoton for any damages resulting from such improper use or sales.