



Chipsmall Limited consists of a professional team with an average of over 10 year of expertise in the distribution of electronic components. Based in Hongkong, we have already established firm and mutual-benefit business relationships with customers from,Europe,America and south Asia,supplying obsolete and hard-to-find components to meet their specific needs.

With the principle of “Quality Parts,Customers Priority,Honest Operation,and Considerate Service”,our business mainly focus on the distribution of electronic components. Line cards we deal with include Microchip,ALPS,ROHM,Xilinx,Pulse,ON,Everlight and Freescale. Main products comprise IC,Modules,Potentiometer,IC Socket,Relay,Connector.Our parts cover such applications as commercial,industrial, and automotives areas.

We are looking forward to setting up business relationship with you and hope to provide you with the best service and solution. Let us make a better world for our industry!



Contact us

Tel: +86-755-8981 8866 Fax: +86-755-8427 6832

Email & Skype: info@chipsmall.com Web: www.chipsmall.com

Address: A1208, Overseas Decoration Building, #122 Zhenhua RD., Futian, Shenzhen, China



NO.:	VERSION: 1.0	PAGE: 1
------	--------------	---------

NAU83P20 Demo Board Standalone Setup

NO.:	VERSION: 1.0	PAGE: 2
------	--------------	---------

1	Introduction.....	3
2	Overview	3
2.1	NAU83P20 Demo Board Overview.....	3
2.1.1	Power Down Button.....	3
2.1.2	Reset Button	3
2.1.3	NAU82011 (x2).....	3
2.1.4	NAU83P20.....	4
2.1.5	NAU8402	4
2.1.6	LED Warning Lights	4
2.2	Connectors and Jumpers.....	4
2.2.1	Board Connector (J3).....	4
2.2.2	Slew Control (J6).....	5
2.2.3	Positive Audio Input (J4/J7)	5
2.2.4	Negative Audio Input (J5)	5
2.2.5	I2S Header for NAU8402 (J8).....	6
2.2.6	NAU82011 and NAU8402 Power Select Jumpers (J1/J2).....	6
2.2.7	Fault Signal to Power Down Jumper (J9).....	6
2.2.8	Audio Outputs after LRC Filter (OUT1A/OUT1B/OUT2A/OUT2B).....	6
2.2.9	VDD High Voltage Connection	6
2.2.10	Power Input (7V-25V).....	7
3	Setup	8
3.1	Analog Audio Input.....	8
3.2	Digital Audio Input.....	9

NO.:	VERSION:	1.0	PAGE:	3
------	----------	-----	-------	---

1 Introduction

This document will cover the setup of the NAU83P20 Demo Board in standalone mode.

2 Overview

2.1 NAU83P20 Demo Board Overview

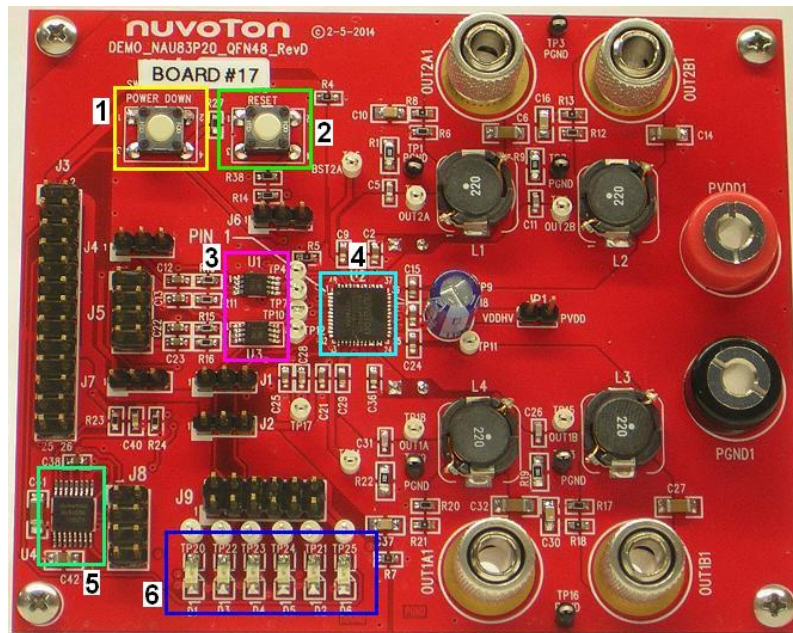

2.1.1 Power Down Button

While depressed the NAU83P20 will enter into a low power mode, all outputs will be disabled and all inputs will enter into a high impedance state. When the power down button is released the NAU83P20 will resume normal operation.

2.1.2 Reset Button

When pressed the faults of the NAU83P20 will be reset into their power up state.

2.1.3 NAU82011 (x2)

The NAU82011 is a 3W Class D audio amplifier, these provide the Class D input signal required by the NAU83P20.

NO.:	VERSION:	1.0	PAGE:	4
------	----------	-----	-------	---

2.1.4 NAU83P20

The NAU83P20 is a 20W Class D audio amplifier and is the chip featured on the evaluation board.

2.1.5 NAU8402

The NAU8402 is a digital to analog converter that will take a digital input from the I2S Input Header (J8, 2.2.5) and convert it into an analog signal that is fed to the NAU82011's. The maximum output from the NAU8402 is 2Vrms.

2.1.6 LED Warning Lights

The LED warning lights will become illuminated if the chip detects any of the following faults: Fault (D1), Over Current (D3), Under Voltage (D4), Temperature Warning (D5), Over Temperature (D2), and Over Current Latch (D6). Full descriptions of these faults can be found in the data sheet.

2.2 Connectors and Jumpers

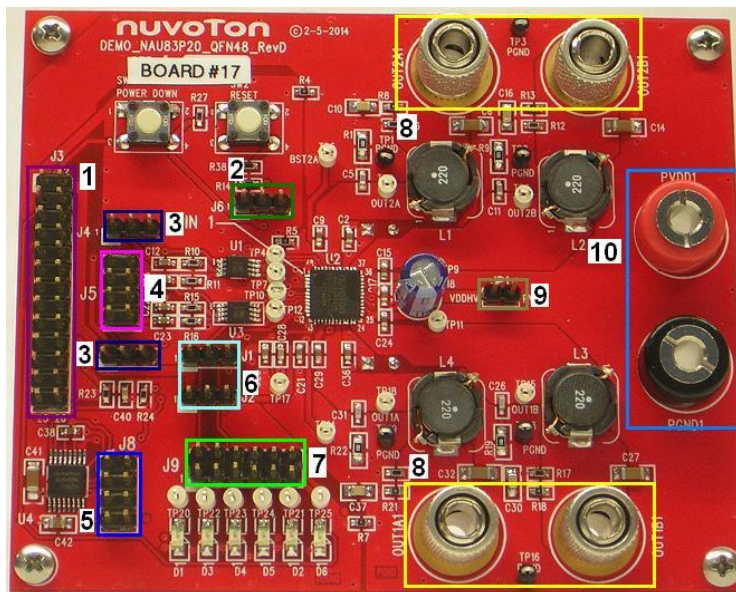

2.2.1 Board Connector (J3)

This male connector will be used to toggle the enable pins of the NAU83P20 (see 2.1.4), NAU82011s (see 2.1.3), and NAU8402 (see 2.1.5) and for analog audio input.

NO.:	VERSION: 1.0	PAGE: 5
------	--------------	---------

2.2.2 Slew Control (J6)

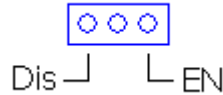

A jumper placed between pins 1-2 will disable the slew control and a jumper placed between pins 2-3 will enable the slew control. *Slew enabled is recommended.*

2.2.3 Positive Audio Input (J4/J7)

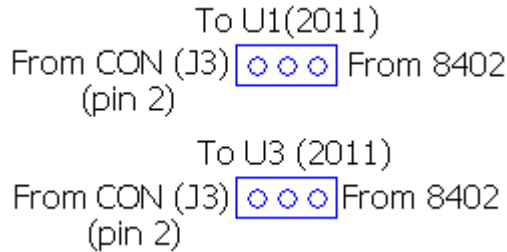

If the jumpers are placed in the left position the positive audio input will be fed from the Board Connector (J3) to the NAU82011's. In the right position the positive audio input will be taken from the NAU8402.

2.2.4 Negative Audio Input (J5)

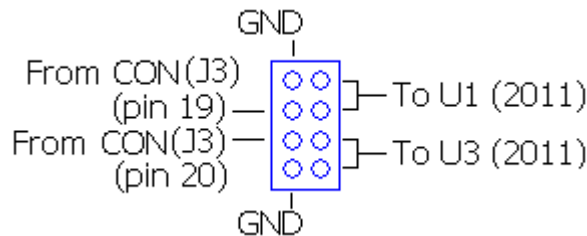

If the jumpers are placed in the center positions the negative audio input will be fed from the Board Connector (J3) to the NAU82011's. In the outer positions the negative audio inputs will be grounded allowing for single ended use from the Board Connector (J3) or the NAU8402.

NO.:	VERSION: 1.0	PAGE: 6
------	--------------	---------

2.2.5 I2S Input Header for NAU8402 (J8)

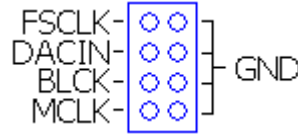

This header is used to input I2S signals to the NAU8402.

2.2.6 NAU82011 and NAU8402 Power Select Jumpers (J1/J2)

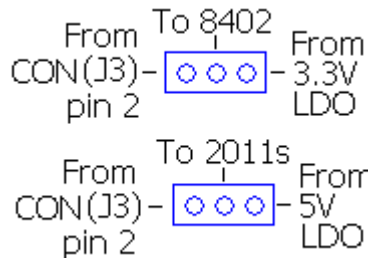

These jumpers allow the power source of the NAU82011’s and the NAU8402 to be selected. In the left position the power will come from the Board Connector (J3) in the right position the power will come from the NAU83P20’s onboard LDOs. Please note that while the NAU82011s can run between 2.5V and 5.5V the NAU8402 can only operate between 3V and 3.6V. *It is recommended to use the on chip LDO whenever possible.*

2.2.7 Fault Signal to Power Down Jumper (J9)

This jumper can be used to connect any of the fault signals directly to the power down pin, forcing the chip into power down whenever the selected fault is detected. Pins are matched with the LED order listed in section 2.1.6 in this document. *It is recommended to connect the Shutdown Latch (D6), pins 11-12, while in use.*

2.2.8 Audio Outputs after LRC Filter (OUT1A/OUT1B/OUT2A/OUT2B)

Audio output banana plugs for speakers or audio testing, these outputs are after the onboard LRC filter.

2.2.9 VDD High Voltage Connection

This jumper connects the PVDD1/2 (NAU83P20 Class D drivers) Pins to the VDDHV (NAU83P20 Circuitry) Pin. If this jumper is not in place an external power supply needs to be connected to the VDDHV side of the jumper so that the chip’s internal circuitry can function.

NO.:	VERSION: 1.0	PAGE: 7
------	--------------	---------

2.2.10 Power Input (7V-25V)

Banana jacks to provide power and ground to the board.

NO.:	VERSION: 1.0	PAGE: 8
------	--------------	---------

3 Setup

3.1 Analog Audio Input

3.1.1 Use Board Connector (J3) to apply the connections pictured below:

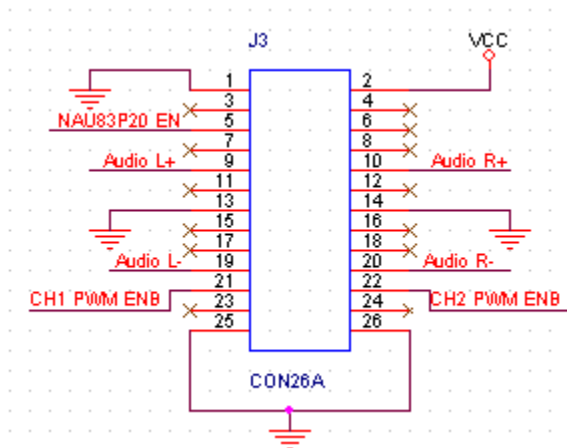

Note: CH1 PWM EN and CH2 PWM EN should be pulled to GND to Enable.

- 3.1.2 Select Desired Slew Control (J6), section 2.2.2
- 3.1.3 Place Positive Audio Input Jumpers (J4/J7) to take signal from the Board Connector, section 2.2.3
- 3.1.4 Select Differential or Single Ended Operation Using the Negative Audio Input Jumper (J5), section 2.2.4
- 3.1.5 Select Desired Power Input Source to the NAU82011s (J2), section 2.2.6. If using an external supply to power the NAU82011s it should be connected to pin 2 of J3. **Note:** NAU82011 Supply Voltage is 2.5-5.5V.
- 3.1.6 Power Input to the NAU8402 (J1) should be left open as it is not in use, section 2.2.6
- 3.1.7 Apply Power to banana jacks (PVDD/PGND), section 2.2.10. **Note:** NAU83P20 Supply Voltage is 7V-25V

NO.:	VERSION: 1.0	PAGE: 9
------	--------------	---------

3.2 Digital Audio Input

3.2.1 Use Board Connector (J3) to apply the connections pictured below:

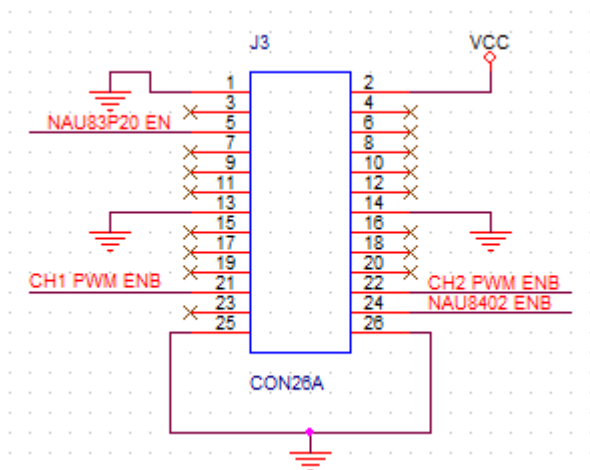

Note: CH1 PWM EN, CH2 PWM EN, and NAU8402 EN should be pulled to GND to Enable.

3.2.2 Select Desired Slew Control (J6), section 2.2.2

3.2.3 Place Positive Audio Input Jumpers to take signal from the NAU8402 Digital to Analog Converter, Section 2.2.3

3.2.4 Select Single Ended Operation Using the Negative Audio Input Jumper (J5), section 2.2.4

3.2.5 Select Desired Power Input Source to the NAU82011s (J2), section 2.2.6. If using an external supply to power the NAU82011s it should be connected to pin 2 of J3. *Note: NAU82011 Supply Voltage is 2.5-5.5V.*

3.2.6 Select Desired Power Input Source to the NAU8402 (J1), section 2.2.6. If using an external supply to power the NAU8402 it should be connected to pin 2 of J3. *Note: NAU8402 Supply Voltage is 3.0-3.6V.*

3.2.7 Apply Power to banana jacks (PVDD/PGND), section 2.2.10. *Note: NAU83P20 Supply Voltage is 7V-25V*

3.2.8 Apply I2S signals to I2S Header (J8), section 2.2.5