



Chipsmall Limited consists of a professional team with an average of over 10 year of expertise in the distribution of electronic components. Based in Hongkong, we have already established firm and mutual-benefit business relationships with customers from,Europe,America and south Asia,supplying obsolete and hard-to-find components to meet their specific needs.

With the principle of “Quality Parts,Customers Priority,Honest Operation,and Considerate Service”,our business mainly focus on the distribution of electronic components. Line cards we deal with include Microchip,ALPS,ROHM,Xilinx,Pulse,ON,Everlight and Freescale. Main products comprise IC,Modules,Potentiometer,IC Socket,Relay,Connector.Our parts cover such applications as commercial,industrial, and automotives areas.

We are looking forward to setting up business relationship with you and hope to provide you with the best service and solution. Let us make a better world for our industry!



## Contact us

Tel: +86-755-8981 8866 Fax: +86-755-8427 6832

Email & Skype: info@chipsmall.com Web: www.chipsmall.com

Address: A1208, Overseas Decoration Building, #122 Zhenhua RD., Futian, Shenzhen, China



# NB3H63143G

## 3.3 V / 2.5 V Programmable OmniClock Generator

### with Single Ended (LVCMOS/LVTTL) and Differential (LVPECL/LVDS/ HCSL/CML) Outputs with Individual Output Enable and Individual VDDO

The NB3H63143G, which is a member of the OmniClock family, is a one-time programmable (OTP), low power PLL-based clock generator that supports any output frequency from 8 kHz to 200 MHz. The device accepts fundamental mode parallel resonant crystal or a single ended (LVCMOS/LVTTL) reference clock as input. It generates either three single ended (LVCMOS/LVTTL) outputs, or one single ended output and one differential (LVPECL/LVDS/HCSL/CML) output. The output signals can be modulated using the spread spectrum feature of the PLL (programmable spread spectrum type, deviation and rate) for applications demanding low electromagnetic interference (EMI). Individual output enable pins OE[2:0] are available to enable/disable the outputs. Individual output voltage pins VDDO[2:0] are available to independently set the output voltage of each output. Up to four different configurations can be written into the device memory. Two selection pins (SEL[1:0]) allow the user to select the configuration to use. Using the PLL bypass mode, it is possible to get a copy of the input clock on any or all of the outputs. The device can be powered down using the Power Down pin (PD#). It is possible to program the internal input crystal load capacitance and the output drive current provided by the device. The device also has automatic gain control (crystal power limiting) circuitry which avoids the device overdriving the external crystal.

#### Features

- Member of the OmniClock Family of Programmable Clock Generators
- Operating Power Supply: 3.3 V  $\pm$ 10%, 2.5 V  $\pm$ 10%
- I/O Standards
  - ◆ Inputs: LVCMOS/LVTTL, Fundamental Mode Crystal
  - ◆ Outputs: 1.8 V to 3.3 V LVCMOS/LVTTL
  - ◆ Outputs: LVPECL, LVDS, HCSL and CML
- 3 Programmable Single Ended (LVCMOS/LVTTL) Outputs from 8 kHz to 200 MHz
- 1 Programmable Differential Clock Output up to 200 MHz
- Input Frequency Range
  - ◆ Crystal: 3 MHz to 50 MHz
  - ◆ Reference Clock: 3 MHz to 200 MHz
- Configurable Spread Spectrum Frequency Modulation Parameters (Type, Deviation, Rate)
- Individual Output Enable Pins
- Independent Output Voltage Pins



ON Semiconductor®

[www.onsemi.com](http://www.onsemi.com)



1

QFN16  
CASE 485AE

#### MARKING DIAGRAM

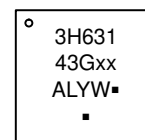

3H63143G = Specific Device Code  
xx = Specific Program Code (Default '00' for Unprogrammed Part)  
A = Assembly Location  
L = Wafer Lot  
Y = Year  
W = Work Week  
▪ = Pb-Free Package

(Note: Microdot may be in either location)

#### ORDERING INFORMATION

See detailed ordering and shipping information on page 23 of this data sheet.

- Programmable Internal Crystal Load Capacitors
- Programmable Output Drive Current for Single Ended Outputs
- Power Saving Mode through Power Down Pin
- Programmable PLL Bypass Mode
- Programmable Output Inversion
- Programming and Evaluation Kit Available for Field Programming and Quick Evaluation
- Temperature Range  $-40^{\circ}\text{C}$  to  $85^{\circ}\text{C}$
- Packaged in 16-pin QFN
- These are Pb-Free Devices

#### Typical Applications

- eBooks and Media Players
- Smart Wearables, Smart Phones, Portable Medical and Industrial Equipment
- Set Top Boxes, Printers, Digital Cameras and Camcorders

# NB3H63143G

## BLOCK DIAGRAM

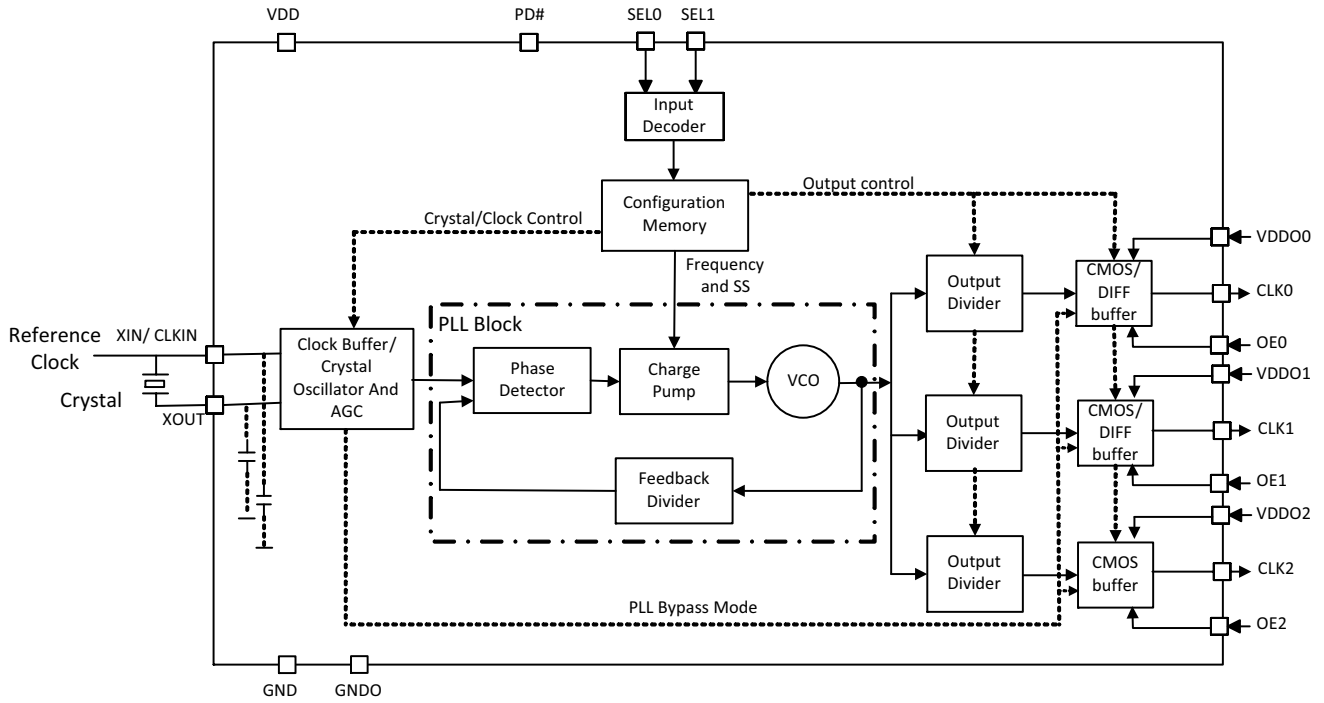

**Notes:**

1. CLK0 and CLK1 can be configured to be one LVPECL, LVDS, HCSSL or CML output, or two single ended LVCMOS/LVTTL outputs.
2. Dotted lines are the programmable control signals to internal IC blocks.
3. OE[2:0], SEL[1:0] have internal pull up resistors. PD# has internal pull down resistor.

**Figure 1. Simplified Block Diagram**

## PIN FUNCTION DESCRIPTION

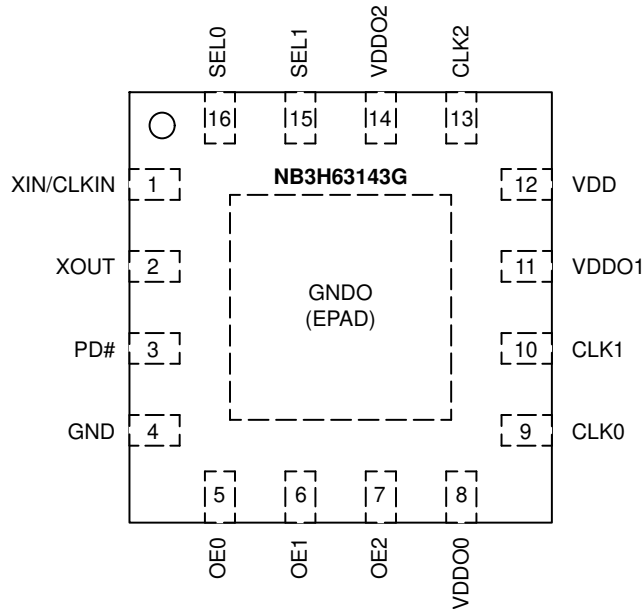

**Figure 2. Pin Connections (Top View) – QFN16 (with EPAD)**



# NB3H63143G

**Table 1. PIN DESCRIPTION**

Pin No.	Pin Name	Pin Type	Description
1	XIN/CLKIN	Input	3 MHz to 50 MHz crystal input connection or an external single ended reference input clock between 3 MHz and 200 MHz.
2	XOUT	Output	Crystal output. Float this pin when external reference clock is connected at XIN.
3	PD#	Input	Asynchronous LVCMOS/LVTTL input. Active Low Master Reset to disable the device and set outputs Low. Internal pull-down resistor. This pin needs to be pulled High for normal operation of the chip.
4	GND	Ground	Power supply ground.
5, 6, 7	OE[2:0]	Input	2-Level LVCMOS/LVTTL Inputs for Enabling/Disabling output clocks CLK[2:0] respectively. Internal pull-up resistor.
8	VDDO0	Power	CLK0 Output power supply $\leq$ VDD
9	CLK0	SE/DIFF Output	Supports 8 kHz to 200 MHz Single Ended (LVCMOS/LVTTL) signals or Differential (LVPECL/LVDS/HCSL/CML) signals. Using PLL Bypass mode, the output can also be a copy of the input clock. The single ended output will be LOW and differential outputs will be complementary LOW/HIGH until the PLL has locked and the frequency has stabilized.
10	CLK1	SE/DIFF Output	Supports 8 kHz to 200 MHz Single Ended (LVCMOS/LVTTL) signals or Differential (LVPECL/LVDS/HCSL/CML) signals. Using PLL Bypass mode, the output can also be a copy of the input clock. The single ended output will be LOW and differential outputs will be complementary LOW/HIGH until the PLL has locked and the frequency has stabilized.
11	VDDO1	Power	CLK1 Output power supply $\leq$ VDD
12	VDD	Power	3.3V / 2.5V power supply.
13	CLK2	SE Output	Supports 8 kHz to 200 MHz Single Ended (LVCMOS/LVTTL) signals. Using PLL Bypass mode, the output can also be a copy of the input clock. The single ended output will be LOW until the PLL has locked and the frequency has stabilized.
14	VDDO2	Power	CLK2 Output power supply $\leq$ VDD
15, 16	SEL[1:0]	Input	2-Level LVCMOS/LVTTL Inputs for Configuration Selection. Configuration parameters include individual output frequencies, spread spectrum configuration, enable/disable status of each output, output type, internal crystal load capacitance configuration, etc. Configuration can be switched dynamically, but may require the PLL to re-lock. Internal pull-up resistor.
EPAD	GNDO	Ground	Power supply ground for Outputs.

**Table 2. OUTPUT CONFIGURATION SELECT FUNCTION TABLE**

SEL1	SEL0	Output Configuration
L	L	I
L	H	II
H	L	III
H	H	IV

**Table 3. POWER DOWN FUNCTION TABLE**

PD#	Function
0	Device Powered Down
1	Device Powered Up

**Table 4. OUTPUT ENABLE FUNCTION TABLE**

OE[2:0]	Function
0	CLK Disabled
1	CLK Enabled

## TYPICAL CRYSTAL PARAMETERS

Crystal: Fundamental Mode Parallel Resonant  
Frequency: 3 MHz to 50 MHz

**Table 5. MAX CRYSTAL LOAD CAPACITORS RECOMMENDATION**

Crystal Frequency Range	Max Cap Value
3 MHz – 30 MHz	20 pF
30 MHz – 50 MHz	10 pF

Shunt Capacitance (C0): 7 pF (Max)

Equivalent Series Resistance 150  $\Omega$  (Max)

# NB3H63143G

## FUNCTIONAL DESCRIPTION

The NB3H63143G is a 3.3 V/2.5 V programmable, single ended/differential clock generator, designed to meet the timing requirements for consumer and portable markets. It has a small package size and it requires low power during operation and while in standby. This device provides the

ability to configure a number of parameters as detailed in the following section. The One-Time Programmable memory allows programming and storing of up to four configurations in the memory space.

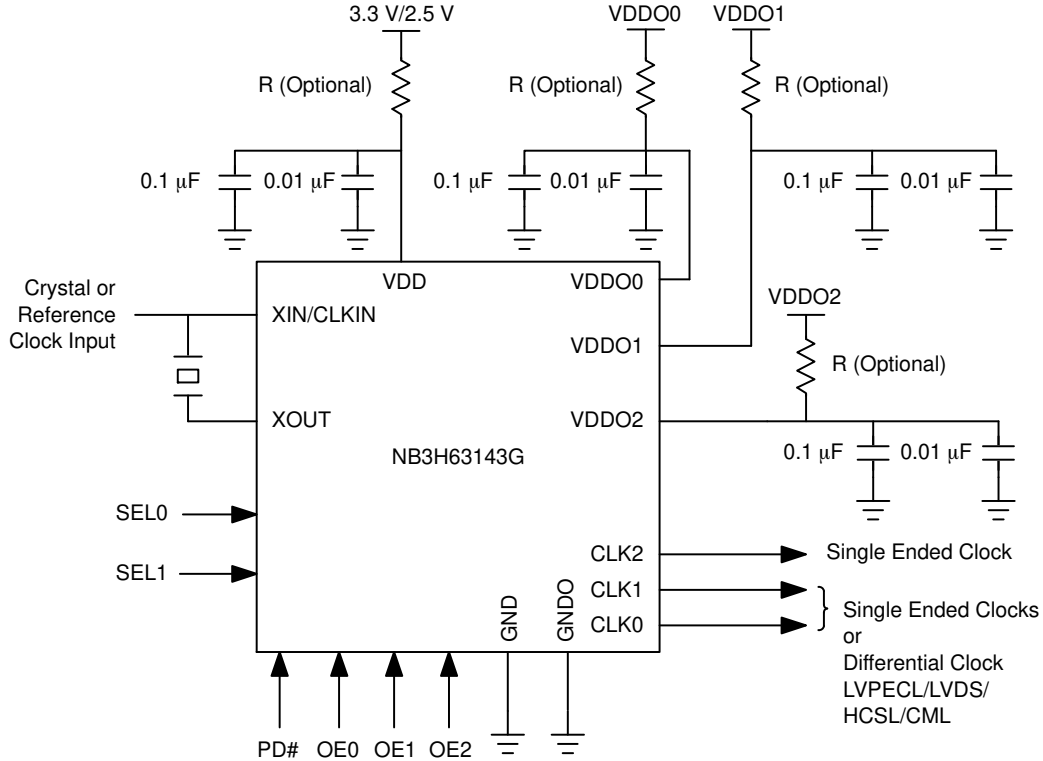

Figure 3. Power Supply and Output Supply Noise Suppression

### Power Supply

#### Device Supply

The NB3H63143G is designed to work with a 3.3 V/2.5 V VDD power supply. For VDD operation of 1.8 V, refer to the NB3V63143G datasheet. In order to suppress power supply noise it is recommended to connect decoupling capacitors of 0.1  $\mu$ F and 0.01  $\mu$ F close to the VDD pin as shown in Figure 3.

#### Output Power Supply

Each output CLK[2:0] has a separate output power supply VDDO[2:0] pin to control its output voltage. The output

power supply can be as high as VDD. It can be as low as 2.5 V for clock output types LVPECL/CML and as low as 1.8 V if using other clock output types. This feature removes the need for external voltage converters for each of the outputs thus reducing component count, saving board space and facilitating board design. In order to suppress power supply noise it is recommended to connect decoupling capacitors of 0.1  $\mu$ F and 0.01  $\mu$ F close to each VDDO pin as shown in Figure 3.

**Clock Input**

**Input Frequency**

The clock input block can be programmed to use a fundamental mode crystal from 3 MHz to 50 MHz or a single ended reference clock source from 3 MHz to 200 MHz. When using output frequency modulation for EMI reduction, for optimal performance, it is recommended to use crystals with a frequency greater than 6.75 MHz as input. Crystals with ESR values of up to 150 Ω are supported. While using a crystal as input, it is important to set crystal load capacitor values correctly to achieve good performance.

**Programmable Crystal Load Capacitors**

The provision of internal programmable crystal load capacitors eliminates the necessity of external load capacitors for standard crystals. The internal load capacitors can be programmed to any value between 4.36 pF and 20.39 pF with a step size of 0.05 pF. Refer to Table 5 for recommended maximum load capacitor values for stable operation. There are three modes of loading the crystal – with internal chip capacitors only, with external capacitors only or with the both internal and external capacitors. Check with the crystal vendor’s load capacitance specification for setting of the internal load capacitors. The minimum value of 4.36 pF internal load capacitor need to be considered while selecting external capacitor value. The internal load capacitors will be bypassed when using an external reference clock.

**Automatic Gain Control (AGC)**

The Automatic Gain Control (AGC) feature adjusts the gain to the input clock based on its signal strength to

maintain a good quality input clock signal level. This feature takes care of low clock swings fed from external reference clocks and ensures proper device operation. It also enables maximum compatibility with crystals from different manufacturers, processes, quality and performance. AGC also takes care of power dissipation in the crystal; avoids overdriving the crystal and thus extending the crystal life. In order to calculate the AGC gain accurately and avoid increasing the jitter on the output clocks, the user needs to provide the crystal load capacitance as well as other crystal parameters like ESR and shunt capacitance (C0).

**Programmable Clock Outputs**

**Output Type and Frequency**

The NB3H63143G provides three independent single ended LVCMOS/LVTTL outputs, or one single ended LVCMOS/LVTTL output and one LVPECL/LVDS/HCSL/CML differential output. The device supports any single ended output or differential output frequency from 8 kHz up to 200 MHz with or without frequency modulation. All outputs have individual output enable pins (refer to the Output Enable/Disable section on page 7). It should be noted that certain combinations of output frequencies and spread spectrum configurations may not be recommended for optimal and stable operation.

For differential clocking, CLK0 and CLK1 can be configured as LVPECL, LVDS, HCSL or CML. While using differential signaling format at the output, it is required to use only VDDO1 as output supply and use only the OE1 pin for the output enable function. (refer to the Application Schematic in Figure 4). When all 3 outputs are single ended, VDDO0 and OE0 have normal functionality.

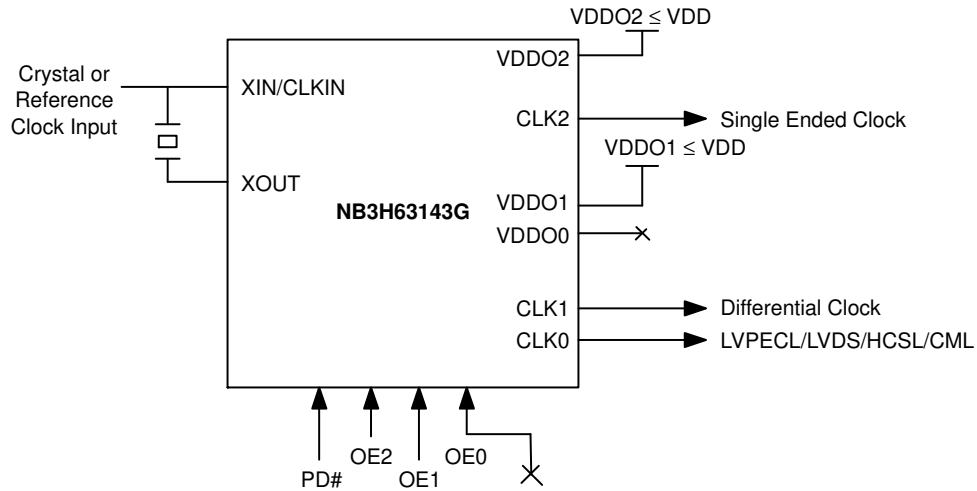

**Figure 4. Application Setup for Differential Output Configuration**

**Programmable Output Drive**

The drive strength or output current of each of the LVCMOS clock outputs is programmable independently. For each VDDO supply voltage, four distinct levels of LVCMOS output drive strengths can be selected as mentioned in DC Electrical Characteristics. This feature

provides further load drive and signal conditioning as per the application requirement.

**PLL BYPASS Mode**

PLL Bypass mode can be used to buffer the input clock on any of the outputs or all of the outputs. Any of the clock outputs can be programmed to generate a copy of the input clock.

**Output Inversion**

All output clocks of the NB3H63143G can be phase inverted relative to each other. This feature can also be used in conjunction with the PLL BYPASS mode.

**Spread Spectrum Frequency Modulation**

Spread spectrum is a technique using frequency modulation to achieve lower peak electromagnetic interference (EMI). It is an elegant solution compared to techniques of filtering and shielding. The NB3H63143G

modulates the output of its PLL in order to “spread” the bandwidth of the synthesized clock, decreasing the peak amplitude at the center frequency and at the frequency’s harmonics. This results in significantly lower system EMI compared to the typical narrow band signal produced by oscillators and most clock generators. Lowering EMI by increasing a signal’s bandwidth is called ‘spread spectrum modulation’.

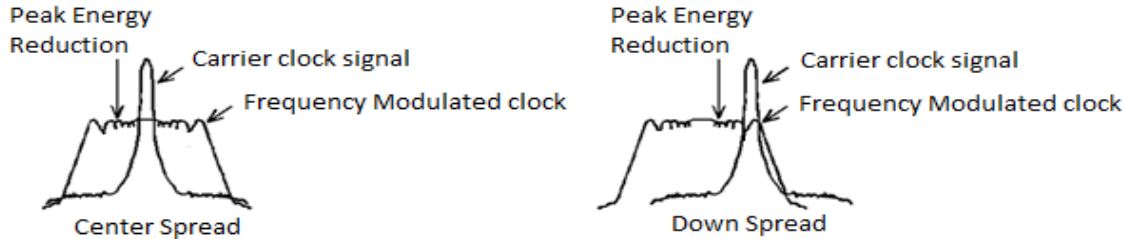

**Figure 5. Frequency Modulation or Spread Spectrum Clock for EMI Reduction**

The outputs of the NB3H63143G can be programmed to have either center spread from  $\pm 0.125\%$  to  $\pm 3\%$  or down spread from  $-0.25\%$  to  $-4\%$ . The programmable step size for spread spectrum deviation is  $0.125\%$  for center spread and  $0.25\%$  for down spread respectively. Additionally, the frequency modulation rate is also programmable. Frequency modulation from 30 kHz to 130 kHz can be selected. Spread spectrum, when on, applies to all the outputs of the device but not to output clocks that use the PLL bypass feature. There exists a tradeoff between the input clock frequency and the desired spread spectrum profile. For certain combinations of input frequency and modulation rate, the device operation could be unstable and should be avoided. For spread spectrum applications, the following limits are recommended:

$F_{in} (\text{Min}) = 6.75 \text{ MHz}$

$F_{mod} (\text{range}) = 30 \text{ kHz to } 130 \text{ kHz}$

$F_{mod} (\text{Max}) = F_{in} / 225$

For any input frequency selected, the above limits must be observed for a good spread spectrum profile.

For example, the minimum recommended reference frequency for a modulation rate of 30 kHz would be  $30 \text{ kHz} * 225 = 6.75 \text{ MHz}$ . For 27 MHz, the maximum recommended modulation rate would be  $27 \text{ MHz} / 225 = 120 \text{ kHz}$

**Control Inputs**

**Configuration Space Selection**

The SEL[1:0] pins are used to select one of the pre-programmed configurations statically or dynamically while the device is powered on. These pins are 2-level LVCMOS/LVTTL. Up to four configurations can be stored in the memory space of the device. Clock outputs can be independently enabled or disabled through the configuration space. To have a given clock output enabled, it must be enabled in both the configuration space and through its respective output enable pin.

The PLL re-locking and stabilization time must be taken into consideration when dynamically changing the configurations. Table 6 shows an example of four configurations.

**Table 6. EXAMPLE CONFIGURATION SPACE SETTINGS**

Configuration Selection	Input Frequency	Output Frequency	VDD	VDDO	SS%	SS Mod Rate	Output Drive	Output Inversion	Output Enable	PLL Bypass	Notes
I	25 MHz	CLK0=100 MHz CLK1=8 kHz CLK2=25 MHz	3.3 V	VDDO0=2.5 V VDDO1=1.8 V VDDO2=1.8 V	-0.5%	110 kHz	CLK0=12mA CLK1=8mA CLK2=4mA	CLK0=N CLK1=N CLK2=Y	CLK0=Y CLK1=Y CLK2=Y	CLK0=N CLK1=N CLK2=Y	CLK2 Ref clk
II	40 MHz	CLK0=125 MHz CLK1=40 MHz CLK2=10 MHz	3.3 V	VDDO0=2.5 V VDDO1=1.8 V VDDO2=1.8 V	$\pm 0.25\%$	30 kHz	CLK0=4mA CLK1=4mA CLK2=4mA	CLK0=N CLK1=N CLK2=N	CLK0=Y CLK1=Y CLK2=Y	CLK0=N CLK1=Y CLK2=N	CLK1 Ref clk
III	100 MHz	CLK0=100 MHz CLK1=100 MHz CLK2=100 MHz	3.3 V	VDDO0=2.5 V VDDO1=1.8 V VDDO2=1.8 V	No SS	NA	CLK0=12mA CLK1=8mA CLK2=4mA	CLK0=N CLK1=Y CLK2=Y	CLK0=Y CLK1=Y CLK2=Y	CLK0=Y CLK1=Y CLK2=Y	All Three Outputs are Ref clks
IV	25 MHz	CLK0=100 MHz CLK1=100 MHz CLK2=48 MHz	3.3 V	VDDO0=NA VDDO1=2.5 V VDDO2=3.3 V	-1%	100 kHz	CLK2=16mA	CLK0=NA CLK1=NA CLK2=N	CLK0=NA CLK1=Y CLK2=Y	CLK0=NA CLK1=N CLK2=N	CLK[1:0] is Differential Output

# NB3H63143G

## Output Enable/Disable

Output Enable pins (OE[2:0]) are LVCMOS/LVTTL input pins that individually enable or disable the outputs CLK[2:0] respectively. These inputs only disable the output buffers thus not affecting the rest of the blocks on the device. When using a differential output, only the OE1 pin must be used to enable/disable the differential output (the OE0 pin will be ignored). The hardware OE pins have an effect only when the respective outputs are enabled in the configuration space. The output disable state can be set to high impedance (Hi-Z) or Low.

## Power Down

Power saving mode can be activated through the power down PD# input pin. This input is an LVCMOS/LVTTL active Low Master Reset that disables the device and sets the outputs Low. By default it has an internal pull-down resistor.

The device functions are disabled by default and when the PD# pin is pulled high the device functions are activated.

## Default Device State

The NB3H63143G parts shipped from ON Semiconductor are blank, with no inputs/outputs programmed. The parts need to be programmed by the field sales or by a distributor or by the users themselves before they can be used. Programmable clock software downloadable from the ON Semiconductor website can be used along with the programming kit to achieve this purpose. For mass production, parts can be factory programmed with a customer qualified configuration and sourced from ON Semiconductor as a dash part number (Eg. NB3H63143G-01).

**Table 7. ATTRIBUTES**

Characteristic	Value
ESD Protection – Human Body Model	2 kV
Internal Input Default State Pull Up/Down Resistor	50 kΩ
Moisture Sensitivity, Indefinite Time Out of Dry Pack (Note 1)	MSL1
Flammability Rating – Oxygen Index: 28 to 34	UL 94 V-0 @ 0.125in
Transistor Count	130k
Meets or Exceeds JEDEC Spec EIA/JESD78 IC Latchup Test	

1. For additional information, see Application Note [AND8003/D](#).

## ABSOLUTE MAXIMUM RATINGS (Note 2)

Symbol	Parameter	Rating	Unit
VDD	Positive Power Supply with Respect to Ground	-0.5 to +4.6	V
V <sub>I</sub>	Input Voltage with Respect to Chip Ground	-0.5 to VDD + 0.5	V
T <sub>A</sub>	Operating Ambient Temperature Range (Industrial Grade)	-40 to +85	°C
T <sub>STG</sub>	Storage Temperature	-65 to +150	°C
T <sub>SOL</sub>	Max. Soldering Temperature (10 sec)	265	°C
θ <sub>JA</sub>	Thermal Resistance (Junction-to-Ambient) (Note 3) 0 lfpm 500 lfpm	32.3 24.22	°C/W °C/W
θ <sub>JC</sub>	Thermal Resistance (Junction-to-Case)	3.6	°C/W
T <sub>J</sub>	Junction Temperature	125	°C

Stresses exceeding those listed in the Maximum Ratings table may damage the device. If any of these limits are exceeded, device functionality should not be assumed, damage may occur and reliability may be affected.

- Maximum ratings applied to the device are individual stress limit values (not normal operating conditions) and not valid simultaneously. If stress limits are exceeded device functional operation is not implied, damage may occur and reliability may be affected.
- JEDEC standard multilayer board – 2S2P (2 signal, 2 power). JESD51.7 type board. Back side Copper heat spreader area 100 sqmm, 2 oz (0.070mm) copper thickness.



# NB3H63143G

## RECOMMENDED OPERATING CONDITIONS

Symbol	Parameter	Condition	Min	Typ	Max	Unit
VDD	Core Power Supply Voltage	3.3 V operation 2.5 V operation	2.97 2.25	3.3 2.5	3.63 2.75	V
VDDO[2:0]	Output Power Supply Voltage (Note 4)	3.3 V operation 2.5 V operation 1.8 V operation	2.97 2.25 1.7	3.3 2.5 1.8	3.63 2.75 1.9	V
CL	Clock output load capacitance for LVCMOS / LVTTTL clock	f <sub>out</sub> < 100 MHz f <sub>out</sub> ≥ 100 MHz			15 5	pF
fc <sub>lkin</sub>	Crystal Input Frequency Reference Clock Frequency	Fundamental Crystal Single ended clock input	3 3		50 200	MHz
C <sub>X</sub>	Xin / Xout pin stray capacitance	(Note 5)		4.5		pF
C <sub>XL</sub>	Crystal load capacitance	(Note 6)		10		pF
ESR	Crystal ESR				150	Ω

Functional operation above the stresses listed in the Recommended Operating Ranges is not implied. Extended exposure to stresses beyond the Recommended Operating Ranges limits may affect device reliability.

4. The output power supply voltage VDDO[2:0] must always be less than or equal to core power supply voltage VDD.

5. The Xin/ Xout pin stray capacitance needs to be subtracted from crystal load capacitance (along with PCB and trace capacitance) while selecting appropriate load for the crystal in order to get minimum ppm error.

6. Refer to XTAL parameters supplied by the vendor.

## DC ELECTRICAL CHARACTERISTICS

(V<sub>DD</sub> = 3.3 V ± 10%, 2.5 V ± 10%, VDDO[2:0] = 3.3 V ± 10%, 2.5 V ± 10%, 1.8 V ± 0.1V; GND = 0 V, T<sub>A</sub> = -40°C to 85°C, Note 7)

Symbol	Parameter	Condition	Min	Typ	Max	Unit
I <sub>DD_3.3 V</sub>	Power Supply Current for Core	Configuration Dependent. VDD = 3.3 V, T <sub>A</sub> = 25°C, XIN/CLKIN = 25 MHz (XTAL), CLK[0:2] = 100 MHz, 16 mA output drive		13		mA
I <sub>DD_2.5 V</sub>	Power Supply Current for Core	Configuration Dependent. VDD = 2.5 V, T <sub>A</sub> = 25°C, XIN/CLKIN = 25 MHz (XTAL), CLK[0:2] = 100 MHz, 12 mA output drive		13		mA
I <sub>PD</sub>	Power Down Supply Current	PD# is Low to Make All Outputs OFF			20	μA
V <sub>IH</sub>	Input HIGH Voltage	Pins XIN, SEL[1:0], OE[2:0]	0.65 V <sub>DD</sub>		V <sub>DD</sub>	V
		Pin PD#	0.85 V <sub>DD</sub>		V <sub>DD</sub>	
V <sub>IL</sub>	Input LOW Voltage	Pins XIN, SEL[1:0], OE[2:0]	0		0.35 V <sub>DD</sub>	V
		Pin PD#	0		0.15 V <sub>DD</sub>	
Z <sub>o</sub>	Nominal Output Impedance	Configuration Dependent. 12 mA Drive		22		Ω
R <sub>PUP/PD</sub>	Internal Pull Up/ Pull Down Resistor	VDD = 3.3 V VDD = 2.5 V		50 80		kΩ
C <sub>prog</sub>	Programmable Internal Crystal Load Capacitance	Configuration Dependent	4.36		20.39	pF
	Programmable Internal Crystal Load Capacitance Resolution			0.05		
C <sub>in</sub>	Input Capacitance	Pins PD#, SEL[1:0], OE[2:0]		4	6	pF

# NB3H63143G

## DC ELECTRICAL CHARACTERISTICS (continued)

( $V_{DD} = 3.3\text{ V} \pm 10\%$ ,  $2.5\text{ V} \pm 10\%$ ,  $V_{DDO}[2:0] = 3.3\text{ V} \pm 10\%$ ,  $2.5\text{ V} \pm 10\%$ ,  $1.8\text{ V} \pm 0.1\text{V}$ ;  $GND = 0\text{ V}$ ,  $T_A = -40^\circ\text{C}$  to  $85^\circ\text{C}$ , Note 7)

Symbol	Parameter	Condition	Min	Typ	Max	Unit
<b>LVC MOS/LVTTL OUTPUTS</b>						
$V_{OH}$	Output HIGH Voltage	$V_{DDO} = 3.3\text{ V}$ $I_{OH} = 4\text{ mA}$ $I_{OH} = 8\text{ mA}$ $I_{OH} = 12\text{ mA}$ $I_{OH} = 16\text{ mA}$  $V_{DDO} = 2.5\text{ V}$ $I_{OH} = 2\text{ mA}$ $I_{OH} = 4\text{ mA}$ $I_{OH} = 8\text{ mA}$ $I_{OH} = 12\text{ mA}$  $V_{DDO} = 1.8\text{ V}$ $I_{OH} = 1\text{ mA}$ $I_{OH} = 2\text{ mA}$ $I_{OH} = 4\text{ mA}$ $I_{OH} = 8\text{ mA}$	0.75xVDDO			V
$V_{OL}$	Output LOW Voltage	$V_{DDO} = 3.3\text{ V}$ $I_{OL} = 4\text{ mA}$ $I_{OL} = 8\text{ mA}$ $I_{OL} = 12\text{ mA}$ $I_{OL} = 16\text{ mA}$  $V_{DDO} = 2.5\text{ V}$ $I_{OL} = 2\text{ mA}$ $I_{OL} = 4\text{ mA}$ $I_{OL} = 8\text{ mA}$ $I_{OL} = 12\text{ mA}$  $V_{DDO} = 1.8\text{ V}$ $I_{OL} = 1\text{ mA}$ $I_{OL} = 2\text{ mA}$ $I_{OL} = 4\text{ mA}$ $I_{OL} = 8\text{ mA}$			0.25xVDDO	V
$I_{DDO\_LVC MOS}$	LVC MOS Output Supply Current	Configuration Dependent. $T_A = 25^\circ\text{C}$ , $CLK[0:2] = f_{out}$ in PLL bypass mode Measured on $V_{DDO} = 3.3\text{ V}$ $f_{out} = 33.33\text{ MHz}$ , $C_L = 5\text{ pF}$ $f_{out} = 100\text{ MHz}$ , $C_L = 5\text{ pF}$ $f_{out} = 200\text{ MHz}$ , $C_L = 5\text{ pF}$ Measured on $V_{DDO} = 2.5\text{ V}$ $f_{out} = 33.33\text{ MHz}$ , $C_L = 5\text{ pF}$ $f_{out} = 100\text{ MHz}$ , $C_L = 5\text{ pF}$ $f_{out} = 200\text{ MHz}$ , $C_L = 5\text{ pF}$ Measured on $V_{DDO} = 1.8\text{ V}$ $f_{out} = 33.33\text{ MHz}$ , $C_L = 5\text{ pF}$ $f_{out} = 100\text{ MHz}$ , $C_L = 5\text{ pF}$ $f_{out} = 200\text{ MHz}$ , $C_L = 5\text{ pF}$		6 16 32 4 12 24 3 8 16		mA

# NB3H63143G

## DC ELECTRICAL CHARACTERISTICS

( $V_{DD} = 3.3\text{ V} \pm 10\%$ ,  $2.5\text{ V} \pm 10\%$ ,  $V_{DDO}[2:0] = 3.3\text{ V} \pm 10\%$ ,  $2.5\text{ V} \pm 10\%$ ,  $1.8\text{ V} \pm 0.1\text{ V}$ ;  $GND = 0\text{ V}$ ,  $T_A = -40^\circ\text{C}$  to  $85^\circ\text{C}$ , Note 19)

Symbol	Parameter	Condition	Min	Typ	Max	Unit
--------	-----------	-----------	-----	-----	-----	------

### HCSL OUTPUTS (Note 8)

$V_{OH\_HCSL}$	Output HIGH Voltage (Note 9)	$V_{DDO} = 3.3\text{ V}, 2.5\text{ V}, 1.8\text{ V}$		700		mV
$V_{OL\_HCSL}$	Output Low Voltage (Note 9)	$V_{DDO} = 3.3\text{ V}, 2.5\text{ V}, 1.8\text{ V}$		0		mV
$V_{CROSS}$	Crossing Point Voltage (Notes 10 and 11)	$V_{DDO} = 3.3\text{ V}, 2.5\text{ V}$	250	350	450	mV
Delta $V_{cross}$	Change in Magnitude of $V_{cross}$ for HCSL Output (Notes 10 and 12)	$V_{DDO} = 3.3\text{ V}, 2.5\text{ V}$			150	mV
$I_{DDO\_HCSL}$	Measured on $V_{DDO0} = 2.5\text{ V}$ & $3.3\text{ V}$ with	$f_{out} = 100\text{ MHz}, CL = 2\text{ pF}$ $f_{out} = 200\text{ MHz}, CL = 2\text{ pF}$		22		mA

### LVDS OUTPUTS (Notes 10 and 13)

$V_{OD\_LVDS}$	Differential Output Voltage		250		450	mV
Delta $V_{OD\_LVDS}$	Change in Magnitude of $V_{OD}$ for Complementary Output States		0		25	mV
$V_{OS\_LVDS}$	Offset Voltage	$V_{DDO} = 2.5\text{ V} / 3.3\text{ V}$ $V_{DDO} = 1.8\text{ V}$		1200 900		mV
Delta $V_{OS\_LVDS}$	Change in Magnitude of $V_{OS}$ for Complementary Output States		0		25	mV
$V_{OH\_LVDS}$	Output HIGH Voltage (Note 14)	$V_{DDO} = 2.5\text{ V} / 3.3\text{ V}$ $V_{DDO} = 1.8\text{ V}$		1425 1100	1600 1250	mV
$V_{OL\_LVDS}$	Output LOW Voltage (Note 15)	$V_{DDO} = 2.5\text{ V} / 3.3\text{ V}$ $V_{DDO} = 1.8\text{ V}$	900 700	1075 800		mV
$I_{DDO\_LVDS}$		$f_{out} = 100\text{ MHz}$ $f_{out} = 200\text{ MHz}$		14		mA

### LVPECL OUTPUTS (Notes 16 and 17)

$V_{OH\_LVPECL}$	Output HIGH Voltage	$V_{DDO} = 2.5\text{ V}$ $V_{DDO} = 3.3\text{ V}$	$V_{DDO}-1450$	$V_{DDO}-900$ 1600 2400	$V_{DDO}-825$	mV
$V_{OL\_LVPECL}$	Output LOW Voltage	$V_{DDO} = 2.5\text{ V}$ $V_{DDO} = 3.3\text{ V}$	$V_{DDO}-2000$	$V_{DDO}-1700$ 800 1600	$V_{DDO}-1500$	mV
$V_{SWING}$	Peak-to-Peak output voltage swing		550	800	930	mV
$V_{cross}$	Crossover point voltage (Note 17)	$V_{DDO} = 2.5\text{ V}$ $V_{DDO} = 3.3\text{ V}$	270		380	
$I_{DDO\_LVPECL}$		$f_{out} = 100\text{ MHz}$ $f_{out} = 200\text{ MHz}$		25		mA

### CML OUTPUTS (Notes 17 and 18)

$V_{OH\_CML}$	Output HIGH Voltage	$V_{DDO} = 3.3\text{ V}$ $V_{DDO} = 2.5\text{ V}$	$V_{DDO} -60$ 3240 2440	$V_{DDO}-10$ 3290 2490	$V_{DDO}$ 3300 2500	mV
$V_{OL\_CML}$	Output LOW Voltage	$V_{DDO} = 3.3\text{ V}$ $V_{DDO} = 2.5\text{ V}$	$V_{DDO} -1100$ 2200 1400	$V_{DDO}-800$ 2500 1700	$V_{DDO} - 640$ 2660 1860	mV
$V_{OD\_CML}$	Differential Output Voltage Magnitude	$V_{DDO} = 3.3\text{ V}$ $V_{DDO} = 2.5\text{ V}$	640	780	1000	mV
$V_{cross}$	Crossover point voltage (Note 17)	$V_{DDO} = 3.3\text{ V}$ $V_{DDO} = 2.5\text{ V}$		$V_{DDO}-395$		

# NB3H63143G

## DC ELECTRICAL CHARACTERISTICS (continued)

( $V_{DD} = 3.3\text{ V} \pm 10\%$ ,  $2.5\text{ V} \pm 10\%$ ,  $V_{DDO}[2:0] = 3.3\text{ V} \pm 10\%$ ,  $2.5\text{ V} \pm 10\%$ ,  $1.8\text{ V} \pm 0.1\text{ V}$ ;  $GND = 0\text{ V}$ ,  $T_A = -40^\circ\text{C}$  to  $85^\circ\text{C}$ , Note 19)

Symbol	Parameter	Condition	Min	Typ	Max	Unit
--------	-----------	-----------	-----	-----	-----	------

### CML OUTPUTS (Notes 17 and 18)

$I_{DDO\_CML}$		$f_{out} = 100\text{ MHz}$ $f_{out} = 200\text{ MHz}$		5.0		mA
----------------	--	--	--	-----	--	----

Product parametric performance is indicated in the Electrical Characteristics for the listed test conditions, unless otherwise noted. Product performance may not be indicated by the Electrical Characteristics if operated under different conditions.

NOTE: Device will meet the specifications after thermal equilibrium has been established when mounted in a test socket or printed circuit board with maintained transverse airflow greater than 500 lfm.

- Measurement taken with single ended clock outputs terminated with test load capacitance of 5 pF and 15 pF and differential clock terminated with test load of 2 pF. See Figures 6, 7 and 12. Specifications for LVTTTL are valid for  $V_{DD}$  and  $V_{DDO}$  3.3 V only.
- Measurement taken with outputs terminated with  $R_S = 0\ \Omega$ ,  $R_L = 50\ \Omega$ , with test load capacitance of 2 pF. See Figure 8. Guaranteed by characterization.
- Measurement taken from single ended waveform.
- Measured at crossing point where the instantaneous voltage value of the rising edge of  $CLKx+$  equals the falling edge of  $CLKx-$ .
- Refers to the total variation from the lowest crossing point to the highest, regardless of which edge is crossing. Refers to all crossing points for this measurement.
- Defined as the total variation of all crossing voltage of rising  $CLKx+$  and falling  $CLKx-$ . This is maximum allowed variance in the VCROSS for any particular system.
- LVDS outputs require 100  $\Omega$  receiver termination resistor between differential pair. See Figure 9.
- $V_{OHmax} = V_{OSmax} + 1/2\ V_{ODmax}$ .
- $V_{OLmax} = V_{OSmin} - 1/2\ V_{ODmax}$ .
- LVPECL outputs loaded with 50  $\Omega$  to  $V_{DDO1} - 2.0\text{ V}$  for proper operation.
- Output parameters vary 1:1 with  $V_{DDO1}$ .
- CML outputs loaded with 50  $\Omega$  to  $V_{DDO1}$  for proper operation.
- Parameter guaranteed by design verification not tested in production.

## AC ELECTRICAL CHARACTERISTICS ( $V_{DD} = 3.3\text{ V} \pm 10\%$ , $2.5\text{ V} \pm 10\%$ , $V_{DDO}[2:0] = 3.3\text{ V} \pm 10\%$ , $2.5\text{ V} \pm 10\%$ , $1.8\text{ V} \pm 0.1\text{ V}$ ; $V_{DDO} \leq V_{DD}$ , $GND = 0\text{ V}$ , $T_A = -40^\circ\text{C}$ to $85^\circ\text{C}$ , Notes 19, 20, 23, 24 and 25)

Symbol	Parameter	Condition	Min	Typ	Max	Unit
$f_{out}$	Single Ended Output Frequency		0.008		200	MHz
$f_{MOD}$	Spread Spectrum Modulation Rate	$f_{clk} \geq 6.75\text{ MHz}$	30		130	kHz
SS	Percent Spread Spectrum (deviation from nominal frequency)	Down Spread	0		-4	%
		Center Spread	0		$\pm 3$	%
SSstep	Percent Spread Spectrum Change Step Size	Down Spread Step Size		0.25		%
		Center Spread Step Size		0.125		%
$SS_{RED}$	Spectral Reduction, 3rd harmonic	@SS = -0.5%, $f_{out} = 100\text{ MHz}$ , $f_{clk} = 25\text{ MHz}$ Crystal, RES BW at 30 kHz, All Output Types		-10		dB
$t_{PU}$	Stabilization Time from Power-up	$V_{DD} = 3.3\text{ V}$ , $2.5\text{ V}$ with Frequency Modulation ON		3.0		ms
$t_{PD}$	Stabilization Time from Power Down	Time from falling edge on PD pin to Tri-stated Outputs (Asynchronous)		3.0		ms
$t_{SEL}$	Stabilization Time from Change of Configuration	With Frequency Modulation ON		3.0		ms
$t_{OE1}$	Output Enable Time	Time from rising edge on OE pin to valid clock outputs (asynchronous)		$2/f_{out}$ (MHz)		$\mu\text{s}$
$t_{OE2}$	Output Disable Time	Time from falling edge on OE pin to valid clock outputs (asynchronous)		$2/f_{out}$ (MHz)		$\mu\text{s}$
Eppm	Synthesis Error	Configuration Dependent		0		ppm



# NB3H63143G

**AC ELECTRICAL CHARACTERISTICS** (continued) ( $V_{DD} = 3.3\text{ V} \pm 10\%$ ,  $2.5\text{ V} \pm 10\%$ ,  $V_{DDO}[2:0] = 3.3\text{ V} \pm 10\%$ ,  $2.5\text{ V} \pm 10\%$ ,  $1.8\text{ V} \pm 0.1\text{ V}$ ;  $V_{DDO} \leq V_{DD}$ ,  $GND = 0\text{ V}$ ,  $T_A = -40^\circ\text{C}$  to  $85^\circ\text{C}$ , Notes 19, 20, 23, 24 and 25)

Symbol	Parameter	Condition	Min	Typ	Max	Unit
--------	-----------	-----------	-----	-----	-----	------

**SINGLE ENDED OUTPUTS** ( $V_{DD} = 3.3\text{ V} \pm 10\%$ ,  $2.5\text{ V} \pm 10\%$ ,  $V_{DDO}[2:0] = 3.3\text{ V} \pm 10\%$ ,  $2.5\text{ V} \pm 10\%$ ,  $1.8\text{ V} \pm 0.1\text{V}$ ;  $V_{DDO} \leq V_{DD}$ ,  $T_A = -40$  to  $85^\circ\text{C}$ ) (Notes 19, 20, 23, 24 and 25)

$t_{\text{JITTER-3.3 V}}$	Period Jitter Peak-to-Peak	25 MHz xtal input, $f_{\text{out}} = 100\text{ MHz}$ , SS off, Configuration Dependent (Note 25, see Figure 14)		100		ps
	Cycle-Cycle Jitter	25 MHz xtal input, $f_{\text{out}} = 100\text{ MHz}$ , SS off, Configuration Dependent (Note 25, see Figure 14)		100		
$t_{\text{JITTER-2.5 V}}$	Period Jitter Peak-to-Peak	25 MHz xtal input, $f_{\text{out}} = 100\text{ MHz}$ , SS off, Configuration Dependent (Note 25, see Figure 14)		100		ps
	Cycle-Cycle Jitter	25 MHz xtal input, $f_{\text{out}} = 100\text{ MHz}$ , SS off, Configuration Dependent (Note 25, see Figure 14)		100		
$t_r / t_f 3.3\text{ V}$	Rise/Fall Time	Measured between 20% to 80% with 15 pF load, $f_{\text{out}} = 100\text{ MHz}$ , $V_{DD} = V_{DDO} = 3.3\text{ V}$ , Max Drive Min Drive		1 2		ns
$t_r / t_f 2.5\text{ V}$	Rise/Fall Time	Measured between 20% to 80% with 15 pF load, $f_{\text{out}} = 100\text{ MHz}$ , $V_{DD} = V_{DDO} = 2.5\text{ V}$ , Max Drive Min Drive		1 2		ns
$t_{\text{DC}}$	Output Clock Duty Cycle	$V_{DD} = 3.3\text{ V}, 2.5\text{ V}$ ; $V_{DDO} \leq V_{DD}$ Duty Cycle of Ref clock is 50% PLL Clock Reference Clock	45 40	50 50	55 60	%

**DIFFERENTIAL OUTPUT (CLK1, CLK0)** ( $V_{DD} = 3.3\text{ V} \pm 10\%$ ,  $2.5\text{ V} \pm 10\%$ ,  $V_{DDO}[2:0] = 3.3\text{ V} \pm 10\%$ ,  $2.5\text{ V} \pm 10\%$ ,  $1.8\text{ V} \pm 0.1\text{V}$ ;  $V_{DDO} \leq V_{DD}$ ,  $T_A = -40$  to  $85^\circ\text{C}$ ) (Notes 19, 20, 23, 24 and 25)

$t_{\text{JITTER-3.3 V}}$	Period Jitter Peak-to-Peak	Configuration Dependent. 25 MHz xtal input, $f_{\text{out}} = 100\text{ MHz}$ , SS off, CLK2 = OFF (Note 21, 23 and 25, see Figure 14)		100		ps
	Cycle-Cycle Jitter	Configuration Dependent. 25 MHz xtal input, $f_{\text{out}} = 100\text{ MHz}$ , SS off, CLK2 = OFF (Note 22, 23 and 25, see Figure 14)		100		
$t_{\text{JITTER-2.5 V}}$	Period Jitter Peak-to-Peak	Configuration Dependent. 25 MHz xtal input, $f_{\text{out}} = 100\text{ MHz}$ , SS off, CLK2 = OFF (Note 22 and 24, see Figure 9)		100		ps
	Cycle-Cycle Jitter	Configuration Dependent. 25 MHz xtal input, $f_{\text{out}} = 100\text{ MHz}$ , SS off, CLK2 = OFF (Note 22, 23 and 25, see Figure 14)		100		
$t_r 3.3\text{ V}$	Rise Time	Measured between 20% to 80%, $V_{DD} = 3.3\text{ V}$  LVPECL LVDS HCSL CML	175		700	ps
$t_r 2.5\text{ V}$	Rise Time	Measured between 20% to 80%, $V_{DD} = 2.5\text{ V}$  LVPECL LVDS HCSL CML	175		700	ps

# NB3H63143G

**AC ELECTRICAL CHARACTERISTICS** (continued) ( $V_{DD} = 3.3\text{ V} \pm 10\%$ ,  $2.5\text{ V} \pm 10\%$ ,  $V_{DDO}[2:0] = 3.3\text{ V} \pm 10\%$ ,  $2.5\text{ V} \pm 10\%$ ,  $1.8\text{ V} \pm 0.1\text{ V}$ ;  $V_{DDO} \leq V_{DD}$ ,  $GND = 0\text{ V}$ ,  $T_A = -40^\circ\text{C}$  to  $85^\circ\text{C}$ , Notes 19, 20, 23, 24 and 25)

Symbol	Parameter	Condition	Min	Typ	Max	Unit
--------	-----------	-----------	-----	-----	-----	------

**DIFFERENTIAL OUTPUT (CLK1, CLK0)** ( $V_{DD} = 3.3\text{ V} \pm 10\%$ ,  $2.5\text{ V} \pm 10\%$ ,  $V_{DDO}[2:0] = 3.3\text{ V} \pm 10\%$ ,  $2.5\text{ V} \pm 10\%$ ,  $1.8\text{ V} \pm 0.1\text{ V}$ ;  $V_{DDO} \leq V_{DD}$ ,  $T_A = -40$  to  $85^\circ\text{C}$ ) (Notes 19, 20, 23, 24 and 25)

$t_{f,3.3\text{ V}}$	Fall Time	Measured between 20% to 80% with 2 pF load, $V_{DD} = 3.3\text{ V}$  LVPECL LVDS HCSL CML	175		700	ps
$t_{f,2.5\text{ V}}$	Fall Time	Measured between 20% to 80% with 2 pF load, $V_{DD} = 2.5\text{ V}$  LVPECL LVDS HCSL CML	175		700	ps
$t_{DC}$	Output Clock Duty Cycle	$V_{DD} = 3.3\text{ V}, 2.5\text{ V}$ ; Duty Cycle of Ref clock is 50% PLL Clock Reference Clock	45 40	50 50	55 60	%

Product parametric performance is indicated in the Electrical Characteristics for the listed test conditions, unless otherwise noted. Product performance may not be indicated by the Electrical Characteristics if operated under different conditions.

NOTE: Device will meet the specifications after thermal equilibrium has been established when mounted in a test socket or printed circuit board with maintained transverse airflow greater than 500 lfpm.

- 20. Measurement taken from single ended clock terminated with test load capacitance of 5 pF and 15 pF and differential clock terminated with test load of 2 pF. See Figures 6, 7 and 12.
- 21. Measurement taken from single ended waveform.
- 22. Measurement taken from differential waveform.
- 23. AC performance parameters like jitter change based on the output frequency, spread selection, power supply and loading conditions of the output. For application specific AC performance parameters, please contact ON Semiconductor.
- 24. Measured at  $f_{out} = 100\text{ MHz}$ , No Frequency Modulation,  $f_{clkIn} = 25\text{ MHz}$  fundamental mode crystal and output termination as described in Parameter Measurement Test Circuits
- 25. Period jitter Sampled with 10000 cycles, Cycle-cycle jitter sampled with 1000 cycles. Jitter measurement may vary. Actual jitter is dependent on Input jitter and edge rate, number of active outputs, inputs and output frequencies, supply voltage, temperature, and output load.

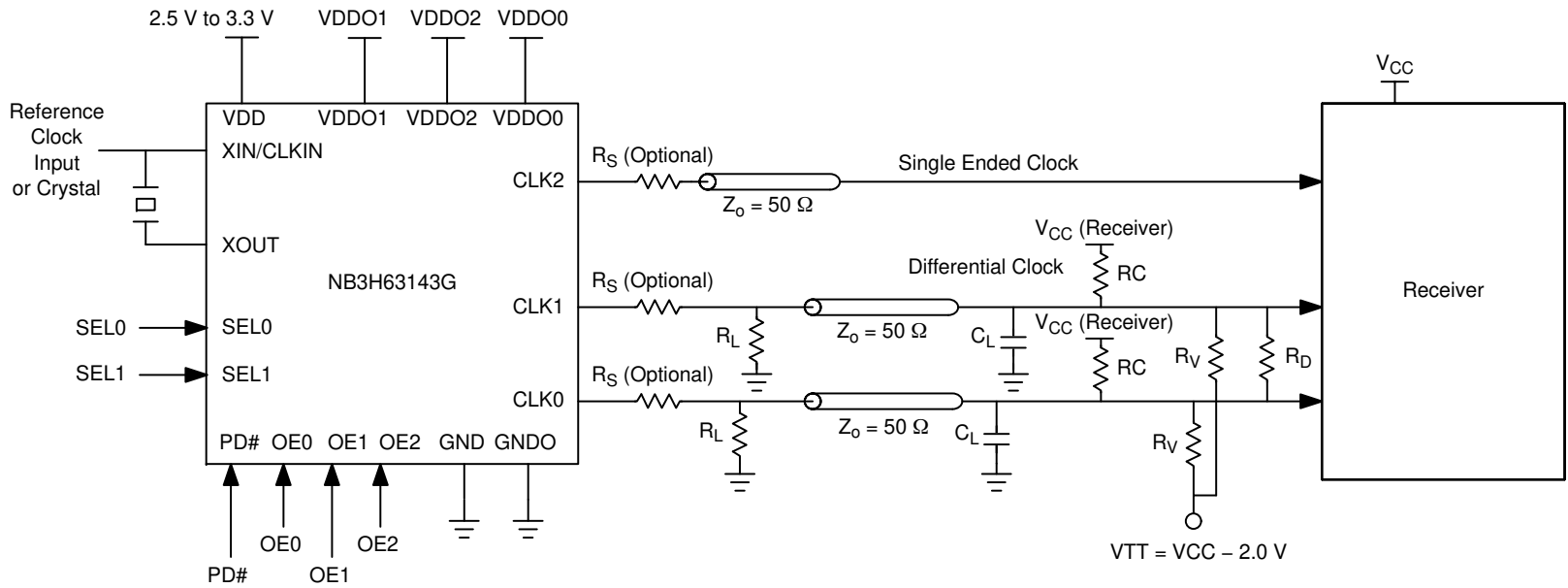

Figure 6. Typical Termination for Single Ended and Differential Signaling Device Load

	Single Ended Signal		Differential Signal	
	MIN	MAX	MIN	MAX
VDD	2.5 V	3.3 V	2.5 V	3.3 V
VDDO2	1.8 V	VDD	-	-
VDDO1	1.8 V	VDD	2.5 V (LVPECL/CML) 1.8 V (LVDS/HCSL)	VDD
VDDO0	1.8 V	VDD	-	-

Differential Clock Termination						
Signaling Type	$R_S$	$R_D$	$R_L$	$C_L$	$R_C$	$R_V$
LVCMOS	Optional	Open	Open	Open	Open	Open
LVPECL	Optional	Open	Open	Open	Open	50
LVDS	Optional	100	Open	Open	Open	Open
HCSL	Optional	Open	50	2 pF	Open	Open
CML	Optional	Open	Open	Open	50	Open

- 26. Receiver VCC must be at same supply potential as VDDO1 for differential clock outputs.
- 27. All resistor values are in ohms.
- 28. VDDO [2:0] <= VDD always

PARAMETER MEASUREMENT TEST CIRCUITS

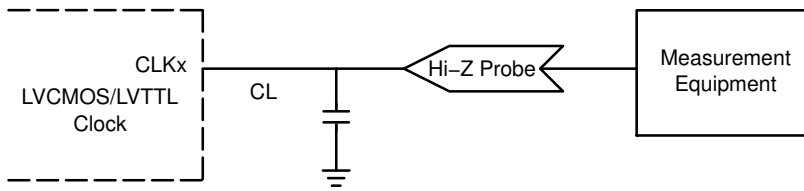

Figure 7. LVC MOS/LVTTL Parameter Measurement

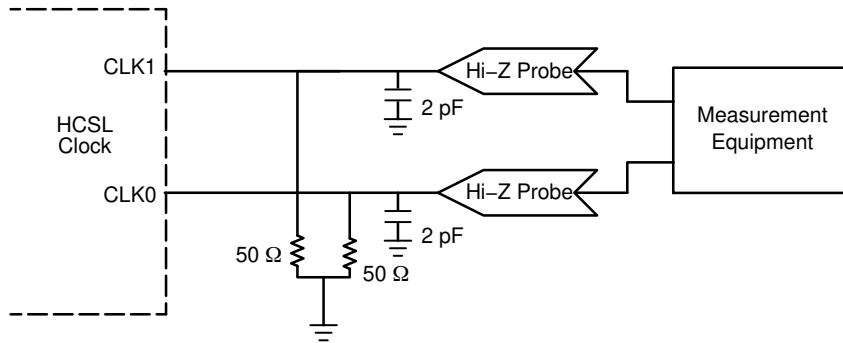

Figure 8. HCSL Parameter Measurement

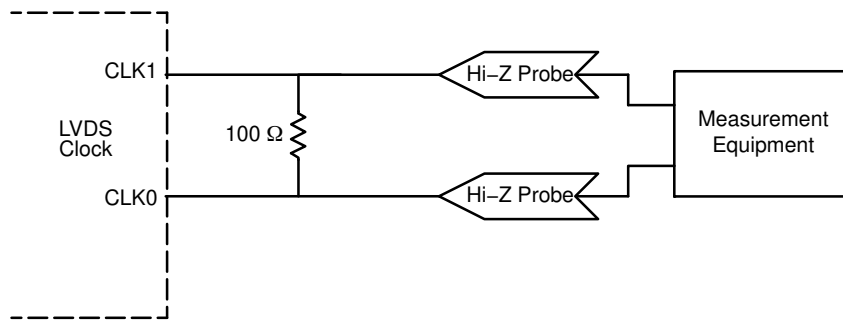

Figure 9. LVDS Parameter Measurement

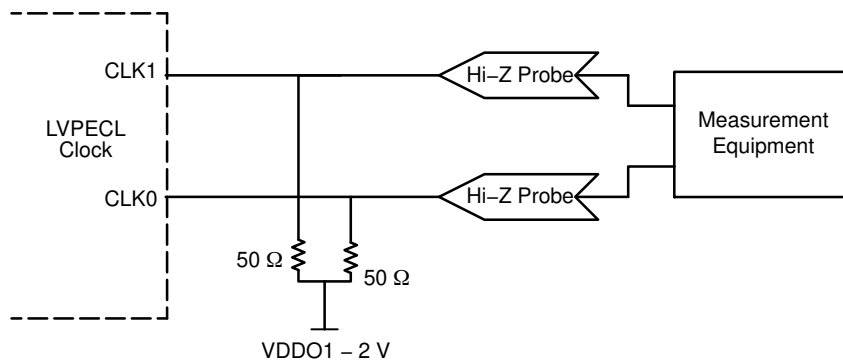

Figure 10. LVPECL Parameter Measurement



# NB3H63143G

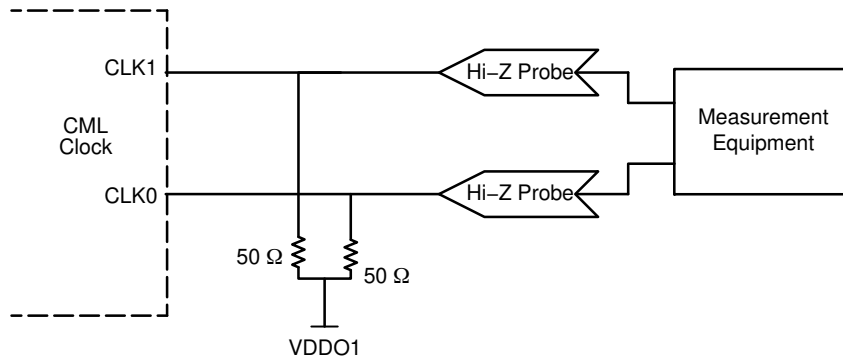

Figure 11. CML Parameter Measurement

## TIMING MEASUREMENT DEFINITIONS

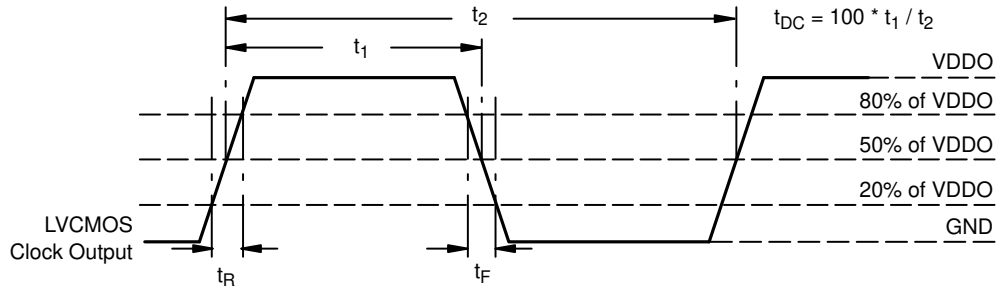

Figure 12. LVC MOS Measurement for AC Parameters

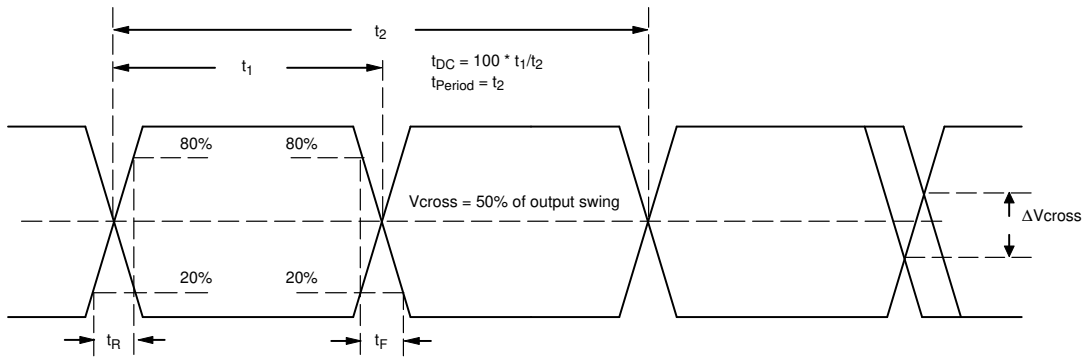
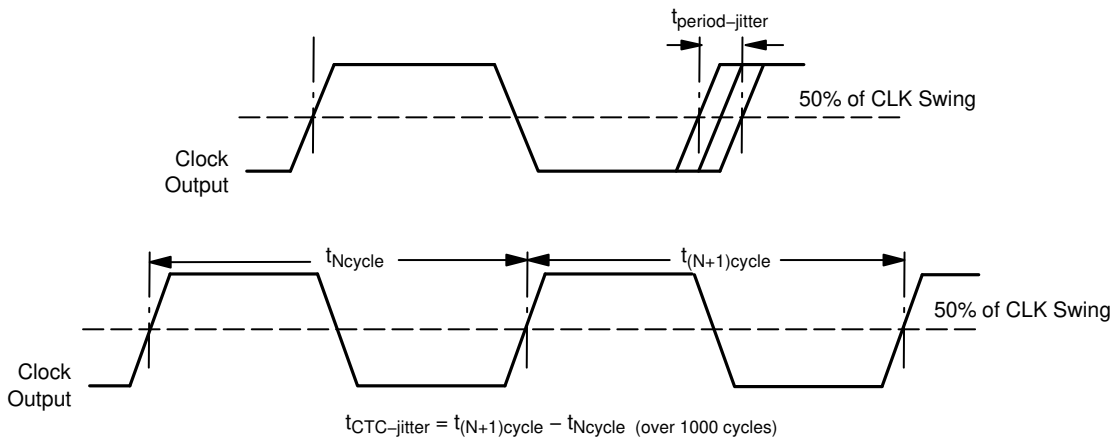
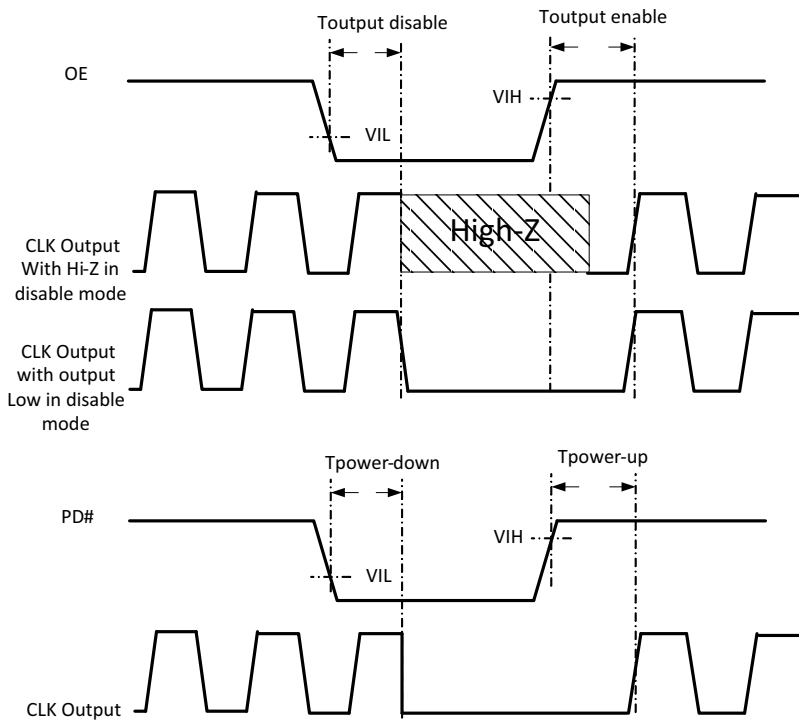

Figure 13. Differential Measurement for AC Parameters

# NB3H63143G



**Figure 14. Period and Cycle–Cycle Jitter Measurement**



**Figure 15. Output Enable/ Disable and Power Down Functions**

APPLICATION GUIDELINES

**Crystal Input Interface**

Figure 16 shows the NB3H63143G device crystal oscillator interface using a typical parallel resonant fundamental mode crystal. A parallel crystal with loading capacitance  $C_L = 18 \text{ pF}$  would use  $C1 = 32 \text{ pF}$  and  $C2 = 32 \text{ pF}$  as nominal values, assuming  $4 \text{ pF}$  of stray capacitance per line.

$$C_L = (C1 + C_{stray})/2; C1 = C2$$

The frequency accuracy and duty cycle skew can be fine-tuned by adjusting the C1 and C2 values. For example, increasing the C1 and C2 values will reduce the operational frequency. Note R1 is optional and may be  $0 \Omega$ .

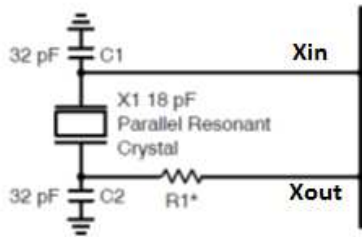

Figure 16. Crystal Interface Loading

**Output Interface and Terminations**

The NB3H63143G consists of a unique Multi Standard Output Driver to support LVCMOS/LVTTL, LVPECL, LVDS, HCSL and CML standards. Termination techniques required for each of these standards are different to ensure proper functionality. From the device it is possible to switch off one output driver and turn on another output driver using the SEL[1:0] pins as part of the Configuration Settings. The required termination changes must be considered and taken care of by the system designer.

**LVC MOS/LVTTL Interface**

LVC MOS/LVTTL output swings rail-to-rail up to VDDO supply (minimum 1.8 V) and can drive up to 15 pF load at higher drive strengths. The output buffer's drive is programmable up to four steps, though the drive current will depend on the step setting as well as the VDDO supply voltage. (See Figure 17 and Table 8). Drive strength must be configured high for driving higher loads. The slew rate of the clock signal increases with higher output current drive for the same load. The software lets the user choose the load drive current value per LVC MOS/LVTTL output based on the VDDO supply selected.

Table 8. LVC MOS/LVTTL DRIVE LEVEL SETTINGS

VDDO Supply	Load Current Setting 3 Max Load Current	Load Current Setting 2	Load Current Setting 1	Load Current Setting 0 Min Load Current
3.3 V	16 mA	12 mA	8 mA	4 mA
2.5 V	12 mA	8 mA	4 mA	2 mA
1.8 V	8 mA	4 mA	2 mA	1 mA

The IDDO current consists of the static current component (varies with drive) and dynamic current component. For any VDDO, the IDDO dynamic current range per LVC MOS output can be approximated by the following:

$$IDDO = f_{out} * C_{load} * VDDO$$

$C_{load}$  includes the load capacitor connected to the output, the pin capacitor posed by the output pin (typically 5 pF) and the cap load posed by the receiver input pin.  $C_{load} = (C_L + C_{pin} + C_{in})$

An optional series resistor  $R_s$  can be connected at the output for impedance matching, to limit the overshoots and ringings.

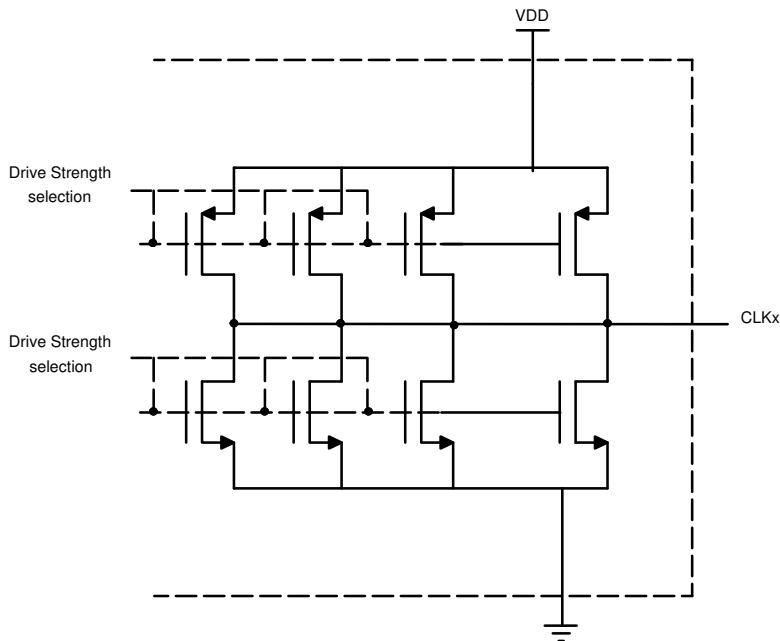

Figure 17. Simplified LVCMOS Output Structure

**LVDS Interface**

Differential signaling like LVDS has inherent advantage of common mode noise rejection and low noise emission, and thus a popular choice for clock distribution in systems. TIA/EIA-644 or LVDS is a standard differential, point-to-point bus topology that supports fast switching speeds and has the benefit of low power consumption. The driver consists of a low swing differential with constant current of 3.5 mA through the differential pair, and generates switching output voltage across a 100 Ω

terminating resistor (externally connected or internal to the receiver). Power dissipation in LVDS standard  $((3.5 \text{ mA})^2 \times 100 \text{ } \Omega = 1.2 \text{ mW})$  is thus much lower than other differential signalling standards.

A fan-out LVDS buffer (like ON Semiconductor’s NB6N1xS and NB6L1xS) can be used as an extension to provide clock signal to multiple LVDS receivers to drive multiple point-to-point links to receiving node.

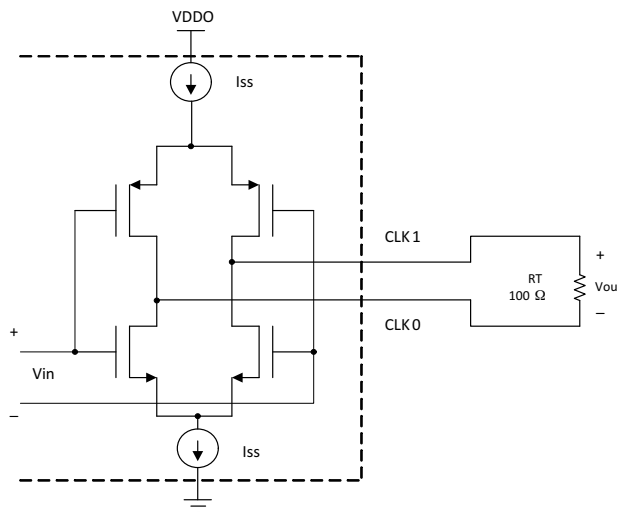

Figure 18. Simplified LVDS Output Structure with Termination



**LVPECL Interface**

The LVPECL driver is designed to drive a 50 Ω transmission line from a constant current differential and a low impedance emitter follower. On the NB3H63143G, this differential standard is supported for VDDO supply voltage of 2.5 V and above. In the system, the clock receiver must be referenced at the same supply voltage as VDDO for reliable functionality. The termination to receiver V<sub>CC</sub> - 2 V (1.3 V for a 3.3 V VDDO supply, and 0.5 V for a 2.5 V

VDDO supply) used in evaluation boards, is rarely used in system boards as it adds another power supply on the system board. Thus, Thevenin’s equivalent circuit (Figure 20) for this termination or a Y-type termination (Figure 21) is often used in systems. Termination techniques for LVPECL are detailed in the application note “Termination of ECL Devices with EF (Emitter Follower) OUTPUT Structure – AND8020”.

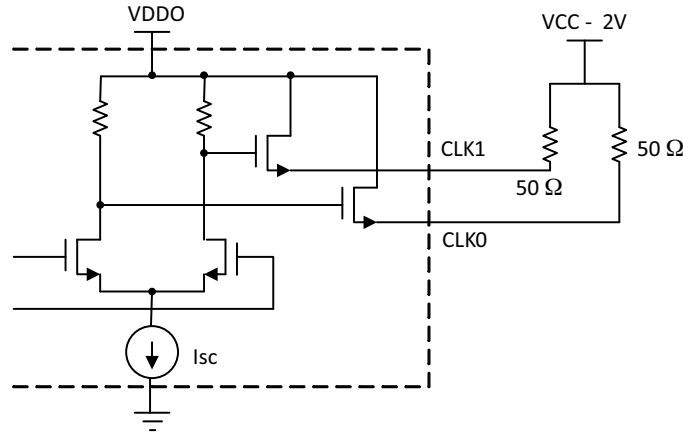

Figure 19. Simplified LVPECL Output Structure with Termination

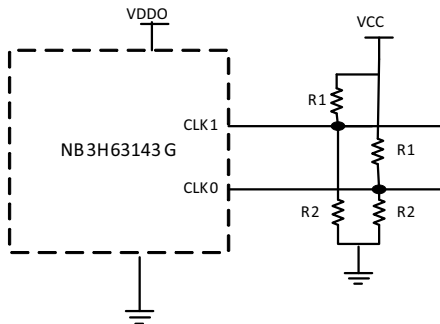

Figure 20. LVPECL Thevenin Termination

System Supply	Practical R2 (Ω)	Practical R1 (Ω)
2.5 V System	62(5%)	240(5%)
3.3 V system	82(5%)	130(5%)

Y-Termination	RT (Ω)
2.5 V System	50
3.3 V system	18

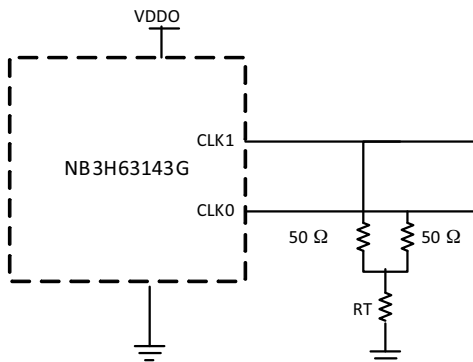

Figure 21. LVPECL Y-Termination

The termination should be placed as close to the receiver as possible to avoid unterminated stubs that can cause signal integrity issues.

**CML Interface**

A CML driver consists of an NMOS open drain constant current differential driving 16 mA current into a 50 Ω load terminated to the supply voltage at the receiver. This termination resistor can be external or internal to the receiver and needs to be as close as possible to the receiver. On the NB3H63143G, this differential standard is supported for VDDO supply voltage 2.5 V and above. The termination techniques used for a CML driver are detailed in application note “Termination and Interface of ON Semiconductor ECL Devices With CML (Current Mode Logic) OUTPUT Structure – AND8173”

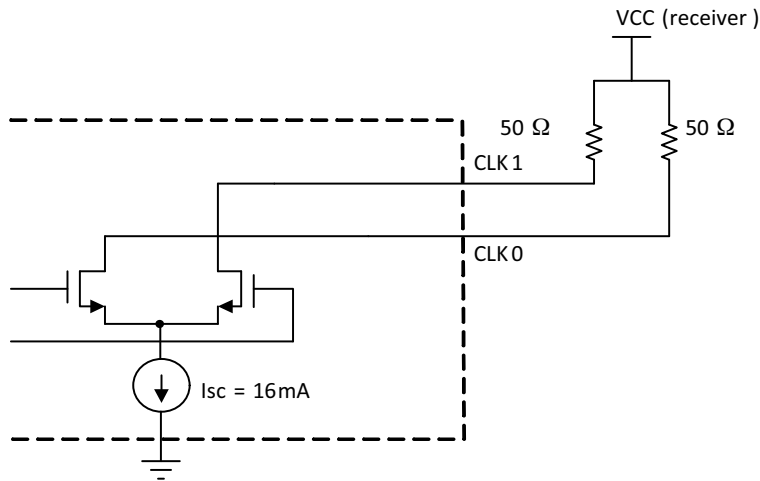

Figure 22. Simplified CML Output Structure with Termination

**HCSL Termination**

HCSL is a differential signaling standard commonly used in PCIe systems. The HCSL driver is typical 14.5 mA switched current open source output that needs a  $50\ \Omega$  termination resistor to ground near the source, and generates 725 mV of signal swing. A series resistor ( $10\ \Omega$  to  $33\ \Omega$ ) is optionally used to achieve impedance matching by limiting

overshoot and ringing due to the rapid rise of current from the output driver. The open source driver has high internal impedance; thus a series resistor up to  $33\ \Omega$  does not affect the signal integrity. This resistor can be avoided for low VDDO supply (1.8 V) of operation, unless impedance matching requires it.

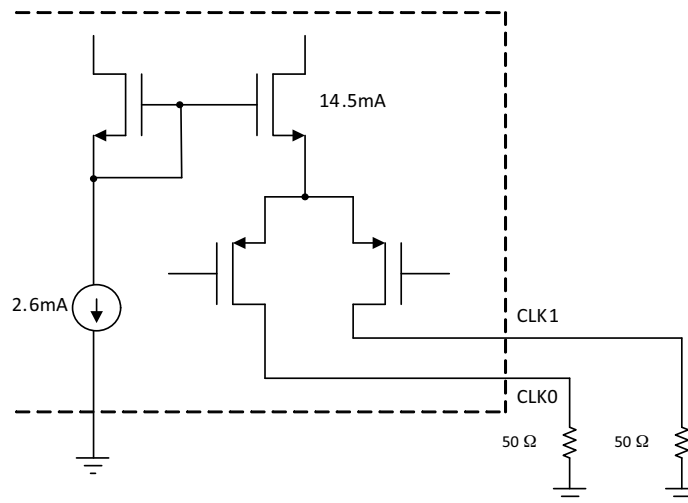

Figure 23. Simplified HCSL Output Structure with Termination

**Field Programming Kit and Software**

The NB3H63143G can be programmed by the user using the ‘Clock Cruiser Programmable Clock Kit’. This device uses the 16L daughter card on the hardware kit. To design a new clock, ‘Clock Cruiser Software’ is required to be installed from the ON Semiconductor website. The user manuals for the hardware kit Clock Cruiser Programmable Clock Kit and Clock Cruiser Software can be found following this link [www.onsemi.com](http://www.onsemi.com).

**Recommendation for Clock Performance**

Clock performance is specified in terms of Jitter in the time domain. Details and measurement techniques of

Cycle–cycle jitter, period jitter, TIE jitter and Phase Noise are explained in application note AND8459/D.

In order to have a good clock signal integrity for minimum data errors, it is necessary to reduce the signal reflections. The reflection coefficient can be zero only when the source impedance equals the load impedance. Reflections are based on signal transition time (slew rate) and due to impedance mismatch. Impedance matching with proper termination is required to reduce the signal reflections. The amplitude of overshoots is due to the difference in impedance and can be minimized by adding a series resistor ( $R_s$ ) near the output pin. Greater the difference in impedance, greater is the

amplitude of the overshoots and subsequent ripples. The ripple frequency is dependant on the signal travel time from the receiver to the source. Shorter traces results in higher ripple frequency, as the trace gets longer the travel time increases, reducing the ripple frequency. The ripple frequency is independent of signal frequency, and only depends on the trace length and the propagation delay. For eg. On an FR4 PCB with approximately 150 ps/inch of propagation rate on a 2 inch trace, the ripple frequency =  $1 / (150 \text{ ps} * 2 \text{ inch} * 5) = 666.6 \text{ MHz}$ ; [5 = number of times the signal travels, 1 trip to receiver plus 2 additional round trips].

PCB traces should be terminated when trace length  $\geq tr/f / (2 * t_{prate})$ ;  $tr/t = \text{rise/fall time of signal}$ ,  $t_{prate} = \text{propagation rate of trace}$ .

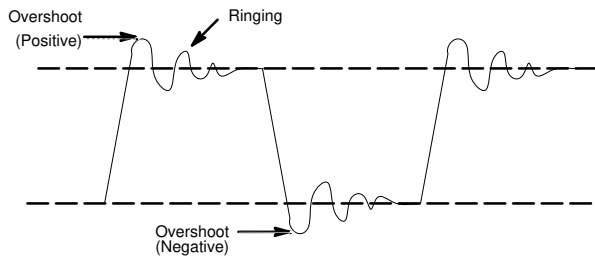

Figure 24. Signal Reflection Components

**PCB Design Recommendation**

For a clean clock signal waveform it is necessary to have a clean power supply for the device. The device must be isolated from system power supply noise. A 0.1  $\mu\text{F}$  and a 2.2  $\mu\text{F}$  decoupling capacitor should be mounted on the component side of the board as close to the VDD pin as possible. No vias should be used between the decoupling capacitor and VDD pin. The PCB trace to VDD pin and the ground via should be kept as thick and as short as possible. All the VDD pins should have decoupling capacitors.

Stacked power and ground planes on the PCB should be large. Signal traces should be on the top layer with minimum vias and discontinuities and should not cross the reference planes. The termination components must be placed near the source or the receiver. In an optimum layout all components are on the same side of the board, minimizing vias through other signal layers.

**Device Applications**

The NB3H63143G is targeted mainly for the Consumer market segment and can be used as per the examples below.

**Clock Generator**

Consumer applications like a Set top Box, have multiple sub-systems and standard interfaces and require multiple reference clock sources at various locations in the system. This part can function as a clock generating IC for such applications generating a reference clock for interfaces like USB, Ethernet, Audio/Video, ADSL, PCI etc.

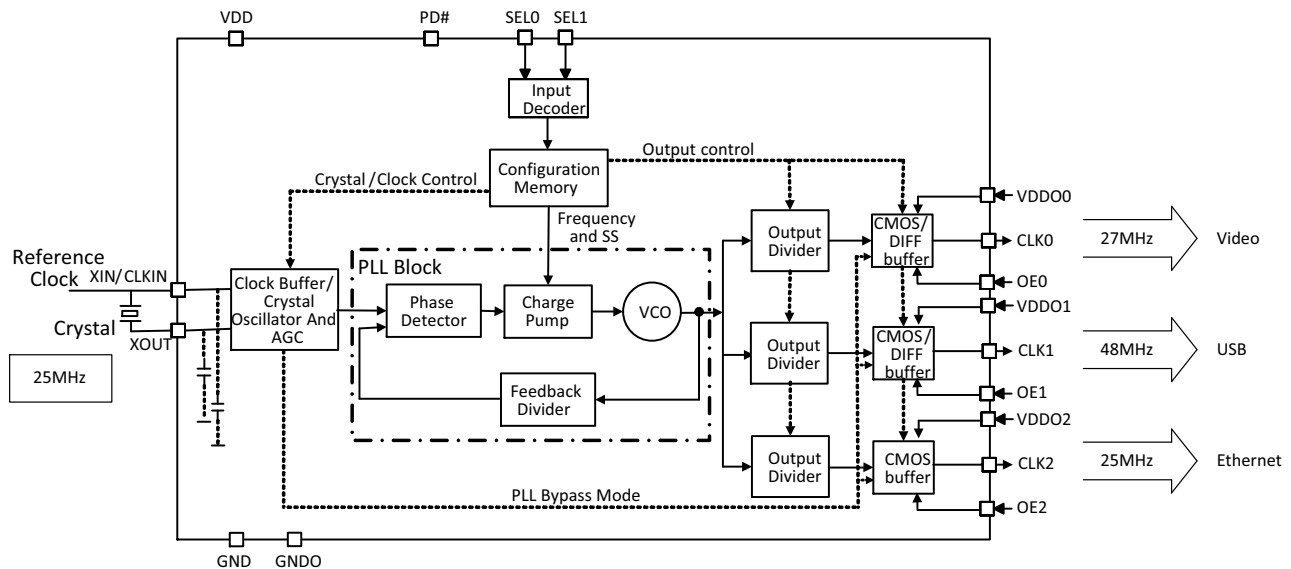

Figure 25. Application as Clock Generator

**Buffer and Logic/Level Translator**

The NB3H63143G is useful as a simple CMOS Buffer in PLL bypass mode. One or more outputs can use the PLL Bypass mode to generate the buffered outputs. If the PLL is configured to use spread spectrum, all outputs using PLL Bypass feature will not be subjected to the spread spectrum. The device can be simultaneously used as logic translator for

converting the LVCMOS input clock to LVPECL, LVDS, HCSL, CML, or LVCMOS (with different output voltage level).

For instance in applications like an LCD monitor, for converting the LVCMOS input clock to LVDS output.

# NB3H63143G

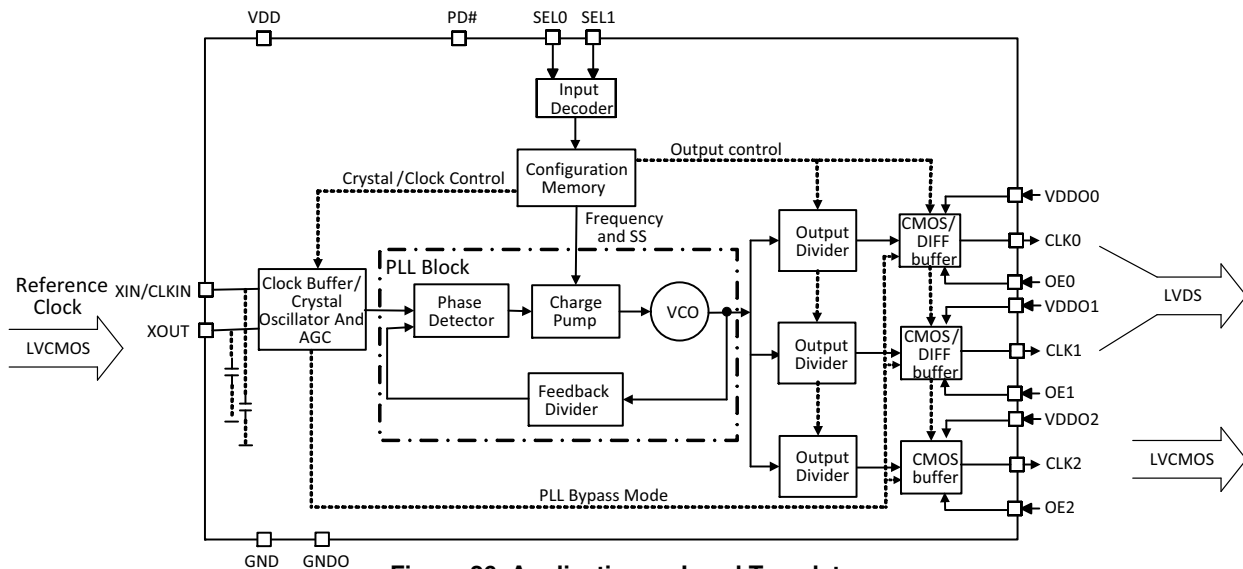

**Figure 26. Application as Level Translator**

NOTE: Since the device requirement is  $VDDO \leq VDD$ , LVC MOS signal level cannot be translated to a higher level of LVC MOS voltage.

## EMI Attenuator

Spread spectrum through frequency modulation technique enables the reduction of EMI radiated from the high frequency clock signals by spreading the spectral energy to the nearby frequencies. While using frequency modulation, the same selection is applied to all the PLL

clock outputs (not bypass outputs) even if they are at different frequencies. In Figure 27, CLK0 uses the PLL and hence is subjected to the spread spectrum modulation while CLK1 and CLK2 use the PLL Bypass mode and hence are not subjected to the spread spectrum modulation.

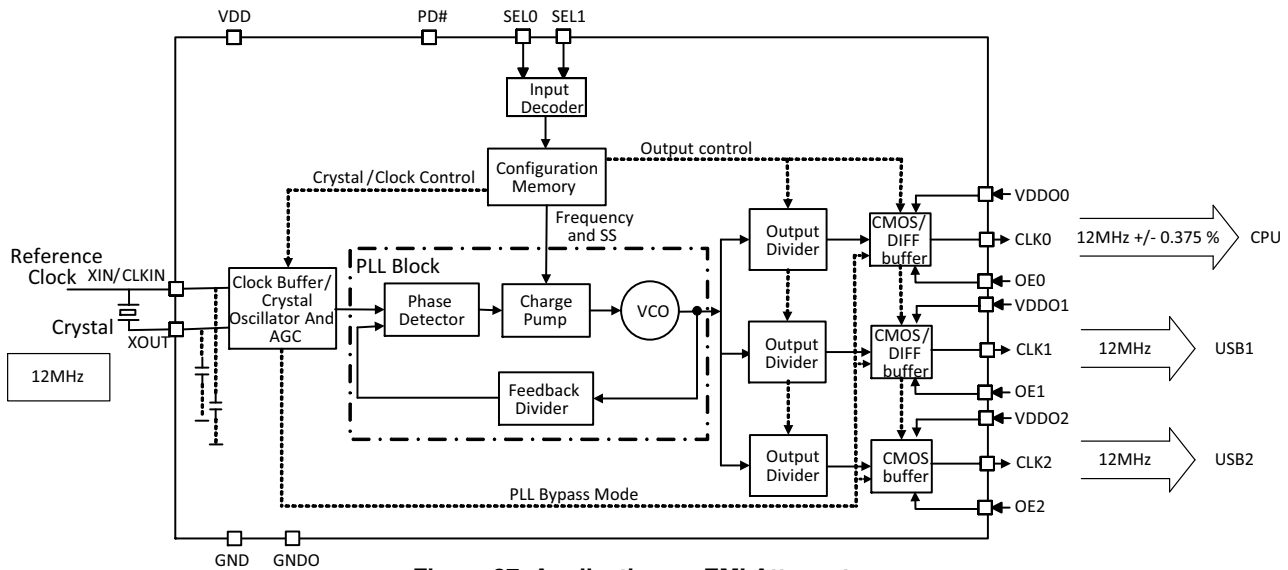

**Figure 27. Application as EMI Attenuator**

## ORDERING INFORMATION

Device	Case	Package	Type	Shipping†
NB3H63143G00MNR2G	485AE	QFN-16 (Pb-Free)	Blank Device	3000 / Tape & Reel
NB3H63143GxxMNR2G	485AE	QFN-16 (Pb-Free)	Factory Pre-programmed Device	3000 / Tape & Reel

†For information on tape and reel specifications, including part orientation and tape sizes, please refer to our Tape and Reel Packaging Specifications Brochure, BRD8011/D.

†Note: Please contact your ON Semiconductor sales representative for availability in tube.

# NB3H63143G

## PACKAGE DIMENSIONS

QFN16 3x3, 0.5P  
CASE 485AE  
ISSUE B

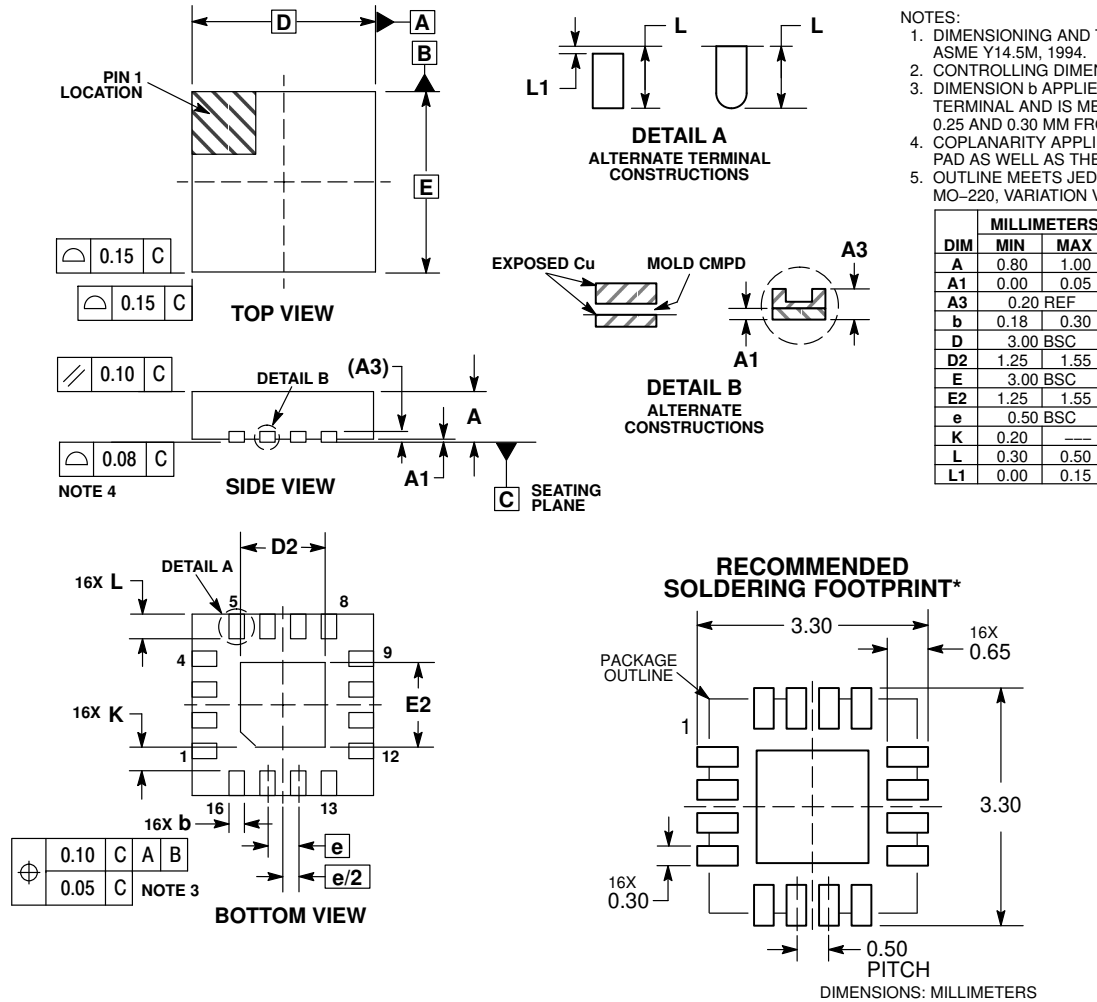

- NOTES:
1. DIMENSIONING AND TOLERANCING PER ASME Y14.5M, 1994.
  2. CONTROLLING DIMENSION: MILLIMETERS.
  3. DIMENSION b APPLIES TO PLATED TERMINAL AND IS MEASURED BETWEEN 0.25 AND 0.30 MM FROM TERMINAL.
  4. COPLANARITY APPLIES TO THE EXPOSED PAD AS WELL AS THE TERMINALS.
  5. OUTLINE MEETS JEDEC DIMENSIONS PER MO-220, VARIATION VEED-6.

\*For additional information on our Pb-Free strategy and soldering details, please download the ON Semiconductor Soldering and Mounting Techniques Reference Manual, SOLDERRM/D.

ON Semiconductor and the are registered trademarks of Semiconductor Components Industries, LLC (SCILLC) or its subsidiaries in the United States and/or other countries. SCILLC owns the rights to a number of patents, trademarks, copyrights, trade secrets, and other intellectual property. A listing of SCILLC's product/patent coverage may be accessed at [www.onsemi.com/site/pdf/Patent-Marking.pdf](http://www.onsemi.com/site/pdf/Patent-Marking.pdf). SCILLC reserves the right to make changes without further notice to any products herein. SCILLC makes no warranty, representation or guarantee regarding the suitability of its products for any particular purpose, nor does SCILLC assume any liability arising out of the application or use of any product or circuit, and specifically disclaims any and all liability, including without limitation special, consequential or incidental damages. "Typical" parameters which may be provided in SCILLC data sheets and/or specifications can and do vary in different applications and actual performance may vary over time. All operating parameters, including "Typicals" must be validated for each customer application by customer's technical experts. SCILLC does not convey any license under its patent rights nor the rights of others. SCILLC products are not designed, intended, or authorized for use as components in systems intended for surgical implant into the body, or other applications intended to support or sustain life, or for any other application in which the failure of the SCILLC product could create a situation where personal injury or death may occur. Should Buyer purchase or use SCILLC products for any such unintended or unauthorized application, Buyer shall indemnify and hold SCILLC and its officers, employees, subsidiaries, affiliates, and distributors harmless against all claims, costs, damages, and expenses, and reasonable attorney fees arising out of, directly or indirectly, any claim of personal injury or death associated with such unintended or unauthorized use, even if such claim alleges that SCILLC was negligent regarding the design or manufacture of the part. SCILLC is an Equal Opportunity/Affirmative Action Employer. This literature is subject to all applicable copyright laws and is not for resale in any manner.

### PUBLICATION ORDERING INFORMATION

**LITERATURE FULFILLMENT:**  
Literature Distribution Center for ON Semiconductor  
19521 E. 32nd Pkwy, Aurora, Colorado 80011 USA  
Phone: 303-675-2175 or 800-344-3860 Toll Free USA/Canada  
Fax: 303-675-2176 or 800-344-3867 Toll Free USA/Canada  
Email: [orderlit@onsemi.com](mailto:orderlit@onsemi.com)

**N. American Technical Support:** 800-282-9855 Toll Free  
USA/Canada  
**Europe, Middle East and Africa Technical Support:**  
Phone: 421 33 790 2910  
**Japan Customer Focus Center**  
Phone: 81-3-5817-1050

**ON Semiconductor Website:** [www.onsemi.com](http://www.onsemi.com)  
**Order Literature:** <http://www.onsemi.com/orderlit>  
For additional information, please contact your local Sales Representative