



Chipsmall Limited consists of a professional team with an average of over 10 year of expertise in the distribution of electronic components. Based in Hongkong, we have already established firm and mutual-benefit business relationships with customers from,Europe,America and south Asia,supplying obsolete and hard-to-find components to meet their specific needs.

With the principle of "Quality Parts,Customers Priority,Honest Operation,and Considerate Service",our business mainly focus on the distribution of electronic components. Line cards we deal with include Microchip,ALPS,ROHM,Xilinx,Pulse,ON,Everlight and Freescale. Main products comprise IC,Modules,Potentiometer,IC Socket,Relay,Connector.Our parts cover such applications as commercial,industrial, and automotives areas.

We are looking forward to setting up business relationship with you and hope to provide you with the best service and solution. Let us make a better world for our industry!



## Contact us

Tel: +86-755-8981 8866 Fax: +86-755-8427 6832

Email & Skype: info@chipsmall.com Web: www.chipsmall.com

Address: A1208, Overseas Decoration Building, #122 Zhenhua RD., Futian, Shenzhen, China



# NB3N1200KMNGEVB, NB3W1200LMNGEVB



ON Semiconductor®

<http://onsemi.com>

## NB3N1200K/NB3W1200L Evaluation Board User's Manual

### EVAL BOARD USER'S MANUAL

#### Introduction

The NB3N1200KMNGEVB and the NB3W1200LMNGEVB evaluation boards were developed with a common PCB layout design to accommodate the NB3N1200K (standard HCSL outputs) and the NB3W1200L (HCSL Push-Pull outputs) devices. Each board comes fully assembled and tested and is ready to evaluate in the lab. This evaluation board was designed to provide a flexible and convenient platform to quickly evaluate, characterize and verify the operation of the NB3N1200K or NB3W1200L devices. To minimize the board size, six differential outputs are accessed with SMA connectors. The other six differential outputs are loaded, terminated and can be monitored with a high impedance probe as explained later in the manual.

The NB3N1200K Evaluation Board schematic is the same as the NB3W1200L schematic except the “1200L” has some components depopulated (DNI) per the “1200L” BOM.

- The NB3W1200LMNGEVB does not have RP resistors installed on its differential Push-Pull outputs.
- The NB3W1200LMNGEVB does not have FB\_OUT/FB\_OUT# resistors installed.
- The NB3W1200LMNGEVB does not have RREF resistor R107 installed.

This manual should be used in conjunction with the device datasheet which contains full technical details on the device specifications and operation.

This evaluation board manual contains:

- Information on the NB3N1200K/NB3W1200L Evaluation Board
- Assembly Instructions
- Test and Measurement Setup Procedures
- Board Schematic and Bill of Materials

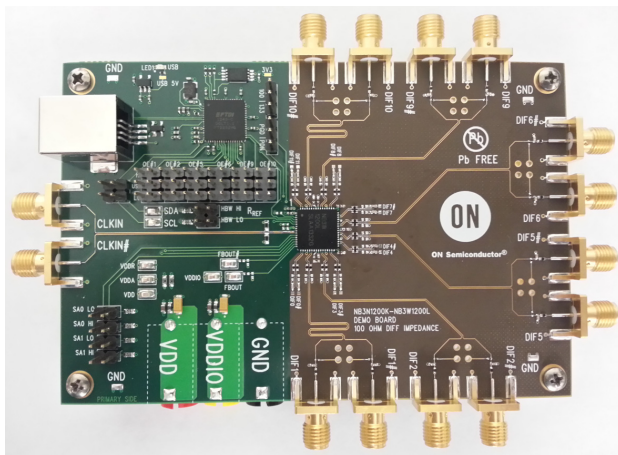

Top View

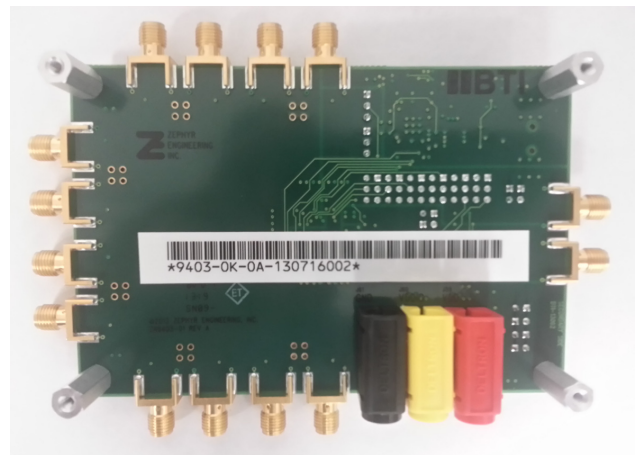

Bottom View

Figure 1. NB3N1200KMNGEVB and NB3W1200LMNGEVB Evaluation Board

# NB3N1200KMNGEVB, NB3W1200LMNGEVB

## QUICK START LAB SET-UP USER'S GUIDE

### Pre-Power-Up

1. The NB3N1200K and NB3W1200L have positive power supply pins VDD and VDDIO. Connect power supply cables to VDD, VDDIO and GND banana jacks; (do not turn power on, yet)
2. Connect a signal generator to the SMA connectors for the CLK\_IN & CLK\_IN# inputs.
3. 50-ohm termination resistors are installed for a signal generator on the board. Set appropriate input signal levels; (HCSL input,  $V_{IL} = 0\text{ V}$ ,  $V_{IH} = 700\text{ mV}$ , Frequency 100 or 133.33 MHz)
4. Ensure the PWRGD/PWRDN# pin is in the Low state before power up (PWRDN#). There is a jumper on pin 6 to easily select between High and Low. See Figure 8.
5. The 100M\_133M# and HBW\_BYPASS\_LBW pins need to be hardware selected with jumpers. See Figures 4 and 7.
6. To monitor the DIF\_n/DIF\_n# outputs, connect the DIF\_n/DIF\_n# outputs to the appropriate oscilloscope.

Table 1. POWER SUPPLY CONNECTIONS

Device Pin Power Supply Connector	Power Supply
VDD	3.3 V
VDDIO	1.05 V to 3.3 V
GND	0 V

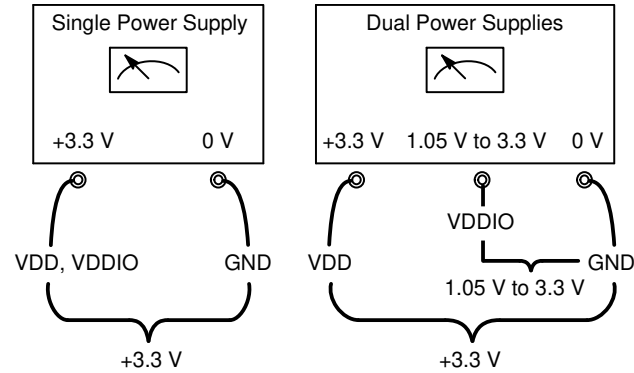

Figure 2. Power Supply Connections

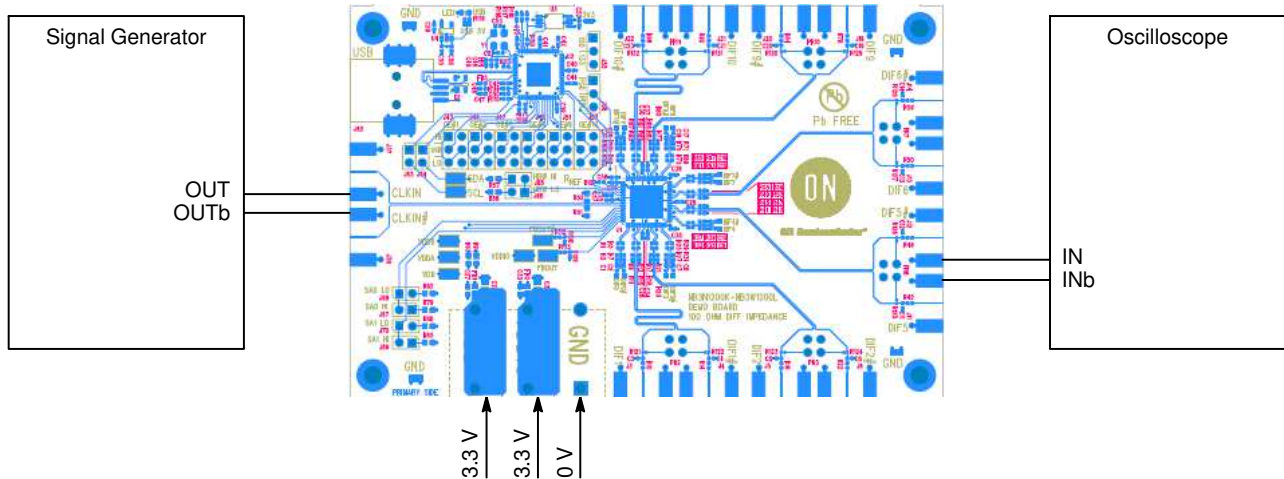

Figure 3. Typical Lab Test Set-Up

### Power -Up Sequence

1. Turn on power supply, 3.3 V (VDD & VDDIO).
2. Move PWRGD/PWRDN# jumper from Low to logic High, PWRGD position.
3. Turn on the Differential Clock Signal for the CLK\_IN inputs. The differential Clock signal for the CLK\_IN inputs can be ON or active before or after PWRGD is set HIGH.
4. Monitor DIF\_n/DIF\_n# outputs on oscilloscope.

### Optional

#### Graphical User Interface (see page 7)

There is a stand-alone Graphical User Interface software package and user's manual that will interface with the DUT via the USB connector.

1. Connect the USB port on the evaluation board to a USB port on the PC via cable.
2. See the stand-alone GUI instructions document.
3. Allow Windows to install the necessary drivers for the eval board USB interface hardware.
4. Start the GUI program.

# NB3N1200KMNGEVB, NB3W1200LMNGEVB

## Power Supplies

Each VDD, VDDIO and GND power supply has a separate side-launch banana jack located on bottom side.

This board is capable of measuring device IDD & IDDIO separately.

Board Layer #2 = SMA Ground = Device GND = 0 V.

GND Banana Jack = negative power supply for DUTGND and SMAGND.

**Exposed Pad (EP):** The exposed pad footprint on the board is soldered to the exposed pad of the QFN-64 package, and is electrically connected to GND power supply.

Board Layer #3 = VDD and VDDIO Power Supplies

VDD = positive power supply for core and inputs; VDD/VDDA/VDDR (pins #1, 8, 24, 40, 57)

VDDIO = positive power supply for outputs; VDDIO (pins #25, 32, 49, 56)

VDD & VDDIO have the power supply filtering per datasheet by the banana jacks.

All VDD/VDDA/VDDR/VDDIO device pins have a 0.1  $\mu$ F bypass capacitor installed on top side next to package pins.

## Control Pins

Each control pin can be managed manually with a H/L jumper header; H = VDD, L = GND.

*Tri-Level Input Pins - HBW\_BYPASS\_LBW#, SA0 and SA1*

The three tri-level input pins, HBW\_BYPASS\_LBW#, SA0 and SA1, have selectable (with jumper) 4.7 k-ohm pull-up to VDD and 4.7 k-ohm pull-down to GND resistors; No jumper defaults to open/float.

- For a HIGH Level – Put Jumper to High
- For a LOW Level – Put Jumper to Low
- For a MID Level – Put Jumper to both High and Low; this will Enable both Pull-up and Pull-down Resistors

*HBW\_BYPASS\_LBW#*

At J65 and J66 headers, there is a 4.7 k $\Omega$  pull-up to VDD and a 4.7 k $\Omega$  pull-down resistor to GND for manual control. See Figure 4.

*SA0 & SA1*

At J67 and J69 headers, there are 4.7 k $\Omega$  pull-ups to VDD and at J68 and J70, there are 4.7 k $\Omega$  pull-down resistors to GND for manual control. See Figure 5.

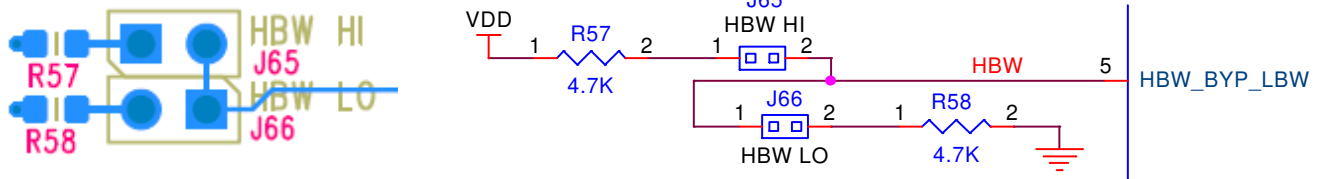

Figure 4. HBW\_BYPASS\_LBW# Schematic/PCB Configuration

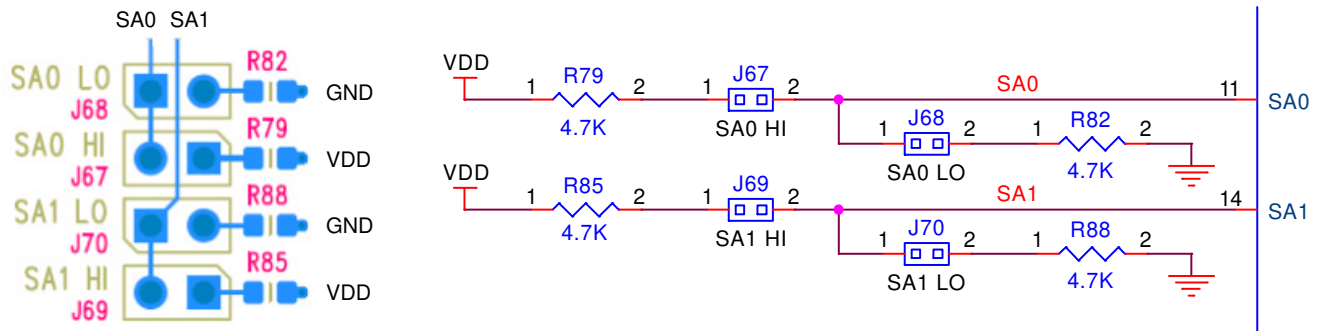

Figure 5. SA0 & SA1 Schematic/PCB Configuration

# NB3N1200KMNGEVB, NB3W1200LMNGEVB

## Control Pins (Continued)

### OE\_n# Pins (Output Enable/Disable Function)

Six of the twelve differential outputs that have metal traces going to SMA connectors have OE\_n# pins on the left side of the board that can be controlled manually using the convenient High/Low OE\_n# jumpers. See Figure 6.

All twelve of the OE\_n#s can be controlled individually/automatically by using the software GUI. GUI control is accomplished via the USB when the OE\_n# jumper is installed on the middle header position. See Figure 6.

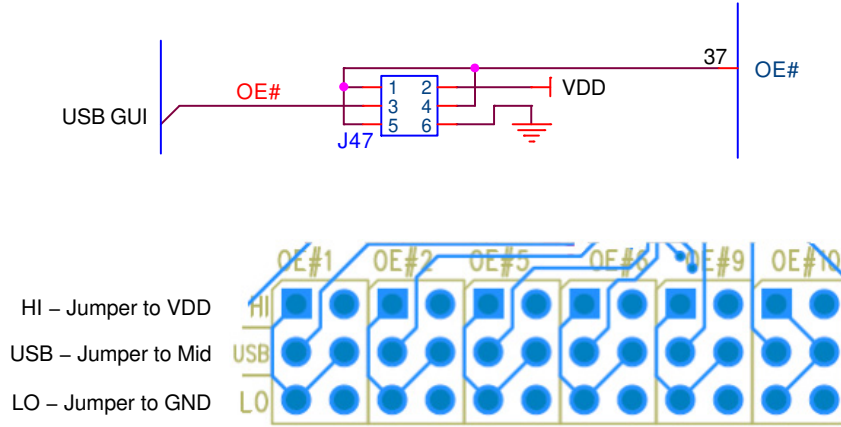

Figure 6. OE\_n# Pins Schematic/PCB Configuration

### 100M\_133M# - Frequency Selection (J55)

The 100M\_133M# frequency selection pin can be controlled manually with the High/Low header jumper J55, H = 100 MHz, L = 133 MHz.

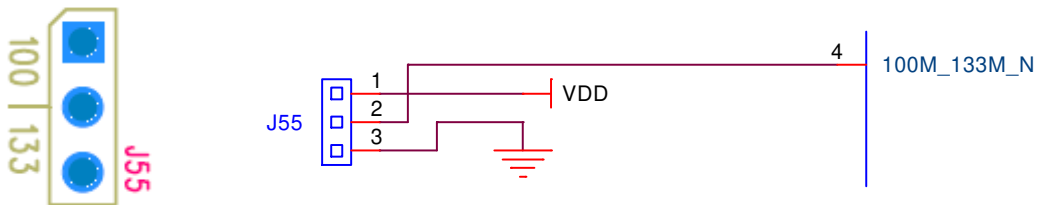

Figure 7. 100M\_133M# Pin Schematic/PCB Configuration

### PWRGD/PWRDN# (J56)

The PWRGD/PWRDN# pin can be controlled manually with the High/Low header jumper J56; H = PWRGD, L = PWRDN#.

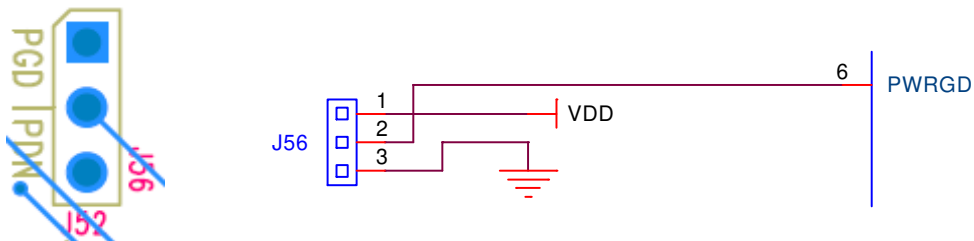

Figure 8. PWRGD/PWRDN# Pin Schematic/PCB Configuration

# NB3N1200KMNGEVB, NB3W1200LMNGEVB

## Differential Clock Inputs and Outputs

### CLK\_IN & CLK\_IN# - Differential Clock Inputs

The differential Clock input traces, CLK\_IN/CLK\_IN#, are equal length routed straight from the SMA connectors on the left side directly to the DUT; there are no vias on metal traces.

CLK\_IN & CLK\_IN# have resistor pads (R51 & R52) to GND to terminate a signal generator, if used. 50-ohm resistors are installed. **Remove these resistors** if CLK\_IN & CLK\_IN# are driven by another IC device.

### DIF\_n and DIF\_n# - Differential Outputs

NB3N1200KMNGEVB and NB3W1200LMNGEVB were designed with a flexible PCB layout configuration to measure the differential HCSL (1200K) or Push-Pull (1200L) outputs with a 50-ohm scope head or high-impedance FET probe. (See Output Layout in Figures 8 and 9)

Six of the twelve differential outputs are designed to have equal length metal traces from the device pins to the SMA connectors.

The other six differential outputs have shortened metal traces, do not have SMA connectors and can be observed with a high-impedance probe on the metal pads provided.

Each DIF\_n/DIF\_n# output has a provision for C<sub>Load</sub>; **2 pF capacitors are installed on all outputs.**

Rs & Rp pads are located close to the DUT. Rs = 33-Ω is installed for both the NB3N1200K and NB3W1200L.

### NB3N1200K (HCSL Outputs)

RP is not installed on the six output pair with long metal traces to SMA connectors; Use 50-Ω to GND of the oscilloscope head for RP.

Rp is installed (50-Ω to GND) on the short metal traces without SMA connectors and will use Hi-Z probes.

### NB3W1200L (Push-Pull Outputs)

Rp is not installed

**Table 2. NB3N1200KMNGEVB AND NB3W1200LMNGEVB OUTPUT LOAD AND TERMINATION VS. OSCILLOSCOPE MEASUREMENT**

Device	Output Traces	Rs	Rp	C <sub>Load</sub>	Scope
1200K	Long	33-Ω	Open (DNI)	2 pF	50-Ω
1200K	Short	33-Ω	50-Ω	2 pF	Hi-Z
1200L	Long or Short	33-Ω	Open (DNI)	2 pF	Hi-Z

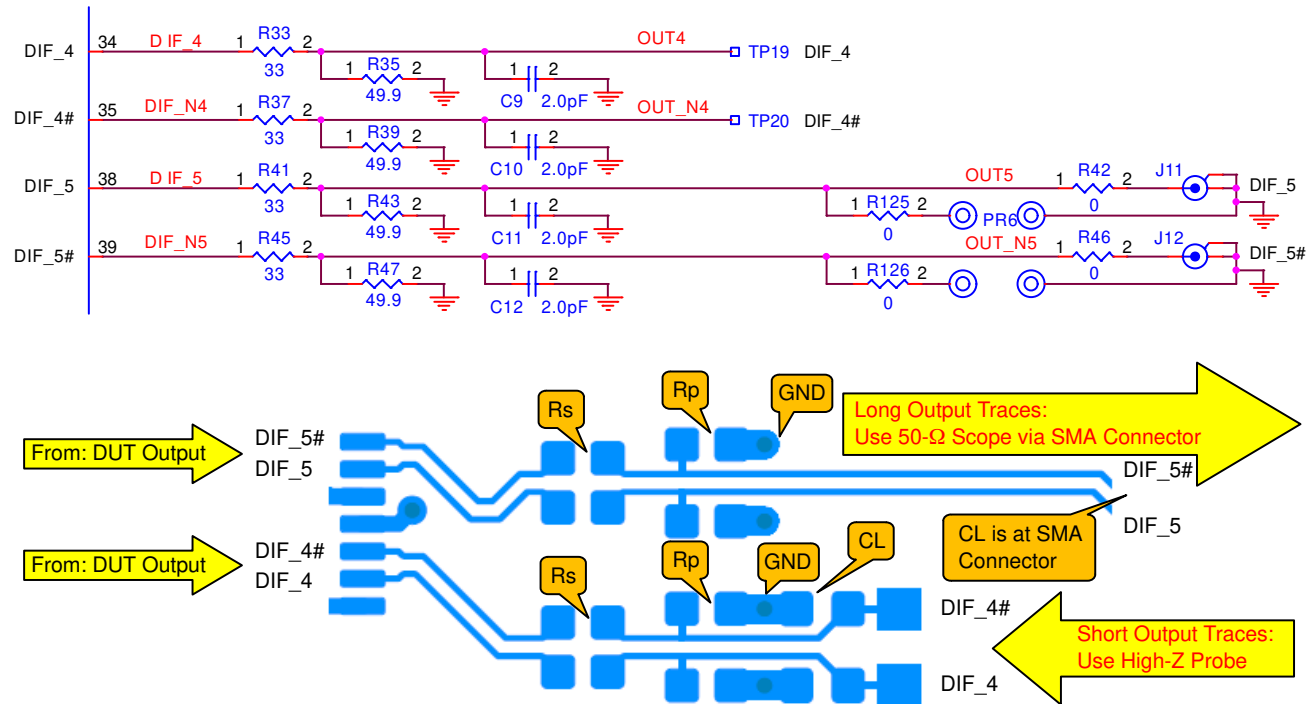

**Figure 9. Differential Outputs Schematic/PCB Configuration: Long vs. Short Metal Traces**

# NB3N1200KMNGEVB, NB3W1200LMNGEVB

## HCSL Output Measurement

HCSL outputs are typically terminated with 50-Ω to ground. Measuring HCSL outputs can be easily accomplished by:

### NB3N1200K (HCSL Outputs) – 50-Ω Oscilloscope Head

With  $R_P$  removed from board, connect the HCSL outputs through the SMA connectors to the 50-Ω internal impedance of the oscilloscope sampling head.

### NB3N1200K (HCSL Outputs) – Use Hi-Z Probe

With  $R_P$  installed, use a high-impedance probe on the output's metal trace. Holes for headers to connect to Hi-Z probes are available, but the header pins are not installed.

- Single-ended Hi-Z probes or,
- Differential Hi-Z probe; (see layout below)

### NB3W1200L (Push-Pull Outputs) – Use Hi-Z Probe

$R_P$  is not installed

- A 0-Ω series resistor is installed between the end of the transmission line and the SMA connector. This resistor can be removed, if needed, to eliminate any SMA impedance/stub when using Hi-Z probes.
- As a feature, an optional component can be installed on each output, ie. additional capacitance loading etc.

The following figures describe the boards' output features:

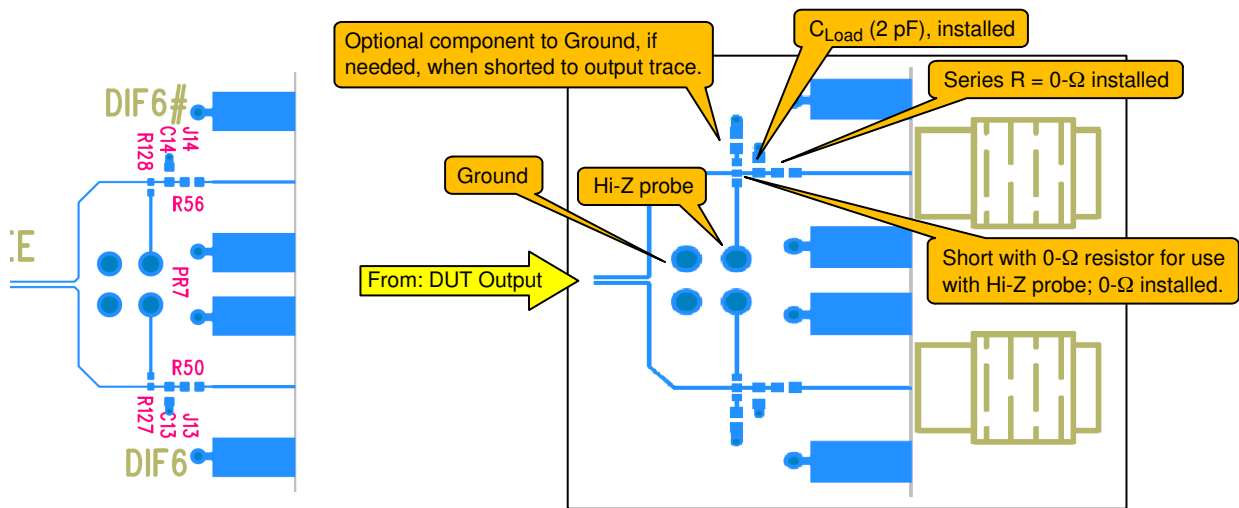

Figure 10. Differential Outputs Schematic/PCB Configuration: Use Hi-Z Probe Scope for NB3W1200L

## Misc. Pins

### FB\_OUT & FB\_OUT# – External Termination of Feedback Pins

FB\_OUT & FB\_OUT# have convenient “test point anvils” to monitor these pins with Hi-Z probe.

#### NB3N1200K (HCSL):

Since the FB\_OUT & FB\_OUT# pins do not drive transmission lines (no SMAs), the board layout has these pins loaded/terminated at the DUT per datasheet; 83-Ω to GND is installed for the 100-Ω board.

#### NB3W1200L (Push-Pull):

FB\_OUT & FB\_OUT# resistors are not installed.

## IREF Pin

### NB3N1200K (HCSL):

The  $R_{REF}$  resistor (R107) to GND for the HCSL output part device.

$R_{REF} = 475\text{-}\Omega$  is installed for the 100-Ω board.

### NB3W1200L (Push-Pull)

$R_{REF}$  is not installed for the NB3W1200L device.

# NB3N1200KMNGEVB, NB3W1200LMNGEVB

## Graphical User Interface (GUI)

### USB & I<sup>2</sup>C/SMBus Interface

The NB3N1200K EVB has an on-board I<sup>2</sup>C/SMBus interface circuitry located in the upper left section of the board.

This circuitry will interface with the software program and the device via the SDA and SCL input pins, and can control all twelve of the OE\_n# pins, PLL Mode and Frequency Select directly from the GUI.

### SCL & SDA

The SMBus Clock (SCL) and Data (SDA) pins are exercised through the on-board I<sup>2</sup>C interface.

In order to enable the I<sup>2</sup>C control of the DUT, **header jumpers J63 & J64 must be shorted.**

The I<sup>2</sup>C/SMBus interface circuitry is powered separately from the USB type-B connection and is isolated from device VDD and VDDIO.

The SDA and SCL pins can also be externally accessed by an off-board programmer, allowing other SMBus emulators to be used to program the DUT. If used, remove both jumpers J63 & J64. “Test-point anvils” TP5 & TP6 are available for external control of the device with the use with mini-grabber cables.

## BOARD FEATURES

### Single Board Design/Layout for NB3N1200K or NB3W1200L:

- The single board design and layout accommodates the electrical characterization of either the NB3N1200K (standard HCSL outputs) or the NB3W1200L (HCSL Push-Pull outputs).
- Incorporates on-board I<sup>2</sup>C/SMBus interface circuitry powered from a USB connection, minimizing cabling.
- Convenient and compact board layout.
- 3.3 V power supply device operation.
- Differential inputs/outputs signals are accessed via SMA connectors or high impedance probes.

### Other Board Features

There are no vias on the high-speed differential I/O metal traces so as to eliminate via impedance and stub affects.

Board stand-offs are installed.

### Board Layout

The NB3N1200K QFN-64 Evaluation Board provides a high bandwidth, 50-Ω controlled trace impedance

environment (100-Ω line-to-line differential) and is implemented in four layers.

- All layers are constructed with FR4 dielectric material.
- The first layer is the primary signal layer, including all of the differential inputs and outputs.
- The second layer is the ground plane. It is dedicated for the DUT ground/SMA ground plane.
- The third layer is dedicated as the power plane. A portion of this 3<sup>rd</sup> layer is designated for the device VDD and VDDIO power planes.
- The fourth layer contains control lines, power supply banana jacks and device power pin bypass capacitors.

### Layer Stack

- L1 (Top) Signal
- L2 Device Ground and SMA Ground
- L3 VDD, VDDIO (Separate Device Power Supplies)
- L4 (Bottom), Power Supply By-pass Capacitors, Control Pin Traces and Banana Jacks

## 4-LAYER STACK-UP

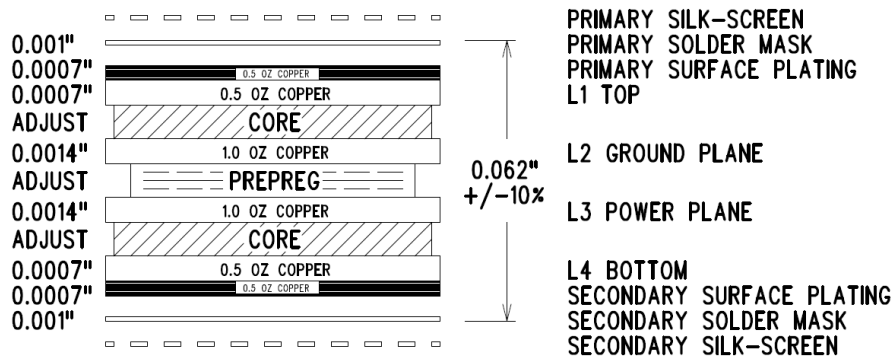

Figure 11. NB3N1200KMNGEVB and NB3W1200LMNGEVB Evaluation Board Layer Stack-Up



NB3N1200KMNGEVB, NB3W1200LMNGEVB

NB3N1200K/NB3W1200L EVALUATION BOARD SCHEMATIC

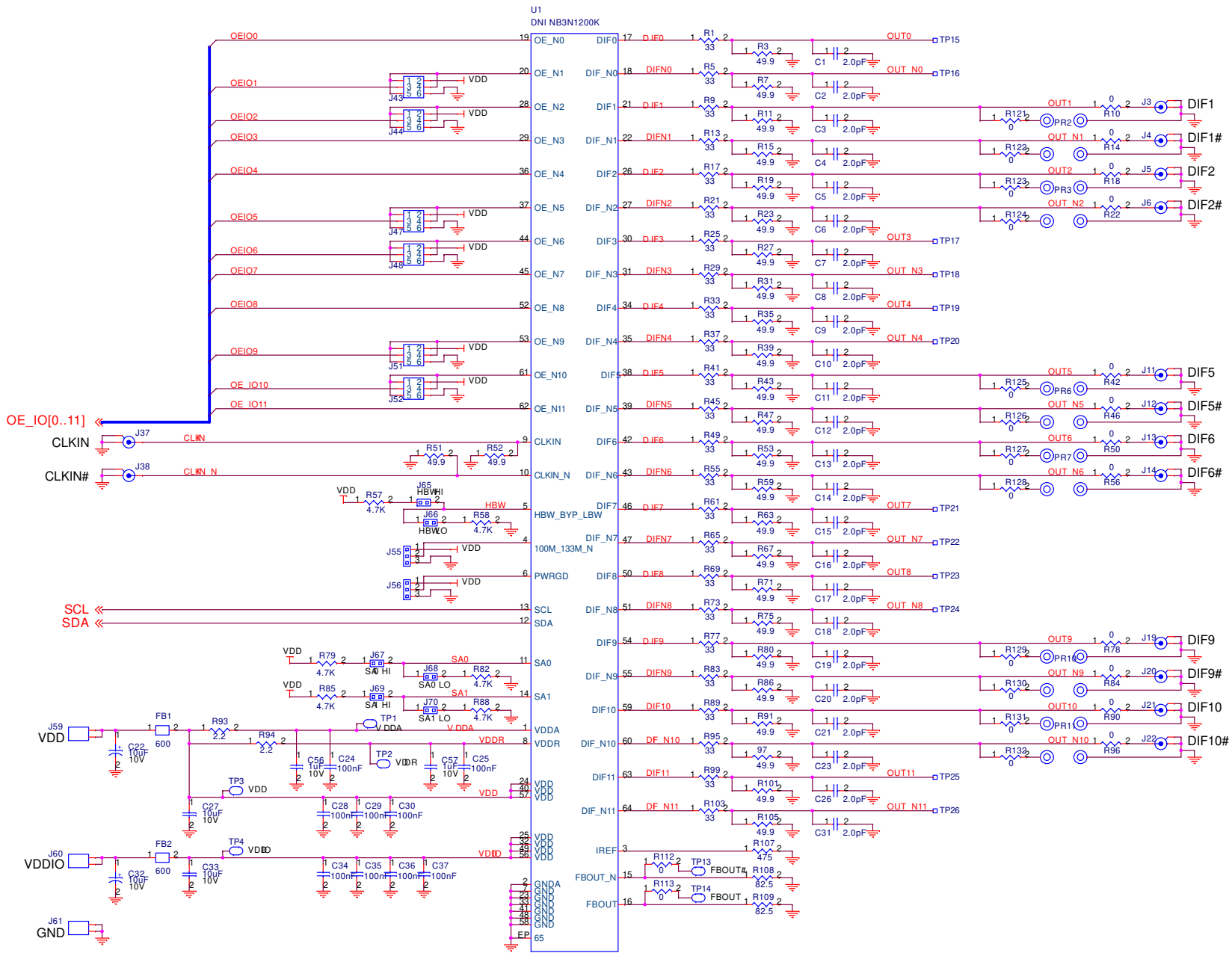

Figure 12. NB3N1200KMNGEVB & NB3W1200LMNGEVB Board Schematic

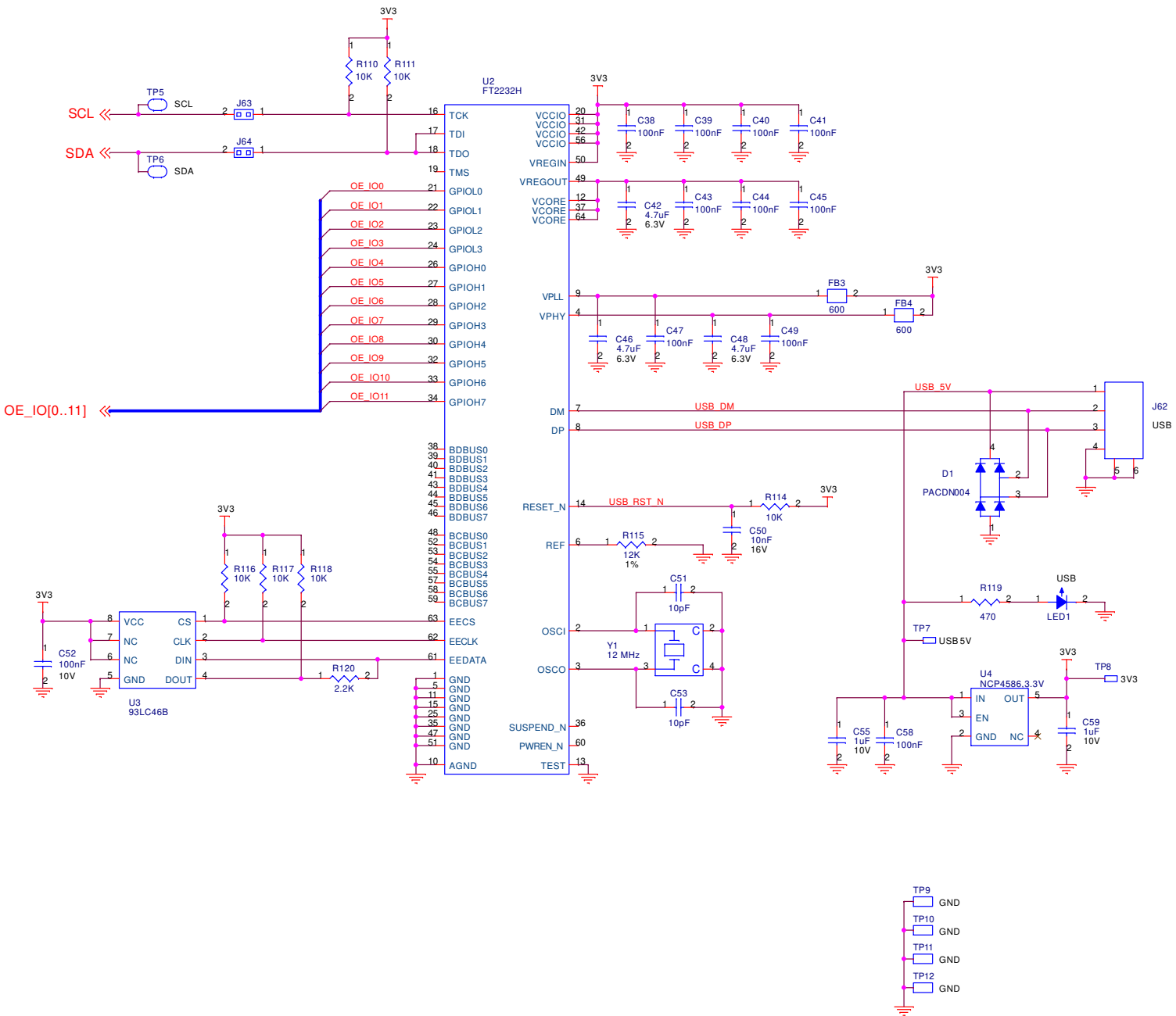

Figure 13. USB Circuitry Schematic

# NB3N1200KMNGEVB, NB3W1200LMNGEVB

**Table 3. BILL OF MATERIALS FOR THE NB3N1200KMNGEVB EVALUATION BOARD**

Designator	Qty.	Description	Value	Tolerance	Footprint	Manufacturer	Manufacturer Part Number	Substitution Allowed	Lead Free
B1	1	PC Board, Demo Board	-	-	-	-	-	-	Yes
C1-C21, C23, C26, C31	24	Capacitor	2.0 pF	12%	0402	TDK	C1005C0G1H020C	Yes	Yes
C22, C32	2	Capacitor	10 $\mu$ F	10%	1206	Vishay	TR3A106K010C2000	Yes	Yes
C24, C25, C2-C30, C34-C41, C43-C45, C47, C49, C52, C58	20	Capacitor	100 nF	10%	0402	AVX	0402ZD104KAT2A	Yes	Yes
C27, C33	2	Capacitor	10 $\mu$ F	20%	0603	TDK	C1608X5R1A106M	Yes	Yes
C42, C46, C48	3	Capacitor	4.7 $\mu$ F	20%	0402	TDK	C1005X5R0J475M	Yes	Yes
C50	1	Capacitor	10 nF	10%	0402	AVX	0402YC103KAT2A	Yes	Yes
C51, C53	2	Capacitor	10 pF	5%	0402	Murata	GRM1555C1H100JZ01D	Yes	Yes
C55-C57, C59	4	Capacitor	1 $\mu$ F	20%	0402	Murata	GRM155R61A105ME15D	Yes	Yes
D1	1	ESD Suppressor 4 CHANNEL PROTECTION	PACDN004	-	SOT-143	ON Semiconductor	PACDN004SR	No	Yes
FB1, FB2	2	EMI Filter Bead	600 $\Omega$	-	0603	Murata	BLM18KG601SN1D	Yes	Yes
FB3, FB4	2	EMI Filter Bead	600 $\Omega$	25%	0402	Murata	BLM15AG601SN1D	Yes	Yes
J3-J6, J11-J14, J19-J22, J37, J38	14	RF Connectors PC END MT JCK GLD .062"	-	-	SMA_END_LA UNCH_0.062"	Johnson Components	142-0701-801	Yes	Yes
J43, J44, J47, J48, J51, J52	6	Header	-	-	Header Thru-Hole 2 x 3	FCI	67996-206HLF	Yes	Yes
J56, J55	2	Header	Header 3-pin	-	3-pin Header, thru-hole 0.1	3M	961103-6404-AR	Yes	Yes
J59	1	Banana Jack, Thru-Hole, Red	-	-	CON2_571-050 0_DELTRON	Deltron	571-0500	Yes	Yes
J60	1	Banana Jack, Thru-Hole, Yellow	-	-	CON2_571-050 0_DELTRON	Deltron	571-0700	Yes	Yes
J61	1	Banana Jack, Thru-Hole, Black	-	-	CON2_571-050 0_DELTRON	Deltron	571-0100	Yes	Yes
J62	1	CONN USB TYPE B R/A HORIZ SMD	-	-	SMT USB Conn B	On Shore Technology	USB-B1SMHSW6	Yes	Yes
J63-J70	8	Header	Header 2-pin	-	2-pin Header, thru-hole 0.1	3M	961102-6404-AR	Yes	Yes
LED1	1	LED GREEN CLEAR 0603 SMD	LED, Green	-	0603 LED	Lite-On	LTST-C190KGKGT	Yes	Yes
M1-M8, M10, M12, M14, M17, M19, M21, M23-M25	17	CONN JUMPER SHORTING .100" GOLD	Shunt	-	2.54 x 5.97 (mm)	Sullins	QPC02SXGN-RC	Yes	Yes
M9, M11, M13, M15	4	STANDOFF 4-40 ALUMINUM 5/8"	Standoff, 4-40 1/4 x 5/8	-	-	Keystone	1808	Yes	Yes
M16, M18, M20, M22	4	Screw, 4-40 x 0.25, PHP	-	-	-	Building Fasteners	PMS 440 0025 PH	Yes	Yes
R1, R5, R9, R13, R17, R21, R25, R29, R33, R37, R41, R45, R49, R55, R61, R65, R69, R73, R77, R83, R89, R95, R99, R103	24	Resistor	33 $\Omega$	1%	0402	Panasonic	ERJ-2RKf33R0X	Yes	Yes

## NB3N1200KMNGEVB, NB3W1200LMNGEVB

**Table 3. BILL OF MATERIALS FOR THE NB3N1200KMNGEVB EVALUATION BOARD (continued)**

Designator	Qty.	Description	Value	Tolerance	Footprint	Manufacturer	Manufacturer Part Number	Substitution Allowed	Lead Free
R3, R7, R11, R15, R19, R23, R27, R31, R35, R39, R43, R47, R53, R59, R63, R67, R71, R75, R80, R86, R91, R97, R101, R105	24	Resistor	49.9 $\Omega$	1%	0402	Panasonic	ERJ-2RKF49R9X	Yes	Yes
R10, R14, R18, R22, R42, R46, R50, R56, R78, R84, R90, R96	12	Resistor	0 $\Omega$	Jumper	0402	Vishay	CRCW04020000Z0ED	Yes	Yes
R51, R52	2	Resistor	49.9 $\Omega$	1%	0603	Panasonic	ERJ-3EKF49R9V	Yes	Yes
R57, R58, R79, R82, R85, R88	6	Resistor	4.7 k $\Omega$	5%	0603	Panasonic	ERJ-3GEYJ472V	Yes	Yes
R94, R93	2	Resistor	2.2 $\Omega$	5%	0603	Panasonic	ERJ-3GEYJ2R2V	Yes	Yes
R107	1	Resistor	475 $\Omega$	1%	0402	Panasonic	ERJ-2RKF4750X	Yes	Yes
R108, R109	2	Resistor	82.5 $\Omega$	1%	0402	Panasonic	ERJ-2RKF82R5X	Yes	Yes
R110, R111, R114, R116-R118	6	Resistor	10 k $\Omega$	5%	0402	Panasonic	ERJ-2GEJ103X	Yes	Yes
R112, R113, R121-R132	14	Resistor	0 $\Omega$	Jumper	0201	Panasonic	ERJ-1GE0R00C	Yes	Yes
R115	1	Resistor	12 k $\Omega$	1%	0402	Panasonic	ERJ-2RKF1202X	Yes	Yes
R119	1	Resistor	470 $\Omega$	5%	0402	Panasonic	ERJ-2GEJ471X	Yes	Yes
R120	1	Resistor	2.2 k $\Omega$	5%	0402	Panasonic	ERJ-2GEJ222X	Yes	Yes
TP1, TP2, TP3, TP4, TP5, TP6, TP13, TP14	8	Test Point	Test Point, SMT	-	TP_5015_KEY STONE	Keystone	5015	Yes	Yes
U1	1	-	NB3N1200K	-	64-QFN 9 mm	ON Semiconductor	NB3W1200KMNG	No	Yes
U2	1	-	FT2232H	-	64-QFN	FTDI	FT2232HQ-REEL	No	Yes
U3	1	-	93LC46B	-	8-TSSOP	Microchip	93LC46BT-I/ST	No	Yes
U4	1	-	NCP4586, 3.3 V	-	SOT-23-5	ON Semiconductor	NCP4586DSN33T1G	No	Yes
Y1	1	-	12 MHz	-	2.5 x 3.2 (mm) SMT	Abracon Corp	ABM8G-12.000MHZ-4Y-T3	Yes	Yes

# NB3N1200KMNGEVB, NB3W1200LMNGEVB

**Table 4. BILL OF MATERIALS FOR THE NB3W1200LMNGEVB EVALUATION BOARD**

Designator	Qty.	Description	Value	Tolerance	Footprint	Manufacturer	Manufacturer Part Number	Substitution Allowed	Lead Free
B1	1	PC Board, Demo Board	-	-	-	-	-	-	Yes
C1-C21, C23, C26, C31	24	Capacitor	2.0 pF	12%	0402	TDK	C1005C0G1H020C	Yes	Yes
C22, C32	2	Capacitor	10 $\mu$ F	10%	1206	Vishay	TR3A106K010C2000	Yes	Yes
C24, C25, C28-C30, C34-C41, C43-C45, C47, C49, C52, C58	20	Capacitor	100 nF	10%	0402	AVX	0402ZD104KAT2A	Yes	Yes
C27, C33	2	Capacitor	10 $\mu$ F	20%	0603	TDK	C1608X5R1A106M	Yes	Yes
C42, C46, C48	3	Capacitor	4.7 $\mu$ F	20%	0402	TDK	C1005X5R0J475M	Yes	Yes
C50	1	Capacitor	10 nF	10%	0402	AVX	0402YC103KAT2A	Yes	Yes
C51, C53	2	Capacitor	10 pF	5%	0402	Murata	GRM1555C1H100JZ01D	Yes	Yes
C55-C57, C59	4	Capacitor	1 $\mu$ F	20%	0402	Murata	GRM155R61A105ME15D	Yes	Yes
D1	1	ESD Suppressor 4 CHANNEL PROTECTION	PACDN004	-	SOT-143	ON Semiconductor	PACDN004SR	No	Yes
FB1, FB2	2	EMI Filter Bead	600 $\Omega$	-	0603	Murata	BLM18KG601SN1D	Yes	Yes
FB3, FB4	2	EMI Filter Bead	600 $\Omega$	25%	0402	Murata	BLM15AG601SN1D	Yes	Yes
J3-J6, J11-J14, J19-J22, J37, J38	14	RF Connectors PC END MT JCK GLD .062"	-	-	SMA_END_LA UNCH_0.062"	Johnson Components	142-0701-801	Yes	Yes
J43, J44, J47, J48, J51, J52	6	Header	-	-	Header Thru-Hole 2 x 3	FCI	67996-206HLF	Yes	Yes
J56, J55	2	Header	Header 3-pin	-	3-pin Header, thru-hole 0.1	3M	961103-6404-AR	Yes	Yes
J59	1	Banana Jack, Thru-Hole, Red	-	-	CON2_571-050 0_DELTRON	Deltron	571-0500	Yes	Yes
J60	1	Banana Jack, Thru-Hole, Yellow	-	-	CON2_571-050 0_DELTRON	Deltron	571-0700	Yes	Yes
J61	1	Banana Jack, Thru-Hole, Black	-	-	CON2_571-050 0_DELTRON	Deltron	571-0100	Yes	Yes
J62	1	CONN USB TYPE B R/A HORIZ SMD	-	-	SMT USB Conn B	On Shore Technology	USB-B1SMHSW6	Yes	Yes
J63-J70	8	Header	Header 2-pin	-	2-pin Header, thru-hole 0.1	3M	961102-6404-AR	Yes	Yes
LED1	1	LED GREEN CLEAR 0603 SMD	LED, Green	-	0603 LED	Lite-On	LTST-C190KGKGT	Yes	Yes
M1-M8, M10, M12, M14, M17, M19, M21, M23-M25	17	CONN JUMPER SHORTING .100" GOLD	Shunt	-	2.54 x 5.97 (mm)	Sullins	QPC02SXGN-RC	Yes	Yes
M9, M11, M13, M15	4	STANDOFF 4-40 ALUMINUM 5/8"	Standoff, 4-40 1/4 x 5/8	-	-	Keystone	1808	Yes	Yes
M16, M18, M20, M22	4	Screw, 4-40 x 0.25, PHP	-	-	-	Building Fasteners	PMS 440 0025 PH	Yes	Yes
R1, R5, R9, R13, R17, R21, R25, R29, R33, R37, R41, R45, R49, R55, R61, R65, R69, R73, R77, R83, R89, R95, R99, R103	24	Resistor	33 $\Omega$	1%	0402	Panasonic	ERJ-2RKF33R0X	Yes	Yes

# NB3N1200KMNGEVB, NB3W1200LMNGEVB

**Table 4. BILL OF MATERIALS FOR THE NB3W1200LMNGEVB EVALUATION BOARD (continued)**

Designator	Qty.	Description	Value	Tolerance	Footprint	Manufacturer	Manufacturer Part Number	Substitution Allowed	Lead Free
R3, R7, R11, R15, R19, R23, R27, R31, R35, R39, R43, R47, R53, R59, R63, R67, R71, R75, R80, R86, R91, R97, R101, R105	0	DNI	-	-	0402	-	-	-	Yes
R10, R14, R18, R22, R42, R46, R50, R56, R78, R84, R90, R96	12	Resistor	0 Ω	Jumper	0402	Vishay	CRCW04020000Z0ED	Yes	Yes
R51, R52	2	Resistor	49.9 Ω	1%	0603	Panasonic	ERJ-3EKF49R9V	Yes	Yes
R57, R58, R79, R82, R85, R88	6	Resistor	4.7 kΩ	5%	0603	Panasonic	ERJ-3GEYJ472V	Yes	Yes
R93, R94	2	Resistor	2.2 Ω	5%	0603	Panasonic	ERJ-3GEYJ2R2V	Yes	Yes
R107	1	Resistor	475 Ω	1%	0402	Panasonic	ERJ-2RKF4750X	Yes	Yes
R108, R109	0	DNI	-	-	0402	-	-	-	Yes
R110, R111, R114, R116-R118	6	Resistor	10 kΩ	5%	0402	Panasonic	ERJ-2GEJ103X	Yes	Yes
R112, R113, R121-R132	14	Resistor	0 Ω	Jumper	0201	Panasonic	ERJ-1GE0R00C	Yes	Yes
R115	1	Resistor	12 kΩ	1%	0402	Panasonic	ERJ-2RKF1202X	Yes	Yes
R119	1	Resistor	470 Ω	5%	0402	Panasonic	ERJ-2GEJ471X	Yes	Yes
R120	1	Resistor	2.2 kΩ	5%	0402	Panasonic	ERJ-2GEJ222X	Yes	Yes
TP1-TP6, TP13, TP14	8	Test Point	Test Point, SMT	-	TP_5015_KEYSTONE	Keystone	5015	Yes	Yes
U1	1	-	NB3W1200L	-	64-QFN 9 mm	ON Semiconductor	NB3W1200LMNG	No	Yes
U2	1	-	FT2232H	-	64-QFN	FTDI	FT2232HQ-REEL	No	Yes
U3	1	-	93LC46B	-	8-TSSOP	Microchip	93LC46BT-I/ST	No	Yes
U4	1	-	NCP4586, 3.3 V	-	SOT-23-5	ON Semiconductor	NCP4586DSN33T1G	No	Yes
Y1	1	-	12 MHz	-	2.5 × 3.2 (mm) SMT	Abracon Corp	ABM8G-12.000MHZ-4Y-T3	Yes	Yes

**ON Semiconductor** and  are registered trademarks of Semiconductor Components Industries, LLC (SCILLC). SCILLC owns the rights to a number of patents, trademarks, copyrights, trade secrets, and other intellectual property. A listing of SCILLC's product/patent coverage may be accessed at [www.onsemi.com/site/pdf/Patent-Marking.pdf](http://www.onsemi.com/site/pdf/Patent-Marking.pdf). SCILLC reserves the right to make changes without further notice to any products herein. SCILLC makes no warranty, representation or guarantee regarding the suitability of its products for any particular purpose, nor does SCILLC assume any liability arising out of the application or use of any product or circuit, and specifically disclaims any and all liability, including without limitation special, consequential or incidental damages. "Typical" parameters which may be provided in SCILLC data sheets and/or specifications can and do vary in different applications and actual performance may vary over time. All operating parameters, including "Typicals" must be validated for each customer application by customer's technical experts. SCILLC does not convey any license under its patent rights nor the rights of others. SCILLC products are not designed, intended, or authorized for use as components in systems intended for surgical implant into the body, or other applications intended to support or sustain life, or for any other application in which the failure of the SCILLC product could create a situation where personal injury or death may occur. Should Buyer purchase or use SCILLC products for any such unintended or unauthorized application, Buyer shall indemnify and hold SCILLC and its officers, employees, subsidiaries, affiliates, and distributors harmless against all claims, costs, damages, and expenses, and reasonable attorney fees arising out of, directly or indirectly, any claim of personal injury or death associated with such unintended or unauthorized use, even if such claim alleges that SCILLC was negligent regarding the design or manufacture of the part. SCILLC is an Equal Opportunity/Affirmative Action Employer. This literature is subject to all applicable copyright laws and is not for resale in any manner.

## PUBLICATION ORDERING INFORMATION

### LITERATURE FULFILLMENT:

Literature Distribution Center for ON Semiconductor  
P.O. Box 5163, Denver, Colorado 80217 USA  
**Phone:** 303-675-2175 or 800-344-3860 Toll Free USA/Canada  
**Fax:** 303-675-2176 or 800-344-3867 Toll Free USA/Canada  
**Email:** [orderlit@onsemi.com](mailto:orderlit@onsemi.com)

**N. American Technical Support:** 800-282-9855 Toll Free  
USA/Canada  
**Europe, Middle East and Africa Technical Support:**  
Phone: 421 33 790 2910  
**Japan Customer Focus Center**  
Phone: 81-3-5817-1050

**ON Semiconductor Website:** [www.onsemi.com](http://www.onsemi.com)

**Order Literature:** <http://www.onsemi.com/orderlit>

For additional information, please contact your local Sales Representative